

HITACHI

Semi-Hermetic Horizontal Screw Compressor

For High Temperature Application
With R-22, R-134a & R407C Refrigerants

Models: 4005SC-Z

5005SC-Z

6005SC-Z

10001SC-Z

Service and Operation Information



AC Component Specialists, Inc.
899 South Prairie Lane
P.O. Box 500
Marshfield, Missouri 65706

Suggested Retail \$15.00

Phone: (417) 859-6067 Fax: (417) 859-2109

Contents

<u>Safety Precautions</u>	page 4
<u>General Product Features & Specifications</u>	page 5-12
1.0 Product Introduction	page 5
1.1 Product Features	page 5
1.2 Enhanced Product Features	page 5
2.0 Production Features	page 5
2.1 Screw Compressor vs. Reciprocating Compressor	page 6
2.2 HITACHI Screw Compressor Advantage	page 6
2.3 Construction	page 7
2.4 Refrigerant Flow	page 8
2.5 Oil Flow	page 8
2.6 Capacity Control System	page 8
Table - Solenoid Sequence of Operation Models; 4005SC-Z, 5005SC-Z and 6005SC-Z	page 9
Table - Solenoid Sequence of Operation Model: 10001SC-Z	page 10
Minimum Capacity for Starting	page 11
Load Up	page 11
Load Down	page 11
Load Constant	page 11
Location of Solenoid Valves	page 11
2.7 Details of Components	page 12
3.0 HITACHI Compressor Cores	page 12
<u>Operating Conditions</u>	page 13
Reverse Rotation	page 13
Power and Control Circuits	page 13
Suction and Discharge Pressure	page 13
Return Liquid Slugging	page 13
<u>Operational Safeties</u>	page 14-15
Electrical Applied Safeties (All Manual Reset)	page 14
Mechanical Safeties and Operational Requirements	page 15
<u>Protective Devices</u>	page 16
Motor Protector	page 16
Oil Heater (crankcase heater)	page 16
Continuous Capacity Control	page 16
Reverse Rotation	page 16
Discharge Temperature Protection	page 16
<u>Pilot Duty Electron Motor Protection Modules</u>	page 17
<u>2ACE Electronic Motor Protection</u>	page 18-19
Specifications	page 18
Fault Diagnostic Display Codes	page 19

<u>Electrical Phasing for Proper Compressor Rotation</u>	page 20
<u>Oil Management</u>	page 21
<u>Oil Specification and Maintenance</u>	page 22
<u>HITACHI Approved Oil</u>	page 23
<u>Oil Retrofit Installation Kit</u>	page 24
<u>Wiring Diagrams</u>	page 25-31
<u>Permissible Voltage Range</u>	page 32
<u>General Product Information Table</u>	page 33
<u>Standard Torque Values</u>	page 34
<u>Kits Available through ACCS</u>	page 35
<u>Service Parts List and View</u>	page 36-39
Models: 4005SC-Z, 5005SC-Z, and 6005SC-Z	page 36-37
Model: 10001SC-Z	page 38-39
<u>Warranty Information</u>	page 40
<u>Compressor Identification Information</u>	page 41
<u>Compressor Maintenance Information</u>	page 42
<u>Compressors Start-up Procedure</u>	page 43

NOTICE

SAFETY PRECAUTIONS

In performing any work on the compressor or the associated refrigeration equipment, proper safety procedures must ALWAYS be observed. Procedures include, but may not be limited to, the following:

- 1) Only qualified refrigeration mechanics familiar with the HITACHI compressor maintenance procedures should attempt any service to the HITACHI compressor.*
- 2) The compressor may be hot from operation and the oil contained therein will also be hot, allow the compressor and the oil to cool to room temperature before beginning any service to prevent burns.*
- 3) Remove and lockout all sources of power from the compressor to prevent accidental restart.*
- 4) Isolate the compressor from the refrigeration system.*
- 5) Recover the refrigerant from the compressor.*
- 6) Check to confirm that the pressure within the compressor is at no more than 2 or 3 psig above atmospheric pressure before any service is begun.*
- 7) Adherence to all national environmental requirements and local codes and ordinances is vital. It is not the intent of this bulletin to supercede any governing codes or safety practices while performing the service outlined herein.*

HITACHI - HORIZONTAL SCREW COMPRESSOR MODELS 4005SC-Z, 5005SC-Z, 6005SC-Z and 10001SC-Z GENERAL PRODUCT FEATURES & SPECIFICATIONS

1.0 Product Introduction

AC Component Specialists Service and Operations Information Guide describes general features and specifications of the HITACHI 4005SC-Z, 5005SC-Z, 6005SC-Z and 10001SC-Z screw compressor models. HITACHI has been manufacturing the rotary screw compressor design since the late sixties. Worldwide market introduction was in 1973. The HITACHI screw compressors has an overall failure rate for all shipments worldwide of less than zero point five percent (0.5%).

Since 1982 the compressor has been distributed in North America with shipments exceeding twenty thousand (20,000) units to date. The HITACHI screw compressor has provided excellent service with long lasting performance to a wide range of customers and applications.

1.1 Product Features

The HITACHI semi-hermetic screw compressor has been developed by HITACHI's own technology, including research and development activities, production engineering and system engineering. It is backed with quality HITACHI manufacturing experience with hermetic and semi-hermetic reciprocating compressors, centrifugal compressors and open screw compressors.

The years invested in research, development, and production has established HITACHI as the world leader in the HVAC/R industry in rotary screw compressor technology. Technological innovations such as the semi-hermetic two-pole motor in the large capacity range, an internal oil separator and the use of a combination of ball type and roller type bearings for axial and radial loads, assure a product designed to deliver reliable service to the owner.

1.2 Enhanced Product Features

In 2000 HITACHI introduced the "005" series model. This new model uses a common oil (Castrol SW220HT) for all three refrigerants (R-22, R-134a, and R-407C). Other changes and improvements are a newly designed longer life gasket material and terminal plate. The "005" series weighs less and produces less noise during operation than previous models.

2.0 Production Features

The HITACHI screw compressor is a positive displacement compressor allowing high compression ratios to be achieved.

Compression Principle

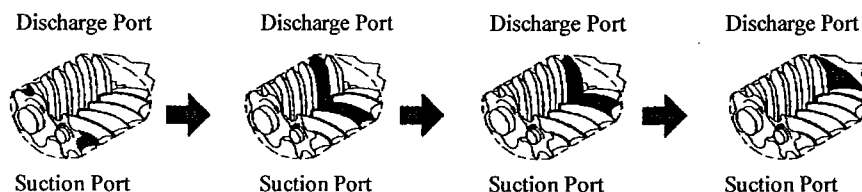

Figure 2-1
Principle of Screw Compressor

2.1 Screw Compressor vs. Reciprocating Compressor

(1) Fewer Moving Parts

The number of parts in the screw compressor is approximately one tenth the number of parts in reciprocating compressor. Screw compressors feature the simplicity of construction by eliminating such components as pistons, connecting rods, valve plates, oil pumps and mechanical linkages for capacity control, most commonly found in reciprocating compressors. The absence of these features in a screw compressor provides lower noise levels, minimized vibration, and higher reliability.

(2) Energy Savings

By infinitely modulating the capacity control, the screw compressor can offer a substantial energy savings to the owner. A control range of $\pm 2 \frac{1}{2}^{\circ}\text{F}$, typical of reciprocating compressors, causes the equipment to continually short cycle between stages resulting in a poor attempt to match the load.

(3) Resistance to Slugging

Screw compressors have greater resistance to liquid floodback than reciprocating compressors, due to the relative size and strength of the compression mechanism (rotors vs. connecting rods).

(4) Improved Lubrication System

Internal lubrication in the HITACHI screw compressor is supplied by the pressure difference between the discharge and suction sides instead of a mechanically pumped lubrication system found in reciprocating compressors. Rapid oil foaming does not occur in HITACHI screw compressors because the lubrication oil is stored in the high pressure side.

2.2 HITACHI Screw Compressor Advantage

HITACHI semi-hermetic screw compressors are provided with the following innovations:

(1) A pair of patented new profile screw rotors, developed by HITACHI's own technology, have improved the efficiency in the operation with a high compression ratio.

(2) A built-in oil separator, elimination of the oil pump, oil cooler and oil piping have increased reliability and durability in the compressors.

(3) The patented double casing construction of the HITACHI screw compressor, decreases the transmission of sound. This unique casing design makes the compressor one of the quietest in its class.

(4) The type and number of roller ball bearings used to position the screw rotors, and to support axial loads, extends the life of the compressor and increases its reliability.

(5) The use of highly reliable two-pole large capacity semi-hermetic motors, developed by HITACHI's own technology, has resulted in a highly-efficient and durable screw compressor.

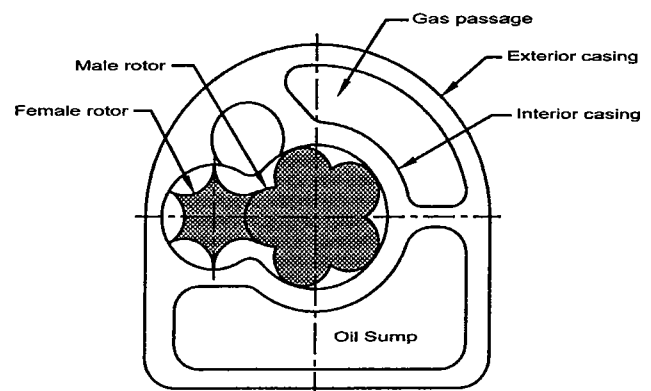

Figure 2-2
Double Casing Construction

2.3 Construction

HITACHI semi-hermetic screw compressors have three major compartments:

(1) Semi-hermetic Motor Compartment

The semi-hermetic motor compartment includes the motor rotor and stator, six terminal lugs for the electric power connections, internal thermistors inserted into the stator coils to protect the motor from over temperature, four terminal connectors for the thermistors, and a suction gas strainer. The motor rotor of the semi-hermetic motor is directly mounted on the suction end of the male screw rotor and drives it with a rotation of 2,880 rpm at 50 Hz or 3,470 rpm at 60 Hz at the rated voltage.

(2) Screw Compressor Compartment

The compressor compartment includes a pair of screw rotors, bearings and the components for the capacity control system.

(3) Oil Separator Compartment

The oil separator compartment includes a demister that serve as an oil separator and an oil sump reservoir with an oil strainer.

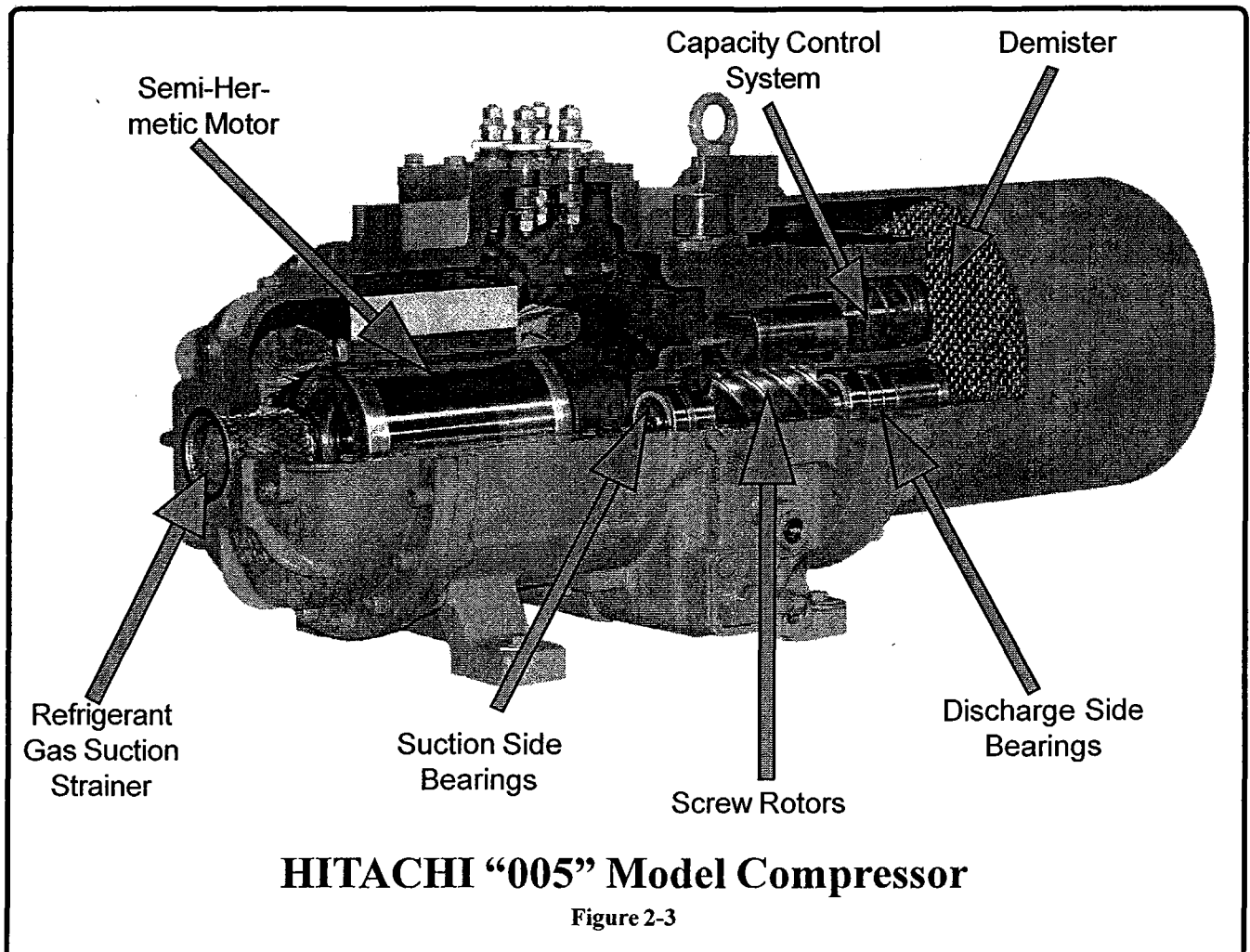

2.4 Refrigerant Flow

The suction gas enters the HITACHI screw compressor through the suction gas strainer, then through the motor compartment allowing the motor to be cooled. The refrigerant gas passes from the motor compartment into the compressor compartment. Here the gas is compressed by flowing from the suction side to the discharge side through a pair of screw rotors. The discharged refrigerant gas from the compressor compartment enters into the oil separator compartment. The oil is separated from the refrigerant gas as the mixture flows through the demister. The separated oil is stored in the oil separator, and the refrigerant gas is discharged from the discharge port.

2.5 Oil Flow

Oil passages from the oil reservoir are constructed internally in the compressor casing, aiding in the reduction of oil leakage. An oil strainer is inserted in the oil sump reservoir and is mounted with a removable flange that includes an oil drain valve.

Oil that is stored in the oil separator is fed through the oil strainer to the bearings and capacity control system. The oil lubricates the bearings, then enters into the suction area of the screw rotors. The oil, which is fed into the capacity control system, also flows back through the suction side of the screw rotors after it has been utilized as hydraulic power. Finally, the oil is discharged into the oil separator as a mixture of refrigerant and oil.

2.6 Capacity Control System

The HITACHI screw compressor has capacity control range for the 4005SC-Z from 33% to 100%, on the 5005SC-Z, 6005SC-Z and 10001SC-Z ranging from 25% to 100%. Control is provided by the movement of a slide valve located on the upper side of the screw rotors. Movement of the slide valve along the screw rotors controls the amount of refrigerant gas that is bypassed to the suction side. Connected to the slide valve is a piston that is located in the discharge casing. (See Fig. 2-4).

The piston moves in response to the volume of oil contained in the capacity control cylinder. Three solenoid valves, which are installed in the oil passages, are used in combination to provide accurate infinite capacity control.

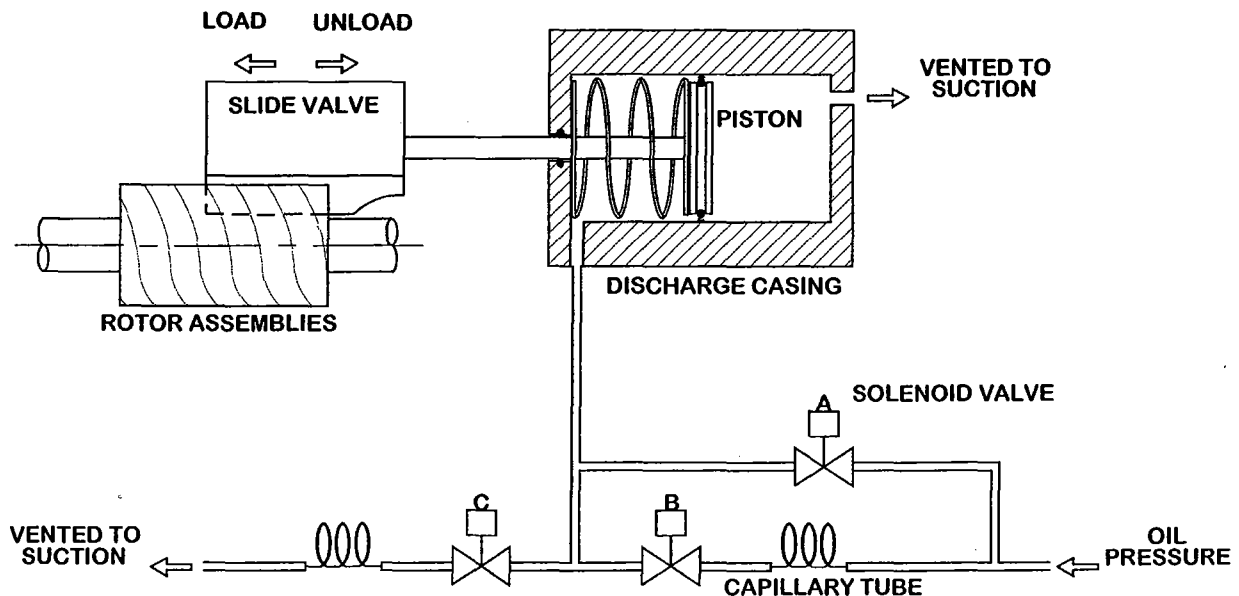

Figure 2-4: Capacity Control System

**HITACHI SCREW COMPRESSOR
MODELS 4005SC-Z, 5005SC-Z, and 6005SC-Z
INFINITE CAPACITY CONTROL SYSTEM**

Condition	Solenoid A	Solenoid B	Solenoid C
Start/Stop	ON	OFF	OFF
Loading up	OFF	OFF	ON
Unloading	OFF	ON	OFF
Load Constant	OFF	OFF	OFF

Table 1: Solenoid Sequence of Operation
For Model: 4005SC-Z, 5005SC-Z, and 6005SC-Z

**LOCATION OF SOLENOID VALVES FOR MODEL:
4005SC-Z, 5005SC-Z and 6005SC-Z**

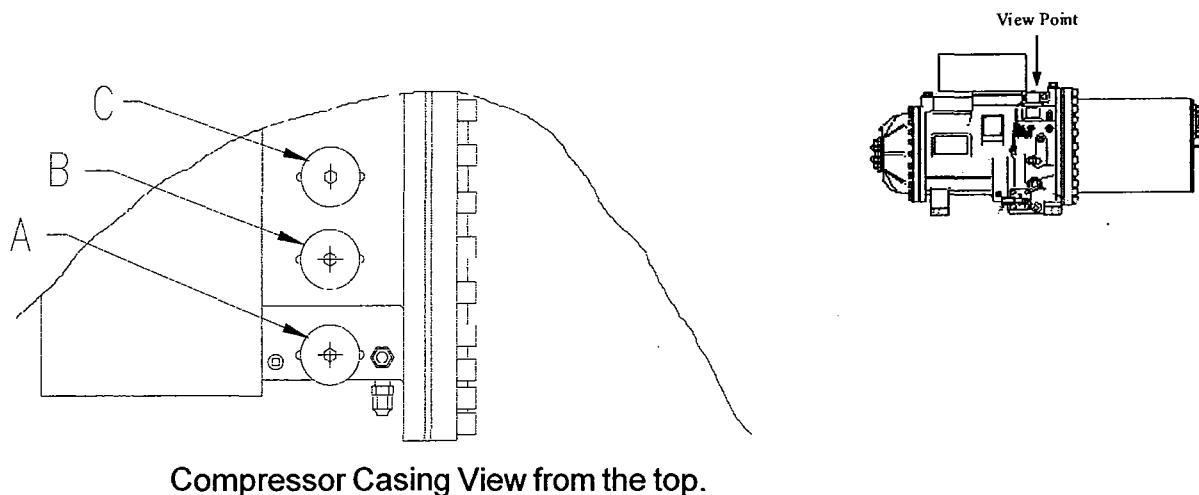

Figure 2.5

NOTE:

1. Minimum Load:
33% for 4005SC-Z
25% for 5005SC-Z and 6005SC-Z
2. A controller for the capacity control system is not included with the compressor.

HITACHI SCREW COMPRESSOR MODEL 10001SC-Z INFINITE CAPACITY CONTROL SYSTEM

Condition	Solenoid A	Solenoid B	Solenoid C
Start / Stop	ON	OFF	OFF
Loading up	OFF	ON	OFF
Unloading	OFF	OFF	ON
Load Constant	OFF	OFF	OFF

Table 2 Solenoid Sequence of Operation for Model 10001SC-Z

LOCATION OF SOLENOID VALVES FOR MODEL 10001SC-Z

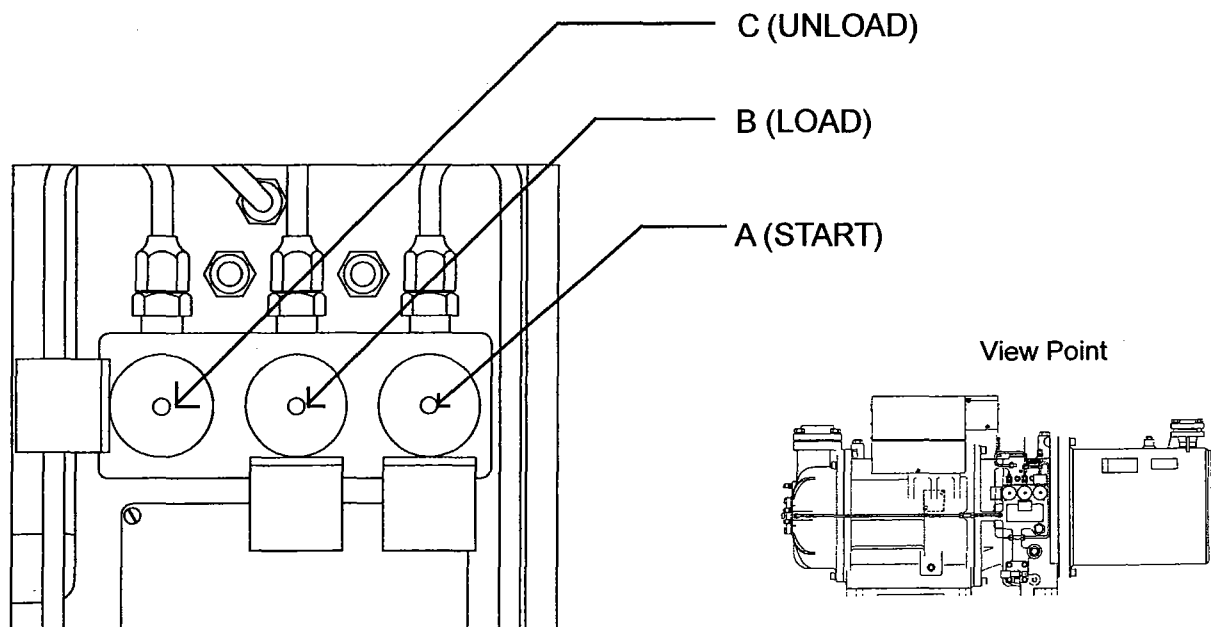

Compressor casing view from the side.

Figure 2-6

Note:

1. Minimum Load: 25% for 10001SC-Z
2. A controller for the infinite capacity control system is not included with the compressor.

Minimum Capacity for Starting
Models 4005SC-Z, 5005SC-Z and 6005SC-Z

Solenoid valve A is opened and the other valves are closed. The oil pressure existing in space S, moves the piston towards the right hand direction. The piston can move to the end of its stroke so that the capacity can minimize. With the elimination of the capillary tube in between solenoid valve A and the space S, the actuating speed of the piston may be rapid.

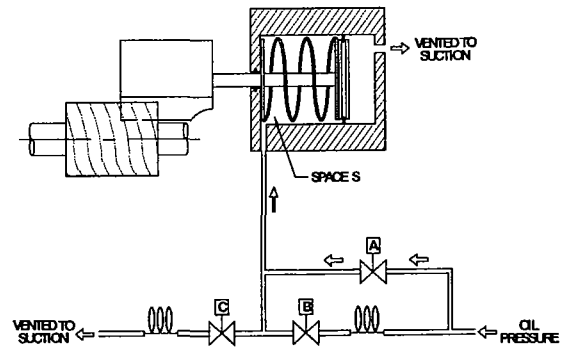

FIGURE 2-7: Minimum Capacity

Load Up

Solenoid valve C is opened and the other valves are closed. The oil pressure, which exists in space S, will be released through the capillary tube by opening solenoid valve C. The piston will move slowly in the left hand direction so that the capacity will load up.

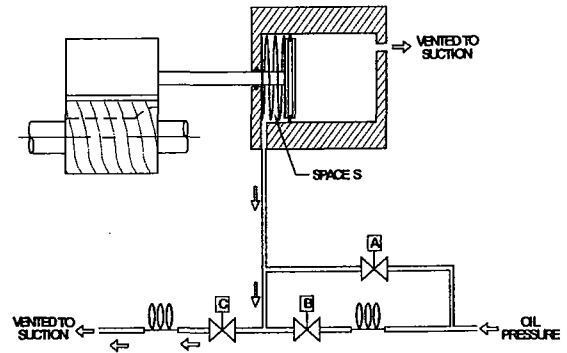

FIGURE 2-8: Loading Up

Load Down

Solenoid valve B is opened and the other valves are closed. The oil pressure, which exists in the space S, actuates the piston towards the right hand direction. The actuating speed of the piston will be slow because there is a capillary tube between the oil source and space S. (See Fig. 2-9)

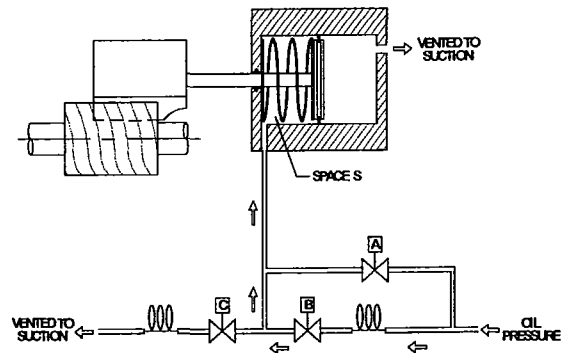

FIGURE 2-9: Unloading

Load Constant

The three solenoid valves are closed. Because all of the solenoid valves are closed, the oil exists in the space S, will be held and the piston will not move. (See Fig. 2-10)

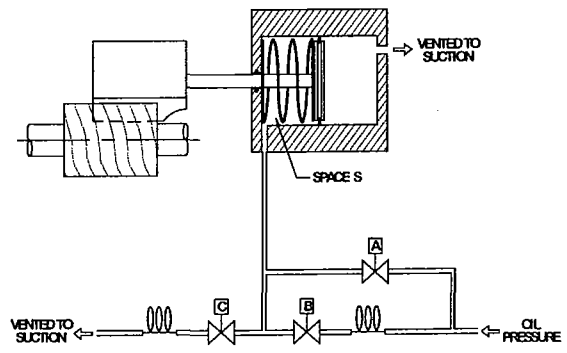

FIGURE 2-10: Load Constant

Location of Solenoid Valves

The location of the three solenoid valves are shown in Fig. 2-5.

Note:

1. Minimum Load:
 33% for 4005SC-Z
 25% for 5005SC-Z and 6005SC-Z

2. A controller for the capacity control system is not included with the compressor.

2-7. Details of Components

(1) Screw Rotors

New asymmetrical profile screw rotors, composed of a five-lobe male screw rotor and a six-interlobe female screw rotor. These screw rotors are machined by a special hobbing and honing machine, with excellent precision, based on strict quality control.

(2) Casing

Double structure construction has been applied to the compressor casings and high-strength inner ribs have been provided in order to minimize noises and to ensure rigidity. The main casing, the discharge casing and the various covers are machined by a computer-aided machining center, to enhance reliability.

(3) Bearings

Radial roller bearings have been installed at both ends of the screw rotors, to support the radial loads. At the discharge end of the screw compressor, triple angular contact ball bearings for the male screw rotor and double ball bearings for the female screw rotor are installed, to support axial thrust loads and to position the screw rotors. Each bearing is lubricated by the oil which is fed from the oil separator.

(4) Suction Strainer

A reinforced strainer is provided at the suction port of the screw compressor.

(5) Semi-hermetic Motor

The two-pole semi-hermetic motors have been specially developed for these screw compressor by HITACHI. The motors are squirrel cage, three phase, two pole, induction type. The motor range is composed of four models 40 HP, 50 HP, 60 HP and 100 HP. The coils of these motors are impregnated with varnish to ensure rigidity against the heavy vibration when the motors are started.

Six terminal lugs on the 4005SC-Z, 5005SC-Z and 6005SC-Z compressor and 12 terminal lugs on 10001SC-Z compressor, for electric power connections, which can be configured for either across-the-line or star-delta starting, are provided in a dust-proof terminal box located at the top of the screw compressor. The four terminals for the motor protectors, which are inserted into the motor stator coils, are provided in a dust-proof cover located at the front side of the motor casing.

(6) Oil Separator

A vessel with a demister is directly connected with the discharge end of the screw compressor, to form one unit. The vessel is installed at the high pressure side of the screw compressor.

3.0 HITACHI Compressor Cores

When a HITACHI compressor is being used as a replacement compressor, it is possible that the core would be of some value. Please contact AC Component Specialists, Inc., to determine if there is any residual core value and to obtain authorization for shipment of the core to ACCS.

Operating Conditions

The following conditions must be observed in order to avoid damage to the compressor. Failure to do so will void the manufacturer's warranty.

Reverse Rotation

Reverse rotation is not permitted under any circumstance. This will damage the screw rotors and void the warranty.

Power and Control Circuits

Magnetic contactor minimum sizing should be selected as follows:

Air-cooled units; $I_{mg} = I_r \times 1.5$

Water-cooled units: $I_{mg} = I_r \times 1.25$

I_{mg} : Rated Capacity of Magnetic Contactor (A)

I_r : Unit Running Current (A)

Any local or national codes that require higher rated contactor selection should be followed.

All control circuits shall be designed to reset manually when the motor protector trips. Do not use an automatic reset system.

Suction and Discharge Pressure

A pump down cycle (when the liquid line is closed to remove refrigerant from the evaporator to the condenser) is not permitted where pump down would allow suction pressure to drop below 7 psig. The discharge pressure shall not exceed 370 psig.

Return Liquid Slugging

No direct return of liquid refrigerant to the compressor is permitted under any conditions.

OPERATIONAL SAFETIES

Electrically Applied Safeties (All Manually Reset)

1. Phase Protection

- Phase Reversal ✓ Must be A-B-C Clockwise
- Voltage Protection ✓ $\pm 10\%$ allowance [i.e. 460V = 414V - 506V]
- Phase Loss ✓ Single Phasing
- Phase Imbalance ✓ less than 3% of average voltage present

2. Overload Protection

- Based on Compressor Rated Load Amps (RLA)

3. Motor Over-Temperature Protection

- Over Temperature Cutout @ 239°F

4. Discharge Gas Temperature

- Safety Cutout @ 248°F

Liquid injection cooling is required above 248°F. Liquid injection cooling extends the discharge gas limit to 266°F. Refer to the Hitachi published details on liquid injection cooling for details on installation.

5. Low Pressure Protection

- ≥ 7 PSIG Safety Cutout

For operation limits refer to the Hitachi published capacity curves.

6. High Pressure Protection

- = 370 PSIG Safety Cutout

For operational limits refer to the Hitachi published capacity curves.

7. Starting and Stopping Limits

- Must not exceed 6 starts per hour
- If started, remain "On" for a minimum of 5 minutes
- Do not restart compressor until it is fully equalized
- Compressor to be started and operated fully unloaded for 30-60 seconds after starting.

OPERATIONAL SAFETIES

Mechanical Safeties and Operational Requirements

1. Discharge Gas Check Valve Required
 - Required to limit the time required for pressure equalization and prevents reverse flow of high pressure gas from the condenser that would result in excessive reverse rotation of the screw rotors.
2. Suction Gas Superheat
 - 9 F° to 27 F° at compressor
3. Discharge Gas Superheat
 - Minimum of 54 F°
4. Oil Requirements
 - Oil visible in the sight glass under all stable operating conditions
 - Minimum of 70 PSIG differential between suction and discharge pressures
 - Crankcase heater to maintain the compressor crankcase at a minimum of 11 F° higher than other components in the system.

PROTECTIVE DEVICES

The HITACHI Semi-Hermetic Horizontal Screw Compressor, as supplied to the United States, does not have the following protective devices. They must be supplied by others in order to ensure proper use of the compressor. ACCS part numbers are included for your reference. All protective safety devices shall be manual reset type.

1. Motor Protector

AC Components has two protector offerings that are UL approved and comply with HITACHI manual reset requirements.

Electronic motor protection module, P/N: MOD1Z04A, is a dual voltage 120/208-240 VAC module that responds to the PTC thermistors embedded in the motor windings to provide motor over-temperature protection.

Electronic motor protection module, P/N: MOD1A02A, is a 24 VAC module that provides the following protection features: Current Overload, Miswire (reverse rotation protection), Current Unbalance, Phase Loss, Motor Winding Over-Temperature and Low Voltage. The module also provides Microcontroller Compatible Current Transducer Output and a Visual Fault Diagnostic Display.

AC Component Specialists, Inc. can install either of these modules in the compressor prior to shipment.

2. Oil Heater (Crankcase Heater)

A crankcase heater must be applied. The diameter of the hole provided is 0.50 inches and 5.51 inches in depth. It is located in the oil sump at the bottom of the compressor casing. The output of the heater is 200 watts. ACCS can supply a 200 watt/120 volt crankcase heater, part number CCH1Z01A.

3. Continuous Capacity Control

The Capacity control is performed by the exchange of oil pressure to the unloader piston. Three oil control solenoid valves (120 volt) are supplied with the compressor. A solenoid valve controller must be employed to adjust capacity. A capacity control microprocessor is available from ACCS. Please call for information and pricing.

4. Reverse Rotation

A check valve must be installed on the discharge piping to prevent reverse rotation during shutdown of the compressor. Electrical phase protection is required to prevent reverse rotation at start-up and to monitor for lost phase.

5. Discharge Temperature Protection

A manual resettable discharge temperature safety switch must be provided in order to limit operation of the compressor when discharge temperatures exceed 248 degrees Fahrenheit. The discharge gas temperature should be sensed on the discharge gas piping at a distance of 9 7/8 inches from the compressor housing.

Pilot Duty Electronic Motor Protection Modules

ACCS Part # MOD1Z04A

The HITACHI Horizontal Screw Compressors, as supplied to the US market (Models 4005SC-Z, 5005SC-Z, 6005SC-Z and 10001SC-Z), are equipped with external electrical connections for the three Positive Temperature Coefficient (PTC) thermistor sensors, which are internally installed in the hermetic motor windings. The following guide is designed to be an aid for the application of an electronic motor protection module, to provide protection against the operation of the compressor above factory allowable temperature limits for the motor.

PTC thermistor sensors contain a conductive ceramic material, whose most useful property is the ability to remain at a low base resistance over a wide temperature band, and to increase abruptly at its trip or switch temperature (Fig. 1). When this abrupt resistance increase occurs, the sensor acts as a solid state thermal switch and provides an input signal to the electronic motor protection module which, in turn, can interrupt power to the starter or contactor coil.

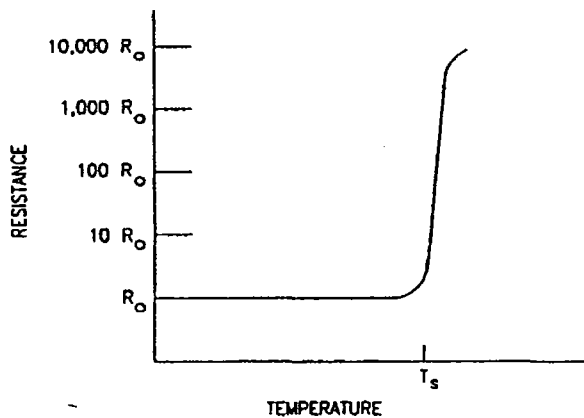

Figure 1

The electronic motor protection module, ACCS stock # MOD1Z04A, available through AC Component Specialists, is a dual supply voltage (120/208-240 VAC) module. It provides a 2.5 amp maximum, at 24/120/240 VAC, dry contact for the safety circuit. Three channels are provided to sense the temperature from each motor winding PTC thermistor. To comply with HITACHI factory requirements, this module is a manual reset type, requiring the removal of supply voltage for a minimum of 5 (five) seconds, in order to reset the circuit. Refer to the following wiring diagram (figure 2), for detailed hookup information.

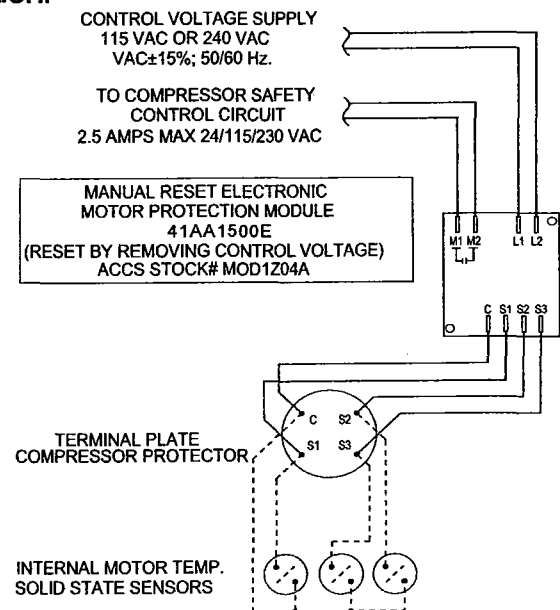

Figure 2

AFTERMARKET SERVICE & REPLACEMENT

High voltage input to one of the three channels of the module, may damage the sensitivity of the module and thus inhibit its ability to protect the compressor motor. Compressors requiring service due to an electrical problem with the motor, should have the electronic motor protection module replaced. If the compressor is replaced, *ACCS highly recommends that the electronic motor protection module be concurrently replaced.*

2ACE ELECTRONIC MOTOR PROTECTION

ACCS P/N MOD1Z02A

The solid state 2ACE module is an economical and reliable protection platform which combines current and thermal overload protection for large three phase motors.

These UL recognized motor protection modules are used with positive temperature coefficient (PTC) thermistors installed in the motor windings. These thermistors exhibit low resistance until their temperature increases to a predetermined trip point. A unique feature of the steep slop PTC is an increase resistance of several orders of magnitude at the trip point. This exponential rise in resistance results in the opening of the 2ACE control relay, which can be wired in series with a starter/contactors coil.

Where locked rotor conditions cause rapid current overload, the response time of thermal protection may not be adequate. The 2ACE module employs a proprietary design with on current sensor per phase that responds to changes in current. By utilizing the control relay, the module can be calibrated for individual applications with a "Must Hold" current range from 25-225 Amps.

The current transducers allow the module to offer added features of phase loss protection, unbalance, and improper phase sequence conditions.

The current transducer can also be used as an accurate, stable device to measure AC current. The 2ACE output is linear over its full scale range of 0-225 Amps, and is independent of load. This low ripple output is achieved by full scale signal conditioning of the transducer, and can be directly connected to a control microprocessor without added filter conditioning.

General Specification

	Units	Minium	Typical	Maximum
Operating Temperature Range	°C	-40		+70
Supply Voltage (Rated 24 VAC at 0.240A Load)	VAC	18	24	30
Rated Line Frequency Utility Regulation		45 56	50 60	55 64
Rated Line Frequency	hZ	45	50/60	62
Low Voltage Cut-Out Trip	V ac	15	16	17
Low Voltage Cut-In Reset	V ac			18
Low Voltage Response Time (Supply 100% to 50%)	SEC	0.150	0.200	0.250

Thermal Motor Specification

Units		
Sensor Trip Resistance	K Ω	13 ± 3
Sensor Reset Resistance	K Ω	3.25 ± 0.5
Sensor Response Time	SEC	0.50 Typical

Current Transducer and Protection Specification

Units		
Sensed Output at B & G Terminal	Vdc mA	0 to 5 Full Scale 4 - 20 Full Scale
Accuracy		± 3% Full Scale
Response (10 to 90%)	Sec	0.150 Typical
Shorted Current Sensor Protection	Ω	<10 Typical
Repeatability		± 1% Full Scale
Current Phase / Unbalance Detection	Load 17% Partial 25% Unload 50%	
Must Hold Calibration Range	A ac	25 to 225
Overload Current Trip Time		MH x 400% : 1.5 Sec.
Phase Misewire Response Time (Improper Sequence)	SEC	1.1 Max
Phase Loss Response Time	SEC	1.0 Max

Detailed Hookup Information for 2ACE Electronic Motor Protection Module ACCS part number MOD1Z02A

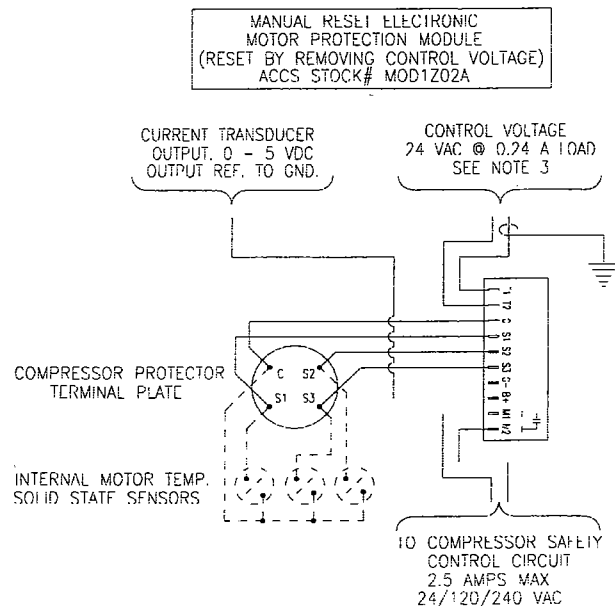

2ACE ELECTRONIC MOTOR PROTECTION FAULT DIAGNOSTIC DISPLAY CODES

DISPLAY VALUE	DEFINITION
0	Normal - no fault detected. Sweeping zero display - consists of turning on & off one led segment sequentially to provide active operation mode.
HA XXX	Normal - Motor off - Current <5 A AC. Must Hold calibration setting displayed. Acceptable range for XXX is 025 - 225
1	Current overload
2	Loaded unbalance / Phase loss ($\geq 17\%$)
3	Unloaded unbalance / Phase loss ($\geq 25\%$)
4	Improper phase sequence
5	Over - Temperature
6	Out of range of Must Hold calibration
7	Unload unbalance
8	Phase loss (>60%)
All Other Alpha Symbols	Internal errors - Contact ACCS

Electrical Phasing for Proper Compressor Rotation

The HITACHI Horizontal Screw Compressors, as supplied to the US market (Models 4005SC-Z, 5005SC-Z, and 6005SC-Z), are factory nameplated for operation at the following voltages:

208 -230 Volt - 3 PH - 60 Hz

460 Volt - 3 PH - 60 Hz

(Model 10001SC-Z) is nameplate for operation at the following voltage:

460 Volt - 3PH - 60 Hz

All models are provided with six terminals for line voltage connections, to allow STAR-DELTA starting. ACROSS-THE-LINE starting is also applicable to the compressor. Please refer to wiring diagrams.

The following guide is designed as an application aid for phasing line voltage connections, which will achieve proper rotation of the HITACHI Horizontal Screw Compressor. Improper phasing and reverse operation of this compressor will void the warranty and damage the compressor.

It is not the intent of this service bulletin to supercede any safety requirements, local codes, or provide an unsafe working environment for the operator while performing these tasks. In many instances, dangerous levels of voltage and current are present, therefore it is important that the operator avoid direct contact with any uninsulated, current-carrying surfaces. Appropriate insulating gloves and clothing should be worn. Before using any electrical instrument or accessory for actual testing, the instrument should be checked on a known live line to make certain it is operating correctly.

For discussion purposes, the text refers to the use of a phase rotation indication meter. Specific instructions, contained herein, apply to a GREENLEE Model 5700 (ACCS Stock # MTR1Z01A). Read and understand all instructions for the indicator of choice before attempting to use it. Insure that the indicator chosen is suitable for use at the supply voltage being tested.

Figure 106.1 represents the HITACHI screw compressor electrical terminal plate assembly, showing the six terminals as provided for STAR-DELTA Starting.

Figure 106.2 represents the HITACHI screw compressor electrical terminal plate assembly, showing the positions of the "Across the Line" Start Kit (ACCS Stock #XLK1A01A) For ACROSS THE LINE Starting.

HITACHI TERMINAL PLATE ASSEMBLIES

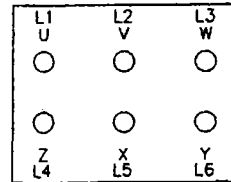

Fig. 106.1

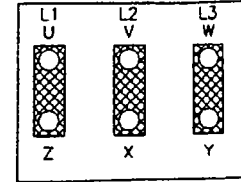

Fig 106.2

- 1) Turn off the main disconnect and lock out. Insure that the voltage is turned off.
- 2) Remove the lead wires from the compressor terminal plate studs. Position the wires so that they are not in contact with the enclosure or with each other.
- 3) Connect the test leads of the phase rotation indicator to the L1, L2 and L3 designated power.
L1, L2, L3 Figure 106.1 & 106.2
L4, L5, L6 Figure 106.1 (ONLY)
- 4) Unlock and turn on the main disconnect.
- 5) Energize the compressor contactor being phased.
- 6) With all three phase indicator lights lit, the phase sequence must indicate a CLOCKWISE rotary field. If it does not indicate a CLOCKWISE rotary field, or if the three phase light indicators are not lit, turn off the incoming power and correct the fault (fuses, breakers, loose connections, etc.) If the indication is a COUNTER CLOCKWISE rotary field, repositioning of the power leads is required in order to achieve a CLOCKWISE rotary. **NEVER CONNECT TEST LEADS TO OR DISCONNECT TEST LEADS FROM A LIVE CIRCUIT.**
- 7) Where 6 power leads are used connect the test leads of the phase rotation indicator to the L4, L5, and L6 designated power leads and repeat steps 4 through 6.
- 8.) When testing is complete, disconnect the power to the circuit and lockout. Disconnect the testing device from the circuit.
- 8) Reconnect the leads wires to the compressor terminal plate assembly so that:
L1(U), L2(V), L3(W) = Clockwise Rotary Field
L4(Z), L5(X), L6(Y) = Clockwise Rotary Field
(if applicable)
- 9) When the compressor is ready to energize, monitor the suction and discharge pressures, at the compressor ports, with a service manifold. When the compressor is idle, the suction and discharge pressure should be equalized. When the compressor is energized, the suction pressure should decrease and the discharge pressure should increase rapidly. If not, disconnect the power immediately and recheck phasing sequence.

OIL MANAGEMENT

1. The oil level should be maintained within the oil sight glass range under steady - state operating conditions. The period with no visible oil in the oil sight glass, under starting and other unstable conditions, **must not exceed 30 seconds**. The oil level in the sight glass should be checked during operation.

NOTE: The oil level might be different between an operating condition and an idle condition.

2. The diameter of the sight glass is 0.86 inches. Please check the oil level in the sight glass in the following manner:

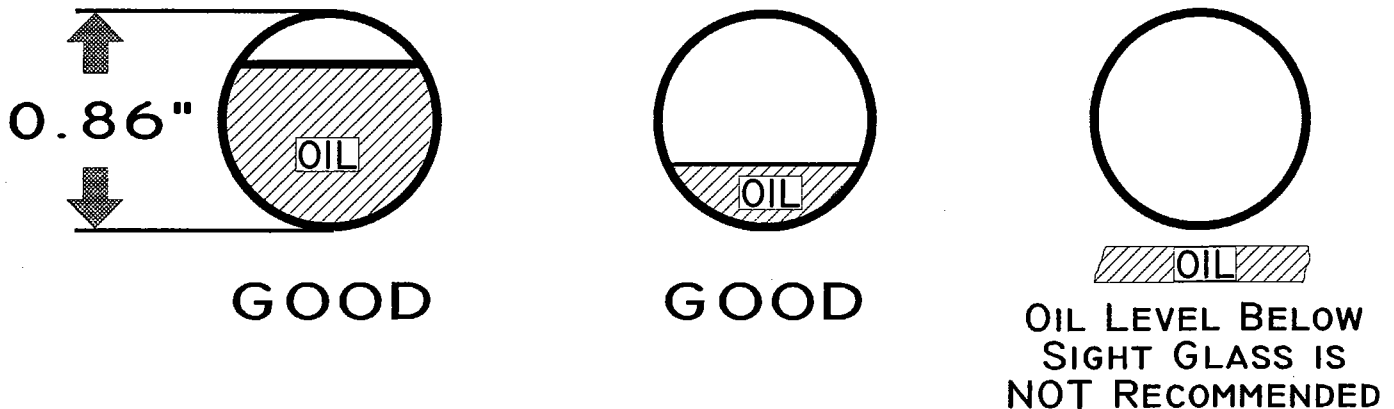

3. In the event of oil disappearance from the sight glass, proceed with these steps:

A. If the oil level returns with 30 seconds after disappearance:

No Action Needed.

B. If the oil level does not return within 30 seconds.

1. **Operate at minimum load.**

If the oil level return within on (1) minute, this indicates the possibility of oil trapped in the system (accumulator, piping etc.). Changes should be made to the system design to insure the return of oil to the compressor.

2. If the oil level does not return within one (1) minute:

Additional oil may be required. Add approximately two (2) liters of additional oil. HITACHI approved oils are available through AC Component Specialists, Inc.

OIL SPECIFICATION AND MAINTENANCE

1. Oil Level

Oil level should be maintained within the oil sight glass range under steady - state operating condition. The period with no oil visible in the oil sight glass, under starting and other unstable conditions, must not exceed 30 seconds.

2. Impurities in the Refrigeration Cycle

2.1 Foreign Particles

If the pressure drop at the suction strainer, or the oil strainer, exceeds 0.3 kg/cm²G (4.3 psi), the amount of foreign particles is considered to be excessive. The refrigeration system design and manufacturing procedures must be reviewed.

For newly designed systems, the lubrication oil must be sampled from the oil chamber after 72 hours and analyzed for impurities (ACCS P/N OTK1A01A).

2.2 System Impurities

Organic compounds, such as trichlene (used for washing the heat-exchangers), acids, and any dust and dirt may cause a harmful chemical reaction. Take precautions to insure that they do not enter the refrigeration system.

2.3 Moisture

Moisture content in the refrigeration system must be less than 200 p.p.m., as determined by the gas chromatograph method or the Carl Fisher method. Contact AC Component Specialists (ACCS) for oil sampling and analysis information.

2.4 Non-Condensing Gas

Non-condensing gas, particularly air and nitrogen gas, must not exceed 2% of the total refrigerant volume in the refrigeration system.

3. Refrigeration Oil for Screw Compressor

3.1 Characteristics of Refrigeration Oil

The HITACHI "005" and 100hp semi-hermetic screw compressor is charged with a specially-developed Castrol Icematic SW220HT oil at the time of shipment. The SW220HT is an ester type synthetic oil and features a high kinematic viscosity under the mixed conditions with refrigerants. Table 1 provides detail on the refrigeration oil.

Table 1
Characteristics of Refrigeration Oil

	Test Method	
Name of Oil	-	ICEMATIC SW220 HT
Supplier	-	Castrol
Kinematic Viscosity	ASTM D445	220mm ² /s(220 cSt)
At 40 °C (104 °F)		19.2mm ² /s(19.2cSt)
At 100 °C (212 °F)		
Pour Point	ASTM D97	-24 °C
Flash Point	ASTM D93	260 °C
Total Acid Number	ASTM D664	Less than 0.15
Color	ASTM D1209	300
Density at 15.6 °C	IP 365	980 kg/m ³

3.2 Oil Charging Quantity

The required oil charge for the screw compressor will vary depending on the design of the refrigeration system (including a condenser, a cooler, a reservoir, an accumulator, etc.). Therefore, oil charging quantity cannot be determined from the compressor data alone. Designers of the refrigeration system should calculate, test and determine oil charging quantity, referring to the following data:

Model	Oil Charge (Liters)
4005SC-Z	6
5005SC-Z	6
6005SC-Z	6
10001SC-Z	10

Oil charge shown above is example of charging quantities for HITACHI water-cooled self-contained water chillers which are equipped with a shell-and-tube type condenser and a dry type cooler.

The standard compressors are charge with oil at the time of shipment. Confirm that the oil is viewed from the oil sight glass under all stable operating conditions.

HITACHI SW220HT OIL

ACCS Part Number OIL1A12A (quart size) - OIL1A21A (gallon size)

With the introduction of the new "005" series and 100 HP Horizontal Screw Compressors for use with refrigerants R-22, R-407C and R-134a, HITACHI made a decision to make available a universal lubricant that would be compatible with all three refrigerants.

HITACHI contracted with Castrol Industrial to develop an enhanced version of their existing Icematic SW-220 that would provide a superior level of protection benefits for the new compressors. Castrol developed Castrol Icematic SW220HT solely for use in HITACHI screw compressors. Castrol Icematic SW220HT is an ISO220 grade synthetic lubricant formulated with select polyol ester (POE) base stocks with an added acid scavenger that acts to bind moisture and neutralize acid and thereby minimize copper plating within the compressor.

System acid is often the by-product of moisture that has entered the system. SW220HT is supplied dry, with a moisture content of typically less than 50 ppm. It is important to follow proper POE oil handling procedures and to minimize the time that the system is open to the atmosphere. POE products are hygroscopic and can absorb up to 1500 ppm of moisture if left open for a short time.

High moisture content can affect the refrigeration system in the following ways:

- ◆ Reduced capacity, affecting performance.
- ◆ Potential for corrosion, limiting compressor life.
- ◆ Potential to cause copper plating, leading to elevated compressor wear.
- ◆ Reduced internal clearances, resulting in elevated operating temperatures.
- ◆ Acid production associated with moisture content may result in motor insulation degradation.

The incorporation of an acid scavenger, for increased compressor life, is but one of many benefits that SW220HT oil provides. Additional benefits include:

- ◆ Universal compatibility with refrigerants R-22, R-407C and R-134a.
- ◆ Outstanding product cleanliness and purity.
- ◆ Long lubricant life with proper maintenance.
- ◆ Superior lubricity and wear protection.
- ◆ Excellent miscibility and fluidity within compressor operating ranges.
- ◆ Excellent high-temperature stability.
- ◆ No adverse health and safety effects when properly handled.

SW220HT is the proper oil for use in the new HITACHI "005" series and 100 HP Horizontal Screw Compressors. Substituting another type or brand of oil would cancel out the many exceptional benefits of this oil, thus compromising the life and reliability of the compressor. The UL listing of these compressors is based on the use of SW220HT lubricant. Using any oil other than SW220HT in the HITACHI "005" series and 100 HP Horizontal Screw Compressors will void the factory compressor warranty.

RETROFIT INSTALLATION KIT "KIT1A08A"

When replacing an earlier model of the HITACHI screw compressor with the new "005" series compressor, careful handling of an oil change to the refrigeration system must be accomplished. As much old lubricant as possible should be removed from the system prior to the installation of the replacement compressor. The supplied SW220HT oil charge in the "005" series compressor should be used during the initial operation of the compressor on the old system. Insure that the appropriate box is marked on the nameplate for the refrigerant in use (Figure 1). Operate the replacement compressor for a minimum of 40 operational hours, insuring that oil remains visible in the compressor sight glass under all stable operational conditions.

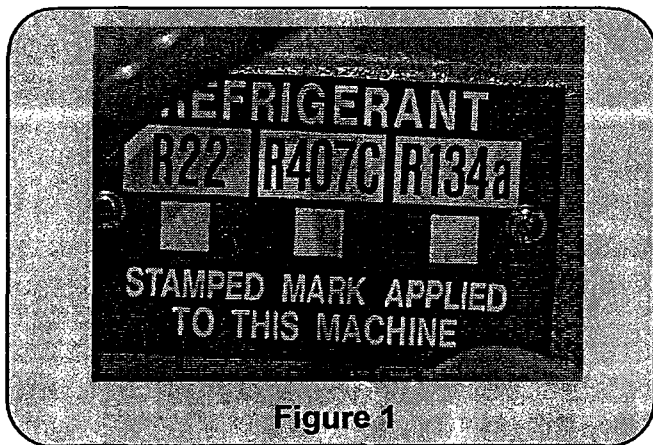

Figure 1

Remove the oil charge from the compressor, check cleanliness of strainer, change out the oil strainer plate gasket and strainer o-ring and recharge with fresh SW220HT Refrigeration Lubricant [Gasket, o-ring and two one-gallon containers of SW220HT lubricant are provided in the ACCS "005" Series Retrofit Installation Kit KIT1A08A (see Figure 2) and should be adequate for each compressor model]. Operate the compressor for a minimum of 20 operational hours and sample the lubricant with an ACCS Oil Test Kit (also included in the retrofit installation kit). Follow the instructions included with the kit for oil analysis.

Figure 2 shows the individual components that make up the ACCS Stock #KIT1A08A. Each part is also available for individual sale.

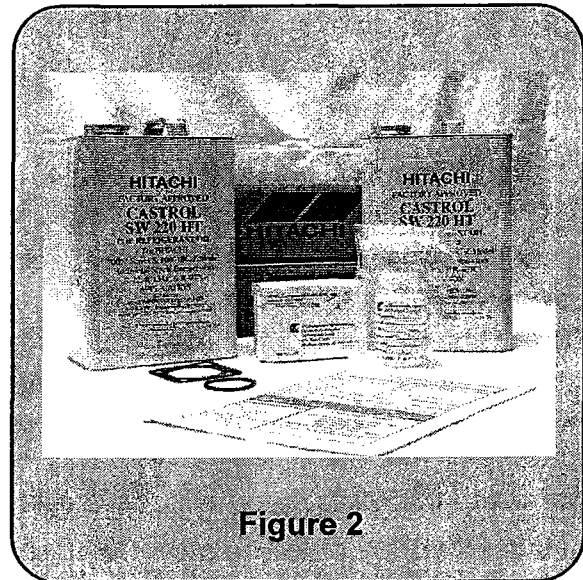

Figure 2

ACCS Stock # KIT1A08A contents:

Qty	Description
1	Oil Strainer Gasket
1	O-Ring Strainer
2	1 Gal Container Refrigerant Oil
1	Oil Test Kit
1	MSDS Sheet / SW220 HT

SAFETY PRECAUTIONS

In performing any work on the compressor or the associated refrigeration equipment, proper safety procedures must ALWAYS be observed. Procedures include, but may not be limited to, the following:

- 1) Only qualified refrigeration mechanics familiar with the HITACHI compressor maintenance procedures should attempt any service to the HITACHI compressor.*
- 2) The compressor may be hot from operation and the oil contained therein will also be hot, allow the compressor and the oil to cool to room temperature before beginning any service to prevent burns.*
- 3) Remove and lockout all sources of power from the compressor to prevent accidental restart.*
- 4) Isolate the compressor from the refrigeration system.*
- 5) Recover the refrigerant from the compressor.*
- 6) Check to confirm that the pressure within the compressor is at no more than 2 or 3 psig above atmospheric pressure before any service is begun.*
- 7) Adherence to all national environmental requirements and local codes and ordinances is vital. It is not the intent of this bulletin to supercede any governing codes or safety practices while performing the service outlined herein.*

MAIN SUPPLY VOLTAGE (SPECIFY WHEN ORDERING COMPRESSOR)
 230V, 60 HZ., 3 PH
 460V, 60 HZ., 3 PH
 L1 L2 L3

REVISIONS				
REV	DESCRIPTION	BY	DATE	APPROVED
A	REVISED NOTES # 1 & 4	RSI	24 OCT 00	PMc
B	REVISED T-PLATE TO REFLECT ACTUAL LAYOUT	RSI	12 FEB 01	PMc
C	UPDATED MOTOR PROTECTION MODULE	RSI	4/12/02	RSI

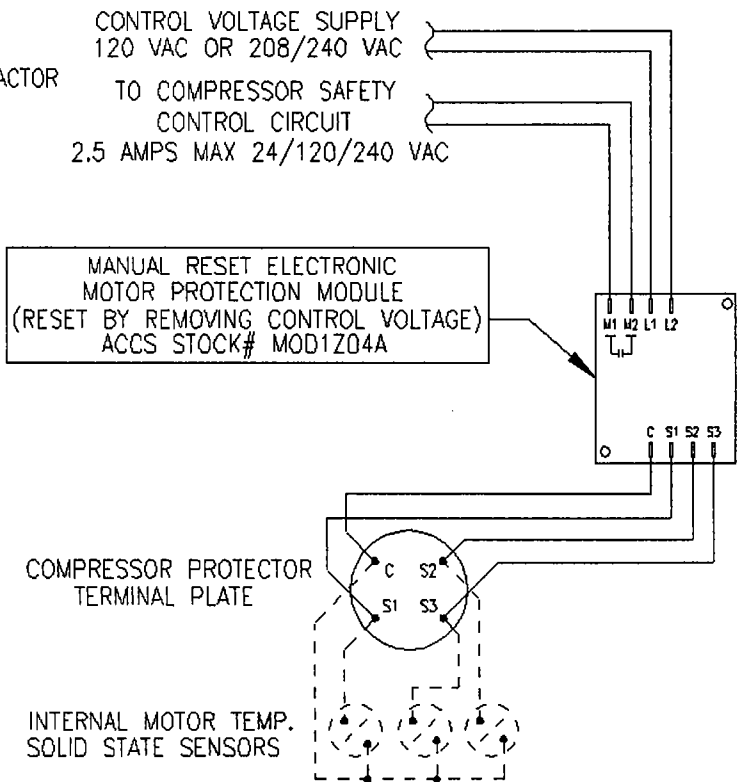
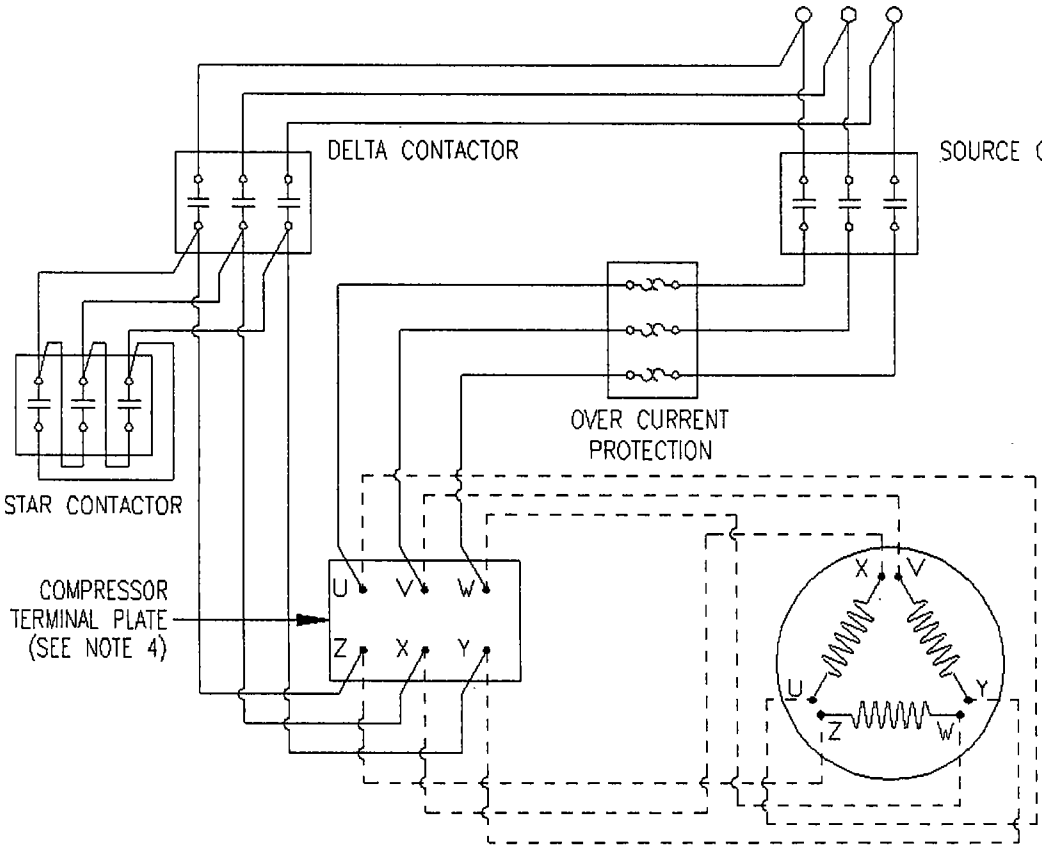

25

- NOTES:
1. STAR OPERATION = 5 SECONDS; CONTACTOR PICKUP & RELEASE <0.035 SEC.
 2. PHASE ROTATION, L2 MUST FOLLOW L1.
 3. OVER CURRENT PROTECTION SELECTION BASED ON THE FOLLOWING CHART:

MODEL NO.	460-3-60	230-3-60
4005SC-Z	50 AMP	94 AMP
5005SC-Z	55 AMP	118 AMP
6005SC-Z	66 AMP	127 AMP

4. TORQUE ALL TERMINAL PLATE CONNECTIONS TO 21.7 FT-LBS.

<p>AC <small>TM</small> COMPONENT SPECIALISTS</p>	TITLE: HITACHI 4005, 5005 & 6005SC-Z COMPRESSOR STAR-DELTA WIRING WITH ACCS P/N MOD1Z01A MOTOR PROTECTION MODULE AND OVER CURRENT PROTECTION SETTINGS	
	P. O. Box 500 899 S. Prairie Lane Morshfield, MO 65706 Phone: (417) 859-6067 Fax: (417) 859-2109	DWG NO. 01010168 DATE: 11 APR 2000 SCALE: NONE

26

460V, 60 HZ., 3 PH

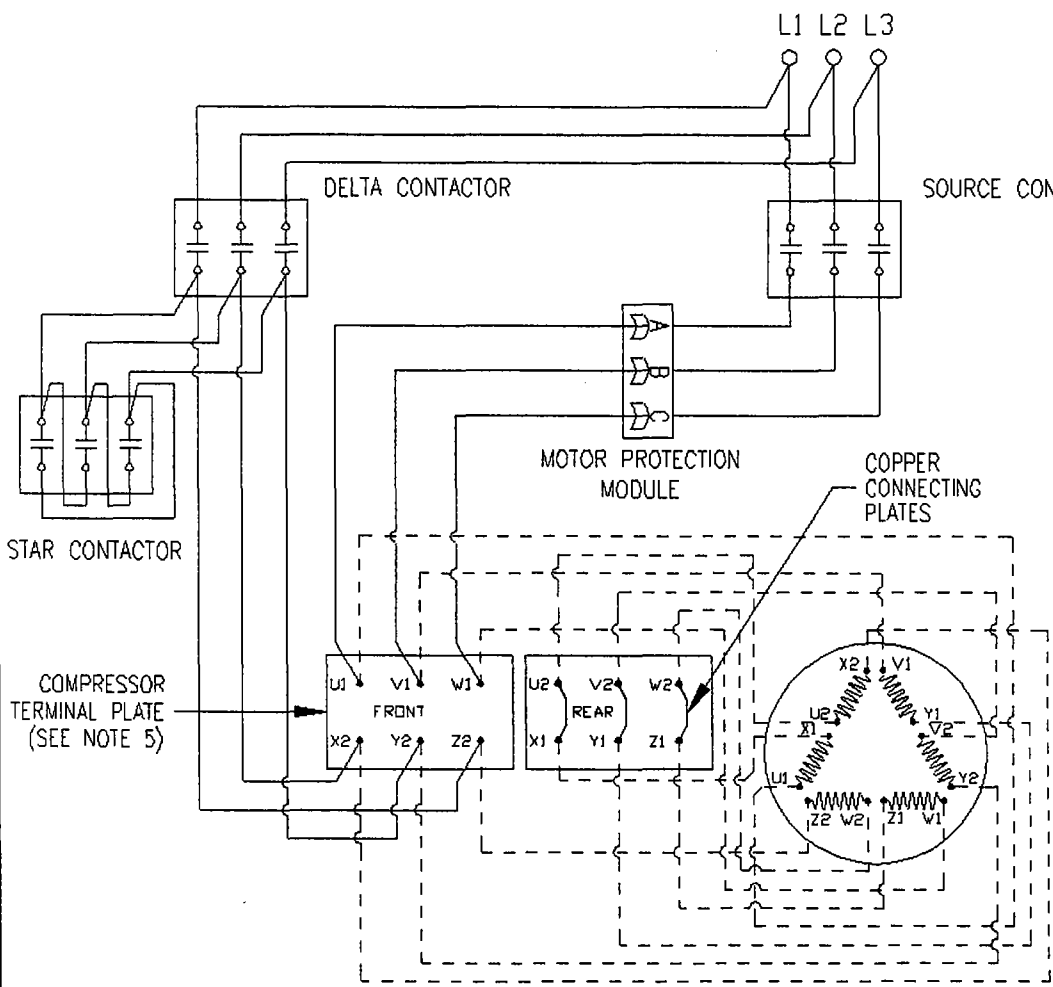

REVISIONS				
REV	DESCRIPTION	BY	DATE	APPROVED
A	REVISED NOTES # 1 & 5	RSI	24 OCT 00	PMc
B	ELIMINATED "G" CONNECTION	RSI	27 NOV 00	PMc

MANUAL RESET ELECTRONIC
MOTOR PROTECTION MODULE
(RESET BY REMOVING CONTROL VOLTAGE)
ACCS STOCK# MOD1Z02A

CURRENT TRANSDUCER
OUTPUT, 0 - 5 VDC
OUTPUT REF. TO GND.

CONTROL VOLTAGE
24 VAC @ 0.24 A LOAD
(SEE NOTE 4)

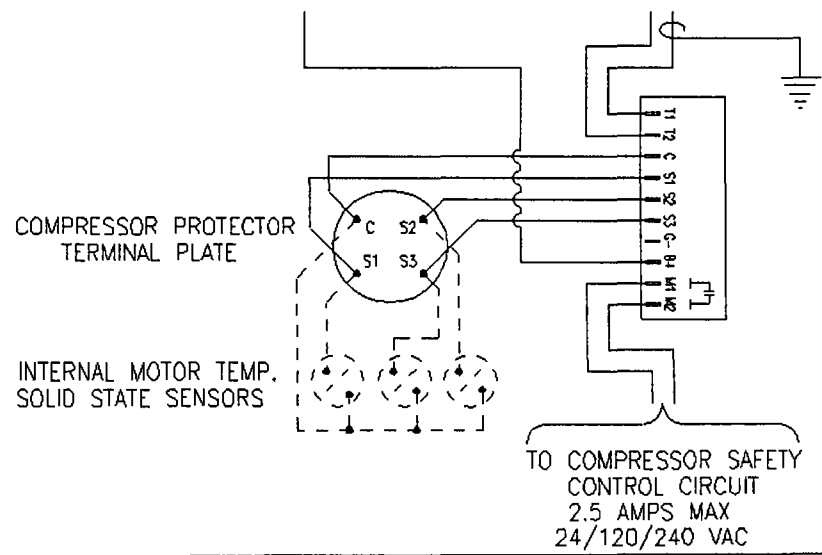

- NOTES:
1. STAR OPERATION = 5 SECONDS; CONTACTOR PICKUP & RELEASE <0.035 SEC.
 2. OVER CURRENT PROTECTION SELECTED AT 104 AMPS.
 3. PHASE ROTATION, L2 MUST FOLLOW L1.
 4. T1 MUST BE REFERENCED TO GROUND @ 24 VAC TRANSFORMER
 5. TORQUE ALL TERMINAL PLATE CONNECTIONS TO 21.7 FT-LBS.

<p>COMPONENT SPECIALISTS</p>	<p>TITLE: HITACHI 10001SC-Z COMPRESSOR 460 VOLT - 3 PHASE - 60 HZ. STAR-DELTA MOTOR WIRING WITH ACCS P/N MOD1Z02A MOTOR PROTECTION MODULE</p>	
	<p>DRG NO. 01010167</p>	<p>DATE 11 APR 2000</p>
<p>P. O. Box 500 899 S. Prairie Lane Marshfield, MO 65706 Phone: (417) 859-6067 Fax: (417) 859-2109</p>	<p>SCALE: NONE</p>	<p>DRAWN BY: RSI CHECKED BY: PMc</p>
<p>REV: B</p>	<p>SHEET: 1 OF 1</p>	

460V, 60 HZ., 3 PH

REVISIONS				
REV	DESCRIPTION	BY	DATE	APPROVED
A	REVISED NOTES # 1 & 4	PSI	24 OCT 00	PMc
B	UPDATED MOTOR PROTECTION MODULE	PSI	4/12/02	PSI

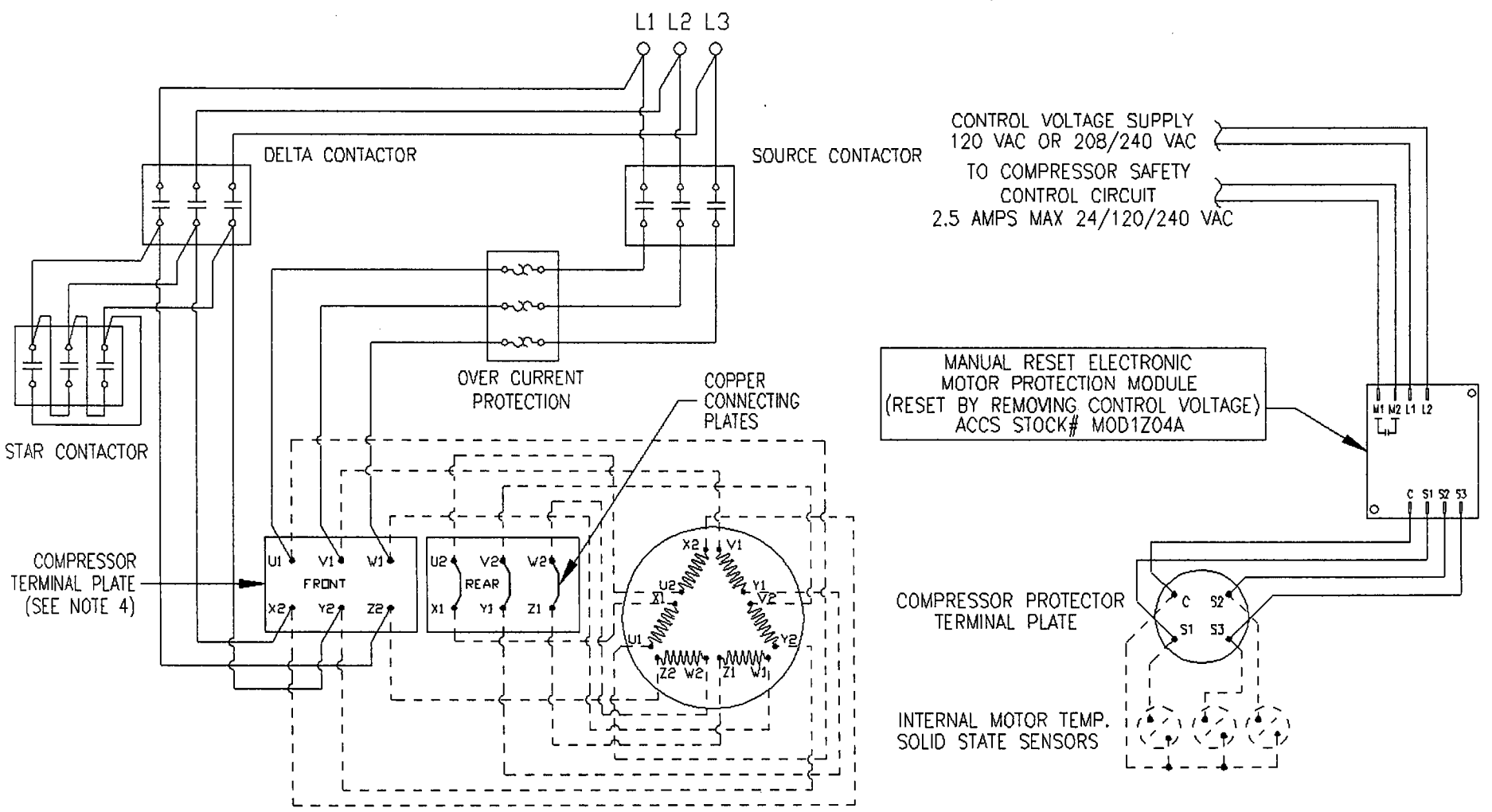

- NOTES:
1. STAR OPERATION = 5 SECONDS; CONTACTOR PICKUP & RELEASE <0.035 SEC.
 2. OVER CURRENT PROTECTION SELECTED AT 104 AMPS.
 3. PHASE ROTATION, L2 MUST FOLLOW L1.
 4. TORQUE ALL TERMINAL PLATE CONNECTIONS TO 21.7 FT-LBS.

 COMPONENT SPECIALISTS	TITLE HITACHI 10001SC-Z COMPRESSOR 460 VOLT - 3 PHASE - 60 HZ. STAR-DELTA MOTOR WIRING WITH ACCS P/N MOD1Z01A MOTOR PROTECTION MODULE		
	P. O. Box 500 899 S. Prairie Lane Horseshoe, MD 65706 Phone: (417) 859-6067 Fax: (417) 859-2109	DWG NO. 01010169	DRAWN BY: RSI
DATE: 11 APR 2000	SCALE: NONE	CHECKED BY: PMc	SHEET: 1 OF 1

MAIN SUPPLY VOLTAGE (SPECIFY WHEN ORDERING COMPRESSOR)

230V, 60 HZ., 3 PH
460V, 60 HZ., 3 PH

L1 L2 L3

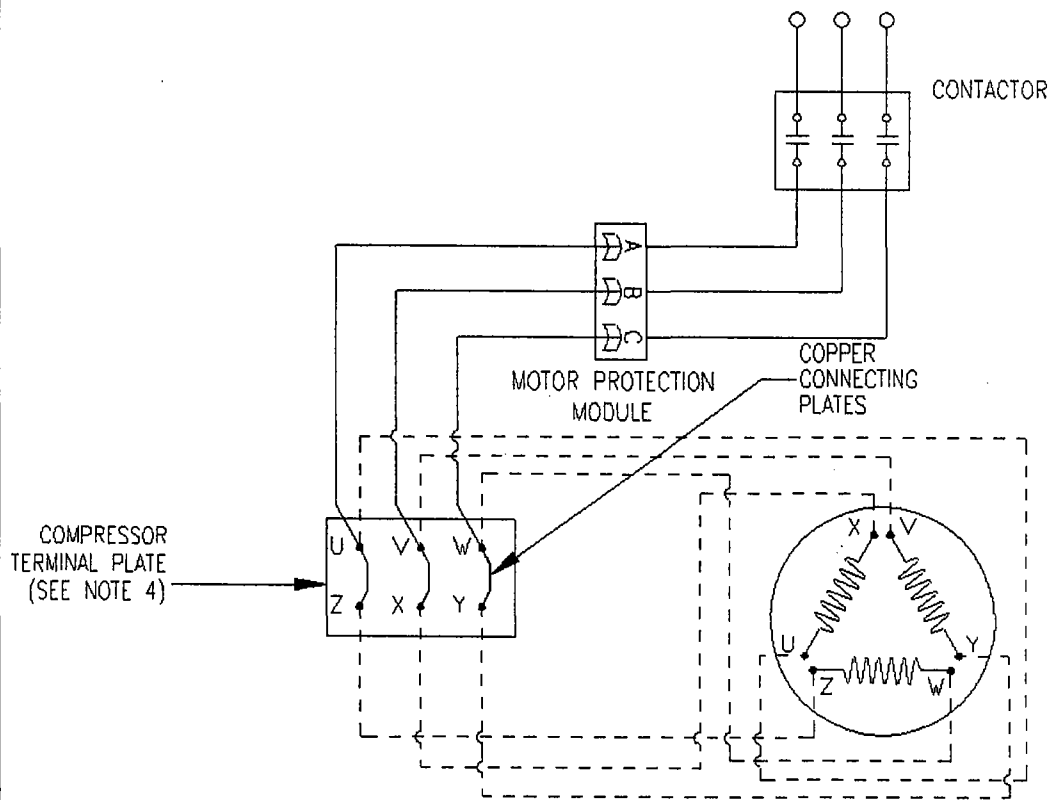

REVISIONS				
REV	DESCRIPTION	BY	DATE	APPROVED
A	REVISED NOTE #4	RSI	24 OCT 00	PMC
B	ELIMINATED "O" CONNECTION	RSI	27 NOV 00	PMC
C	REVISED T-PLATE TO REFLECT ACTUAL LAYOUT	RSI	12 FEB 01	PMC

MANUAL RESET ELECTRONIC
MOTOR PROTECTION MODULE
(RESET BY REMOVING CONTROL VOLTAGE)
ACCS STOCK# MOD1Z02A

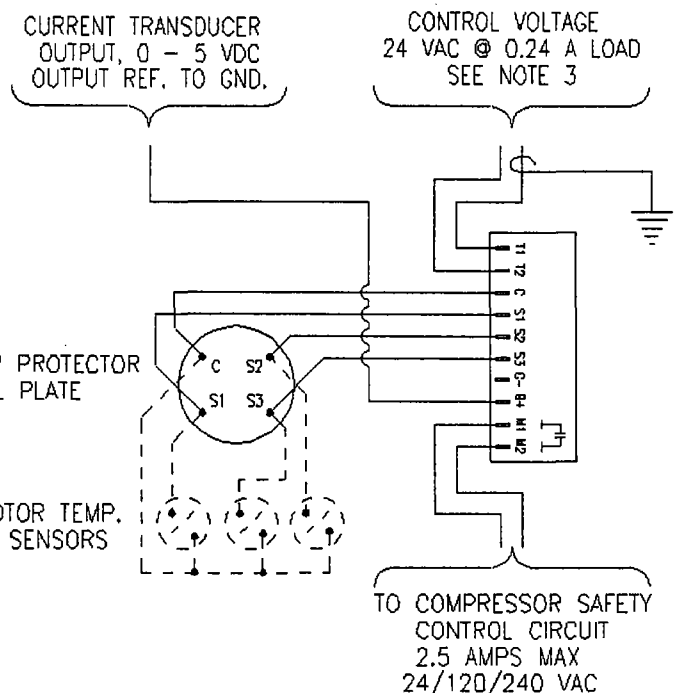

28

- NOTES:
1. PHASE ROTATION, L2 MUST FOLLOW L1.
 2. OVER CURRENT PROTECTION SELECTION BASED ON THE FOLLOWING CHART:

MODEL NO.	460-3-60	230-3-60
4005SC-Z	87 AMP	163 AMP
5005SC-Z	95 AMP	205 AMP
6005SC-Z	115 AMP	220 AMP

3. T1 MUST BE REFERENCED TO GROUND @ 24 VAC TRANSFORMER
4. TORQUE ALL TERMINAL PLATE CONNECTIONS TO 21.7 FT.-LBS.

<p>COMPONENT SPECIALISTS</p>	TITLE: HITACHI 4005, 5005 & 6005SC-Z COMPRESSOR, ACROSS THE LINE START, ACCS P/N MOD1Z02A MOTOR PROTECTION MODULE AND OVER CURRENT PROTECTION SETTINGS	
	P. O. Box 500 899 S. Prairie Lane Morsefield, MO 65706 Phone: (417) 859-6067 Fax: (417) 859-2109	DWG NO. 01010170 DATE: 11 APR 2000 SCALE: NONE

REVISIONS				
REV	DESCRIPTION	BY	DATE	APPROVED
A	REVISED NOTES # 3	RSI	24 OCT 00	PMc
B	UPDATED MOTOR PROTECTION MODULE	RSI	4/12/02	RSI

460V, 60 HZ., 3 PH

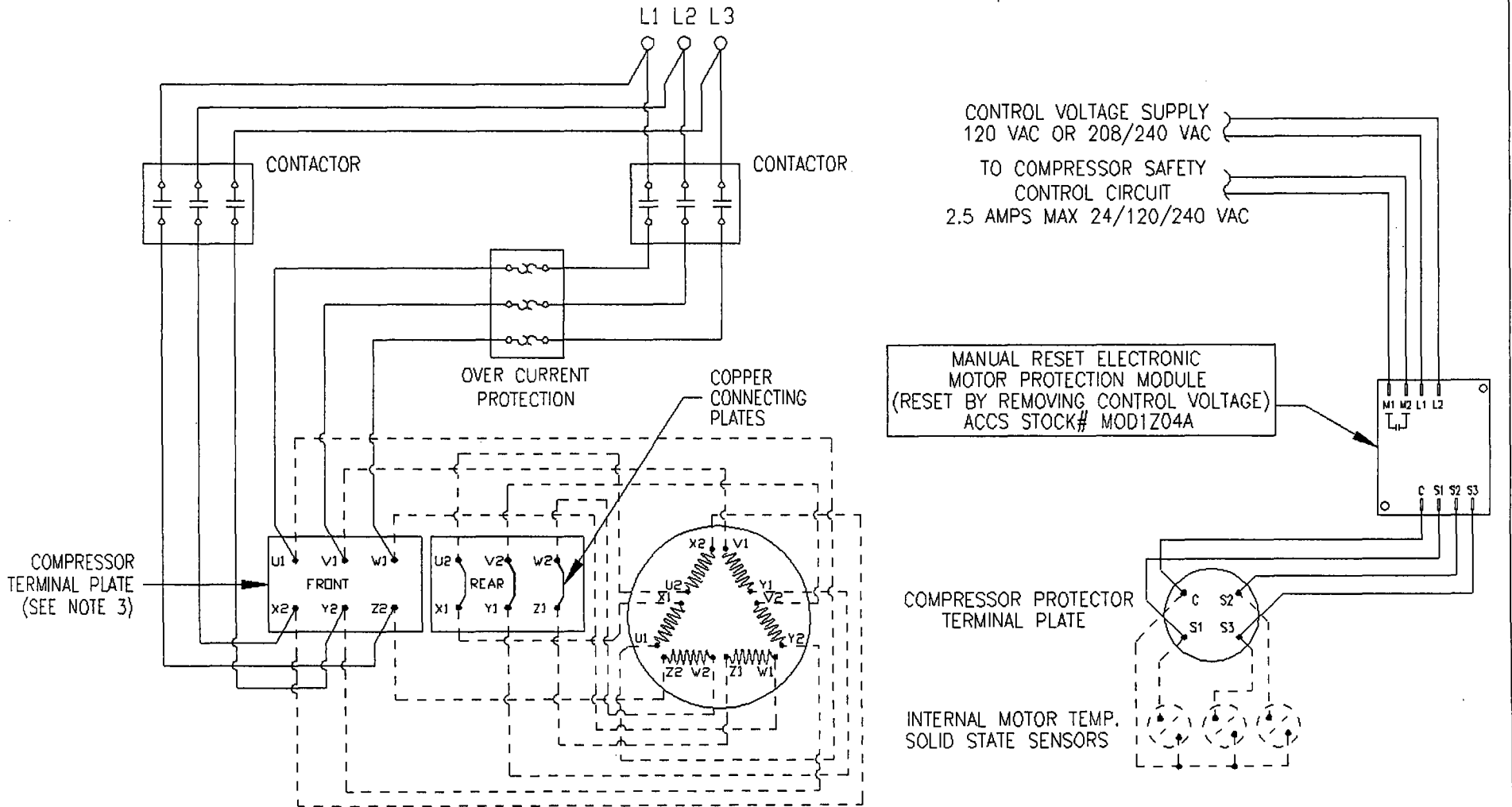

MANUAL RESET ELECTRONIC
MOTOR PROTECTION MODULE
(RESET BY REMOVING CONTROL VOLTAGE)
ACCS STOCK# MOD1Z04A

COMPRESSOR PROTECTOR
TERMINAL PLATE

INTERNAL MOTOR TEMP.
SOLID STATE SENSORS

- NOTES:
1. OVER CURRENT PROTECTION SELECTED AT 104 AMPS.
 2. PHASE ROTATION, L2 MUST FOLLOW L1.
 3. TORQUE ALL TERMINAL PLATE CONNECTIONS TO 21.7 FT-LBS.



COMPONENT SPECIALISTS
P. O. Box 500
899 S. Prairie Lane
Morsefield, MO 65706
Phone: (417) 859-6067
Fax: (417) 859-2109

TITLE: HITACHI 10001SC-Z COMPRESSOR
460 VOLT - 3 PHASE - 60 HZ.
ACROSS THE LINE START WITH
ACCS P/N MOD1Z01A MOTOR
PROTECTION MODULE

DWG NO	01010173	DRAWN BY	RSI	REV:	B
DATE:	11 APR 2000	SCALE:	NONE	CHECKED BY:	PMc
				SHEET:	1 OF 1

REVISIONS

REV	DESCRIPTION	BY	DATE	APPROVED

460V, 60 HZ., 3 PH

L1 L2 L3

CONTACTOR

TERMINAL BLOCK

OVER CURRENT PROTECTION

COPPER CONNECTING PLATES

COMPRESSOR TERMINAL PLATE (SEE NOTE 3)

CONTROL VOLTAGE SUPPLY
120 VAC OR 208/240 VAC
TO COMPRESSOR SAFETY CONTROL CIRCUIT
2.5 AMPS MAX 24/120/240 VAC

MANUAL RESET ELECTRONIC MOTOR PROTECTION MODULE (RESET BY REMOVING CONTROL VOLTAGE) ACCS STOCK# MOD1Z04A

COMPRESSOR PROTECTOR TERMINAL PLATE

INTERNAL MOTOR TEMP. SOLID STATE SENSORS

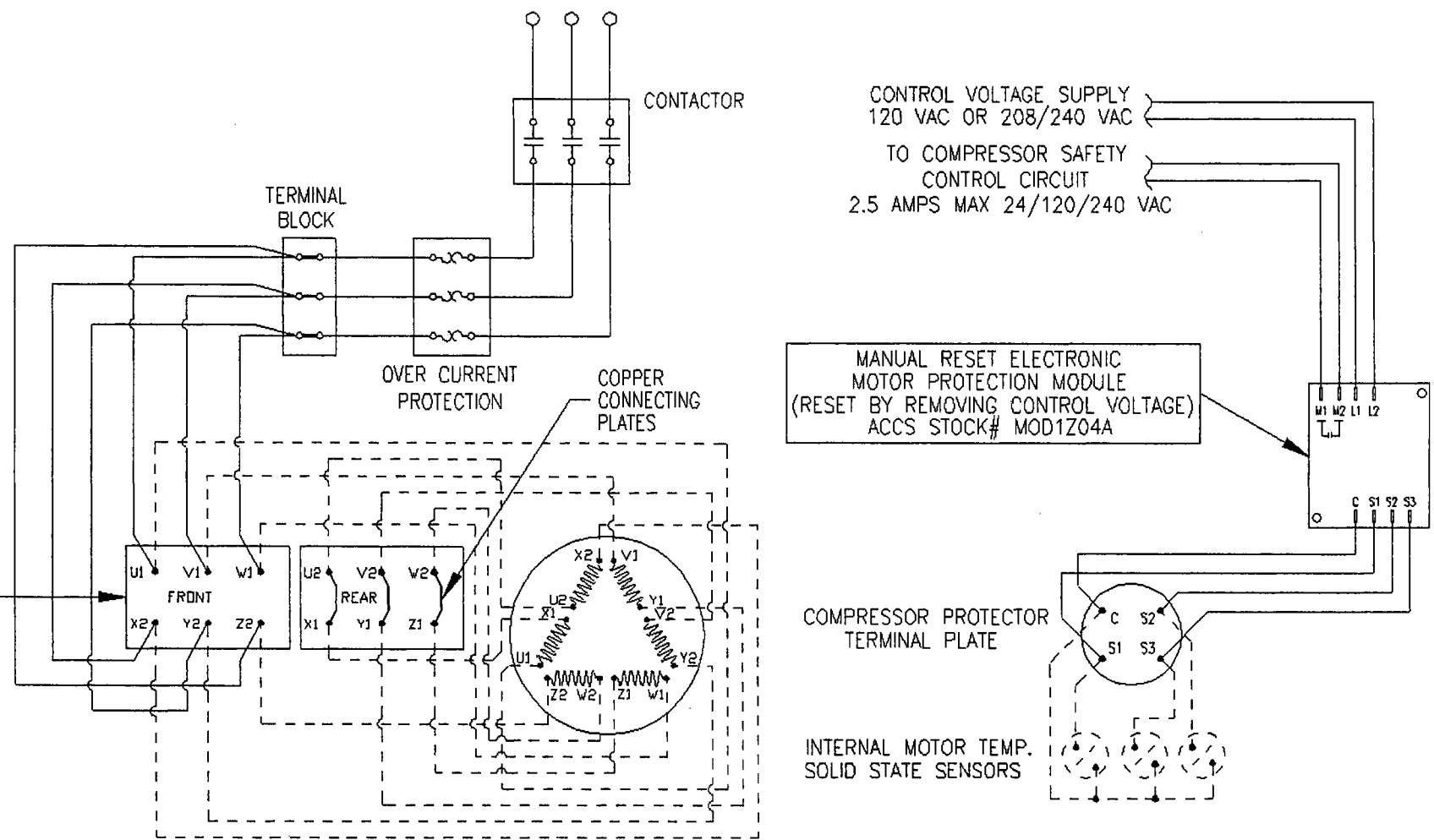

NOTES:

1. OVER CURRENT PROTECTION SELECTED AT 180 AMPS.
2. PHASE ROTATION, L2 MUST FOLLOW L1.
3. TORQUE ALL TERMINAL PLATE CONNECTIONS TO 21.7 FT-LBS.

 <p>AC COMPONENT SPECIALISTS</p>	<p>TITLE: HITACHI 10001SC-Z COMPRESSOR 460 VOLT - 3 PHASE - 60 HZ. ACROSS THE LINE START WITH ACCS P/N MOD1Z04A MOTOR PROTECTION MODULE, SINGLE CONTACTOR</p>		
	<p>P. O. Box 500 899 S. Prairie Lane Morshfield, MD 21706 Phone: (417) 859-6067 Fax: (417) 859-2109</p>	<p>DWG NO. 01010199</p>	<p>DATE: 08 NOV 2001</p>
<p>DRAWN BY: RSI</p>	<p>CHECKED BY: DPD</p>	<p>REV. -</p>	<p>SHEET: 1 OF 1</p>

30

MAIN SUPPLY VOLTAGE (SPECIFY WHEN ORDERING COMPRESSOR)

230V, 60 HZ., 3 PH

460V, 60 HZ., 3 PH

L1 L2 L3

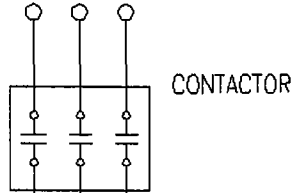

CONTACTOR

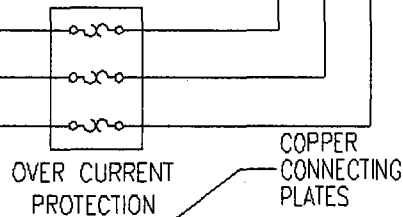

COMPRESSOR
TERMINAL PLATE
(SEE NOTE 3)

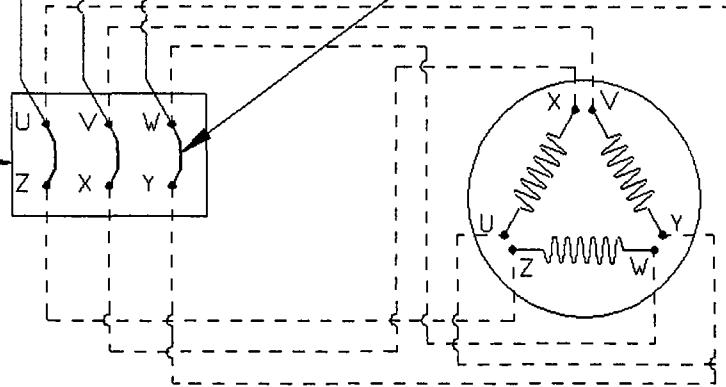

REVISIONS				
REV	DESCRIPTION	BY	DATE	APPROVED
A	REVISED NOTES # 3	RSI	24 OCT 00	PMc
B	REVISED T-PLATE TO REFLECT ACTUAL LAYOUT	RSI	12 FEB 01	PMc
C	UPDATED MOTOR PROTECTION MODULE	RSI	4/12/02	RSI

CONTROL VOLTAGE SUPPLY
120 VAC OR 208/240 VAC
TO COMPRESSOR SAFETY
CONTROL CIRCUIT
2.5 AMPS MAX 24/120/240 VAC

MANUAL RESET ELECTRONIC
MOTOR PROTECTION MODULE
(RESET BY REMOVING CONTROL VOLTAGE)
ACCS STOCK# MOD1Z04A

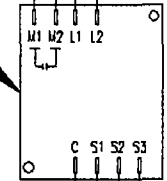

COMPRESSOR PROTECTOR
TERMINAL PLATE

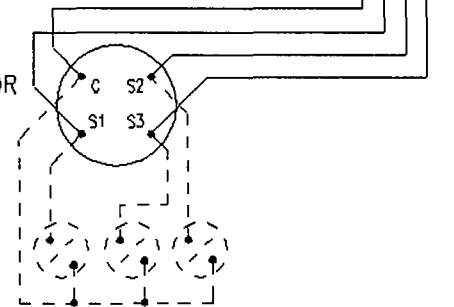

INTERNAL MOTOR TEMP.
SOLID STATE SENSORS

NOTES:

1. PHASE ROTATION, L2 MUST FOLLOW L1.
2. OVER CURRENT PROTECTION SELECTION BASED ON THE FOLLOWING CHART:

MODEL NO.	460-3-60	230-3-60
4005SC-Z	87 AMP	163 AMP
5005SC-Z	95 AMP	205 AMP
6005SC-Z	115 AMP	220 AMP

3. TORQUE ALL TERMINAL PLATE CONNECTIONS TO 21.7 FT-LBS.



P. O. Box 500
899 S. Prairie Lane
Morshfield, MD 65706
Phone: (417) 859-6067
Fax: (417) 859-2109

TITLE: HITACHI 4005, 5005 & 6005SC-Z
COMPRESSOR, ACROSS THE LINE
START, ACCS P/N MOD1Z01A MOTOR
PROTECTION MODULE AND OVER
CURRENT PROTECTION SETTINGS

DWG NO. 01010172	DRAWN BY: RSI	REV: C
DATE: 11 APR 2000	CHECKED BY: PMc	SHEET: 1 OF 1

PERMISSIBLE VOLTAGE RANGE

The HITACHI Horizontal Screw Compressors, as supplied to the US market are factory nameplated for operation at the following voltages:

	C o m p r e s s o r M o d e l N u m b e r			
V o l t a g e	4 0 0 5	5 0 0 5	6 0 0 5	1 0 0 0 1
2 0 8 - 3 - 6 0	✓	✓	✓	N / A
2 3 0 - 3 - 6 0	✓	✓	✓	N / A
4 6 0 - 3 - 6 0	✓	✓	✓	✓

The following guide is designed as an application aid for determining the permissible voltage ranges for the HITACHI Screw Compressor.

The permissible voltage range for the compressor includes a safety factor of $\pm 10\%$. The following chart will illustrate the application voltage ranges as approved by HITACHI for the US Horizontal Screw Compressor. Since the 460 VOLT-3 PH-60 HZ nameplated compressor utilizes the same motor as the 400 VOLT-3 PH-50 HZ compressor, supplied other than to the US market, its permissible operating voltage range in the 50 HZ market is shown in the upper section of the chart.

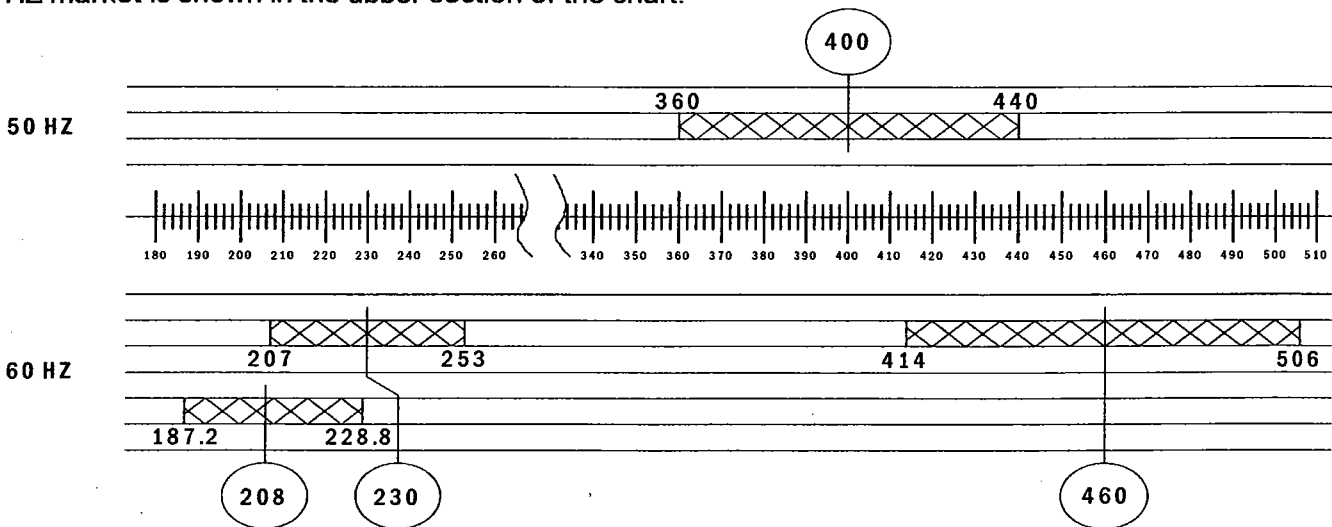

Operation of the HITACHI Screw Compressor below the permissible voltage range may lead to the following malfunctions:

- * Lack of motor output torque - motor does not rotate.
- * Motor coil temperature rise
- * Motor burnout

The HITACHI Screw Compressors are UL approved. The UL approved motor, internal to these compressors, have three thermistors buried in the motor windings to monitor the winding temperature. The output of the thermistors is monitored by a 3 channel electronic motor protection module (ACCS stock #MOD1ZO2A or #MOD1ZO4A) to provide protection against motor over-temperature. HITACHI Screw Compressors supplied other than to the US market, may not carry the UL approval and may be protected by other types of winding temperature sensors.

GENERAL PRODUCT INFORMATION

Model		4005SC-Z	5005SC-Z	6005SC-Z	10001SC-Z
Cooling Capacity (R22)	kW	159.6	196.9	242.6	405.0
	(kcal/h) Btu/h	(137,200) 544,200	(169,300) 671,700	(208,600) 827,700	(348,200) 1,381,600
Motor Input	kW	39.0	48.0	59.5	84.3
Overall Dimension	Height	566 (22-1/4)	591 (23-1/4)	591 (23-1/4)	698 (27-1/2)
	Width	413 (16-1/4)	455 (17-7/8)	455 (17-7/8)	724 (28-1/2)
	Length	1123 (45)	1209 (47-1/4)	1239 (48-3/8)	1537 (60-1/2)
Net Weight	kg (lb)	360 (795)	420 (925)	440 (970)	825 (1819)
Displacement	m ³ /h (cfm)	165.6 (97.5)	204.2 (120.2)	251.5 (148.0)	395.0 (232.5)
Piping connections	Suction Piping O.D.	53.98 (2-1/8)	53.98 (2-1/8)	53.98 (2-1/8)	92.08 (3-5/8)
	Discharge Piping O.D.	34.92 (1-3/8)	41.28 (1-5/8)	41.28 (1-5/8)	66.68 (2-5/8)

Notes:

1. The compressors are driven by two pole motors directly mounted on the compressor shaft, and with a rotation of 3,470 rpm for 60 Hz, at the rated voltage.
2. Refrigerants R22, R407C and R134a are applicable to the these compressors. Continue to use with only one refrigerant that is chosen at the installation.
3. Castrol Icematic® SW220HT Oil is charged in these compressors at the time of shipment.
4. Capacity control is applicable down to 25% (33% for model 4005SC-Z) of the rated capacity.
5. The standard color is light green (Munsell Code 10G5/2).
6. The cooling capacity and the motor input are based on the following conditions:
 - Condensing Temperature: 40.6 °C (105° F)
 - Leaving Liquid Temperature: 40.6 °C (105° F)
 - Evaporating Temperature: 4.4 °C (40° F)
 - Suction Gas Temperature to compressor: 12.8 °C (55° F)
7. The U.S. dimensions shown here are converted from metric.
8. These compressors should be install indoors or in a location equivalent to an indoor environment.

Caution:

UL approval for the 100hp (model: 10001SC-Z) is for 460 V - 60Hz only. The 230/208 V-60Hz UL approval has not been obtained.

Due to continuing improvements, specifications are subject to change. Please consult AC Component Specialists, Inc.

STANDARD TORQUE

Model: 4005SC-Z, 5005SC-Z, 6005SC-Z and 10001SC-Z Standard Torque Values

DESCRIPTION	Model: 4005SC-Z, 5005SC-Z, and 6005SC-Z	Model: 10001SC-Z
Suction Flange Bolts	37.0 FT./LBS	148.0 FT./LBS
Discharge Flange Bolts	74.0 FT./LBS	74.0 FT./LBS
Oil Strainer Cover Bolts	36.1 FT./LBS	36.1 FT./LBS
Electrical Terminal Nuts	22.0 FT./LBS	22.0 FT./LBS
Power Terminal Bolt	36.0 FT./LBS	36.0 FT./LBS

Electrical Terminal Posts

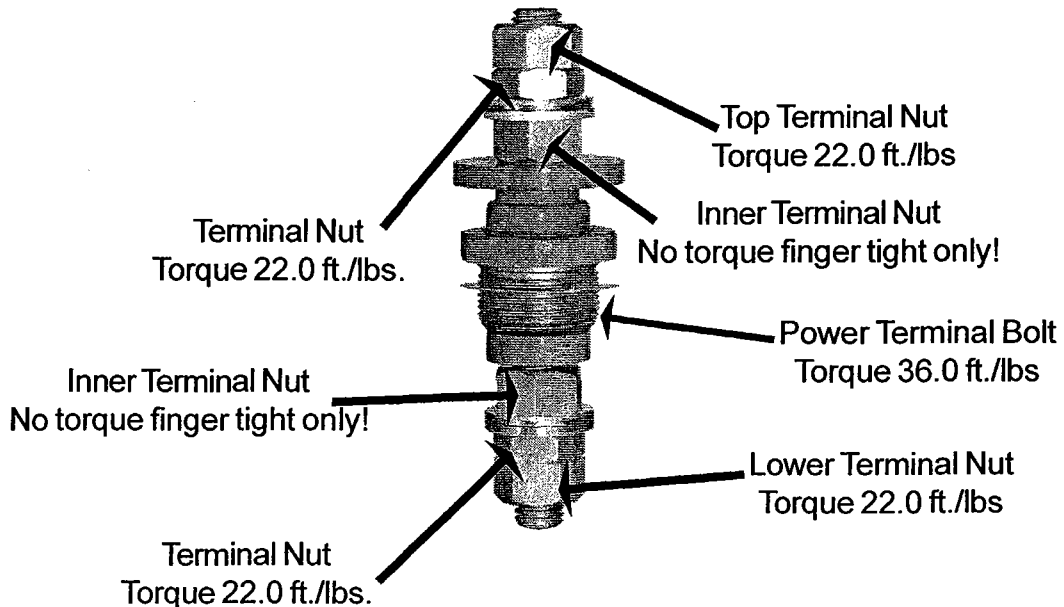

KITS AVAILABLE THROUGH ACCS

SLIPPER RING REPLACEMENT KIT

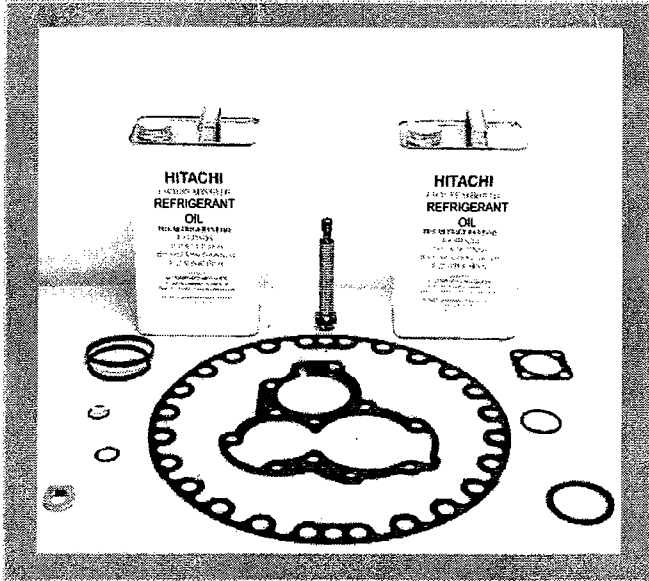

Kit Contains:

- 2 - Gallons of refrigerant oil
- 1 - Piston rod
- 1 - Slipper ring shaft
- 1 - Piston slipper ring
- 1 - Piston rod gasket
- 1 - Lock washer, piston rod
- 1 - Oil separator gasket
- 1 - Discharge casing end gasket
- 1 - Oil strainer cover gasket
- 1 - Oil strainer o-ring
- 1 - Discharge flange gasket
- 1 - Suction flange gasket
- 1 - Suction strainer gasket
- 1 - Oil test kit
- 1 - Procedure manual

ACCS slipper ring replacement kit has been assembled to assist in on site repair. This kit comes complete with all necessary replacement parts as well as a procedure manual. This preventive maintenance procedure will help to extend the life of the compressor and insure maximum capacity with continued efficient compressor performance.

OIL ANALYSIS TEST KIT

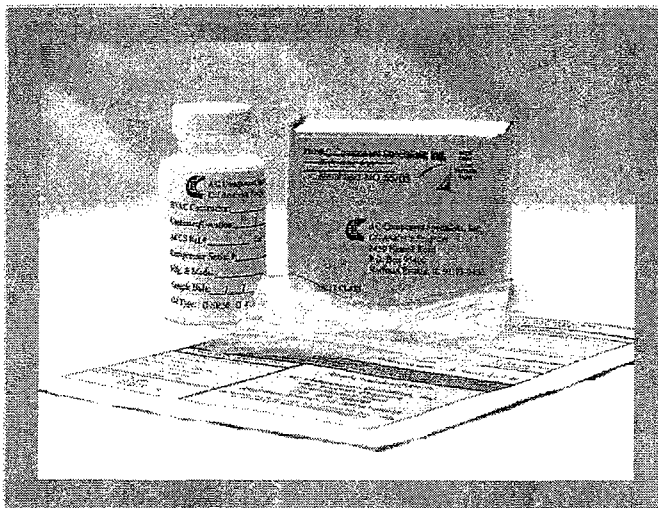

KIT CONTAINS:

- 1 - Oil Sample Bottle
- 1 - Sample Sealant Bag
- 1 - Addressed Return Box
- 1 - Oil Sample Data Sheet

The ACCS Oil Analysis Test Kit is an invaluable tool for preventive compressor maintenance. Using this kit on an annual basis will help maintain high performance levels from your HITACHI compressor. Test results will include

amount and type of contaminants in system as well as moisture content. Results of this test will help you make an informed discussion as to what type of maintenance is needed on compressor.

SERVICE PARTS LIST "005" SERIES

Bubble	DESCRIPTION	QTY	4005	5005	6005
1	Power Terminal Box Lid	1	TER1A04B	TER1A04B	TER1A04B
2	Power Terminal Box - Side Plate- Left	1	TER1A06A	TER1A06A	TER1A06A
3	Power Terminal Box	1	TER1A03B	TER1A03B	TER1A03B
4	Power Terminal Box Side Plate - Right	1	TER1A05A	TER1A05A	TER1A05A
5	Motor Terminal Plate Assembly	1	TPA1A01B	TPA1A01B	TPA1A01B
6	Gasket Terminal Plate Assembly	1	GSK1A04A	GSK1A04A	GSK1A04A
7	Gasket - Side Plate	1	GSK1A09B	GSK1A09B	GSK1A09B
8	Gasket Suction Flange	1	GSK1A02B	GSK1A02B	GSK1A02B
9	Suction Gas Strainer	1	STR1A02A	STR1A02A	STR1A02A
10	Gasket - Gas Strainer	1	GSK1A01B	GSK1A01B	GSK1A01B
11	Gasket - Motor Cover	1	GSK1A05B	GSK1A05B	GSK1A05B
12	Solenoid Valve	3	SOL1A01A	SOL1A01A	SOL1A01A
13	Gasket - Protector Terminal	1	GSK1A22B	GSK1A22B	GSK1A22B
14	Protector Terminal Plate Assembly	1	TPA1A02A	TPA1A02A	TPA1A02A
15	Gasket - Solenoid Valve	3	GSK1A17A	GSK1A17A	GSK1A17A
16	Unloader Piping	2	UNP1A01A	UNP1A01A	UNP1A01A
17	Oil Valve	1	VLV1A04A	VLV1A04A	VLV1A04A
18	Oil Strainer Cover with Valve Port	1	COV1A02A	COV1A02A	COV1A02A
19	Gasket - Oil Strainer Cover	1	GSK1A03B	GSK1A03B	GSK1A03B
20	Oil Strainer Assembly	1	STR1A01A	STR1A01A	STR1A01A
21	O'ring - Oil Strainer	1	ORG1A01A	ORG1A01A	ORG1A01A
22	Sight Glass Assembly	1	SGA1A01A	SGA1A01A	SGA1A01A
23	Gasket - Sight Glass	1	GSK1A13A	GSK1A13A	GSK1A13A
24	Crankcase Heater	1	CCH1Z01A	CCH1Z01A	CCH1Z01A
25	Gasket - Discharge Housing	1	GSK1A19B	GSK1A20B	GSK1A20B
26	Lockwasher - Bearing Assembly	2	LKW1A01A	LKW1A01A	LKW1A01A
27	Gasket - Sealed Flange	1	N/A	GSK1A10B	GSK1A10B
28	Gasket - Discharge Flange	1	GSK1A11B	GSK1A12B	GSK1A12B
29	Slipper Ring - Shaft	1	***	***	***
30	Gasket - Unloader Piston Assembly	1	***	***	***
31	Slipper Ring - Piston	1	***	***	***
32	Lock Washer - Unloader Assembly	1	***	***	***
33	Gasket - End Cover	1	***	***	***
34	Gasket - Oil Separator	1	GSK1A06B	GSK1A07B	GSK1A07B
35	Electronic Motor Protector Module	1	MOD1Z04A	MOD1Z04A	MOD1Z04A

*** Available only in Slipper-Ring Replacement Kit

HITACHI SCREW COMPRESSOR EXPLODED SERVICE PARTS VIEW

MODELS: 4005 SC-Z, 5005 SC-Z, & 6005 SC-Z

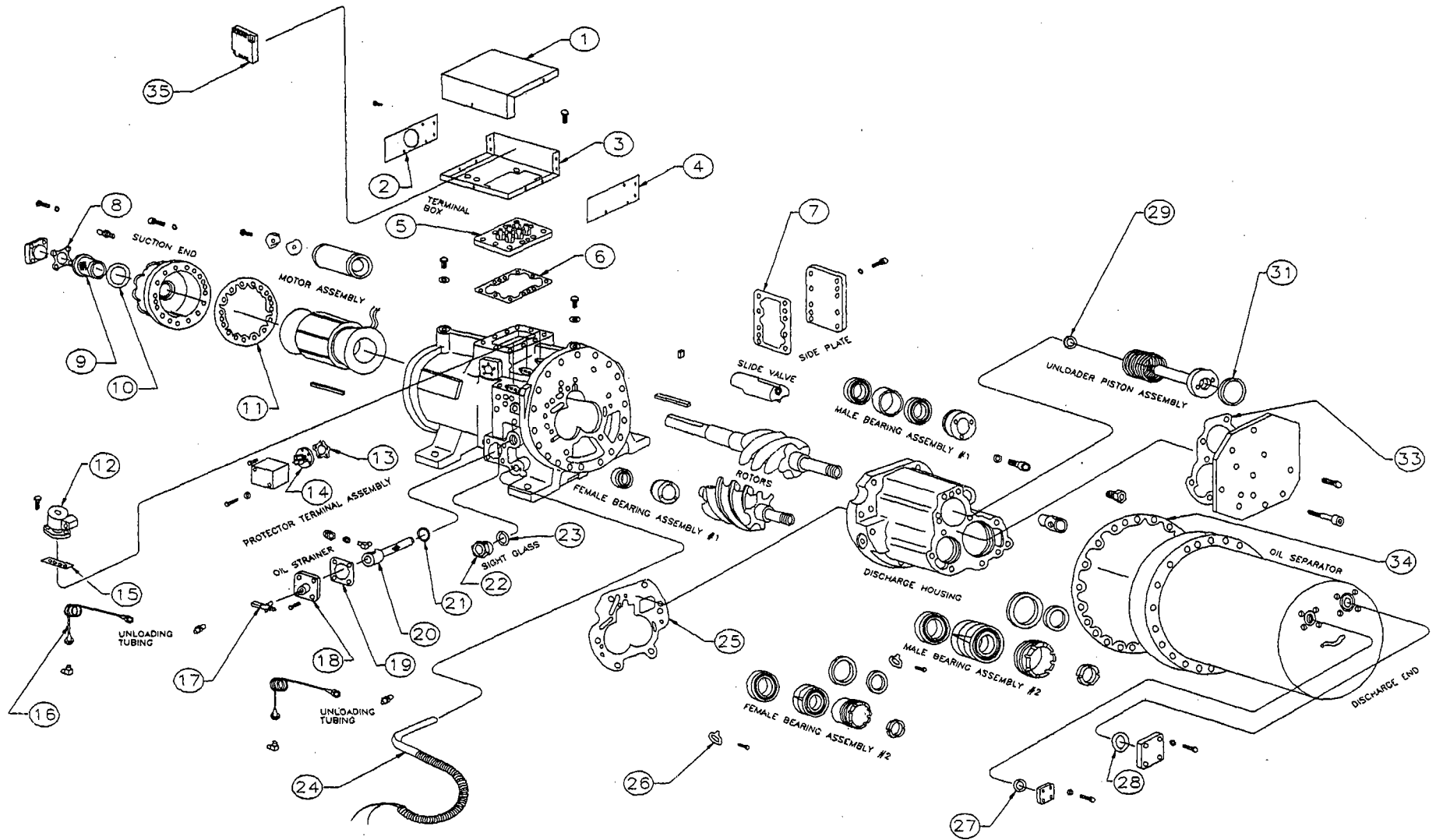

AC Component Specialists, Inc. • P.O. Box 500 • MARSHFIELD, MISSOURI 65706 • (417) 859-6067
 Authorized Nationwide HITACHI Screw Compressor and Replacement Parts Distributor
 ACCS SERVICE EXHIBIT NUMBER AC02003030033 © ACCS 2000

SERVICE PARTS LIST 10001SC-Z

Bubble #	Description	QTY.	10001SC-Z
1	POWER TERMINAL BOX LID	2	TER1A04B
2	POWER TERMINAL BOX - SIDE PLATE - LEFT	2	TER1A06A
3	POWER TERMINAL BOX	2	TER1A03B
4	POWER TERMINAL BOX SIDE PLATE - RIGHT	2	TER1A05A
5A	MOTOR TERMINAL PLATE ASSEMBLY	1	TPA1A03A
5B	MOTOR TERMINAL PLATE ASSEMBLY	1	TPA1A04A
6	MOTOR TERMINAL PLATE ASSEMBLY	2	GSK1A04A
7	GASKET SIDE PLATE ASSEMBLY	1	GSK1A09B
8	GASKET SUCTION FLANGE	1	GSK1A026A
9	SUCTION STRAINER	1	STR1A03A
10	GASKET - GAS STRAINER	1	GSK1A026A
11	GASKET - MOTOR COVER	1	GSK1A27A
12	SOLENOID VALVE	3	SOL1A01A
13	GASKET - PROTECTOR TERMINAL	1	GSK1A22B
14	PROTECTOR TERMINAL PLATE ASSEMBLY	1	TPA1A02A
15	GASKET - SOLENOID VALVE	6	GSK1A28A
16	UNLOADER PIPING	2	UNP1A01A
17	OIL VALVE	1	VLV1A04A
18	OIL STRAINER COVER W/VALVE PORT	1	COV1A02A
19	GASKET - OIL STRAINER COVER	1	GSK1A03B
20	OIL STRAINER ASSEMBLY	1	STR1A01A
21	O'RING-OIL STRAINER ASSEMBLY	1	ORG1A01A
22	SIGHT GLASS ASSEMBLY	1	SGA1A01A
23	GASKET - SIGHT GLASS	1	GSK1A13A
24	CRANKCASE HEATER	1	CCH1Z01A
25	GASKET - DISCHARGE HOUSING	1	GSK1A29A
26	LOCK WASHER - BEARING ASSEMBLY	2	LKW1A01A
27	GASKET SEALED FLANGE	1	GSK1A30A
28	GASKET - DISCHARGE FLANGE	1	GSK1A31A
29	SLIPPER RING - SHAFT	1	***
30	GASKET - UNLOADER PISTON ASSEMBLY	1	***
31	SLIPPER RING - PISTON	1	***
32	LOCK WASHER - UNLOADER ASSEMBLY	1	***
33	GASKET - END COVER	1	***
34	GASKET - OIL SEPARATOR	1	GSK1A34A
35	ELECTRONIC MOTOR PROTECTOR MODULE	1	MOD1Z04A
71	GASKET - BEARING COVER	1	GSK1A35A

***Available only in Slipper-Ring Replacement Kit

EXPLODED PARTS VIEW 10001SC-Z

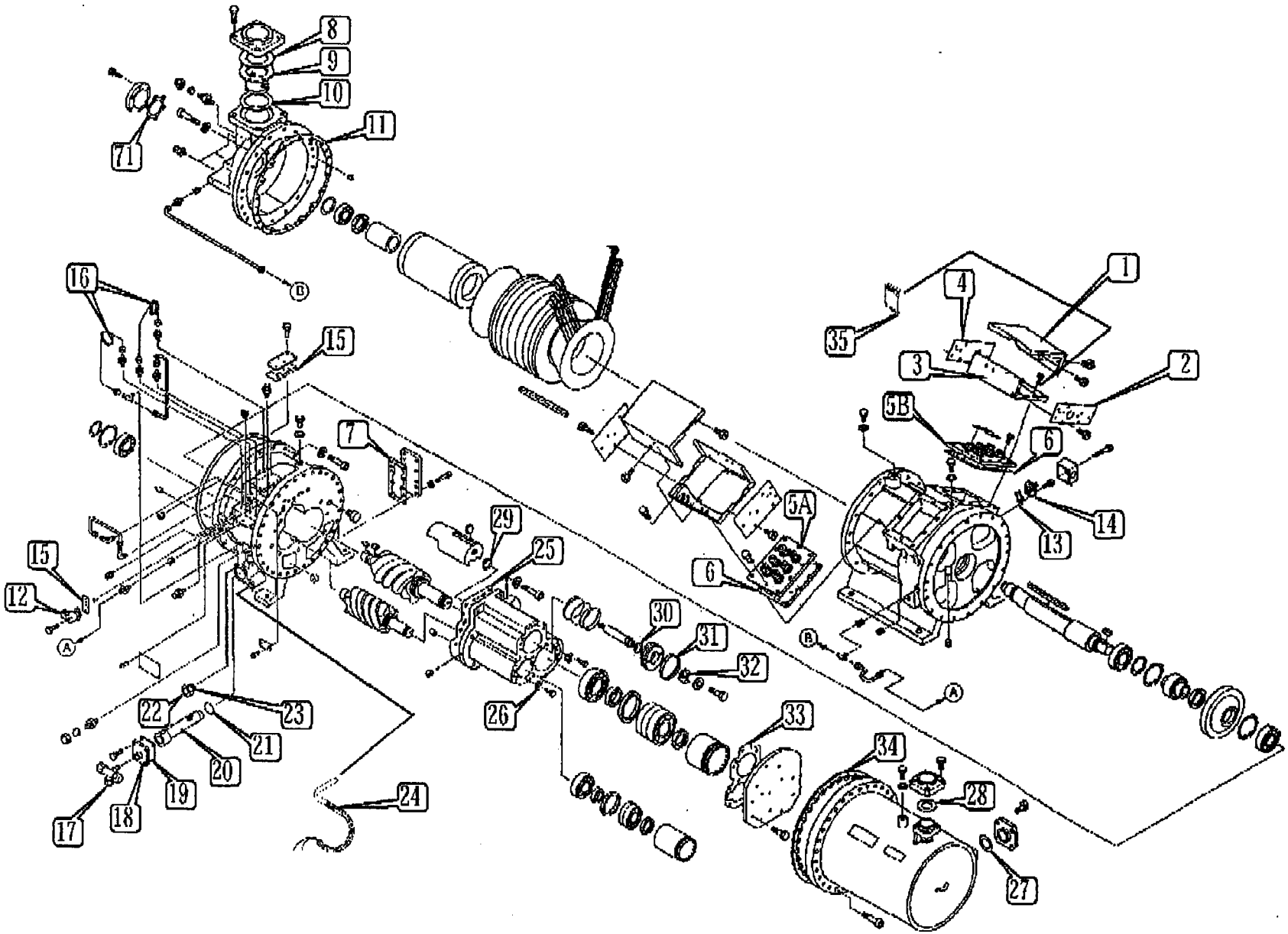



WARRANTY

A. AC COMPONENT SPECIALISTS, INC. (ACCS), warrants that new products sold by ACCS will be free from defects in material and workmanship, and will be delivered free from liens and encumbrances, with the term of said warranty being eighteen (18) months from the date of shipment or twelve (12) months from date of start-up, whichever occurs first for products; or

In case of spare parts and semiconductor components, sixty (60) days from the date of shipment to the customer, provided that:

1. ACCS is promptly notified (within the warranty period) of any warranty claim; and
2. Customer provides ACCS with the means and access to examine and test the products within a reasonable period of time, and at the customer's cost; and
3. ACCS's examination of such items shall disclose to its reasonable satisfaction that the claimed defect in the products constitutes a breach of the above warranty and was not caused by such occurrences as misuse, abuse, neglect, improper handling, installation, operation, maintenance, unauthorized repair, alteration or accident. Modifications of products by the customer, or at the customer's direction, unless specifically authorized in writing by ACCS, shall invalidate the warranty.

B. ACCS's liability under this warranty is limited to providing necessary replacement parts to the customer, repairing or replacing product, or issuing a credit in the amount of the product agreement price, at its election, for any such claim. The provision of replacements parts, or the repair or replacement of the product will not extend the warranty period. If ACCS elects to replace a defective part, ACCS' obligation is limited to making a replacement part available to the customer, FOB ACCS, and does not include such items as:

1. The provision of any labor involved or connected therewith, such as that which is required to diagnose trouble, service faults, etc., or removing or installing product or part; and
2. Responsibility for any transportation expense other than delivery FOB point; and
3. Any taxes duties or the like connection therewith.

THIS WARRANTY CONSTITUTES THE CUSTOMER'S SOLE REMEDY. THIS WARRANTY IS GIVEN IN LIEU OF ALL OTHER WARRANTIES, EXPRESS OR IMPLIED, INCLUDING IMPLIED WARRANTIES OF MERCHANTABILITY AND FITNESS FOR A PARTICULAR PURPOSE. THIS WARRANTY IS EXTENDED TO ACCS'S CUSTOMER ONLY AND IS NOT TRANSFERABLE TO SUBSEQUENT PURCHASERS OR USERS OF GOODS AND MERCHANDISE.

Compressor Information Guide

Please fill in the following information about your new HITACHI compressor. This information can be used as a quick reference when calling for service or technical information.

Compressor Model: _____
Compressor Voltage: _____
Compressor Serial #: _____

Date Compressor Purchased: _____
Compressor purchased through: _____

Date of compressor installation: _____

Technician or group that performed installation: _____

Oil type: _____

Refrigerant type: _____

Oil history information:

Date:	Type of Oil	Amount of oil added	Oil change out?	Oil Analysis Test?	Date:	Type of Oil	Amount of oil added	Oil change out?	Oil Analysis Test?
			yes/no	yes/no				yes/no	yes/no
			yes/no	yes/no				yes/no	yes/no
			yes/no	yes/no				yes/no	yes/no
			yes/no	yes/no				yes/no	yes/no
			yes/no	yes/no				yes/no	yes/no
			yes/no	yes/no				yes/no	yes/no
			yes/no	yes/no				yes/no	yes/no
			yes/no	yes/no				yes/no	yes/no
			yes/no	yes/no				yes/no	yes/no

Maintenance History

Date	Maintenance Performed

Notes



AC 02 008 07 0086

©2002 May

Suggested Retail Price \$15.00

AC Component Specialists, Inc.

899 South Prairie Lane

P.O. Box 500

Marshfield, Missouri 65706

Phone: (417) 859-6067

Fax: (417) 859-2109