



Air Conditioners

# Technical Data

Wall Mounted Unit



[www.daikin.eu](http://www.daikin.eu)

RX-JV/GV



Air Conditioners

# Technical Data

Wall Mounted Unit



[www.daikin.eu](http://www.daikin.eu)

RX-JV/GV

# TABLE OF CONTENTS

## RX-JV/GV

1	Features .....	2
2	Specifications .....	3
	Nominal Capacity and Nominal Input .....	3
	Technical Specifications .....	4
	Electrical Specifications .....	6
3	Electrical data.....	7
4	Capacity tables .....	8
	Cooling/Heating capacity tables .....	8
5	Dimensional drawing & centre of gravity .....	14
	Dimensional drawing .....	14
	Centre of gravity .....	16
6	Piping diagram.....	18
7	Wiring diagram.....	20
	Wiring diagram .....	20
8	Sound data.....	24
	Sound pressure spectrum .....	24
9	Operation range .....	27

# 1 Features

- Outdoor units for pair application
- Daikin outdoor units are neat and sturdy and can be mounted easily on a roof or terrace or simply placed against an outside wall.
- Outdoor units are fitted with a swing compressor, renowned for its low noise and high energy efficiency
- “Silent” buttons on the remote control lower the operation sound of the outdoor unit by 3dBA.
- Inverter compressors continuously adjust compressor speed to actual demand, fewer power - consuming starts and stops result in decreased energy consumption (up tot 30%) and more stable temperatures.



## 2 Specifications

2-1 Nominal Capacity and Nominal Input				RX20JV1B	RX25JV1B	RX35JV1B
For combination indoor units + outdoor units	Indoor Units			FTX20JV1B	FTX25JV1B	FTX35JV1B
Cooling capacity	Minimum	kW		1.3		
		Btu/h		4,400		
		Kcal/h		1,120		
	Standard	kW		2.0	2.5	3.3
		Btu/h		6,800	8,500	11,300
		Kcal/h		1,720	2,150	2,840
	Maximum	kW		2.6	3.0	3.8
		Btu/h		8,900	10,200	13,000
		Kcal/h		2,240	2,580	3,270
Heating capacity	Minimum	kW		1.3		
		Btu/h		4,400		
		Kcal/h		1,120		
	Standard	kW		2.5	2.8	3.5
		Btu/h		8,500	9,600	11,900
		Kcal/h		2,150	2,410	3,010
	Maximum	kW		3.5	4.0	4.8
		Btu/h		11,600	13,600	16,400
		Kcal/h		3,010	3,440	4,130
Piping connections	Drain	OD	mm	18.0		
	Gas	OD	mm	9.52		
	Heat insulation			Both liquid and gas pipes		
	Liquid	OD	mm	6.35		
Power Input	Cooling	Nominal	kW	0.550	0.730	0.980
	Heating	Nominal	kW	0.950	0.690	0.930
For combination indoor units + outdoor units	EER	Nominal		3.64	3.42	3.37
	COP	Nominal		4.24	4.06	3.76
	Energy Label	Cooling		A		
		Heating		A		
Annual energy consumption			kWh	275	365	490

2-1 Nominal Capacity and Nominal Input				RX50G2V1B	RX60G2V1B	RX71GV1B
For combination indoor units + outdoor units	Indoor Units			FTX50GV1B	FTX60GV1B	FTX71GV1B
Cooling capacity	Max.	Btu/h		20,500	22,900	29,000
		kcal/h		5,160	5,760	7,310
		kW		6.0	6.7	8.5
	Min.	Btu/h		5,800		7,800
		kcal/h		1,460		1,980
		kW		1.7		2.3
	Nom.	Btu/h		17,100	20,500	24,200
		kcal/h		4,300	5,160	6,110
		kW		5.0	6.0	7.1
Heating capacity	Max.	Btu/h		26,300	27,300	34,800
		kcal/h		6,620	6,880	8,770
		kW		7.7	8.0	10.2
	Min.	Btu/h		5,800		7,800
		kcal/h		1,460		1,980
		kW		1.7		2.3
	Nom.	Btu/h		19,800	23,900	28,000
		kcal/h		4,990	6,020	7,050
		kW		5.8	7.0	8.2

## 2 Specifications

2-1 Nominal Capacity and Nominal Input				RX50G2V1B	RX60G2V1B	RX71G1V1B
Power Input	Cooling	Max.	kW	2.08	2.40	3.20
		Min.	kW	0.44		
		Nom.	kW	1.55	1.99	2.35
	Heating	Max.	kW	2.53	2.81	3.82
		Min.	kW	0.40		
		Nom.	kW	1.60	2.04	2.55
For combination indoor units + outdoor units	EER	Nominal		3.23	3.02	
	COP	Nominal		3.63	3.43	3.22
	Energy Label	Cooling		A	B	B
		Heating		A	B	C
	Annual energy consumption		kWh	3000	3350	4250

2-2 Technical Specifications				RX20JV1B	RX25JV1B	RX35JV1B
Casing	Colour			Ivory White		
Dimensions	Unit	Height	mm	550		
		Width	mm	658		
		Depth	mm	275		
	Packing	Height	mm	616		
		Width	mm	788		
		Depth	mm	359		
Weight	Unit		kg	28	28	30
	Packed Unit		kg	31	31	34
Heat Exchanger	Dimensions	Length	mm	670	670	647
		Nr of Rows		1	1	2
		Fin Pitch	mm	1.4	1.4	1.4
		Nr of Stages		24	24	24
	Tube type		Hi-Xa(7)			
	Fin	Type		Waffle fin		
Fan	Type		Propeller			
	Quantity		1	1	1	
	Air Flow Rate	Cooling (High)	m³/min	29.2	29.2	27.6
		Heating (High)	m³/min	26.2	26.2	24.5
		Cooling (High)	cfm	1,030	1,030	975
		Heating (High)	cfm	927	927	865
	Motor	Quantity		1	1	1
Model		KFD-280-33-8A				
Motor	Speed (nominal)	Cooling (Low)	rpm	720	720	720
		Cooling (High)	rpm	860	860	860
		Heating (Low)	rpm	350	350	350
		Heating (High)	rpm	860	860	860
Fan	Motor	Output	W	33	33	33
	Motor	Model		KFD-280-33-8A		
	Type		Propeller			
Compressor	Quantity		1	1	1	
	Motor	Model		1YC23AEXDA		
		Type		Hermetically sealed swing compressor		
	Motor Output	W	750	750	750	
Operation Range	Cooling	Min	°CDB	10	10	10
		Max	°CDB	46	46	46
	Heating	Min	°CWB	-15	-15	-15
		Max	°CWB	20	20	20
Sound Level (nominal)	Cooling	Sound Power	dBA	60	60	62
		Sound Pressure (High)	dBA	46	46	48
	Heating	Sound Pressure (High)	dBA	47	47	48
Refrigerant	Type		R-410A			
	Charge		kg	0.74	0.74	1.0

## 2 Specifications

2-2 Technical Specifications				RX20JV1B	RX25JV1B	RX35JV1B
Refrigerant Oil	Type			FVC50K		
	Charged Volume		l	0.375	0.375	0.375
Piping connections	Liquid (OD)	Quantity		1	1	1
		Diameter (OD)	mm	6.35	6.35	6.35
	Gas	Quantity		1	1	1
		Diameter (OD)	mm	9.52	9.52	9.52
	Drain	Quantity		1	1	1
		Diameter (OD)	mm	18	18	18
	Piping Length	Maximum	m	15	15	15
	Additional Refrigerant Charge		kg/m	0.02(>10m)		
Installation height difference	Maximum	m	12	12	12	
Heat Insulation				Both liquid and gas pipes		
Standard Accessories	Item			Installation manual		
	Quantity			1	1	1
	Item			Drain plug		
	Quantity			1	1	1
Notes				Nominal cooling capacities are based on: indoor temperature: 27°CDB, 19.0°CWB; outdoor temperature: 35°CDB, 24°CWB, refr.pip.length: 5m		
				Nominal heating capacities are based on: indoor temperature: 20°CDB; outdoor temperature: 7°CDB, 6°CWB, refr.pip.length: 5m	Nominal heating capacities are based on: indoor temperature: 20°CDB, outdoor temperature: 7°CDB, 6°CWB, refr.pip. length 5m	Nominal heating capacities are based on: indoor temperature: 20°CDB; outdoor temperature: 7°CDB, 6°CWB, refr.pip.length: 5m

2-2 Technical Specifications				RX50G2V1B	RX60G2V1B	RX71GV1B
Casing	Colour			Ivory white		
Dimensions	Unit	Height	mm	792		900
		Width	mm	960		925
		Depth	mm	390		
	Packing	Height	mm	735		770
		Width	mm	825		900
		Depth	mm	300		320
Weight	Unit		kg	48		71
	Packed Unit		kg	53		79
Heat Exchanger	Dimensions	Length	mm	845		857
		Nr of Rows		2		
		Fin Pitch	mm	1.8		1.4
		Nr of Stages		32		
	Tube type		ø8 Hi-XA			
	Fin	Type		Waffle fin		
Treatment		Anti-corrosion treatment (PE)				
Fan	Type			Propeller		
	Air Flow Rate	Cooling (High)	m³/min	48.9	50.9	54.5
		Cooling (Low)	m³/min	41.7	42.4	46
		Cooling (High)	cfm	1,727	1,797	1,924
		Cooling (Low)	cfm	1,472	1,497	1,624
		Heating (High)	m³/min	45	46.3	46
		Heating (Low)	m³/min	41.7	42.4	46
		Heating (High)	cfm	1,589	1,635	1,624
		Heating (Low)	cfm	1,472	1,497	1,624
Motor	Model		KFD-380-50-8C			
Motor	Speed (nominal)	Cooling (Low)	rpm	670	680	730
		Cooling (High)	rpm	780	810	860
		Heating (Low)	rpm	670	680	730
		Heating (High)	rpm	720	740	730
Fan	Motor	Output	W	53		66

## 2 Specifications

2-2 Technical Specifications				RX50G2V1B	RX60G2V1B	RX71GV1B
Compressor	Motor	Model		2YC36BXD#C		2YC63BXD#A
		Type		Hermetically sealed swing compressor		
		Motor Output	W	1,20	1,10	1,92
Operation Range	Cooling	Min	°CDB	-10		
		Max	°CDB	46		
	Heating	Min	°CWB	-15		
		Max	°CWB	18		
Sound Level (nominal)	Cooling	Sound Power	dBa	61	63	66
		Sound Pressure (High)	dBa	47	49	52
		Sound Pressure (Low)	dBa	44	46	49
	Heating	Sound Pressure (High)	dBa	48	49	52
		Sound Pressure (Low)	dBa	45	46	49
Refrigerant	Type		R-410A			
	Charge	kg	1.5			
Refrigerant Oil	Type		FVC50K			
	Charged Volume	l	0.650		0.750	
Piping connections	Drain	OD	mm	18		
	Gas	OD	mm	12.7		15.9
	Liquid	OD	mm	6.35		
	Piping Length	Maximum	m	30		
		Chargeless	m	10		
	Additional Refrigerant Charge	kg/m	0.020 (for piping length exceeding 10m)			
Heat Insulation	Both liquid and gas pipes					
Standard Accessories	Drain socket					
	1					
	Installation manual					
	1					
Notes	Cooling: indoor temp. 27°CDB, 19.0°CWB; outdoor temp. 35°CDB, 24°CWB; equivalent piping length: 5m					
	Heating: indoor temp. 20°CDB; outdoor temp. 7°CDB, 6°CWB; equivalent refrigerant piping: 5m					
	SL: The silent fan level of the air flow rate setting					
	220V;3;230V;4;240V					

2-3 Electrical Specifications				RX20JV1B	RX25JV1B	RX35JV1B
Power Supply	Name		V1			
	Phase		1~			
	Frequency	Hz	50	50	50	
	Voltage	V	220-230-240			
Current	Nominal running current (RLA)	Cooling (A)	A	2.52	3.52	5.02
		Heating (A)	A	2.62	3.02	4.52
	Starting current (cooling/heating)	A	2.7	3.7	5.0	
Wiring connections	For Power Supply	Quantity	3	3	3	
	For connection with indoor	Quantity	4	4	4	
	Remark	Earth wire included				

2-3 Electrical Specifications				RX50G2V1B	RX60G2V1B	RX71GV1B
Power Supply	Name		V1			
	Phase		1~			
	Frequency	Hz	50			
	Voltage	V	220-230-240			
Current	Nominal running current (RLA)	Cooling	A	7.040 - 6.750 - 6.450	9.010 - 8.920 - 8.230	10.590 - 10.200 - 9.710
		Heating	A	7.230 - 6.940 - 6.640	9.190 - 8.800 - 8.410	11.420 - 10.930 - 10.440
Wiring connections	For Power Supply	Quantity	3			
	For connection with indoor	Remark	Earth wire included			



### 3 Electrical data

#### RX20-35JV

Representative unit combination		Power supply				Comp		OFM		IFM	
Indoor unit	Outdoor unit	Hz-Volts	Voltage range	MCA	MFA	RHz	RLA	W	FLA	W	FLA
FTX20JV1B	RX20JV1B	50 - 220	Max. 50Hz 264V Min. 50Hz 198V	14.5	16	36	2.2	33	0.17	16	0.12
		50 - 230									
		50 - 240									
FTX25JV1B	RX25JV1B	50 - 220	Max. 50Hz 264V Min. 50Hz 198V	14.5	16	48	3.2	33	0.17	16	0.12
		50 - 230									
		50 - 240									
FTX35JV1B	RX35JV1B	50 - 220	Max. 50Hz 264V Min. 50Hz 198V	14.5	16	70	4.7	33	0.17	16	0.12
		50 - 230									
		50 - 240									

#### SYMBOLS

- MCA : Min. Circuit Amps (A)
- MFA : Max. Fuse Amps (A)
- RLA : Rated Load Amps (A)
- OFM : Outdoor Fan Motor
- IFM : Indoor Fan Motor
- FLA : Full Load Amps (A)
- W : Fan Motor Rated Output (W)
- RHz : Rated Operating Frequency (Hz)

#### NOTES

1. RLA is based on the following conditions.
  - Indoor temp. 27°C DB/19°C WB.
  - Outdoor temp. 35°C DB.
2. Maximum allowable voltage variation between phases is 2%.
3. Select wire size based on the larger value of MCA.
4. Instead of fuse, use circuit breaker.

3D065911

#### RX50-60G RX71GV

Representative unit combination		Power supply				Comp		OFM		IFM	
Indoor unit	Outdoor unit	Hz-Volts	Voltage range	MCA	MFA	RHz	RLA	W	FLA	W	FLA
FTX71GV1B	RX71GV1B	50 - 220	Max. 50Hz 264V Min. 50Hz 198V	19.75	20.0	57	10.3	66	0.40	43	0.19
		50 - 230					9.9				
		50 - 240					9.4				
FTX50GV1B	RX50G2V1B	50 - 220	Max. 50Hz 264V Min. 50Hz 198V	19.75	20.0	67	6.7	53	0.27	43	0.16
		50 - 230					6.4				
		50 - 240					6.1				
FTX60GV1B	RX60G2V1B	50 - 220	Max. 50Hz 264V Min. 50Hz 198V	19.75	20.0	84	8.7	53	0.32	43	0.16
		50 - 230					8.3				
		50 - 240					7.9				

#### SYMBOLS

- MCA : Min. Circuit Amps (A)
- MFA : Max. Fuse Amps (A)
- RLA : Rated Load Amps (A)
- OFM : Outdoor Fan Motor
- IFM : Indoor Fan Motor
- FLA : Full Load Amps (A)
- W : Fan Motor Rated Output (W)
- RHz : Rated Operating frequency (Hz)

#### NOTES

1. RLA is based on the following conditions.
  - Indoor temp. 27°C DB/19.0°C WB.
  - Outdoor temp. 35°C DB.
2. Maximum allowable voltage variation between phases is 2%.
3. Select wire size based on the larger value of MCA.
4. Instead of fuse, use circuit breaker.

3D066565A

# 4 Capacity tables

## 4 - 1 Cooling/Heating capacity tables

FTX20JV1B+RX20JV1B

Cooling 50Hz 220-240V

AFR	9.1
BF	0.24

Indoor		Outdoor temperature (°C DB)																	
EWB	EDB	20			25			30			32			35			40		
°C	°C	TC	SHC	PI	TC	SHC	PI	TC	SHC	PI	TC	SHC	PI	TC	SHC	PI	TC	SHC	PI
14.0	20	2.05	1.71	0.42	1.96	1.67	0.46	1.86	1.62	0.50	1.83	1.61	0.52	1.77	1.58	0.54	1.68	1.54	0.58
16.0	22	2.14	1.68	0.42	2.05	1.64	0.47	1.95	1.60	0.51	1.92	1.59	0.52	1.86	1.56	0.55	1.77	1.52	0.59
18.0	25	2.23	1.79	0.43	2.14	1.75	0.47	2.05	1.71	0.51	2.01	1.70	0.52	1.95	1.68	0.55	1.86	1.64	0.59
19.0	27	2.28	1.91	0.43	2.19	1.88	0.47	2.09	1.84	0.51	2.06	1.83	0.53	2.00	1.80	0.55	1.91	1.77	0.59
22.0	30	2.42	1.85	0.43	2.32	1.82	0.47	2.23	1.79	0.51	2.19	1.78	0.53	2.14	1.76	0.55	2.05	1.73	0.59
24.0	32	2.51	1.81	0.43	2.42	1.78	0.47	2.32	1.76	0.52	2.29	1.74	0.53	2.23	1.73	0.56	2.14	1.70	0.60

Heating 50Hz 220-240V

AFR	9.4
-----	-----

Indoor		Outdoor temperature (°C WB)									
EDB		-10		-5		0		6		10	
°C		TC	PI	TC	PI	TC	PI	TC	PI	TC	PI
15.0		1.68	0.50	1.97	0.52	2.25	0.55	2.59	0.58	2.81	0.60
20.0		1.60	0.51	1.88	0.54	2.16	0.56	2.50	0.59	2.73	0.61
22.0		1.56	0.52	1.84	0.54	2.13	0.57	2.47	0.60	2.69	0.61
24.0		1.53	0.52	1.81	0.55	2.09	0.57	2.43	0.60	2.66	0.62
25.0		1.51	0.53	1.79	0.55	2.07	0.57	2.41	0.60	2.64	0.62
27.0		1.48	0.53	1.76	0.56	2.04	0.58	2.38	0.61	2.61	0.63

### SYMBOLS

AFR : Air flow rate (m<sup>3</sup>/min.)  
 BF : Bypass factor  
 EWB : Entering wet bulb temp. (°C)  
 EDB : Entering dry bulb temp. (°C)  
 TC : Total capacity (kW)  
 SHC : Sensible heat capacity (kW)  
 PI : Power input (kW)

### NOTES

- Capacities are based on the following conditions.  
 (1) Corresponding refrigerant piping length : 5m  
 (2) Level difference : 0m
- shows nominal (rated) capacities and power input

3D065912

# 4 Capacity tables

## 4 - 1 Cooling/Heating capacity tables

FTX25JV1B+RX25JV1B

Cooling 50Hz 220-240V

AFR	9.2
BF	0.29

Indoor		Outdoor temperature (°CDB)																	
EWB	EDB	20			25			30			32			35			40		
°C	°C	TC	SHC	PI	TC	SHC	PI	TC	SHC	PI	TC	SHC	PI	TC	SHC	PI	TC	SHC	PI
14.0	20	2.15	1.72	0.52	2.15	1.72	0.58	2.15	1.72	0.65	2.15	1.72	0.68	2.15	1.72	0.72	2.10	1.69	0.78
16.0	22	2.68	1.89	0.56	2.56	1.83	0.62	2.44	1.78	0.67	2.40	1.76	0.69	2.33	1.72	0.73	2.21	1.67	0.78
18.0	25	2.79	1.98	0.57	2.68	1.93	0.62	2.56	1.88	0.67	2.51	1.86	0.70	2.44	1.83	0.73	2.33	1.78	0.78
19.0	27	2.85	2.09	0.57	2.73	2.04	0.62	2.62	1.99	0.68	2.57	1.97	0.70	2.50	1.94	0.73	2.38	1.90	0.78
22.0	30	3.02	2.02	0.57	2.91	1.97	0.63	2.79	1.93	0.68	2.74	1.91	0.70	2.67	1.89	0.73	2.56	1.85	0.79
24.0	32	3.14	1.96	0.58	3.02	1.92	0.63	2.90	1.89	0.68	2.86	1.87	0.71	2.79	1.85	0.74	2.67	1.81	0.79

Heating 50Hz 220-240V

AFR	9.7
-----	-----

Indoor		Outdoor temperature (°CWB)									
EDB		-10		-5		0		6		10	
°C		TC	PI	TC	PI	TC	PI	TC	PI	TC	PI
15.0		1.88	0.58	2.20	0.61	2.52	0.64	2.90	0.67	3.15	0.70
20.0		1.79	0.60	2.10	0.63	2.42	0.66	2.80	0.69	3.05	0.71
22.0		1.75	0.61	2.07	0.63	2.38	0.66	2.76	0.70	3.01	0.72
24.0		1.71	0.61	2.03	0.64	2.34	0.67	2.72	0.70	2.98	0.73
25.0		1.69	0.61	2.01	0.64	2.32	0.67	2.70	0.71	2.96	0.73
27.0		1.65	0.62	1.97	0.65	2.29	0.68	2.66	0.71	2.92	0.73

**SYMBOLS**

- AFR : Air flow rate (m<sup>3</sup>/min.)
- BF : Bypass factor
- EWB : Entering wet bulb temp. (°C)
- EDB : Entering dry bulb temp. (°C)
- TC : Total capacity (kW)
- SHC : Sensible heat capacity (kW)
- PI : Power input (kW)

**NOTES**

1. Capacities are based on the following conditions.
  - (1) Corresponding refrigerant piping length : 5m
  - (2) Level difference : 0m
2.  show nominal (rated) capacities and power input

3D065914

# 4 Capacity tables

## 4 - 1 Cooling/Heating capacity tables

FTX35JV1B+RX35JV1B

Cooling 50Hz 220-240V

AFR	9.3
BF	0.25

Indoor		Outdoor temperature (°CDB)																	
EWB	EDB	20			25			30			32			35			40		
°C	°C	TC	SHC	PI	TC	SHC	PI	TC	SHC	PI	TC	SHC	PI	TC	SHC	PI	TC	SHC	PI
14.0	20	2.30	1.83	0.72	2.30	1.83	0.82	2.30	1.83	0.90	2.30	1.83	0.93	2.30	1.83	0.97	2.30	1.83	1.04
16.0	22	3.07	2.11	0.75	3.07	2.11	0.83	3.07	2.11	0.90	3.07	2.11	0.93	3.07	2.11	0.97	2.92	2.04	1.05
18.0	25	3.68	2.43	0.76	3.53	2.36	0.83	3.38	2.29	0.91	3.32	2.26	0.93	3.22	2.22	0.98	3.07	2.15	1.05
19.0	27	3.76	2.54	0.76	3.61	2.48	0.84	3.45	2.41	0.91	3.39	2.38	0.94	3.30	2.34	0.98	3.15	2.27	1.05
22.0	30	3.99	2.45	0.77	3.84	2.39	0.84	3.68	2.32	0.91	3.62	2.30	0.94	3.53	2.27	0.99	3.37	2.21	1.06
24.0	32	4.14	2.38	0.77	3.99	2.32	0.85	3.83	2.26	0.92	3.77	2.24	0.95	3.68	2.21	0.99	3.53	2.16	1.06

Heating 50Hz 220-240V

AFR	10.1
-----	------

Indoor		Outdoor temperature (°CWB)									
EDB		-10		-5		0		6		10	
°C		TC	PI	TC	PI	TC	PI	TC	PI	TC	PI
15.0		2.36	0.79	2.75	0.82	3.15	0.86	3.62	0.91	3.94	0.94
20.0		2.24	0.81	2.63	0.85	3.03	0.88	3.50	0.93	3.82	0.96
22.0		2.19	0.82	2.58	0.85	2.98	0.89	3.45	0.94	3.77	0.97
24.0		2.14	0.82	2.53	0.86	2.93	0.90	3.40	0.95	3.72	0.98
25.0		2.11	0.83	2.51	0.87	2.90	0.90	3.38	0.95	3.70	0.98
27.0		2.07	0.84	2.46	0.88	2.86	0.91	3.33	0.96	3.65	0.99

### SYMBOLS

AFR : Air flow rate (m<sup>3</sup>/min.)  
 BF : Bypass factor  
 EWB : Entering wet bulb temp. (°C)  
 EDB : Entering dry bulb temp. (°C)  
 TC : Total capacity (kW)  
 SHC : Sensible heat capacity (kW)  
 PI : Power input (kW)

### NOTES

- Capacities are based on the following conditions.  
 (1) Corresponding refrigerant piping length : 5m  
 (2) Level difference : 0m
- shows nominal (rated) capacities and power input.

# 4 Capacity tables

## 4 - 1 Cooling/Heating capacity tables

FTX50GV1B+RX50G2V1B

Cooling 50Hz 220-240V

AFR	14.7
BF	0.28

Indoor		Outdoor temperature (°C DB)																	
EWB	EDB	20			25			30			32			35			40		
°C	°C	TC	SHC	PI	TC	SHC	PI	TC	SHC	PI	TC	SHC	PI	TC	SHC	PI	TC	SHC	PI
14.0	20	5.12	3.61	1.19	4.89	3.49	1.30	4.66	3.37	1.42	4.56	3.32	1.46	4.42	3.25	1.53	4.19	3.13	1.65
16.0	22	5.35	3.55	1.20	5.12	3.43	1.31	4.89	3.32	1.43	4.79	3.27	1.47	4.65	3.21	1.54	4.42	3.10	1.65
18.0	25	5.58	3.69	1.20	5.35	3.58	1.32	5.12	3.47	1.43	5.02	3.43	1.48	4.88	3.37	1.55	4.65	3.26	1.66
19.0	27	5.70	3.86	1.21	5.47	3.75	1.32	5.23	3.65	1.44	5.14	3.61	1.48	5.00	3.55	1.55	4.77	3.45	1.66
22.0	30	6.04	3.71	1.22	5.81	3.62	1.33	5.58	3.52	1.45	5.49	3.49	1.49	5.35	3.43	1.56	5.11	3.35	1.67
24.0	32	6.27	3.60	1.22	6.04	3.52	1.34	5.81	3.43	1.45	5.72	3.40	1.50	5.58	3.35	1.57	5.34	3.27	1.68

Heating 50Hz 220-240V

AFR	16.1
-----	------

Indoor		Outdoor temperature (°C WB)									
EDB		-10		-5		0		6		10	
°C	°C	TC	PI	TC	PI	TC	PI	TC	PI	TC	PI
15.0	3.90	1.35	4.56	1.42	5.21	1.48	6.00	1.56	6.52	1.62	
20.0	3.70	1.39	4.36	1.46	5.01	1.52	5.80	1.60	6.32	1.65	
22.0	3.62	1.40	4.28	1.47	4.93	1.54	5.72	1.61	6.24	1.67	
24.0	3.54	1.42	4.20	1.48	4.85	1.55	5.64	1.63	6.16	1.68	
25.0	3.50	1.43	4.16	1.49	4.81	1.56	5.60	1.64	6.12	1.69	
27.0	3.42	1.44	4.08	1.51	4.73	1.57	5.52	1.65	6.04	1.70	

### SYMBOLS

- AFR : Air flow rate (m<sup>3</sup>/min.)
- BF : Bypass factor
- EWB : Entering wet bulb temp. (°C)
- EDB : Entering dry bulb temp. (°C)
- TC : Total capacity (kW)
- SHC : Sensible heat capacity (kW)
- PI : Power input (kW)

### NOTES

1. Ratings shown are net capacities which include a deduction for indoor fan motor heat.
2.   shows nominal (rated) capacities and power input.
3. TC, PI and SHC must be calculated by interpolation using the figures in the above tables. (Figures out of the tables should not be used for calculation.)
4. About SHC which are not mentioned on the table, please calculate them with around values in direct proportion.
5. Capacities are based on the following conditions.  
Corresponding refrigerant piping length : 7.5m  
Level difference : 0m
6. Air flow rate (AFR) and Bypass factor (BF) are tabulated above table.

3D051923C

## 4 Capacity tables

### 4 - 1 Cooling/Heating capacity tables

#### FTX60GV1B+RX60G2V1B

Cooling 50Hz 220-240V

AFR	16.2
BF	0.29

Indoor		Outdoor temperature (°C DB)																	
EWB	EDB	20			25			30			32			35			40		
°C	°C	TC	SHC	PI	TC	SHC	PI	TC	SHC	PI	TC	SHC	PI	TC	SHC	PI	TC	SHC	PI
14.0	20	5.60	3.94	1.49	5.60	3.94	1.66	5.59	3.94	1.82	5.48	3.88	1.88	5.31	3.79	1.97	5.03	3.64	2.12
16.0	22	6.42	4.17	1.54	6.14	4.02	1.68	5.86	3.88	1.83	5.75	3.82	1.89	5.59	3.74	1.98	5.31	3.60	2.12
18.0	25	6.70	4.31	1.54	6.42	4.17	1.69	6.14	4.04	1.84	6.03	3.99	1.90	5.86	3.91	1.99	5.58	3.78	2.13
19.0	27	6.84	4.49	1.55	6.56	4.36	1.70	6.28	4.23	1.84	6.17	4.18	1.90	6.00	4.10	1.99	5.72	3.98	2.14
22.0	30	7.25	4.31	1.56	6.97	4.19	1.71	6.69	4.08	1.86	6.58	4.04	1.91	6.41	3.97	2.00	6.14	3.86	2.15
24.0	32	7.53	4.18	1.57	7.25	4.07	1.72	6.97	3.97	1.86	6.86	3.93	1.92	6.69	3.87	2.01	6.41	3.77	2.16

Heating 50Hz 220-240V

AFR	17.4
-----	------

Indoor		Outdoor temperature (°C WB)									
EDB		-10		-5		0		6		10	
°C	°C	TC	PI	TC	PI	TC	PI	TC	PI	TC	PI
15.0	4.71	1.73	5.50	1.81	6.29	1.89	7.24	1.99	7.87	2.06	
20.0	4.47	1.77	5.26	1.86	6.05	1.94	7.00	2.04	7.63	2.11	
22.0	4.37	1.79	5.16	1.87	5.95	1.96	6.90	2.06	7.54	2.13	
24.0	4.28	1.81	5.07	1.89	5.86	1.98	6.81	2.08	7.44	2.14	
25.0	4.23	1.82	5.02	1.90	5.81	1.99	6.76	2.09	7.39	2.15	
27.0	4.13	1.84	4.92	1.92	5.71	2.00	6.66	2.10	7.29	2.17	

#### SYMBOLS

AFR	: Air flow rate	(m <sup>3</sup> /min.)
BF	: Bypass factor	
EWB	: Entering wet bulb temp.	(°C)
EDB	: Entering dry bulb temp.	(°C)
TC	: Total capacity	(kW)
SHC	: Sensible heat capacity	(kW)
PI	: Power input	(kW)

#### NOTES

- Ratings shown are net capacities which include a deduction for indoor fan motor heat.
- shows nominal (rated) capacities and power input.
- TC, PI and SHC must be calculated by interpolation using the figures in the above tables. (Figures out of the tables should not be used for calculation.)
- About SHC which are not mentioned on the table, please calculate them with around values in direct proportion.
- Capacities are based on the following conditions.
  - Corresponding refrigerant piping length : 7.5m
  - Level difference : 0m
- Air flow rate (AFR) and Bypass factor (BF) are tabulated above table.

3D051924E

# 4 Capacity tables

## 4 - 1 Cooling/Heating capacity tables

FTX71GV1B+RX71GV1B

Cooling 50Hz 220-240V

AFR	17.4
BF	0.30

Indoor		Outdoor temperature (°C DB)																	
EWB	EDB	20			25			30			32			35			40		
°C	°C	TC	SHC	PI	TC	SHC	PI	TC	SHC	PI	TC	SHC	PI	TC	SHC	PI	TC	SHC	PI
14.0	20	5.93	4.18	1.64	5.93	4.18	1.86	5.93	4.18	2.07	5.93	4.18	2.16	5.93	4.18	2.29	5.93	4.18	2.50
16.0	22	7.28	4.67	1.78	7.27	4.66	1.99	6.94	4.48	2.16	6.81	4.41	2.23	6.61	4.31	2.33	6.28	4.14	2.51
18.0	25	7.93	4.98	1.82	7.60	4.81	2.00	7.27	4.65	2.17	7.13	4.58	2.24	6.94	4.48	2.34	6.61	4.33	2.52
19.0	27	8.09	5.16	1.83	7.76	5.00	2.00	7.43	4.84	2.18	7.30	4.78	2.25	7.10	4.69	2.35	6.77	4.53	2.52
22.0	30	8.58	4.95	1.84	8.25	4.81	2.02	7.92	4.67	2.19	7.79	4.61	2.26	7.59	4.53	2.37	7.26	4.39	2.54
24.0	32	8.91	4.79	1.85	8.58	4.66	2.03	8.25	4.53	2.20	8.12	4.48	2.27	7.92	4.40	2.38	7.59	4.28	2.55

Heating 50Hz 220-240V

AFR	19.7
-----	------

Indoor		Outdoor temperature (°C WB)									
EDB		-10		-5		0		6		10	
°C	°C	TC	PI	TC	PI	TC	PI	TC	PI	TC	PI
15.0		5.52	2.16	6.45	2.26	7.37	2.37	8.48	2.49	9.22	2.58
20.0		5.24	2.21	6.16	2.32	7.09	2.42	8.20	2.55	8.94	2.63
22.0		5.12	2.24	6.05	2.34	6.98	2.45	8.09	2.57	8.83	2.66
24.0		5.01	2.26	5.94	2.36	6.86	2.47	7.97	2.60	8.71	2.68
25.0		4.95	2.27	5.88	2.38	6.81	2.48	7.92	2.61	8.47	2.68
27.0		4.84	2.29	5.77	2.40	6.69	2.50	7.80	2.63	7.92	2.68

**SYMBOLS**

- AFR : Air flow rate (m<sup>3</sup>/min.)
- BF : Bypass factor
- EWB : Entering wet bulb temp. (°C)
- EDB : Entering dry bulb temp. (°C)
- TC : Total capacity (kW)
- SHC : Sensible heat capacity (kW)
- PI : Power input (kW)

**NOTES**

1. Capacities are based on the following conditions.  
 (1) Corresponding refrigerant piping length : 7.5m  
 (2) Level difference : 0m
2.  shows nominal (rated) capacities and power input.

# 5 Dimensional drawing & centre of gravity

## 5 - 1 Dimensional drawing

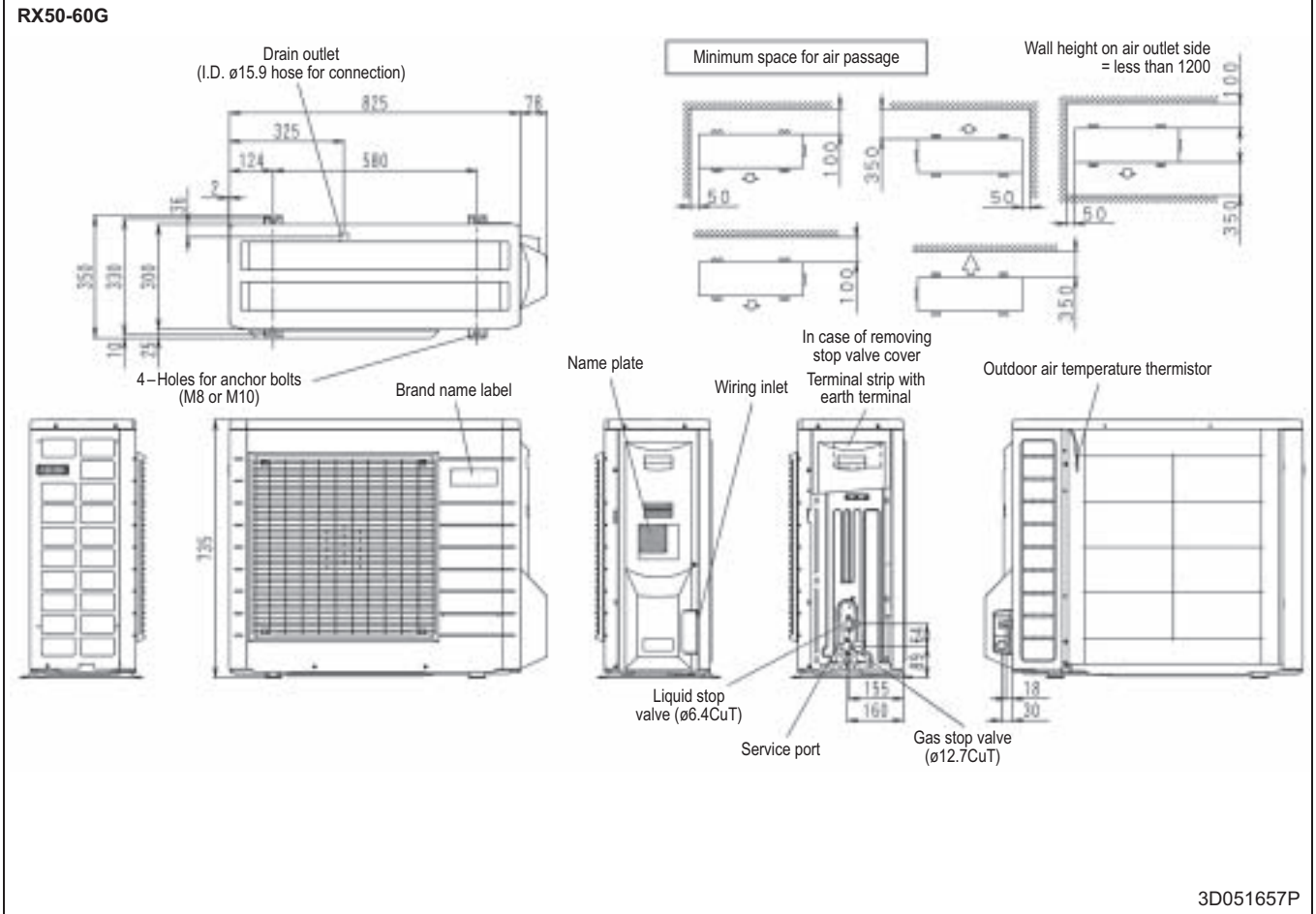
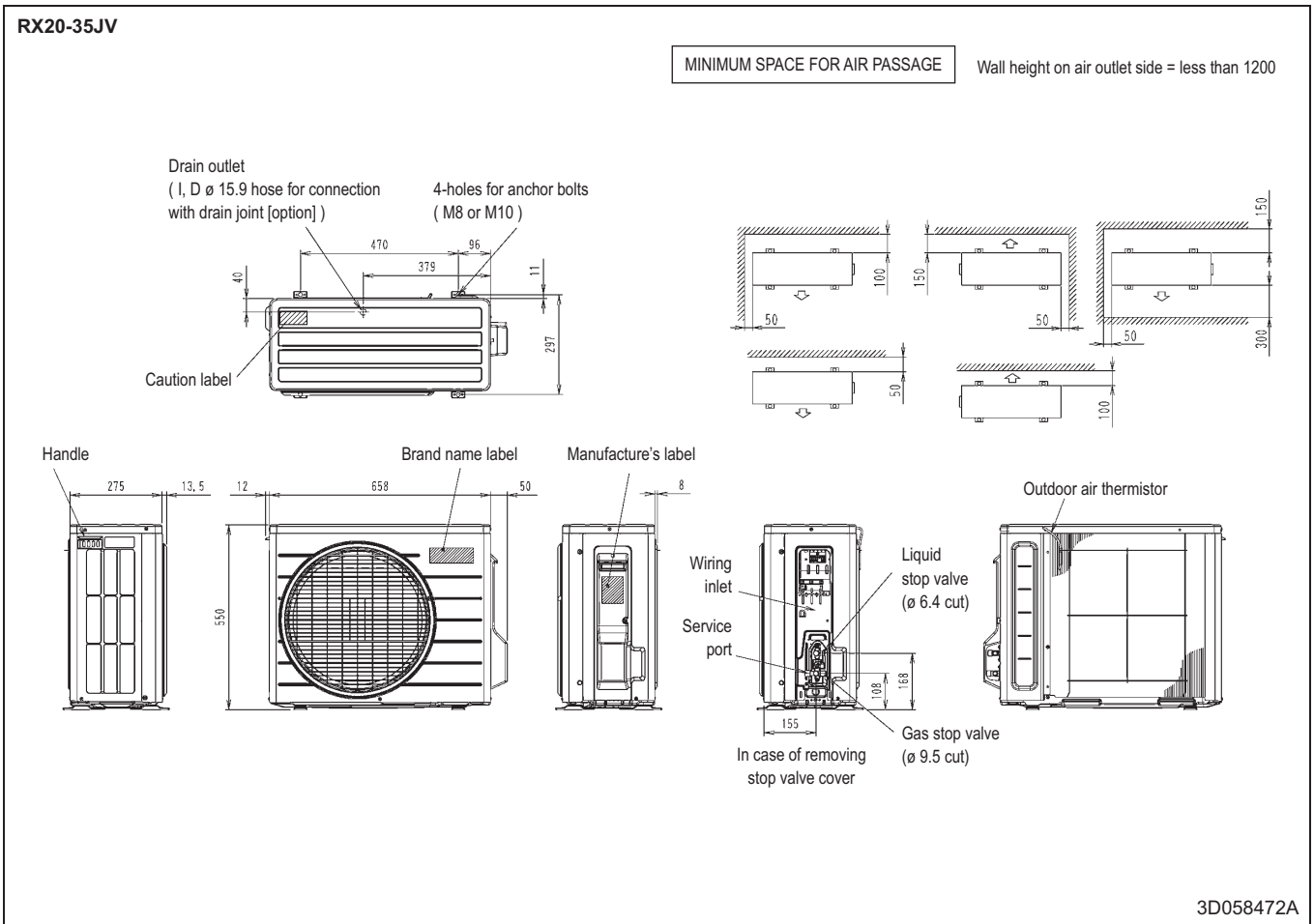



# 5 Dimensional drawing & centre of gravity

## 5 - 1 Dimensional drawing

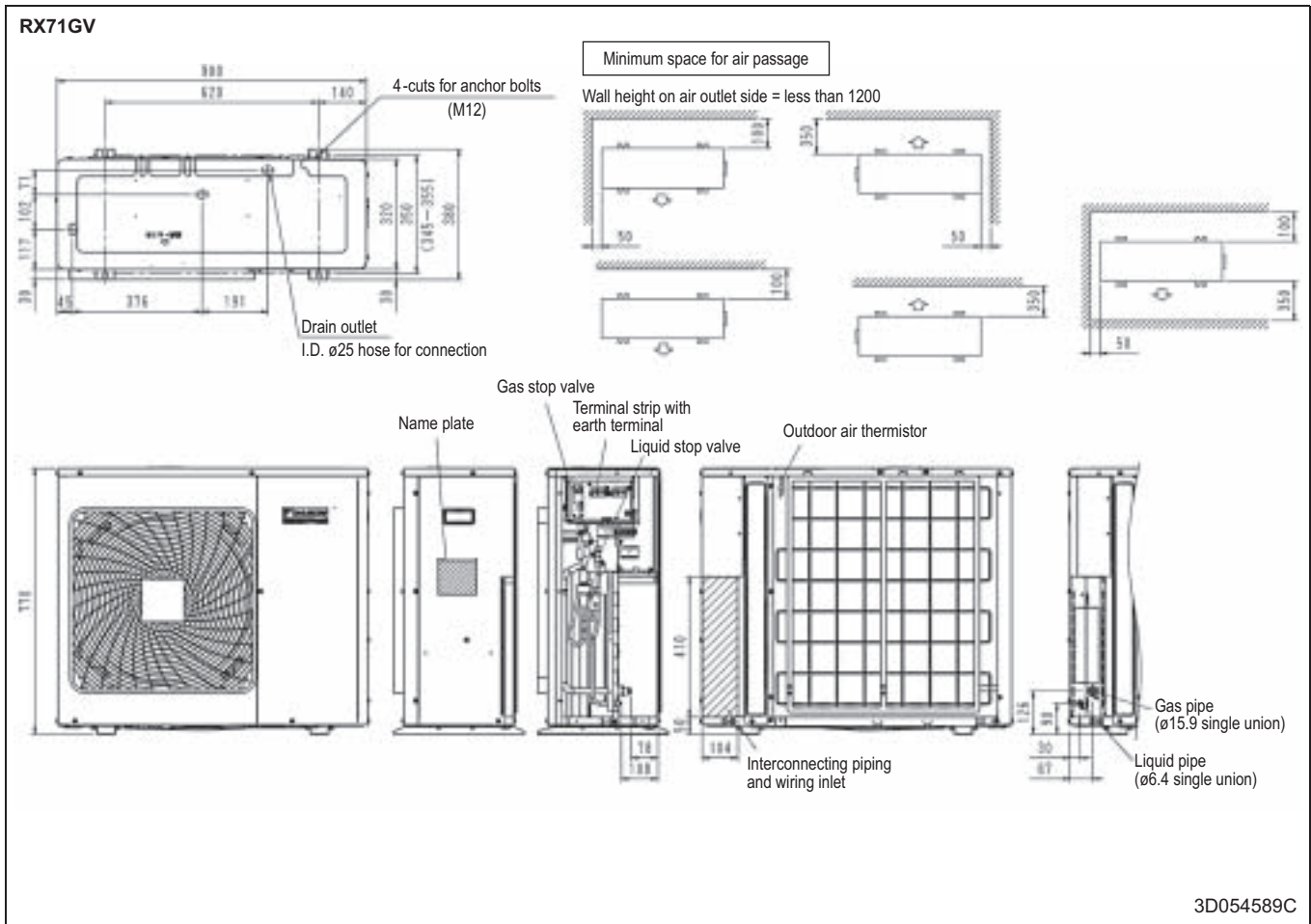

## 5 Dimensional drawing & centre of gravity

### 5 - 2 Centre of gravity

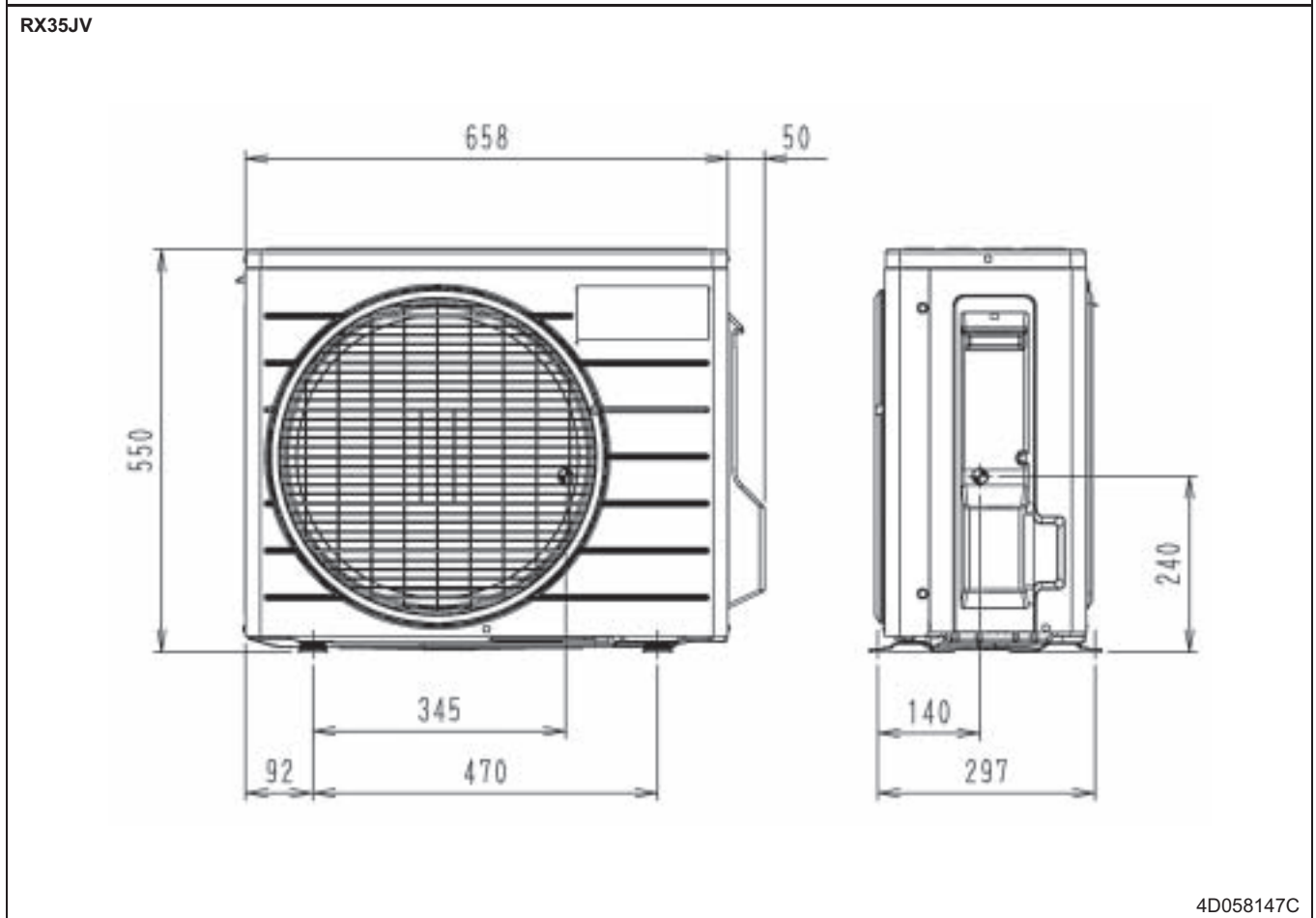
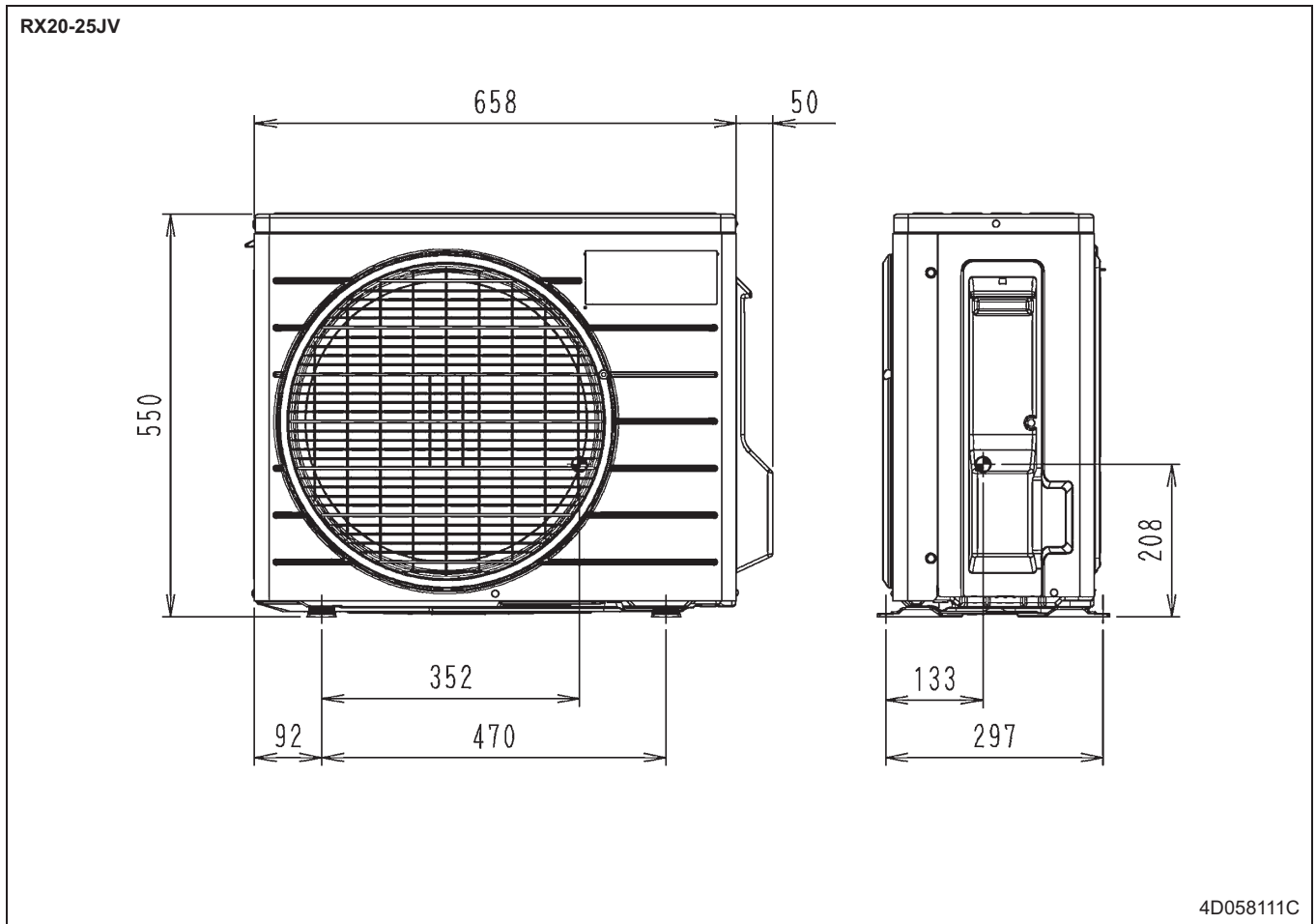

## 5 Dimensional drawing & centre of gravity

### 5 - 2 Centre of gravity

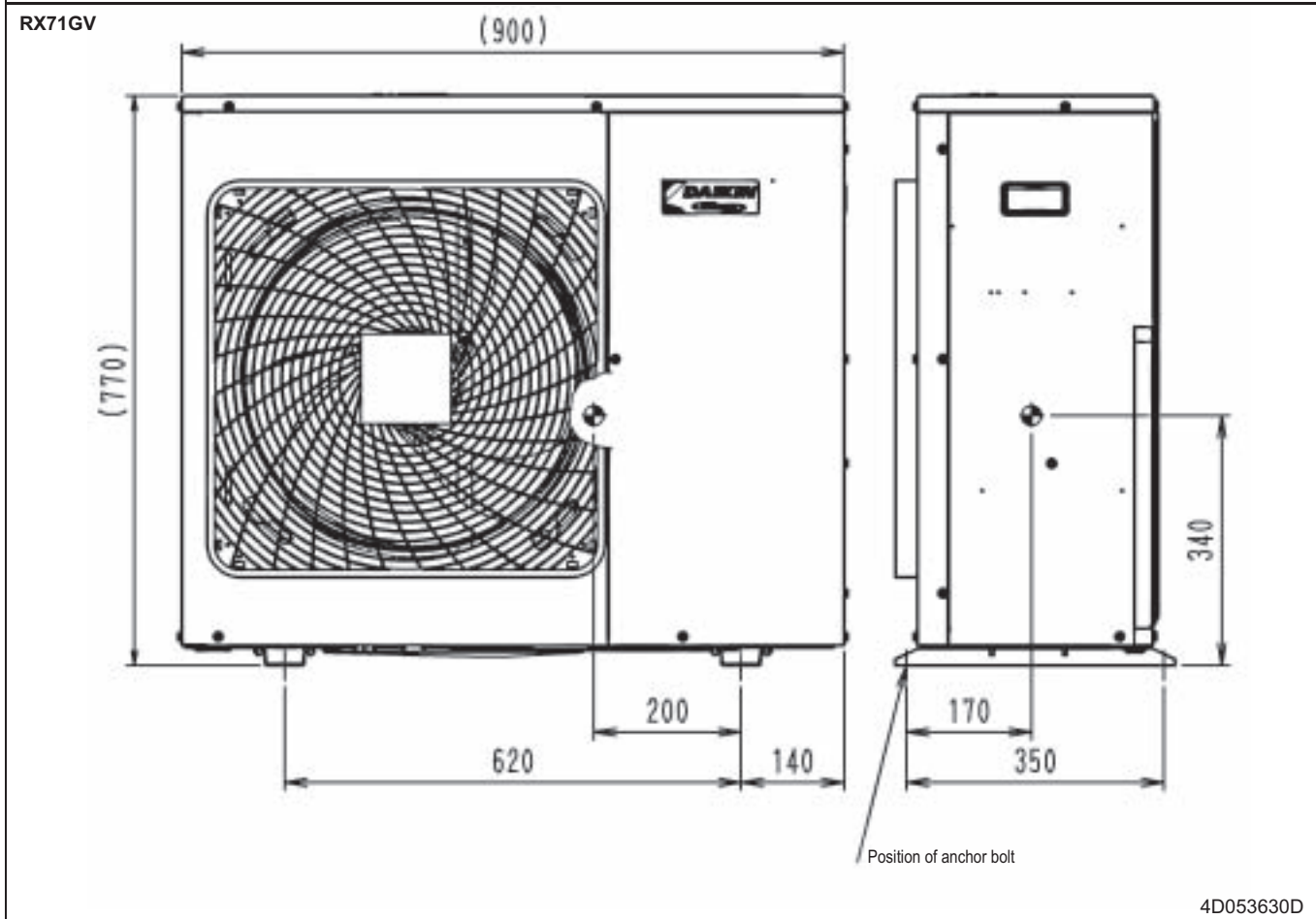
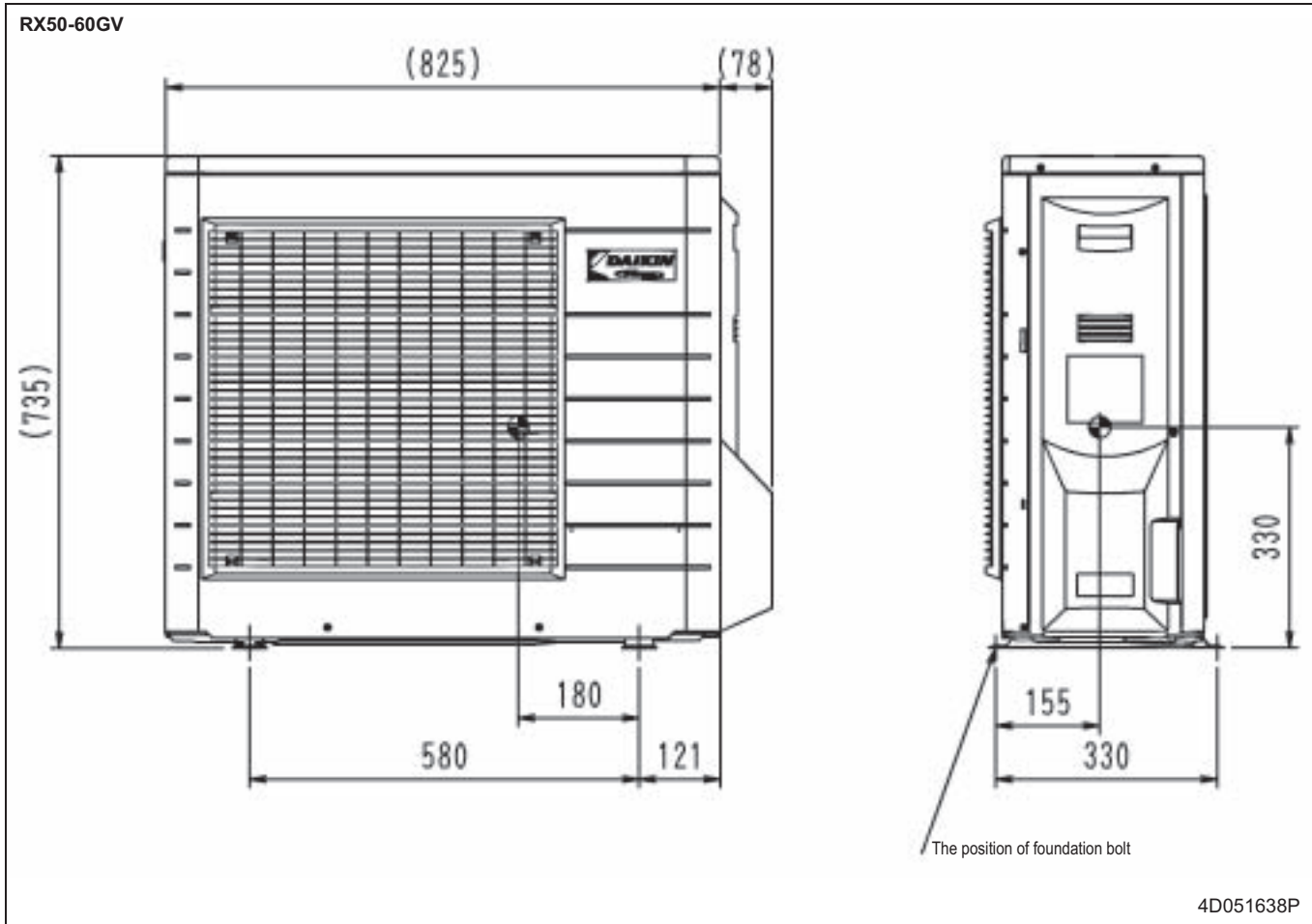

# 6 Piping diagram

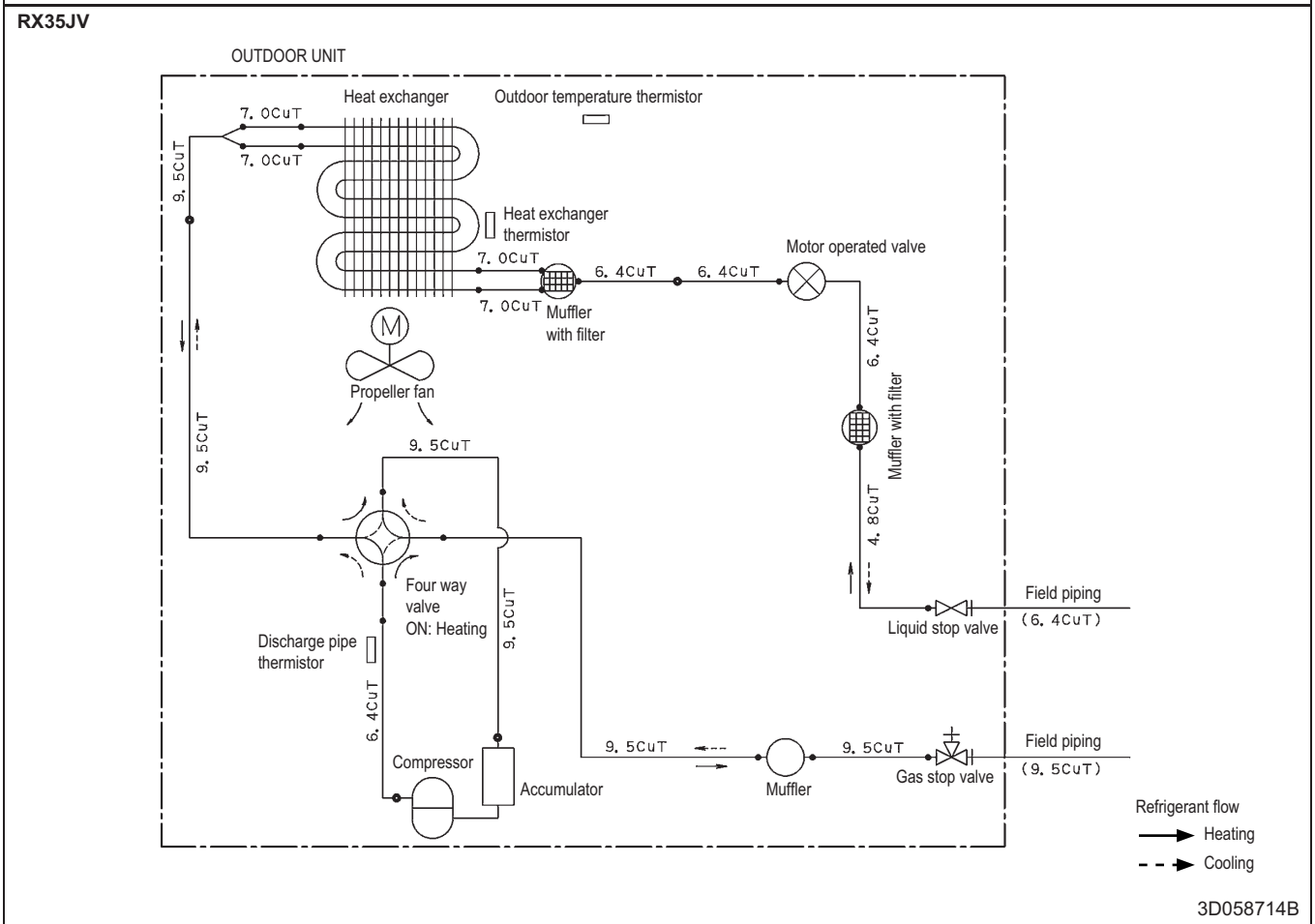
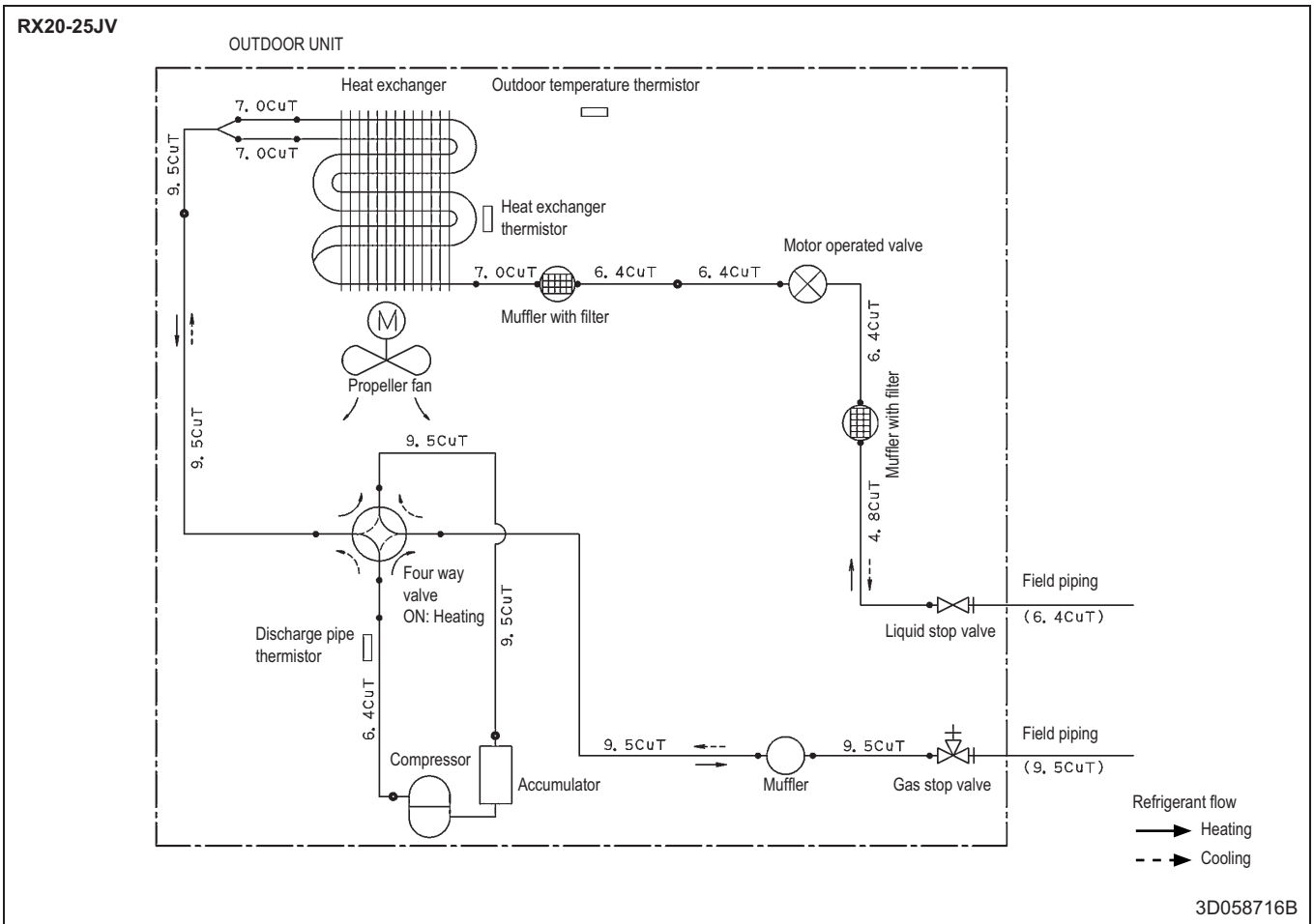

# 6 Piping diagram

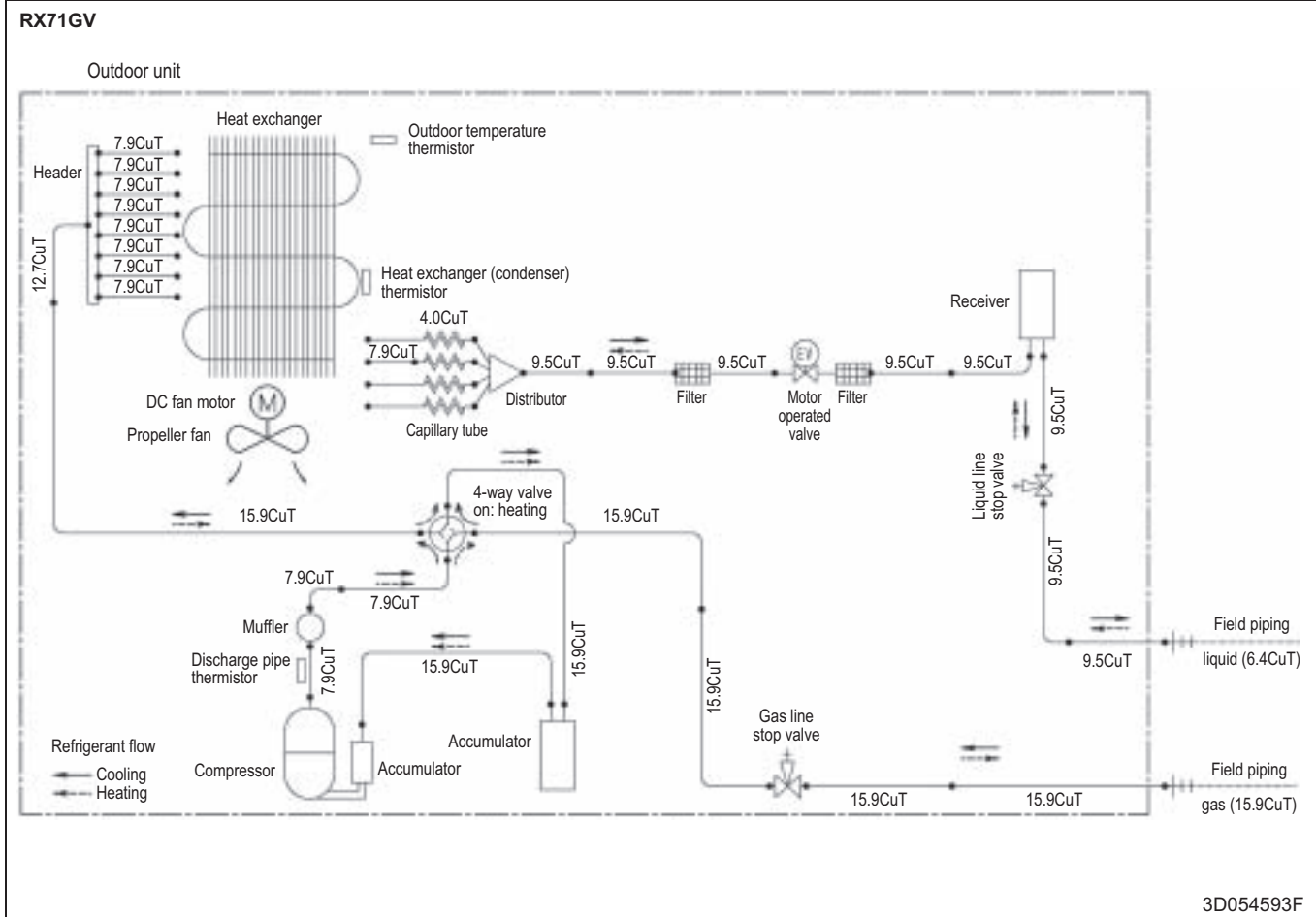
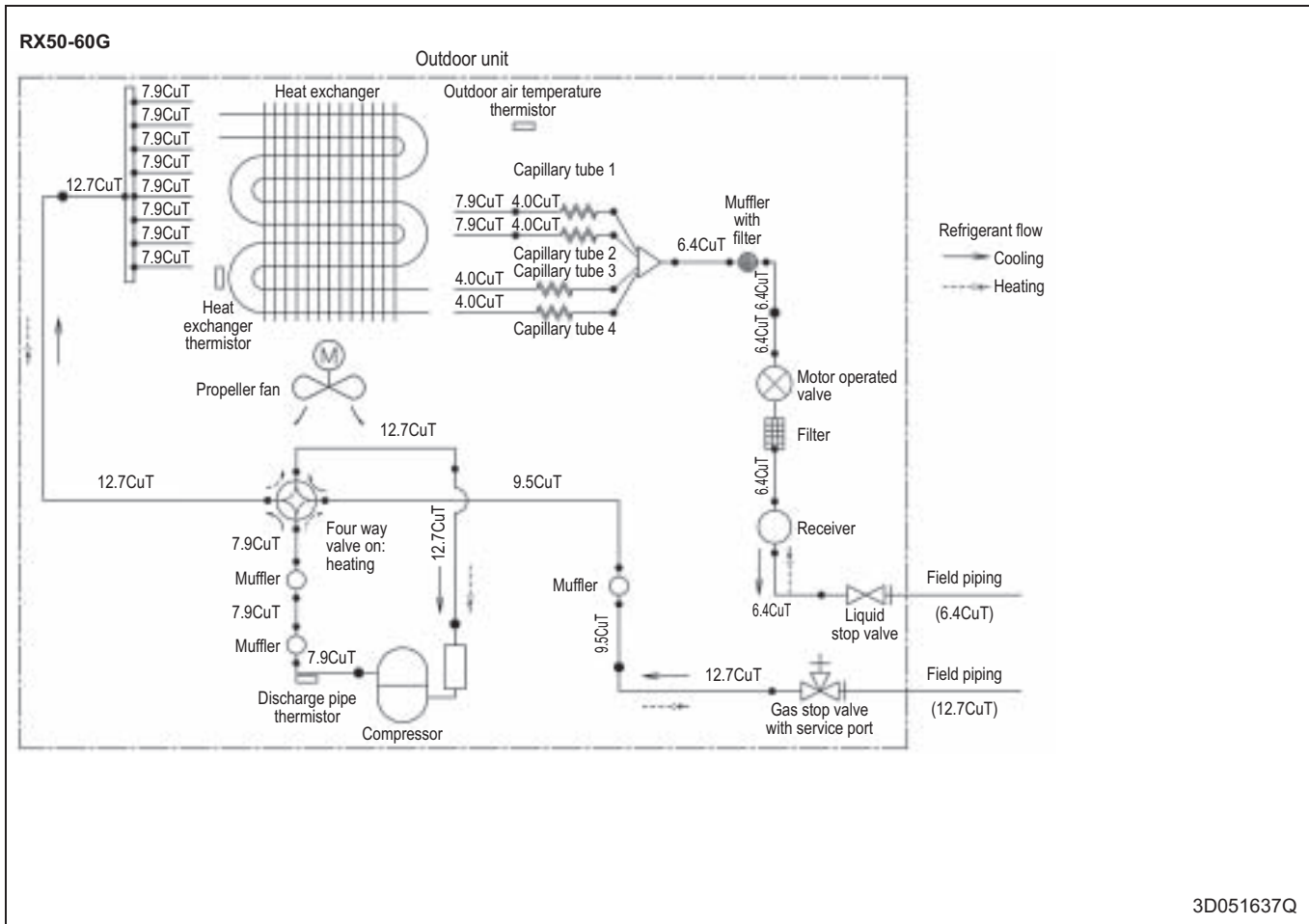

# 7 Wiring diagram

## 7 - 1 Wiring diagram

RX20-35JV

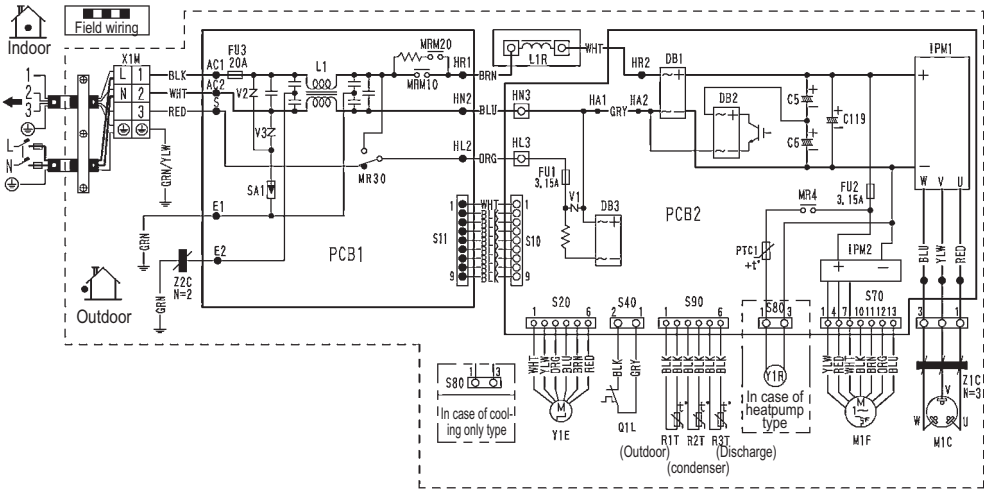

C5, C6, C119	: Capacitor	MR4, MR30, MRM10	: Magnetic relay	R1T, R2T, R3T	: Thermistor
DB1, DB2, DB3	: Diode bridge	MRM20	: Magnetic relay	SA1	: Surge arrester
FU1, FU2, FU3	: Fuse	N	: Neutral	V1, V2, V3	: Varistor
IPM1, IPM2	: Intelligent power module	Q1L	: Overload protector	X1M	: Terminal strip
L	: Live	PCB1, PCB2	: Printed circuit board	Y1E	: Electronic expansion valve coil
L1	: Coil	PTC1	: Thermistor PTC	Y1R	: Reversing solenoid valve coil
L1R	: Reactor	S10, S11, S20, S40	: Thermistor	Z1C, Z2C	: Ferrite core
M1C	: Compressor motor	S70, S80, S90, HL3	: Connector	⊕	: Protective earth
M1F	: Fan motor	HN3	: Connector		

**NOTES**

1 Refer to the nameplate for the power requirements.

3D058406C

# 7 Wiring diagram

## 7 - 1 Wiring diagram

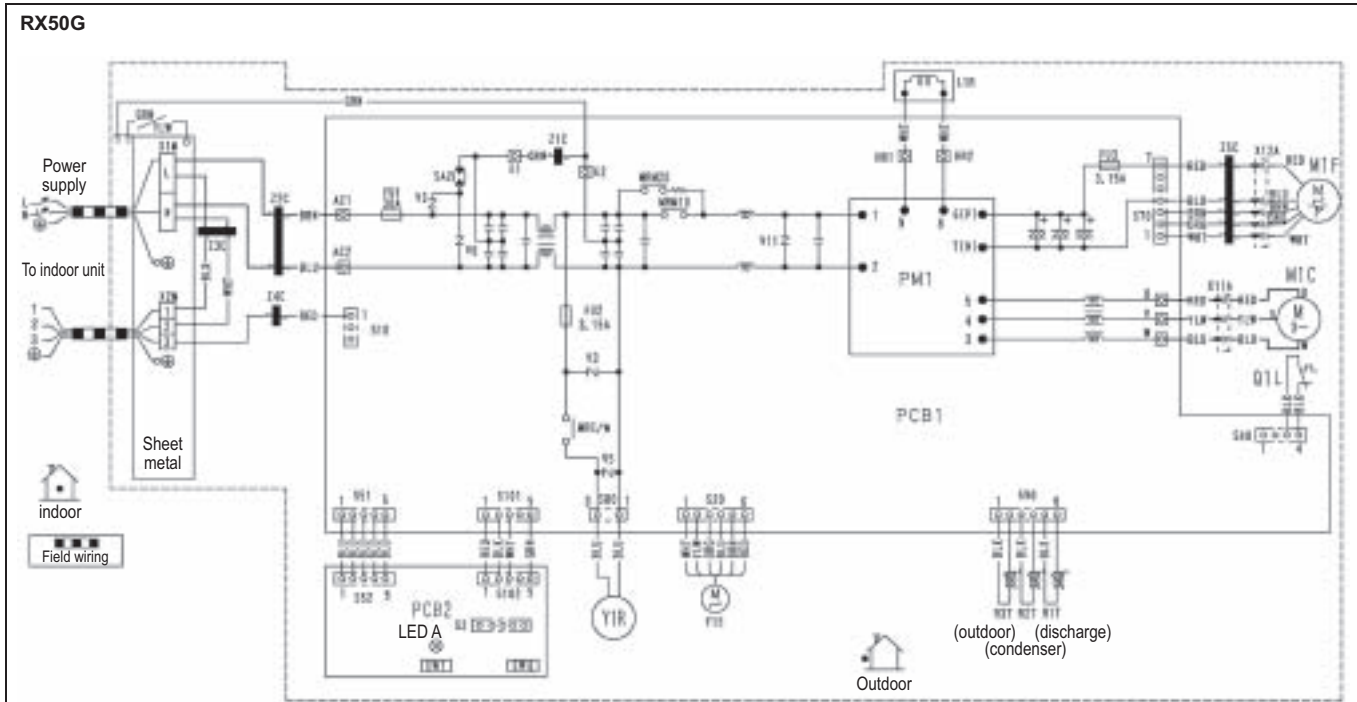

Z1C~Z5C	Ferrite core	LED A	Pilot lamp
X1M, X2M	Terminal strip	L	Live
Y1E	Electronic expansion valve coil	N	Neutral
V2, V3, V5, V6, V11	Varistor	SW1	Forced operation ON/OFF SW (SW1)
SA2	Surge arrester	SW4	Local setting SW (SW4)
FU1, FU2, FU3	Fuse	M1C	Compressor motor
AC1, AC2		M1F	Fan motor
U, V, W, X11A, X12A		L1R	Reactor
E1, E2		Q1L	Overload protector
HR1, HR2	Connector	PM1	Power module
MRM10, MRM20		PCB1, 2	Printed circuit board
MRC/W	Magnetic relay	Y1R	Reversing solenoid valve coil
R1T~R3T	Thermistor	Sheet metal	Terminal strip fixed plate
S2~S102	Connector		

# 7 Wiring diagram

## 7 - 1 Wiring diagram

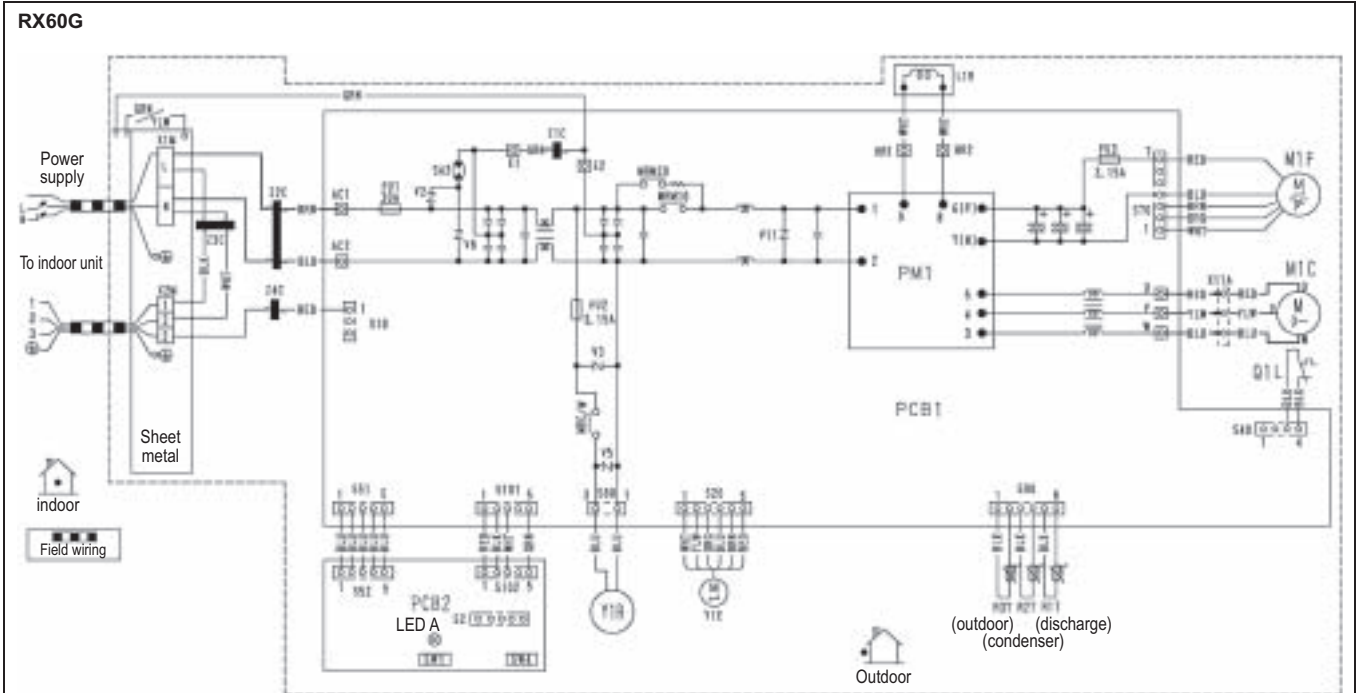

Z1C~Z4C	Ferrite core	LEDA	Pilot lamp
X1M, X2M	Terminal strip	L	Live
Y1E	Electronic expansion valve coil	N	Neutral
V2, V3, V5, V6, V11	Varistor	SW1	Forced operation ON/OFF SW (SW1)
SA2	Surge arrester	SW4	Local setting SW (SW4)
FU1, FU2, FU3	Fuse	M1C	Compressor motor
AC1, AC2		M1F	Fan motor
U, V, W, X11A		L1R	Reactor
E1, E2		Q1L	Overload protector
HR1, HR2	Connector	PM1	Power module
MRM10, MRM20		PCB1, 2	Printed circuit board
MRC/W	Magnetic relay	Y1R	Reversing solenoid valve coil
R1T~R3T	Thermistor	Sheet metal	Terminal strip fixed plate
S2~S102	Connector		



# 7 Wiring diagram

## 7 - 1 Wiring diagram

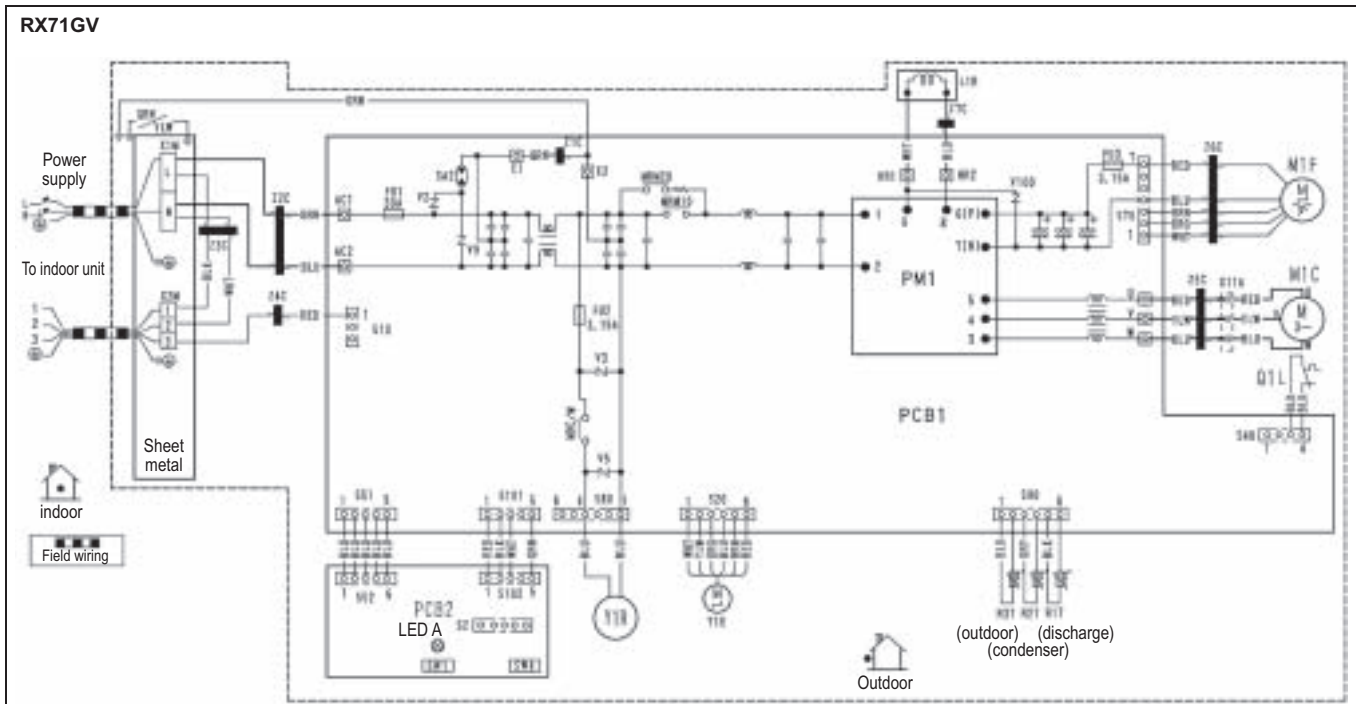

Z1C~Z7C	Ferrite core	LEDA	Pilot lamp
X1M, X2M	Terminal strip	L	Live
Y1E	Electronic expansion valve coil	N	Neutral
V2, V3, V5, V9, V100	Varistor	SW1	Forced operation ON/OFF SW (SW1)
SA2	Surge arrester	SW4	Local setting SW (SW4)
FU1, FU2, FU3	Fuse	M1C	Compressor motor
AC1, AC2		M1F	Fan motor
U, V, W, X11A, X12A		L1R	Reactor
E1, E2		Q1L	Overload protector
HR1, HR2	Connector	PM1	Power module
MRM10, MRM20		PCB1, 2	Printed circuit board
MRC/W	Magnetic relay	Y1R	Reversing solenoid valve coil
R1T~R3T	Thermistor	Sheet metal	Terminal strip fixed plate
S2~S102	Connector		

# 8 Sound data

## 8 - 1 Sound pressure spectrum

RX20JV

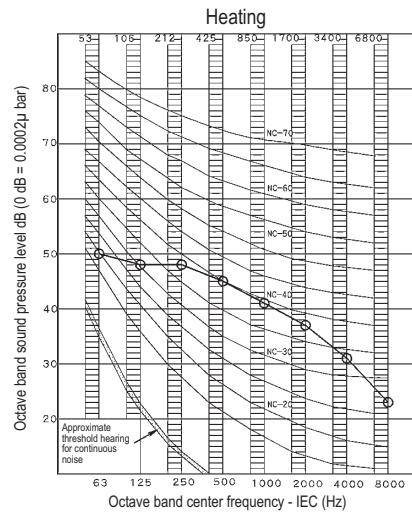
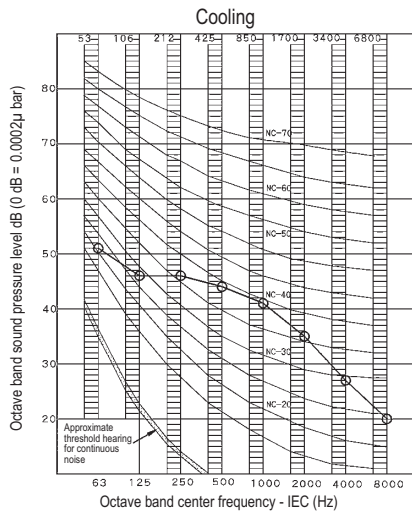

**NOTES**

- Over All (dB): (B,G,N is already rectified)
- Measuring place: measure in anechoic room.
- Operation noise differs with operation and ambient conditions.
- Location of microphone.  
JISC9612  
The operation noise measuring method is in accordance with JISC9612

Scale	50Hz 230v (H)
A	46

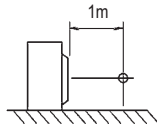

**NOTES**

- Over All (dB): (B,G,N is already rectified)
- Measuring place: measure in anechoic room.
- Operation noise differs with operation and ambient conditions.
- Location of microphone.  
JISC9612  
The operation noise measuring method is in accordance with JISC9612

Scale	50Hz 230v (H)
A	47

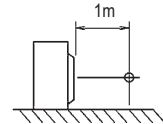

3D059002A

RX25JV

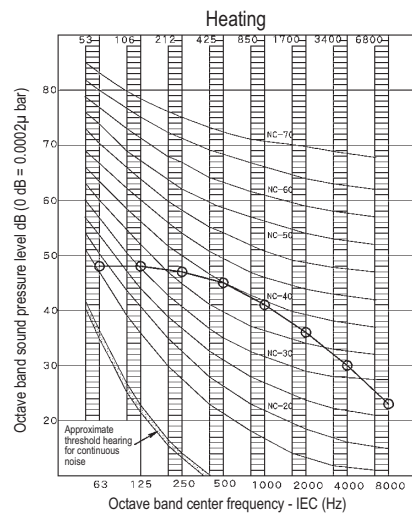
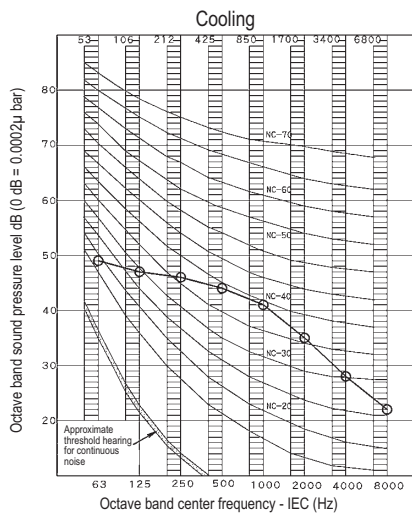

**NOTES**

- Over All (dB): (B,G,N is already rectified)
- Measuring place: measure in anechoic room.
- Operation noise differs with operation and ambient conditions.
- Location of microphone.  
JISC9612  
The operation noise measuring method is in accordance with JISC9612

Scale	50Hz 230v (H)
A	46

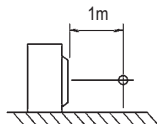

**NOTES**

- Over All (dB): (B,G,N is already rectified)
- Measuring place: measure in anechoic room.
- Operation noise differs with operation and ambient conditions.
- Location of microphone.  
JISC9612  
The operation noise measuring method is in accordance with JISC9612

Scale	50Hz 230v (H)
A	47

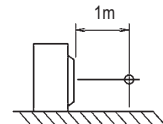

3D059003A

# 8 Sound data

## 8 - 1 Sound pressure spectrum

RX35JV

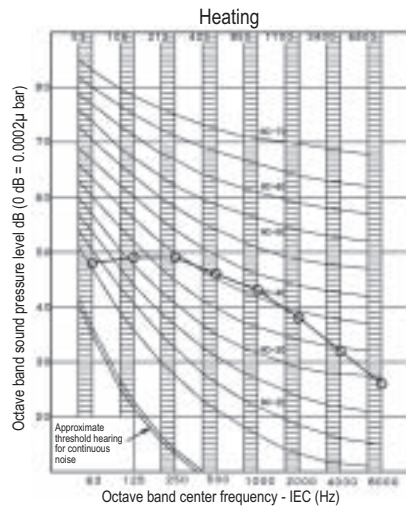
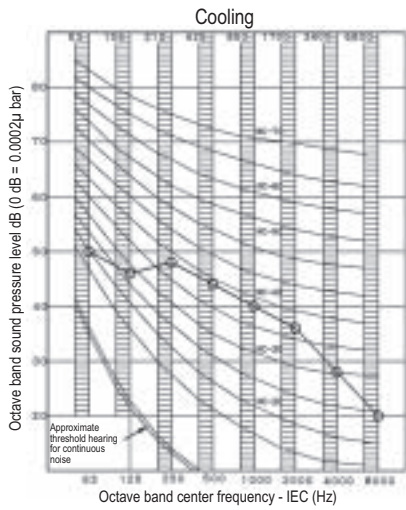

**NOTES**

- Over All (dB): (B,G,N is already rectified)
- Measuring place: measure in anechoic room.
- Operation noise differs with operation and ambient conditions.
- Location of microphone. JISC9612  
The operation noise measuring method is in accordance with JISC9612

Scale	50Hz 230V (H)
A	48

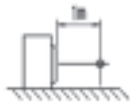

**NOTES**

- Over All (dB): (B,G,N is already rectified)
- Measuring place: measure in anechoic room.
- Operation noise differs with operation and ambient conditions.
- Location of microphone. JISC9612  
The operation noise measuring method is in accordance with JISC9612

Scale	50Hz 230V (H)
A	48

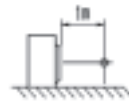

3D059004A

RX50G

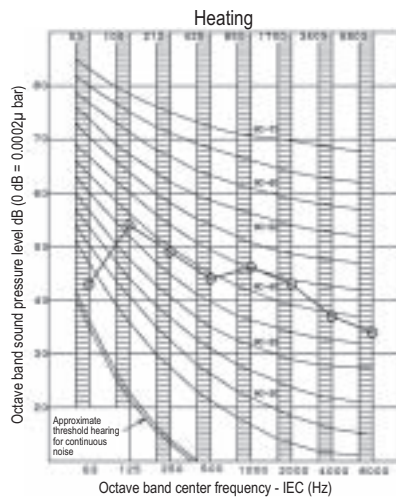
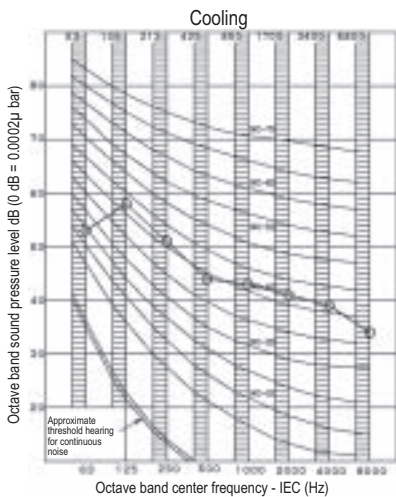

**NOTES**

- Over All (dB): (B,G,N is already rectified)
- Measuring place: measured in anechoic room.
- Operation noise differs with operation and ambient conditions.
- Location of microphone. JIS C 9612  
The operation noise measuring method is in accordance with JIS C 9612

Scale	50Hz 220~240V
A	47

**NOTES**

- Over All (dB): (B,G,N is already rectified)
- Operation noise differs with operation and ambient conditions.

Scale	50Hz 220~240V
A	48

3D051717D

## 8 Sound data

### 8 - 1 Sound pressure spectrum

#### RX60G

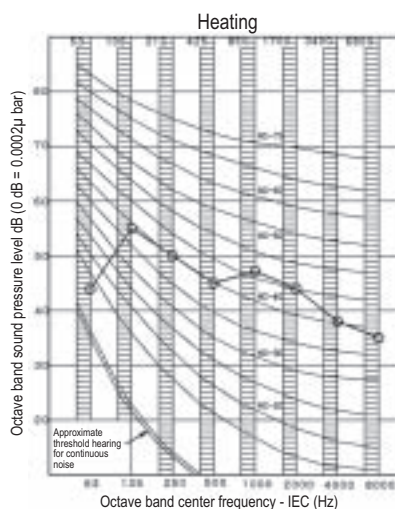
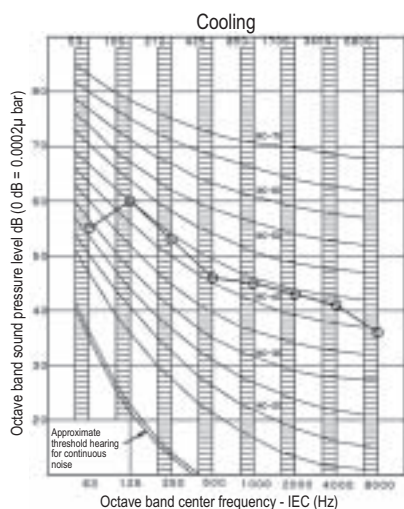

#### NOTES

- Over All (dB):  
(B,G,N is already rectified)
- Measuring place: measured in an echoic room.
- Operation noise differs with operation and ambient conditions.
- Location of microphone.  
JIS C 9612  
The operation noise measuring method is in accordance with JIS C 9612

Scale	50Hz 220~240V
A	49

#### NOTES

- Over All (dB):  
(B,G,N is already rectified)
- Operation noise differs with operation and ambient conditions.

Scale	50Hz 220~240V
A	49

3D051716D

#### RX71GV

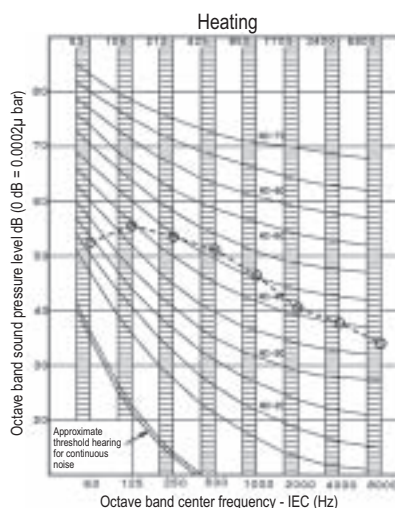
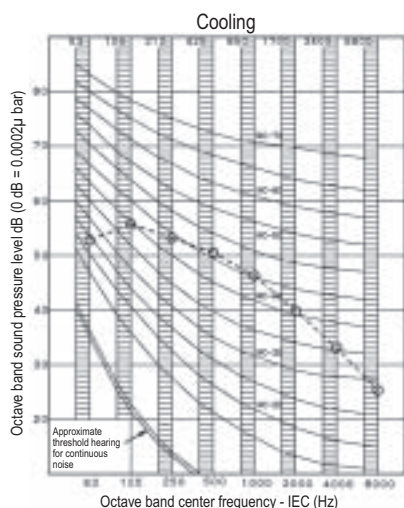

#### NOTES

- Over All (dB):  
(B,G,N is already rectified)
- Measuring place: measured in an anechoic room.
- Operation noise differs with operation and ambient conditions.
- Location of microphone.  
JISC9612  
The operation noise measuring method is in accordance with JISC9612

Scale	50Hz 220~240V
A	52

#### NOTES

- Over All (dB):  
(B,G,N is already rectified)
- Operation noise differs with operation and ambient conditions.

Scale	50Hz 220~240V
A	52

3D055789B

# 9 Operation range

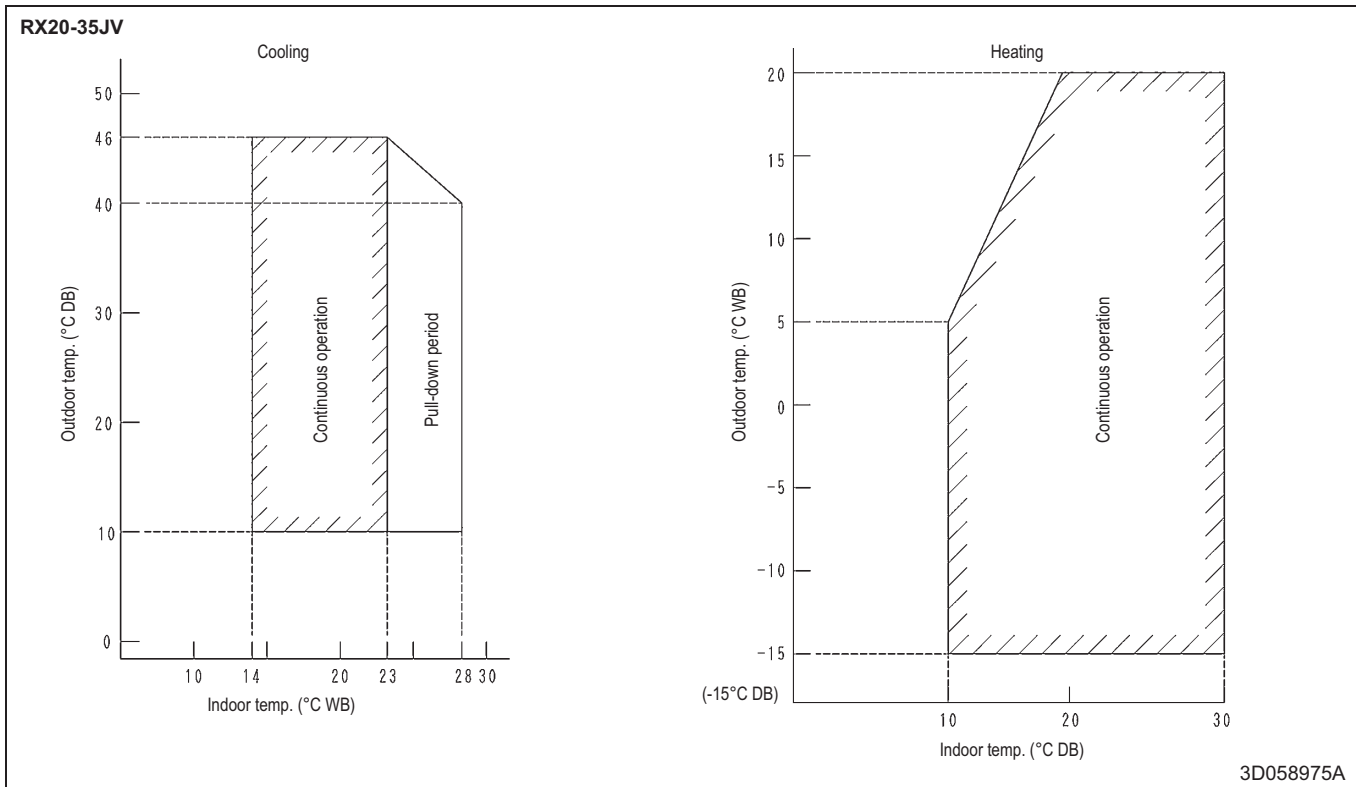

3D058975A

- NOTES**
- The graphs are based on the following conditions.
- Equivalent piping length 5m
  - Level difference 0m
  - Air flow rate High

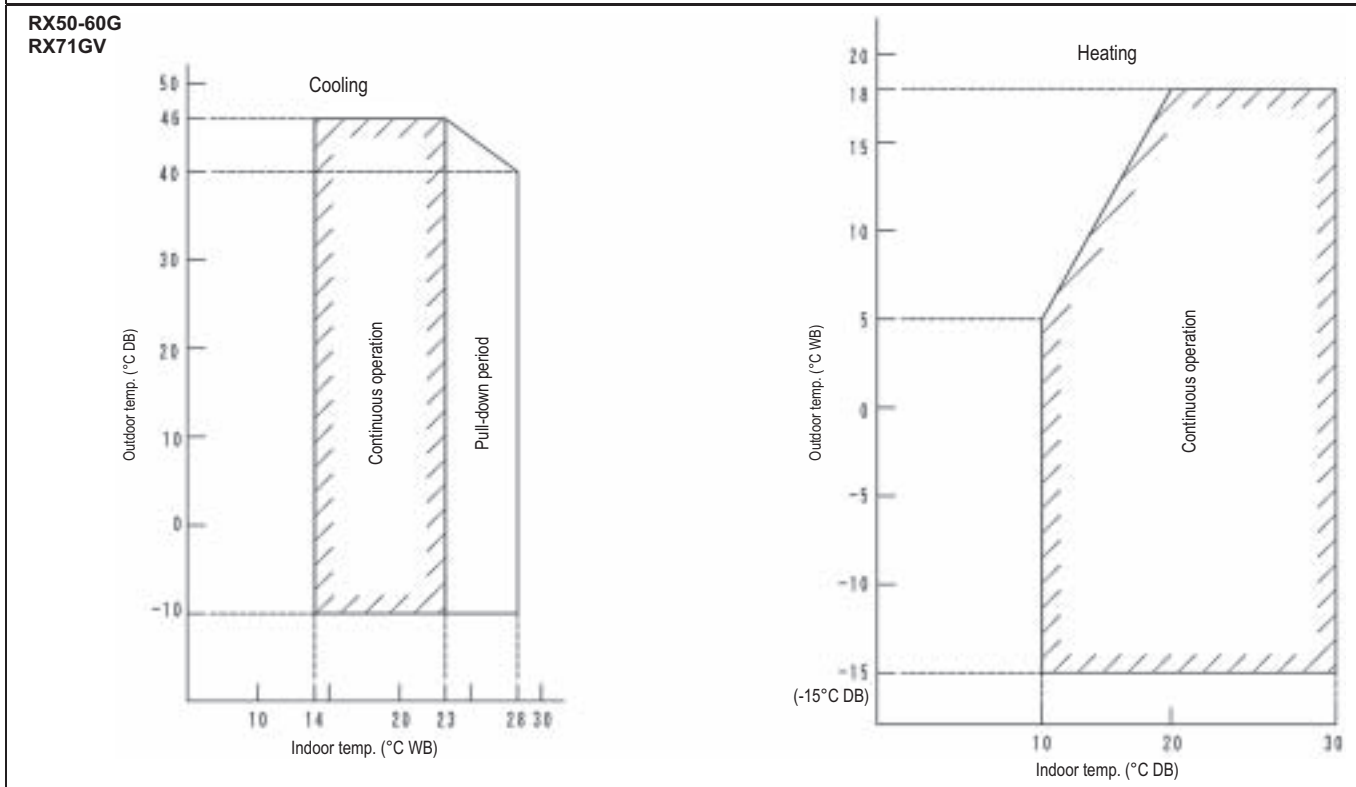

3D028318P

- NOTES**
- The graphs are based on the following conditions.
- Equivalent piping length 7.5m
  - Level difference 0m
  - Air flow rate High



Daikin's unique position as a manufacturer of air conditioning equipment, compressors and refrigerants has led to its close involvement in environmental issues. For several years Daikin has had the intention to become a leader in the provision of products that have limited impact on the environment. This challenge demands the eco design and development of a wide range of products and an energy management system, resulting in energy conservation and a reduction of waste.



The present publication is drawn up by way of information only and does not constitute an offer binding upon Daikin Europe N.V. Daikin Europe N.V. has compiled the content of this publication to the best of its knowledge. No express or implied warranty is given for the completeness, accuracy, reliability or fitness for particular purpose of its content and the products and services presented therein. Specifications are subject to change without prior notice. Daikin Europe N.V. explicitly rejects any liability for any direct or indirect damage, in the broadest sense, arising from or related to the use and/or interpretation of this publication. All content is copyrighted by Daikin Europe N.V.

Daikin products are distributed by:



Daikin Europe N.V. is participating in the EUROVENT Certification Programme. Products are as listed in the EUROVENT Directory of Certified Products.