



Alfa Laval AlfaCubic

Commercial air coolers - Single discharge



Alfa Laval AlfaCubic – Simply fresh, today and tomorrow

AlfaCubic is the Alfa Laval platform for commercial air cooler ranges. Common distinctive features for all Alfa Laval air coolers are the highly efficient cooler coil in combination with many other features, options and benefits.



Energy efficient



Expert reliability



Simple and available

AlfaCubic coolers are commercial single discharge unit coolers for general application in small to medium-sized cooling, freezing and working rooms. A wide range of models make them especially suitable for refrigerated working, processing and storage rooms. Available for both HFC DX and brine refrigerant systems. Dedicated ranges for different application areas. AlfaCubic coolers are available from stock.



Benefits AlfaCubic

- Sufficient space for expansion valve inside casing.
- Eurovent certified performance (CCE models only).
- Easy-install and maintenance. Vertically adjustable drip tray & removable inner drip tray. Hinged side panels.
- Hot-gas defrost ready.
- Energy efficient EC fans available.
- Two-year product guarantee.
- Easy access to on-line product information.

Application areas

AlfaCubic offers dedicated cooler ranges for some common application areas.

Series	GL	RL	BL
Product	Fruit/vegetables	Meat/fish	Frozen food
Room temperature	+10 to 0 °C	0 to -7 °C	-18 to -25 °C
Fins spacing (mm)	4	5.5, 6	7, 8, 10, 11

Other Alfa Laval air cooler ranges

In addition to AlfaCubic commercial single discharge unit coolers, Alfa Laval also offers Optigo CS slim line coolers and highly versatile Airmax II industrial air coolers.



Optigo CS



Airmax II

Alfa Laval AlfaCubic at a glance

- Suitable for all HFC DX and brine refrigerants.
- Triangular (staggered) coil pitch.
- Fin spacings 4, 5.5, 6, 7, 8, 10 & 11 mm.
- 1 to 4 fans, drawing through the coil.
- Room temperatures +10 to -30 °C.
- Capacity range 1.5 up to 60 kW (SC2).
- Air volumes 1527 up to 30350 m³/h.

Standard features

Coil

Internally grooved Cu tubes ø 12 mm and corrugated aluminium fins, smooth tubing for brine applications. Fin spacings 4, 5.5, 6, 7, 8, 10 and 11 mm. Tube pitch is staggered. The coil is fitted with schröder valve on the suction connection for testing purposes.

Casing

Cooler casing is made from corrosion resistant materials. Coil frame AluZinc, casing pre-galvanized sheet steel, powder coated RAL 9002. AlfaCubic coolers are fitted with a hinged drip tray and side covers for easy installation and maintenance. Sufficient space for mounting of expansion valve inside casing. Mounting brackets allow flush ceiling mounting.

Packing

AlfaCubic 250/350 models are delivered in wood-reinforced cardboard boxes, CC 400/500 models in wooden crates. All packings suitable for safe stacking.

Design pressure

Each heat exchanger is leak tested with dry air and finally supplied with a nitrogen pre-charge (DX models).

Model	Refrigerant	Design pressure	Test pressure
AlfaCubic E	HFC DX	33 bar	47 bar
AlfaCubic W	Brine	6 bar	9 bar

Fan motors

1 to 4 fans fitted with AC fan motors, fan diameters 250, 350 mm, 400 or 500 mm drawing through the coil. Power supply 230/50-60/1 or 400/50-60/3 in two noise levels (H/L). Detailed fan data on page 4.



Airsock adapter ring **SR**

Available for fan diameters 400 and 500 mm only.

Driptray insulation **IS**

Not to be combined with electric defrost HG.

Fan ring heater **FRH**

Re-heating coil **RH**

Central terminal box **CB**

Fan motors wired to central terminal box.

Repair switch **SW**

Stainless steel 304 casing & frame **SS**

Fin protection **EP CA**

Epoxy coated fins are available for more aggressive climate conditions.

AlfaStreamer **ST**

Fan streamer to increase air throw by more than 50%. Available for fan diameters 400 and 500 mm only.



Optional features

Defrost systems **E LE HG HD**

For cold rooms with room temperatures below 4 °C and where frost build-up is likely, the application of a defrosting system is advised. The following defrost systems are available for AlfaCubic:

- Electric defrost in coil and driptray (E)
- Electric defrost in coil and driptray light (LE)
- Hotgas defrost in coil & driptray (HG)
- Hotgas defrost + electric in driptray (HG + HD)
- Heater element in driptray (HD)

Electric defrost for AlfaCubic consists of stainless steel heater elements. The defrost elements are connected to separate terminals in the terminal box. Electric defrost capacities on page 6.

Code description

BL	W	H	25	1	A	S	230V	2	CR	AP	E	-	AL	7.0	Cu	IS
1	2	3	4	5	6	7	8	9	10	11	12		13	14	15	16

- AlfaCubic series (BL, GL, RL)
- Refrigerant system (E = dry expansion, W=water/glycol)
- Noise level (H=high, L=low)
- Fan diameter (25=250, 35=350, 40=400, 50=500 mm)
- Number of fans (1 to 4)
- No. of tube rows (A=4, B=6, C=8)
- Phases (S= single phase, D= 3 phases Δ connection)
- Motor voltage (230V, 400V)
- No. of circuits
- Packing (CR=crate)
- Casing material (AP= powder coated, SS= stainless steel)
- Defrost system (A= air, E= electric defrost, HG= hotgas)
- Fin material/coating (AL=aluminium, EP= epoxy coated aluminium)
- Fin spacing (4, 5.5, 6, 7, 8, 10 and 11 mm)
- Tube material (Cu=copper)
- Options

Fan motors

AlfaCubic coolers are available with 1 to 4 fans fitted with AC fan motors, fan diameters 250, 350 mm, 400 or 500 mm drawing through the coil.

Power supply 230/50-60/1 or 400/50-60/3 in two noise levels (H/L). All motors with dynamically and statically balanced external rotors, manufactured in accordance with VDE 0530/12.84.

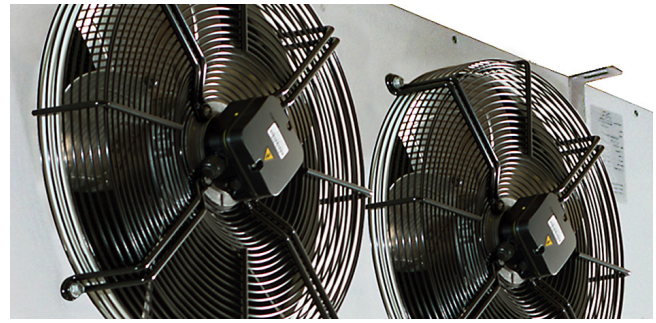

Fan specifications

Fan motor article nr.	Fan diameter mm	Motor type	Volt V	Phases nr.	Fan speed code	Freq. Hz	*Fan speed rpm	*Nominal power W	*Max. current A
AC fans 230-400/50-60/3									
41101242SP	250	AC	230	1	H	50-60	2500	150	0.72
41101179SP	350	AC	230	1	H	50-60	1370	170	0.77
41101165SP	400	AC	230	1	H	50-60	1430	320	1.75
41103249SP	400	AC	400	3	H	50-60	1340	280	0.66
41103249SP	400	AC	400	3	L	50-60	900	120	0.34
41103237SP	500	AC	400	3	H	50-60	1390	720	1.69
41103237SP	500	AC	400	3	L	50-60	870	290	0.89

* Specifications for 50Hz. Maximum current at t = -30 °C.

Quality and certifications

All Alfa Laval air heat exchanger production sites are certified according to ISO 9001 (Quality). Alfa Laval AlfaCubic units are built according to the strictest international standards in terms of safety, energy efficiency and environmental sustainability. All units are given an 18 months guarantee.

Alfa Laval is participant in the Eurovent Certify All programme for air-cooled condensers, dry coolers and DX air coolers. AlfaCubic products are manufactured according to CE and PED regulations.



Worldwide support

Alfa Laval offers worldwide support from product and application specialists via 103 sales offices in 53 countries.

Alfa Laval offers a comprehensive portfolio of parts and services including quality spare parts delivery via channel partners, reconditioning, on-site services, performance agreements, exclusive stock stored, upgrades, consulting services and training.

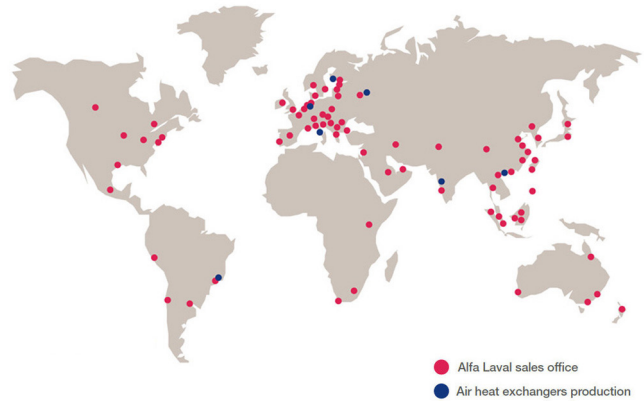

Product selection and information

Our easy-to-use selection software AlfaSelect Air helps you select the most suitable air cooler solution for your specific application. The software provides separate modules for thermal and mechanical design. The data sheet printout provides all relevant technical specifications for the selected cooler model, including detailed dimensional drawings. Additional product information like user manuals, CAD drawings and electrical connections is available for download on the AlfaCubic product page on our website www.alfalaval.com.

The screenshot shows the AlfaSelect AIR software interface. The main window displays the 'AlfaCubic' product selection screen. The 'Design' dropdown is set to 'Direct Expansion'. The 'Family' is '<All Families>' and the 'Type' is 'AlfaCubic'. The 'Series' is 'BL'. The 'Calculation' section shows a capacity of 14.00 kW, air temperature of 0.0 °C, evaporator temperature of -8.0 °C, relative humidity of 85.0%, and a temperature difference of 8.0 K. The 'Fan Input' section shows a power supply of 50Hz, noise level of H, and blade material of Auto Selection. The 'Coil Input' section shows a minimum fin spacing of 7.0 mm, fin material of Aluminium, and tube material of Copper. The 'Air Coolers Single air flow - 50 Hz' table shows the following specifications:

Parameter	Value	Unit
DTM	6.74	[K]
ErP 2015 compliant		
Length	2110.0	[mm]
Height	685.0	[mm]
Depth	630.0	[mm]
Dry weight (approx +/- 5%)	125.1	[kg]
Fin Spacing	7.0	[mm]
Fin Material	Aluminium	
Tube Material	Copper	
Sound power LWA	79	[dB(A)]
Number of fans	3	
Fan diameter	400.0	[mm]
Fan Connection	D	
Voltage	400V	
Rotation speed	1370	[rpm]
Nom. power consumption	1260.0	[W]
Nominal current	2.16	[A]
Full load current (30%)	2.59	[A]

The 'Selected unit' is BLEH403BD 400V BO APA AL 7.0 CU with a total price (RCPL) of 2417 EUR. The software also displays a table of model specifications at the bottom:

Model	Capacity [kW]	Surface Area [m²]	Fin Spacing [mm]	Margin [%]	Air Flow [m³/s]	Air Throw [m]	Sound Pressure [dB(A)]	Sound Power [LWA]	Fan Conn [Speed (rpm)]	Motor	Tot Power Cons [W]	Tot Curr. Abs [A]	Price	Note
BLH403BS	13.41	80.05	7.0	-4.20	2.722	23.81	56	77	-	1430	480.0	2.19	2417	
BLH403BT	14.50	80.05	7.0	3.58	3.299	26.99	58	79	D	1370	1260.0	2.16	2417	

Capacities and technical data

On the next pages you will find capacities and other selection data for air cooler models with 4 and 7 mm fin spacing fitted with AC fan motor types. To select other cooler models please use our AlfaSelect selection software.

Capacity values as given in the left column in the tables on pages 7 and 8 are DT values from room temperature to evaporating temperature. SC cooling capacities are nominal capacities for frosted conditions (Q_n) in compliance with Eurovent regulations and EN328. These nominal values have been calculated from the standard (dry) condition Q_{st} with the following formula: Q_n = Q_{st} x correction factor.

Standard Condition	Air inlet temp. (°C)	Evaporating temp. (°C)	Relative humidity	Correction factor
SC1	10	0	85%	1.35
SC2	0	-8	85%	1.15
SC3	-18	-25	95%	1.05
SC4	-25	-31	95%	1.01

Nominal capacities are calculated with refrigerant R404A. For other refrigerants the following correction factors following the Eurovent Standard Conditions should be applied:

Refrigerant	SC1	SC2	SC3	SC4
R134a	0.93	0.91	0.85	-
R507	0.97	0.97	0.97	0.97
R407F	1.19	1.24	1.29	1.35
R407A	1.19	1.24	1.28	1.32
R22	-	0.97	0.97	-

Air throw

The values given in the tables are for ceiling mounted coolers at t=20°C, an unrestrained air flow in the cold room and a minimal air velocity of 0.25 m/s at the given air throw distance. The height and air circulation of the room may influence the air throw.

Sound pressure dB(A)

Table tables are sound pressure levels in dB(A) at 3 m distance in free field conditions according to EN13487. Values may deviate depending on situations at site.

Electric defrost capacities

Model	Alfa Cubic	Tube rows no.	Standard electric defrost (E)				Light electric defrost (LE)				
			coil heaters no.	power per heater W	total power W	drip tray heaters no.	power drip tray W	coil heaters no.	power per heater W	total power W	drip tray heaters no.
251A	4	2	390	780	1	270	1	390	390	1	270
251B	6	3	390	1170	1	270	2	390	780	1	270
252A	4	2	780	1560	1	540	1	780	780	1	540
252B	6	3	780	2340	1	540	2	780	1560	1	540
253A	4	2	1180	2360	1	800	1	1180	1180	1	800
253B	6	3	1180	3540	1	800	2	1180	2360	1	800
351A	4	3	390	1170	1	270	2	390	780	1	270
351B	6	4	390	1560	1	270	2	390	780	1	270
352A	4	3	780	2340	1	540	2	780	1560	1	540
352B	6	4	780	3120	1	540	2	780	1560	1	540
353A	4	3	1180	3540	1	800	2	1180	2360	1	800
353B	6	4	1180	4720	1	800	2	1180	2360	1	800
354A	4	3	1570	4710	1	1000	2	1570	3140	1	1000
354B	6	4	1570	6280	1	1000	2	1570	3140	1	1000
401B	6	7	450	3150	1	450	4	450	1800	1	450
401C	8	9	450	4050	1	450	5	450	2250	1	450
402B	6	7	900	6300	1	900	4	900	3600	1	900
402C	8	9	900	8100	1	900	5	900	4500	1	900
403B	6	7	1250	8750	1	1250	4	1250	5000	1	1250
403C	8	9	1250	11250	1	1250	5	1250	6250	1	1250
502A	4	4	1600	6400	1	1600	2	1600	3200	1	1600
502B	6	6	1600	9600	1	1600	3	1600	4800	1	1600
502C	8	8	1600	12800	1	1600	4	1600	6400	1	1600
503B	6	6	2800	16800	1	2800	3	2800	8400	1	2800
503C	8	8	2800	22400	1	2800	4	2800	11200	1	2800
504B	6	7	2600	18200	1	2600	4	2600	10400	1	2600
504C	8	10	2600	26000	1	2600	5	2600	13000	1	2600

Model	Capacities R404A DX		Fan data								Connections	
	room temp. 0 °C evap. temp. -8 °C	SC2*	nr.	power supply V/ph	fan power W	air throw m	sound press. dB(A)	air flow m ³ /h	coil surface m ²	Int. volume dm ³	in	out mm
GLEH												
Fin spacing 4 mm												
251A	2.5	2.0	1	230/1	150	13.3	56	1435	12.8	1.3	½"	12
251B	3.4	2.5	1	230/1	150	12.8	56	1371	19.2	2	½"	12
252A	5.0	4.0	2	230/1	300	15.0	59	2870	25.6	2.7	½"	22
252B	6.9	5.1	2	230/1	300	14.6	59	2742	38.4	4	½"	22
253A	7.3	6.0	3	230/1	450	16.1	61	4306	38.4	4	½"	22
253B	10.2	7.7	3	230/1	450	15.6	61	4113	57.7	6	½"	22
351A	4.0	3.2	1	230/1	150	16.3	49	2375	21.4	2.2	½"	22
351B	5.5	4.2	1	230/1	150	15.5	49	2219	32.0	3.4	½"	22
352A	8.3	6.6	2	230/1	300	18.8	52	4749	42.7	4.5	½"	28
352B	10.6	8.3	2	230/1	300	17.9	52	4438	64.1	6.7	½"	28
353A	12.4	10.0	3	230/1	450	20.2	54	7124	64.1	6.7	½"	28
353B	16.5	12.7	3	230/1	450	19.4	54	6657	96.1	10.1	5/8"	28
354A	16.4	13.3	4	230/1	600	21.2	55	9498	85.4	9	5/8"	35
354B	21.6	16.7	4	230/1	600	20.4	55	8876	128.1	13.4	5/8"	35
401B	7.8	5.9	1	230/1	160	19.0	51	3178	43.8	4.6	½"	28
401C	9.1	6.7	1	230/1	160	18.3	51	3014	58.4	6.1	½"	28
402B	15.9	12.1	2	230/1	320	21.9	54	6403	90.0	9.4	5/8"	35
402C	18.9	13.8	2	230/1	320	21.2	54	6081	119.9	12.6	5/8"	35
403B	23.8	18.2	3	230/1	480	23.5	56	9626	136.1	14.3	22	42
403C	28.0	20.7	3	230/1	480	22.8	56	9148	181.5	19	22	42
401B	8.4	6.5	1	400/3	420	22.0	53	3830	43.8	4.6	½"	28
401C	9.7	7.4	1	400/3	420	21.0	53	3607	58.4	6.1	½"	28
402B	16.9	13.3	2	400/3	840	24.9	56	7722	90.0	9.4	5/8"	35
402C	20.4	15.3	2	400/3	840	23.9	56	7285	119.9	12.6	5/8"	35
403B	25.3	20.0	3	400/3	1260	26.6	58	11610	136.1	14.3	22	42
403C	30.0	22.9	3	400/3	1260	25.6	58	10960	181.5	19	22	42
502A	20.9	18.3	2	400/3	1440	38.0	58	15780	107.0	11.2	16	35
502B	30.6	24.5	2	400/3	1440	36.6	58	15050	160.5	16.8	22	35
502C	37.2	28.6	2	400/3	1440	35.4	58	14390	214.0	22.4	22	42
503B	45.0	36.6	3	400/3	2160	38.7	60	22600	242.2	25.4	22	42
503C	56.4	43.2	3	400/3	2160	37.5	60	21620	322.9	33.9	28	42
504B	60.6	49.1	4	400/3	2880	40.2	61	30160	323.9	34	28	54
504C	75.5	57.8	4	400/3	2880	39.0	61	28850	431.9	45.3	28	54

* Eurovent standard condition SC2

Model	Capacities R404A DX		nr.	Fan data							Connections	
	room temp. -18 °C evap. temp. -25 °C	SC3*		power supply V/ph	fan power W	air throw m	sound press. dB(A)	air flow m ³ /h	coil surface m ²	Int. volume dm ³	OD in out mm	
BLEH	kW	kW										
Fin spacing 7 mm												
251A	1.3	1.1	1	230/1	150	13.5	56	1461	7.5	1.3	½"	12
251B	1.8	1.5	1	230/1	150	13.1	56	1413	11.3	2	½"	12
252A	2.6	2.3	2	230/1	300	15.2	59	2923	15.1	2.7	½"	22
252B	3.7	3.1	2	230/1	300	14.9	59	2826	22.6	4	½"	22
253A	3.7	3.4	3	230/1	450	16.2	61	4384	22.6	4	½"	22
253B	5.4	4.7	3	230/1	450	15.9	61	4239	33.9	6	½"	22
351A	2.1	1.9	1	230/1	150	16.7	49	2442	12.6	2.2	½"	22
351B	2.9	2.5	1	230/1	150	16.0	49	2319	18.9	3.4	½"	22
352A	4.2	3.8	2	230/1	300	19.1	52	4885	25.1	4.5	½"	28
352B	5.7	5.0	2	230/1	300	18.5	52	4638	37.7	6.7	½"	28
353A	6.3	5.7	3	230/1	450	20.5	54	7327	37.7	6.7	½"	28
353B	8.8	7.6	3	230/1	450	19.9	54	6957	56.5	10.1	5/8"	28
354A	8.4	7.6	4	230/1	600	21.5	55	9770	50.3	9	5/8"	35
354B	11.5	10.1	4	230/1	600	20.9	55	9276	75.4	13.4	5/8"	35
401B	4.2	3.6	1	230/1	160	19.6	51	3297	25.8	4.6	½"	28
401C	5.0	4.2	1	230/1	160	18.9	51	3155	34.4	6.1	½"	28
402B	8.4	7.3	2	230/1	320	22.4	54	6634	52.9	9.4	5/8"	35
402C	10.5	8.7	2	230/1	320	21.8	54	6356	70.6	12.6	5/8"	35
403B	12.6	10.9	3	230/1	480	24.1	56	9969	80.1	14.3	22	42
403C	15.6	13.0	3	230/1	480	23.4	56	9557	106.7	19	22	42
401B	4.4	3.9	1	400/3	420	22.8	53	3996	25.8	4.6	½"	28
401C	5.4	4.6	1	400/3	420	21.9	53	3797	34.4	6.1	½"	28
402B	9.0	7.9	2	400/3	840	25.7	56	8047	52.9	9.4	5/8"	35
402C	11.2	9.5	2	400/3	840	24.8	56	7659	70.6	12.6	5/8"	35
403B	13.4	11.9	3	400/3	1260	27.3	58	12100	80.1	14.3	22	42
403C	16.5	14.2	3	400/3	1260	26.4	58	11520	106.7	19	22	42
502A	11.3	10.5	2	400/3	1440	38.6	58	16120	62.9	11.2	16	35
502B	16.5	14.6	2	400/3	1440	37.5	58	15510	94.4	16.8	22	35
502C	20.2	17.5	2	400/3	1440	36.5	58	14950	125.9	22.4	22	42
503B	23.7	21.4	3	400/3	2160	39.6	60	23300	142.5	25.4	22	42
503C	30.6	26.4	3	400/3	2160	38.5	60	22460	190.0	33.9	28	42
504B	31.9	28.7	4	400/3	2880	41.0	61	31080	190.5	34	28	54
504C	41.0	35.4	4	400/3	2880	40.0	61	29970	254.0	45.3	28	54

* Eurovent standard condition SC3

Dimensions

Model	Dimensions					Shipping volume m ³	Weights (fin spacing 7 mm)		
	AlfaCubic	A	B	C	D		E	Model A kg	Model B kg
251	970	530	460	395	410	0.43	17	19	-
252	1470	1030	460	395	410	0.63	28	33	-
253	1970	1530	460	395	410	0.84	42	47	-
351	970	530	460	585	410	0.57	32	39	-
352	1470	1030	460	585	410	0.84	48	55	-
353	1970	1530	460	585	410	1.10	69	78	-
354	2470	2030	460	585	410	1.37	100	102	-
401	1040	600	630	685	530	0.90	-	44	48
402	1640	1200	630	685	530	1.33	-	87	96
403	2240	1800	630	685	530	1.90	-	125	135
502	2140	1700	650	830	530	2.20	174	188	201
503	2990	2550	650	830	530	3.10	-	249	258
504	3840	3400	650	830	530	3.90	-	321	359

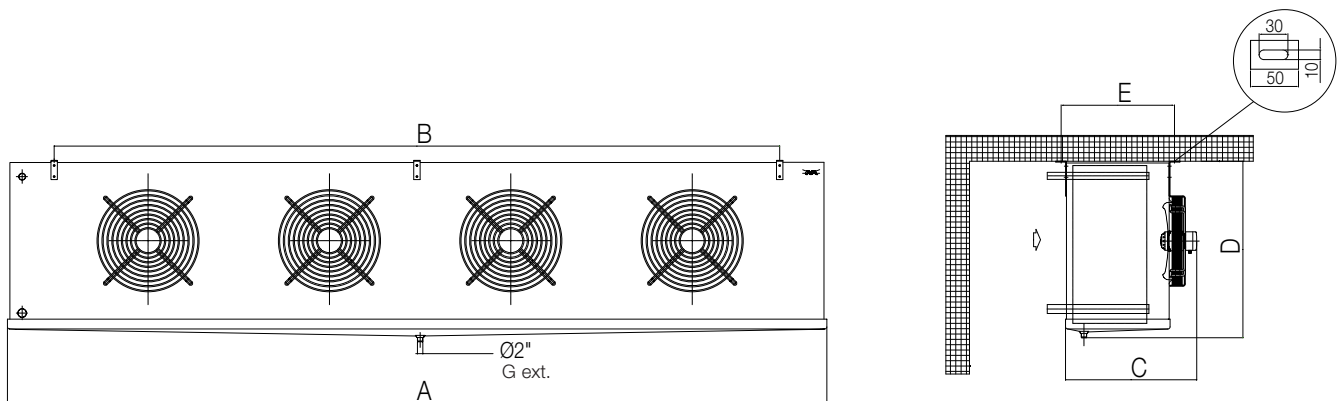

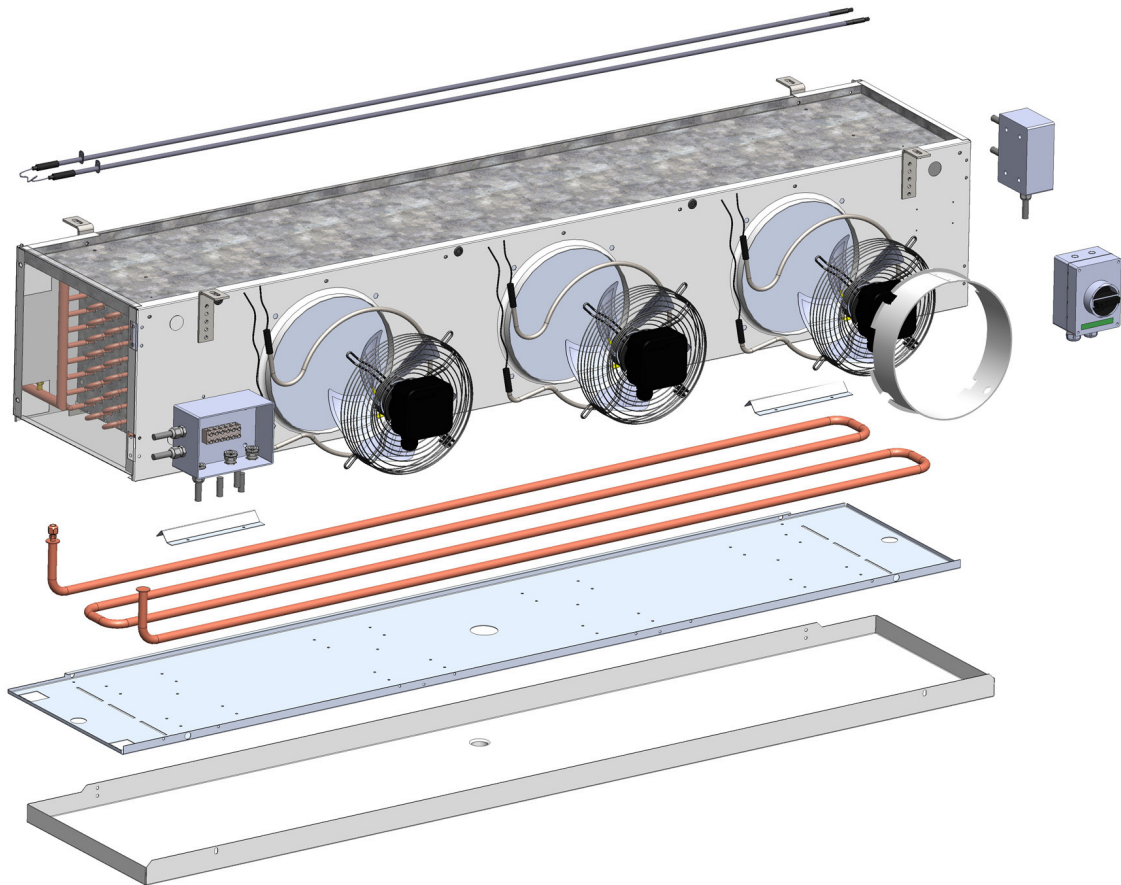

Spare parts AlfaCubic		Article no.
AC fan motors	∅	
1ph/230V/50-60Hz	250	41101242SP
1ph/230V/50-60Hz	350	41101179SP
1ph/230V/50-60Hz	400	41101165SP
3ph/400V/50-60Hz H/L	400	41103249SP
3ph/400V/50-60Hz H/L	500	41103237SP

Spare parts AlfaCubic	Article number	
	230V	400V
Terminal box 251/351/401	41018185	41018190
Terminal box 252/352/402	41018186	41018191
Terminal box 253/353/403	41018187	41018192
Terminal box 354	41002139	41018193
Terminal box 502		41018194
Terminal box 503		41018195
Terminal box 504		41018196

Spare parts AlfaCubic	Article number	
	coil	drip tray
Electric defrost heaters		
Defrost heater 251	41001002SP	41001028SP
Defrost heater 252	41001003SP	41001029SP
Defrost heater 253	41001004SP	41001030SP
Defrost heater 351	41001002SP	41001028SP
Defrost heater 352	41001003SP	41001029SP
Defrost heater 353	41001004SP	41001030SP
Defrost heater 354	41001240SP	41001031SP
Defrost heater 401	41001005SP	41001005SP
Defrost heater 402	41001054SP	41001054SP
Defrost heater 403	41001055SP	41001055SP
Defrost heater 502	41001058SP	41001058SP
Defrost heater 503	41001059SP	41001059SP
Defrost heater 504	41001060SP	41001060SP

Spare parts AlfaCubic	Article number
Drip trays	
Drip tray AlfaCubic 251	60104088SP
Drip tray AlfaCubic 252	60104089SP
Drip tray AlfaCubic 253	60104090SP
Drip tray AlfaCubic 351	60104088SP
Drip tray AlfaCubic 352	60104089SP
Drip tray AlfaCubic 353	60104090SP
Drip tray AlfaCubic 354	60104091SP
Drip tray AlfaCubic 401	60104092SP
Drip tray AlfaCubic 402	60104093SP
Drip tray AlfaCubic 403	60104094SP
Drip tray AlfaCubic 502	60104116SP
Drip tray AlfaCubic 503	60104117SP
Drip tray AlfaCubic 504	60104118SP

Spare parts AlfaCubic	Article no.
Fan ring heaters	
Fan ring heaters AlfaCubic 250 models	41001077SP
Fan ring heaters AlfaCubic 350 models	41001071SP
Fan ring heaters AlfaCubic 400 models	41001066SP
Fan ring heaters AlfaCubic 500 models	41001067SP
Supports, stainless steel (4 per fan)	60112015SP
Air streamer	
Air streamer AlfaCubic 400 models	41199107SP
Air streamer AlfaCubic 500 models	41199136SP
Defrost heater connection box	
Connection box 250/350 models	41002162SP
Connection box 400/500 models	41002193SP

Alfa Laval in brief

Alfa Laval is a leading global provider of specialized products and engineered solutions.

Our equipment, systems and services are dedicated to helping customers optimize the performance of their processes. Time and time again.

We help our customers to heat, cool, separate and transport products such as oil, water, chemicals, beverages, food-stuffs, starch and pharmaceuticals.

Our worldwide organization works closely with customers in almost 100 countries to help them stay ahead.

How to contact Alfa Laval

Up-to-date contact details for all countries are always available on our corporate website at www.alfalaval.com. You can also download product information and selection software.



AlfaCubic

Alfa Laval channel partner

