



HANBELL SCREW COMPRESSORS

HVAC & Refrigeration Type

With Internal Oil Separator



**Efficient, Quiet
& Cost Effective**



RC18 ~ RC21

162 Tons ~ 334 Tons

RC Series HVAC & Refrigeration Screw Compressors

**+5°F ~ +59°F
-15°C ~ +15°C**

R22

R134a

R407C

R404A

R507



Compressor Specifications:

Description		RC18	RC19	RC20	RC21	
Compressor	Displacement @ 60 Hz.	CFH	23661	25956	33619	36162
	Displacement @ 50 Hz.	CFH	19246	21118	27333	29382
	Rated Speed	RPM	60 Hz. = 3550 & 50 Hz. = 2950			
	Volume Ratios Available	Vi	2.2, 2.4, 2.6, 3.0, 3.5, 4.8			
	Capacity Control System	%	Modulating Capacity Control between 25% & 100%			
	Refrigerant		R22, R134a, R407C, R404A, R507A			
	Lubrication		Differential Pressure Feed Lubrication			
	Oil Heater Wattage	Watts	150 Watts			
	Lubricant Type	Mineral	SUN SUNISO - 5GS or CPI 4214-320			
	Lubricant Type	POE	CPI SOLEST - 370			
	Hydrostatic Pressure Test	PSIG	600			
	Discharge Connection Size	inches	3 1/8" O.D.	3" I.P.S.	4" I.P.S.	4" I.P.S.
	Suction Connection Size	inches	4 1/8" O.D.	5" I.P.S.	5" I.P.S.	5" I.P.S.
	Compressor Weights	Lbs.	1940	2183	2690	2734
Compressor Weights	kg	880	990	1220	1240	
Motor	Motor & Voltage Phase	Type	3 Phase, 2 Pole, Induction Motor			
	Starting Methods	YD	YD Starting ~ (60Hz. and 50Hz.)			
	Voltage Availability	60 Hz	460/3/60, 575/3/60 - Standard			
	Voltage Availability	50 Hz	380/3/50, 400/3/50, 415/3/50			
	Insulation	Type	Class F			
	Protection	Type	PTC Protection			

Performance Data ~ R22 ~ 60Hz

RC Series Model	Water/Evaporative Cooled Ratings						Air Cooled Ratings					
	35°F SST & 105°F SCT			45°F SST & 105°F SCT			35°F SST & 120°F SCT			45°F SST & 120°F SCT		
	Capacity	Power	EER	Capacity	Power	EER	Capacity	Power	EER	Capacity	Power	EER
	Tons	kW	BTU/h/w	Tons	kW	BTU/h/w	Tons	kW	BTU/h/w	Tons	kW	BTU/h/w
RC18	178.0	142.8	15.0	215.6	151.7	17.1	161.8	165.5	11.7	196.5	175.8	13.4
RC19	195.8	156.6	15.0	237.0	166.4	17.1	177.9	181.6	11.8	216.1	192.8	13.4
RC20	256.1	202.7	15.2	310.0	215.4	17.3	232.7	234.9	11.9	282.6	250.3	13.6
RC21	276.2	218.1	15.2	334.4	231.7	17.3	250.9	252.8	11.9	304.8	268.5	13.6

RC Series ~ Sound Data

Model Numbers	RC18	RC19	RC20	RC21	Sound Data Notes:	
R22 ~ Nominal Capacity in Tons	189	208	271	293		
Sound Data Frequency in Hz.	63	61.9	62.2	62.6	62.8	<ol style="list-style-type: none"> The 1/3 octave band spectrum data shown to the left is based on 122°F (50°C) SCT, & 32°F (0°C) SST, & R22 The sound data is compatible for R22, R134a, R407C, R404A & R507A providing the compressor is operated within normal operating limits. The sound data is very similar for all refrigerants and working conditions, with +/- 2dBa OVERALL tolerance. The sound data is based on ISO-2151 Standards. Other sound frequency data may be available upon request.
	125	63.9	64.3	64.6	64.9	
	250	72.0	72.5	72.9	73.1	
	500	68.7	69.1	69.5	69.8	
	1000	71.3	71.7	72.2	72.4	
	1600	75.3	75.7	76.2	76.4	
	2000	74.0	74.4	74.8	75.1	
	2500	74.0	74.4	74.8	75.1	
4000	69.4	69.8	70.2	70.5		
8000	53.9	54.2	54.4	54.7		
Overall dB(A)	86.3	86.8	87.3	87.6		

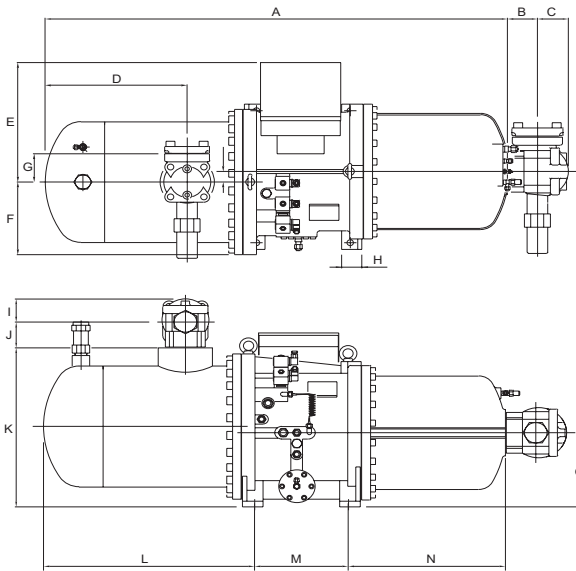

RC18 Only

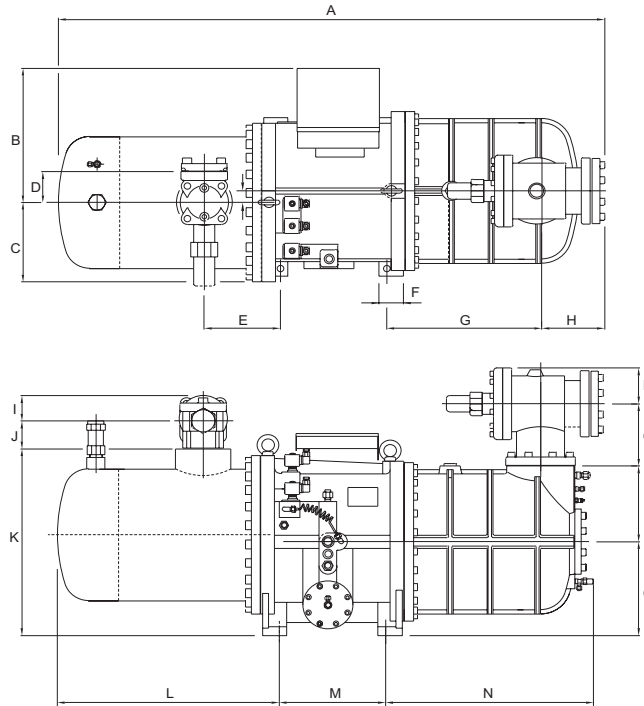
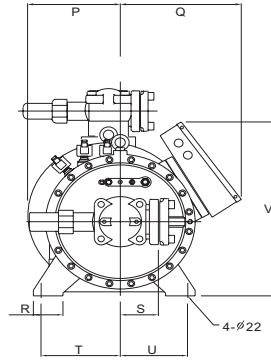

RC19-21

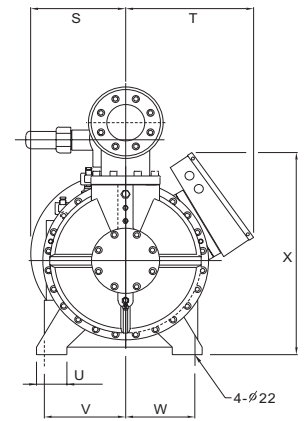

Outline Dimensions:

Compressor Model	Dimensions in Inches ~ Converted from Metric "mm"											
	A	B	C	D	E	F	G	H	I	J	K	L
RC18	62.05	4.04	4.13	19.06	17.83	10.83	4.21	2.76	3.46	3.82	23.74	28.35
RC19	71.36	18.35	10.83	4.21	9.94	3.15	20.26	8.21	3.46	3.82	25.51	29.90
RC20-21	80.06	18.35	10.83	5.12	10.33	3.15	20.26	8.21	4.13	4.06	25.71	32.38
Model	M	N	O	P	Q	R	S	T	U	V	W	X
RC18	12.60	21.10	11.02	12.40	16.26	3.94	5.12	10.63	9.06	25.98	-	-
RC19	13.90	27.17	12.80	10.35	8.48	4.88	12.40	16.77	3.94	10.63	9.06	27.60
RC20-21	16.46	29.92	12.80	10.35	8.48	4.88	12.40	16.77	3.94	10.63	9.06	27.60

Compressor Features:

Multi-Nation Patents of High Efficiency Screw Rotor

The new 5:6 ratio high efficiency rotor profile is patented in Taiwan, US, UK, Japan and China. This new high volume, high efficiency rotor profile was designed specifically for modern refrigerant characteristics. The new higher efficiency is accomplished by using precision CNC machining centers, rotor milling machines, rotor grinding machines and cutter sharpening machines. Strict ISO 9001 process control and the use of precise inspection equipment, such as ZEISS 3D coordinate measuring equipment, ensures efficient, high quality, low noise, low vibration Hanbell RC Series Compressors for worldwide distribution.

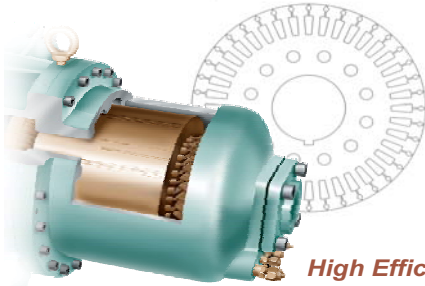

High Efficiency Motor

High Efficiency Motor

Premium-grade low-loss core steel with the special RC motor cooling slot design plus the inner & outer refrigerant guide design pilots the cool suction refrigerant gas through the motor, providing the highest operating efficiency possible no matter how difficult the operating conditions.

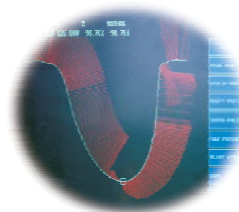

CNC Cutter
Measuring System

CNC Cutter
Sharpening
Machine

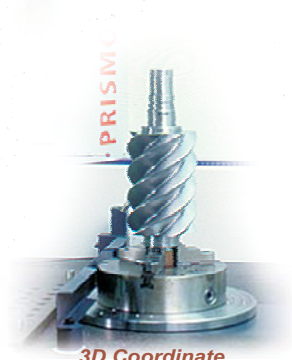

3D Coordinate
Measuring-Male Rotor

Overall Range of Volume Ratio (Vi)

The compressor Volume Ratio (Vi) is the ratio between the suction and discharge operating conditions and Hanbell can provide specific Vi ratios for special applications. The use of various refrigerants such as R22, R134a, R404A, R407C, plus widely varying operating conditions may require the use of specific Vi ratio compressors. There are several built-in volume ratios offered (Vi=2.2, 2.6, 3.0, 3.5, 4.8) to provide the most efficient compressor for the application.

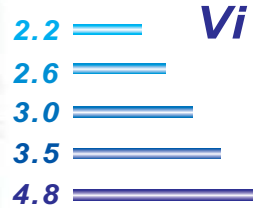
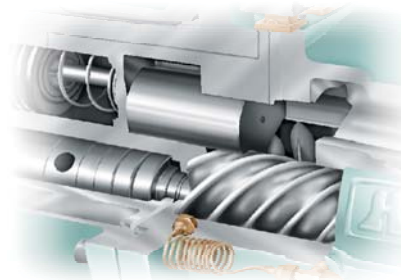

Comprehensive Vi



B-Type Bearing System

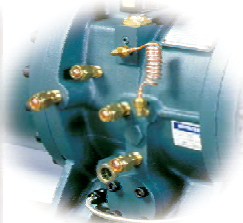

Economizer,
Liquid Injection,
& Oil Cooler Ports

Long Life Bearings & High Reliability

The RC Series Screw Compressor utilizes a combination of 11 B-Type bearings & the α -Type axial balance piston design for excellent bearing life and superior compressor reliability. Adding standard accessories such as economizer, liquid injection for compression chamber cooling, liquid injection for motor cooling and an oil cooler, when needed for specific applications, will increase performance and improve operating efficiency up to 8% plus further extend the compressor bearing life and compressor reliability.

Efficient, Quiet
& Cost Effective