



Compressor Selection: Semi-hermetic Reciprocating Compressors

Input Values

Compressor model Mode	(6G-30.2Y) Refrigeration and Air conditioning	Suction gas temperature Operating mode	20,00 °C Auto
Refrigerant Reference temperature Liq. subc. (in condenser)	R404A Dew point temp. 0 K	Power supply Capacity Control Useful superheat	400V-3-50Hz 100% 100%

Result

Q [W] Qu* [W] P [kW] I [A] Qc [W]	Cooling capacity Evaporator capacity Power input Current Condenser Capacity	COP [-] m [kg/h] Op. th [°C]	COP/EER Mass flow Operating mode Discharge gas temp. w/o cooling
---	---	---	---

tc	to	-5°C	-10°C	-15°C	-20°C	-25°C	-30°C	-35°C	-40°C
30°C	Q [W]	98278	81168	66365	53605	42658	33320	25408	18755
	Qu* [W]	98278	81168	66365	53605	42658	33320	25408	18755
	P [kW]	26,8	25,1	23,2	21,2	19,07	16,84	14,53	12,16
	I [A]	46,0	43,4	40,6	37,6	34,5	31,3	28,2	25,3
	Qc [W]	125036	106232	89568	74803	61728	50160	39939	30919
	COP [-]	3,67	3,24	2,86	2,53	2,24	1,98	1,75	1,54
	m [kg/h]	2469	2019	1637	1313	1039	807	613	451
	Op.	Standard	Standard	Standard	Standard	Standard	Standard	Standard	Standard
	th [°C]	71,4	77,9	84,8	92,3	100,4	109,4	119,3	130,5
	40°C	Q [W]	83997	69321	56575	45546	36047	27911	20984
Qu* [W]		83997	69321	56575	45546	36047	27911	20984	15126
P [kW]		30,8	28,5	26,0	23,4	20,7	17,89	15,06	12,20
I [A]		52,3	48,6	44,8	40,8	36,8	32,8	28,9	25,4
Qc [W]		114847	97809	82565	68922	56717	45801	36045	27329
COP [-]		2,72	2,43	2,18	1,95	1,74	1,56	1,39	1,24
m [kg/h]		2378	1941	1569	1253	985	759	568	408
Op.		Standard	Standard	Standard	Standard	Standard	Standard	Standard	Standard
th [°C]		82,7	89,4	96,4	104,0	112,3	121,3	131,3	0
50°C		Q [W]	--	57604	46888	37580	29536	22623	16716
	Qu* [W]	--	57604	46888	37580	29536	22623	16716	11702
	P [kW]	--	31,4	28,3	25,2	21,9	18,66	15,36	12,06
	I [A]	--	53,1	48,4	43,6	38,7	33,9	29,3	25,2
	Qc [W]	--	89021	75225	62751	51475	41284	32078	23762
	COP [-]	--	1,83	1,65	1,49	1,35	1,21	1,09	0,97
	m [kg/h]	--	1865	1502	1193	930	708	520	363
	Op.	--	Standard	Standard	Standard	Standard	Standard	Standard	Standard
	th [°C]	--	100,7	107,9	115,7	124,2	133,5	0	0

-- No calculation possible (see message in single point selection)

*According to EN12900 (20°C suction gas temp., 0K liquid subcooling)

Application Limits 100%

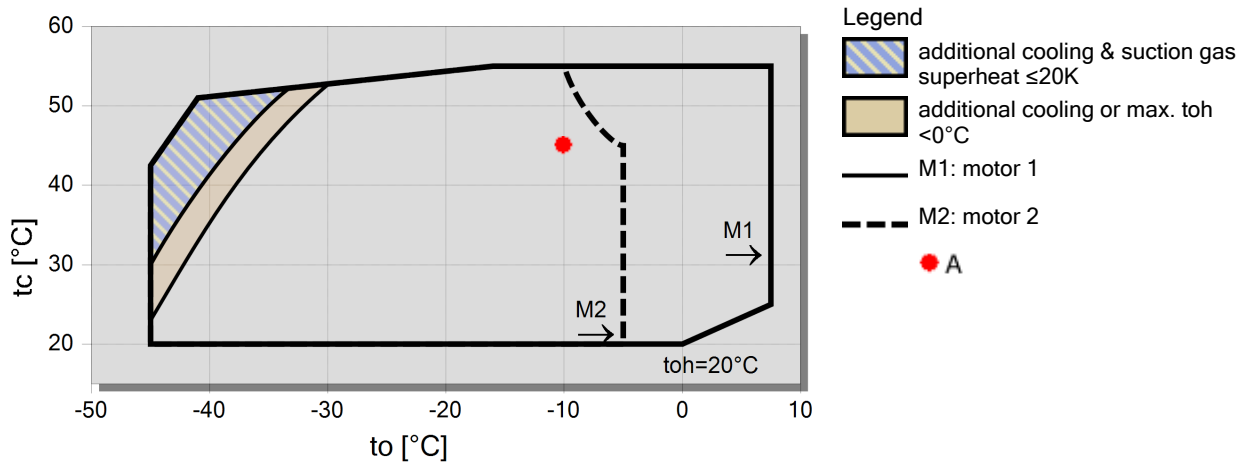



Technical Data: (6G-30.2Y)

Dimensions and Connections

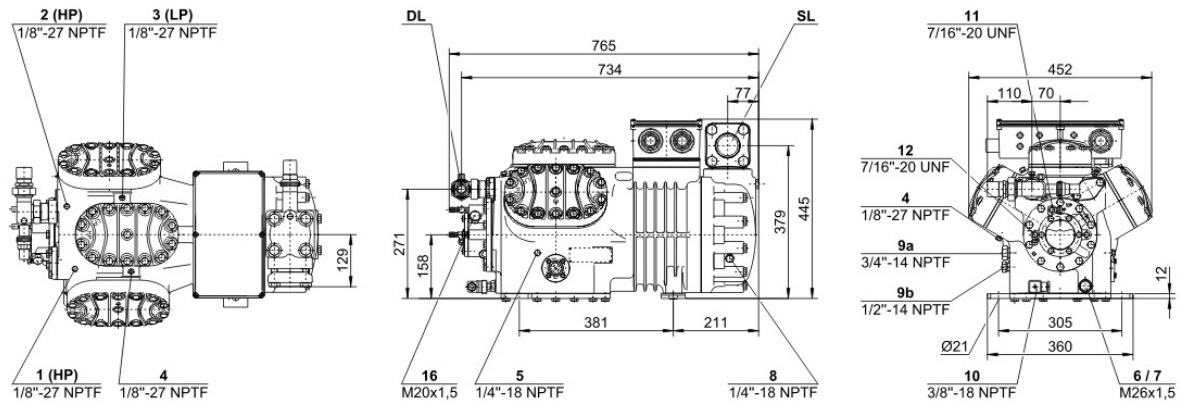

Technical Data

Technical Data

Displacement (1450 RPM 50Hz)	126,8 m ³ /h
Displacement (1750 RPM 60Hz)	153,0 m ³ /h
No. of cylinder x bore x stroke	6 x 75 mm x 55 mm
Weight	228 kg
Max. pressure (LP/HP)	19 / 28 bar
Connection suction line	54 mm - 2 1/8"
Connection discharge line	35 mm - 1 3/8"
Connection cooling water	R 3/4"
Oil type R134a/R407C/R404A/R507A/R407A/R407F	tc<55°C: BSE32 / tc>55°C: BSE55 (Option)
Oil type R22 (R12/R502)	B5.2 (Standard)
Oil type R290/R1270	SHC226E (Standard)

Motor data

Motor voltage (more on request)	380-420V PW-3-50Hz
Max operating current	53.0 A
Winding ratio	50/50
Starting current (Rotor locked)	135.0 A Y / 220.0 A YY
Max. Power input	32,7 kW

Extent of delivery (Standard)

Motor protection	SE-B2
Enclosure class	IP54 (Standard), IP66 (Option)
Vibration dampers	Standard
Oil charge	4,75 dm ³

Available Options

Discharge gas temperature sensor	Option
Start unloading	Option
Capacity control	100-66-33% (Option)
Additional fan	Option
Water-cooled cylinder heads	Option
CIC System	Option
Oil service valve	Option
Crankcase heater	140 W (Option)
Oil pressure monitoring	MP54 (Option), Delta-PII (Option, not for R290/R1270)

Sound measurement

Sound power level (-10°C / 45°C)	83,5 dB(A) @ 50Hz
Sound power level (-35°C / 40°C)	90,5 dB(A) @ 50Hz
Sound pressure level @ 1m (-10°C / 45°C)	75,5 dB(A) @ 50Hz
Sound pressure level @ 1m (-35°C / 40°C)	82,5 dB(A) @ 50Hz