

Grasso Self-Limiting Automatic Purger CE PED

Installation and Maintenance Manual (IMM)

ca0317_0089293_imm_gp_ceped-v005_gbr_



Copyright

All Rights reserved. No part of this publication may be copied or published by means of printing, photocopying, microfilm or otherwise without prior written consent of **Grasso**.

This restriction also applies to the corresponding drawings and diagrams.

Legal Notice

This publication has been written in good faith. However, **Grasso** cannot be held responsible, neither for any errors occurring in this publication nor for their consequences.

SAFETY

GENERAL PRACTICES

1. Keep your hands clear of the fan when the purger unit is running. This should also be observed when opening and closing the cover.
2. Be sure gauge manifold hoses are in good condition. Never let them come into contact with a fan, any other moving parts or hot surfaces.
3. Always wear goggles or safety glasses. Refrigerant can permanently damage the eyes (see first aid on this page).
4. Never apply heat to a sealed refrigerating system.
5. Halocarbon refrigerants, in the presence of an open flame or electrical short, produce toxic gases that are severe respiratory irritants capable of causing death. For this reason do not smoke when working with a refrigerating system.
6. Painful laceration can be inflicted from the fins of the purger condenser.
7. Use caution when working with a refrigerant or refrigerating system in any enclosed or confined area with a limited air supply (for example in a container). Halocarbon refrigerants tend to displace air and cause oxygen depletion which may result in death by suffocation.

REFRIGERANT

Although halocarbon refrigerants are classified as safe refrigerants, certain precautions must be observed when handling them or servicing a unit in which they are used. When released into the atmosphere from the liquid state, halocarbon refrigerants evaporate rapidly, freezing anything they contact. For reasons of environmental protection, however, halocarbon refrigerants should not be released into the atmosphere, but be collected in a container.

FIRST AID

In the event of frost bite, the objectives of first aid are to protect the frozen area from further injury, to warm the affected area rapidly and to maintain respiration;

1. Cover the frozen part
2. Provide extra clothing and blankets
3. Give the victim a warm drink (not alcohol), if the victim is able to drink selfsupportingly
4. Warm the frozen part quickly by immersing it in warm water. Not in hot water!
5. If warm water is not available or practical to use, wrap the affected part gently in a sheet and warm blankets.
6. If refrigerant contacts the eyes, flush them immediately with water.
7. Obtain medical assistance as soon as possible.

Table of Contents

Section	Title	Page
1	INSTALLATION AND PREPARATION FOR USE	9
1.1	GENERAL	9
1.2	FACTORY SETTINGS	9
1.3	MOUNTING THE UNIT	9
1.3.1	Molecular masses	10
1.3.2	Drawing Fig. 1.3-1, P1	10
1.3.3	Drawings Fig. 1.3-1 and Fig. 1.3-2, P2 P3, P4, P5	10
1.3.4	Graphics	11
1.4	POWER CONNECTION	14
1.5	INSTALLATION CHECKLIST AND STARTING	14
1.6	DISMOUNTING THE UNIT	14
2	INSPECTION, MAINTENANCE AND REPAIR	15
2.1	GENERAL	15
2.2	INSPECTION	15
2.3	REPAIR	15
2.3.1	DISASSEMBLY OF FAN MOTOR	15
3	TROUBLE SHOOTING	17
3.1	GENERAL	17
3.2	DIAGNOSIS TABLE	17
4	MISCELLANEOUS	19
4.1	TECHNICAL SPECIFICATIONS AND SETTINGS	19
4.2	EXPLODED VIEW AND DIMENSIONED SKETCH	20
4.3	WIRING DIAGRAM	22
5	NOTES	25

PREFACE/SCOPE

1) General

This manual contains information concerning the installation, maintenance, trouble diagnosis and repair of the Grasso Self-Limiting Automatic Purger of non-condensable gases. It is absolutely necessary that maintenance and repair are carried out by trained personnel, who are familiar with general refrigeration techniques and with the specifications and operation of the purger. Further all personnel working on or near refrigeration installations must be familiar with the current safety precautions.

2) Air and water-vapour



If air enters an ammonia refrigeration plant the water-vapour will be totally absorbed by the refrigerant. However, in case of HCFC's or HFC's the water vapour will be only partially absorbed by the refrigerant and the rest in the filter-drier elements. In the latter situation, blocking of the liquid-flow due to saturated drier-elements is a warning that too much air has entered the plant and corrective measures must be taken. In the case of ammonia plants this may not be noticed until severe problems arise. "Wet" ammonia is highly corrosive and drastically reduces the lifetime of components and accelerates decomposition of the lubricating oil. We recommend that the water content is measured at regular intervals and if it is greater than 0.3% by mass then the application of the Grasso Dryer should be considered

1. INSTALLATION AND PREPARATION FOR USE

1.1 GENERAL

The purger unit as per flow diagram (Fig. 1.1-1) is factory charged with 650 grams of R404A, adjusted, tested and ready to use as shipped. No special shipping protectors are used. This purger-unit is suitable for refrigeration plants with ammonia (R717) and all halocarbon refrigerants with a condenser pressure of at least 5 bar effective. The maximum ambient (air) temperature is +45 °C.



Protection class IP20; Outdoor use of the purger is NOT allowed.



The electrical parts of the purger are not explosion proof.



Keep the unit in an upright position to avoid damage to the compressor, and wait at least 12 hours before switching on the unit after installation.

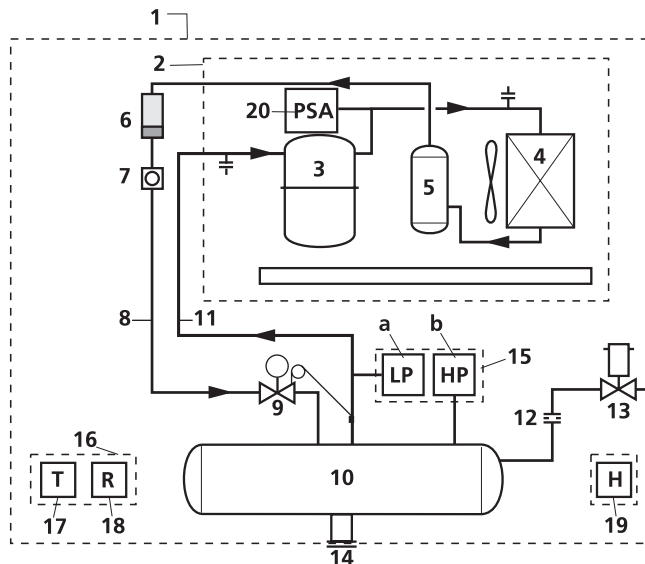

Fig. 1.1-1 Flow diagram (Refer Table 1.1-1/ Fig. 4.2-1)

Table 1.1-1

Legend Fig. 1.1-1	
1	Complete purger unit
2	Condensing unit:
3	Hermetic compressor
4	Air cooled condenser with fan
5	Liquid receiver
6	Filter/drier
7	Liquid sight glass
8	Liquid line from condensing unit
9	Thermostatic expansion valve (MOP type)
10	Heat exchanger (contains evaporator of condensing unit)
11	Suction line to condensing unit
12	Blow-off metering device (with built-in restriction =calibrated orifice) for non-condensable gases
13	Blow-off solenoid valve
14	Connecting flange (and separate counter flange) to connect inner space of heat exchanger vessel to refrigeration plant to be purged
15	Combined LP and HP pressure switch, used as control switches: a.LP section connected to suction line of condensing unit, thus activated by pressure in evaporator in heat exchanger. HP section connected to inner space of heat exchanger vessel, thus activated by condenser pressure of refrigeration plant to be purged
16	Main terminal box
17	Timer, mounted in terminal box, for switching condensing unit on and off
18	Auxiliary relay, mounted in terminal box, for opening and closing blow-off solenoid valve
19	Hours-run counter of effective purging time
20	HP safety switch limiter (R404A)

1.2 FACTORY SETTINGS



The settings of the unit are very crucial. Change of settings will severely restrict the performance of the unit. Refer to Section 4.1 to check factory settings.

1.3 MOUNTING THE UNIT

General

Always mount the purger in an exactly horizontal position on a sufficiently strong and rigid bracket or any other support by means of the 4 bolt holes \varnothing 10 mm, provided in the bottom of the purger base frame as indicated in the dimensioned sketch (Fig. 4.2-1)

Mounting Locations

In the sections below, 5 different locations for mounting the Grasso Purger are described

In case of mounting locations other than as described below, consult Grasso for additional instructions if required.

Mounting location drawings:

- 1 Single condenser system with open condensate line (refer Fig. 1.3-1, P1)
- 2 Single condenser system with liquid trap (refer Fig. 1.3-1, P2)
- 3 Multiple condenser system with HP floats (refer Fig. 1.3-2, P3)
- 4 Multiple condenser system with liquid traps, purger mounted ABOVE liquid level receiver (refer Fig. 1.3-2, P4)
- 5 Multiple condenser system with liquid traps, purger mounted BELOW liquid level of receiver (refer Fig. 1.3-2, P5)
- 6 Detail B (DB), important mounting detail for purge connection (refer Fig. 1.3-1/ Fig. 1.3-2, DB)

Mounting hints

1. For maintenance reasons it is recommended to mount an 8 mm or 3/8" ID venting stop valve on the purger inlet side as indicated by pos. 7. This valve is necessary to release the remaining refrigerant from the purger heat exchanger vessel after the isolating stop valve has been closed to enable the purger unit to be disconnected from the refrigeration plant.
2. Also for maintenance reasons make sure that, when mounting the purger near other objects or for example on a wall, enough space is left for unscrewing and removing the cover and to assure the accessibility of terminal box, pressure switches, etc. (Fig. 4.2-1).

1.3.1 MOLECULAR MASSES

At the same pressure non condensables (NC) (molmass air = 29) can be heavier or lighter than the refrigerant (Molmass NH₃ =17, molmass R404A = 97.6). In NH₃ systems the NC's will settle at the lowest spot of the condensing system whereas in halocarbon systems the NC's will remain at the top. In aircooled or evaporative condensers the gas velocity at the inlet is sufficiently high that air would be entrained. During condensing of the refrigerant the speed will be progressively reduced to zero at the outlet connection allowing air to be trapped in this position. During standstill, in halocarbon condensers, the air will flow back to the top from where it can also be purged.

1.3.2 DRAWING FIG. 1.3-1, P1

Only in case of a single condenser system, with an oversized (<0.3 m/s) condensate line to secure flash gas return to the condenser, a purger can be positioned on the receiver (refer Fig. 1.3-1, P1).



If NC's are lighter than the refrigerant, the purging unit will be effective only during plant stand still.

1.3.3 DRAWINGS FIG. 1.3-1 AND FIG. 1.3-2, P2 P3, P4, P5



The purger unit is connected via a solenoid valve E, as close as possible to the purge valve B.

In multiple condenser systems, liquid traps on the condenser outlets are often used to prevent filling up of condensers due to different pressure losses over the condensers.

These liquid traps are, when selected properly, filled with liquid refrigerant thus trapping non condensables in the condenser, so non condensables cannot reach the receiver when the plant is running.

Understanding this, every possible NC trap should be individually purged.

It is not allowed to make one common purge line as the pressures on the outlet of all condensers will be equalised, making the liquid traps useless.

Each purge valve has to be provided with a non servo working solenoid valve (e.g. Hansen HS6).

It should be installed close to the purge location, to prevent condensation in the purge line up stream.

The solenoid valves should be sequentially opened.



The "built-in" timer, therefore, should be bypassed by means of a potential free contact linked to an external 30 min. timer enabling it to start up simultaneously with the individual purge solenoid valves. In this way every purge point will be tested for non condensables immediately after activation even when the built in timer (24h) is not activated at the time. Depending on the amount of purge points the individual purge times can be chosen. The control for multipoint purging, including the external potential free contact, should be integrated in the overall plant system by the contractor.

Connections X3 and X5 of the terminal box should be used for the extra "bypass" contact (For more information see the electrical wiring diagram Section 4.3).

The purger must be positioned as high as the highest purge point and connected to the liquid side of the receiver, again to prevent pressure balancing of the individual condensers.

If the latter is unpractical, a condensate drain to the low pressure separator could be made, the position of the purger is then completely free of choice. In case of DX systems the purger condensate drain should be connected to one of the evaporator injections after the TEV. If this evaporator can be switched off, the purger condensate line should be switched off too.

1.3.4 GRAPHICS

Table 1.3-1 Legend for Fig. 1.3-1 and Fig. 1.3-2

Pos.	Description
1	Grasso Purger unit
2	Flanges
3	Liquid line from condenser(s)
4	HP liquid receiver
5	Liquid line to evaporator
6	Isolating stop valve
7	Venting stop valve
8	Condenser
9	Thermo syphon heat exchanger
10	Condensate drain (e.g. HP float Witt, HR1bw)
11	Heat recovery heat exchanger
12	Evaporator
13	Expansion valve (TEV)
A	Service purge valve (in case of non condensables being lighter (molmass<29) than refrigerant)
B	Service purge valve (in case of non condensables being heavier (molmass>29) than refrigerant); refer DB
B DB V	 Detail B (DB); NC vent line (B) has to be connected vertical(V) on top of horizontal condenser outlet (refer to figure DB).
C	To allow vapour to flow back to condenser Velocity liquid max. 0.3 m/s
D	Prevent heat load on liquid supply leg
E	Non servo controlled solenoid valve (e.g. Hansen HS-6 or Danfoss ERVA-3) to be fitted as close as possible to purge point (to prevent condensation in purge line) All piping and valves DN15. Each solenoid valve has to be sequentially opened.
F	Purger to be installed above condenser/HP float outlets
R	Roof
M	Machine room
!	Liquid trap

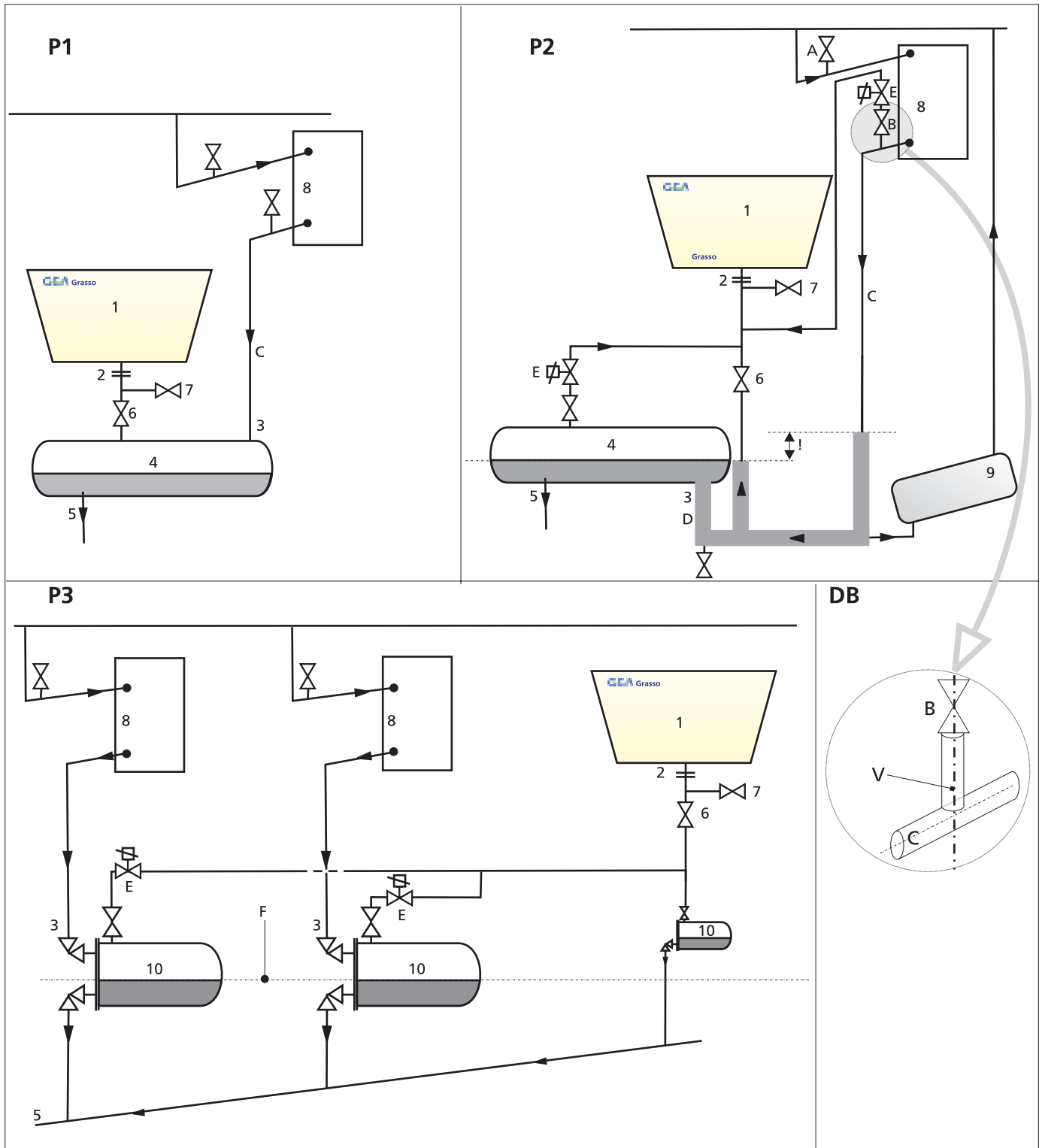

Fig. 1.3-1 P1, P2, DB, refer "Mounting location drawings:" on Page 10 and Table 1.3-1

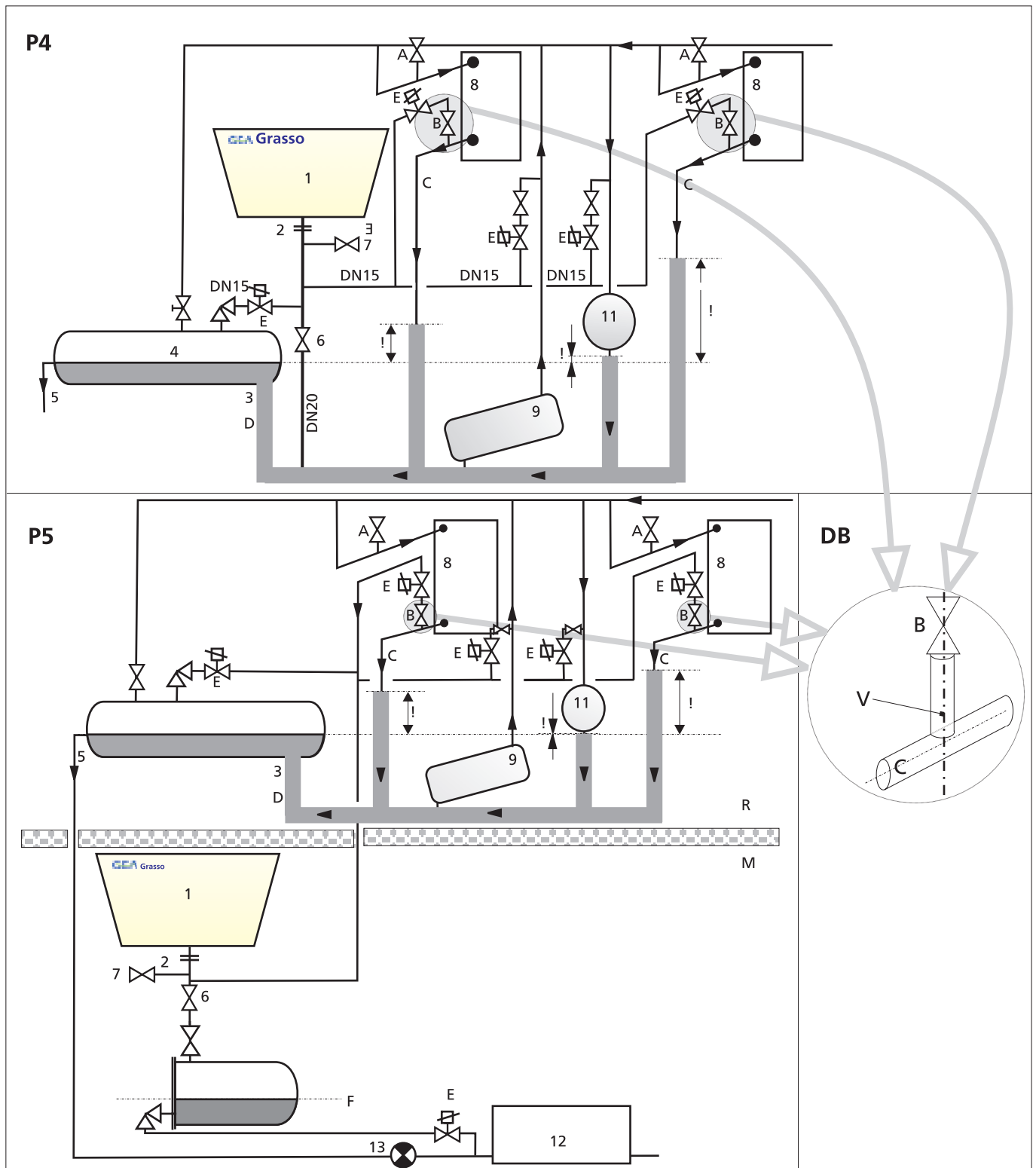

Fig. 1.3-2 P3, P5, P5, DB, refer "Mounting location drawings:" on Page 10 and Table 1.3-1

1.4 POWER CONNECTION



EN 60204 has to be taken into account before connecting main power supply.

Electric connections must be performed according to the following:

- Check if the voltage and frequency shown on the purger name plate (220-240V/50 or 60Hz) matches the local main supply.
- Refer Fig. 4.3-1 for the internal wiring diagram and terminal strip of the purger unit
- Synchronize the timer with the local clock time.

1.5 INSTALLATION CHECKLIST AND STARTING

Before applying current to the purger unit and thus starting it, the following points have to be checked:

1. Name plate voltage and frequency match the main supply.
2. Refrigerant lines are not rubbing.
3. The fan turns freely, the wheel and blades do not strike the housing.
4. Both the fan and the condenser coil are free of anything that would restrict a free air flow.
5. Cover is in place and secured.
6. In case the purger is placed indoor, the room has to be sufficiently ventilated.

Starting up



In new and large refrigerating plants, the purger may operate continuously for some weeks! This depends on the amount of non condensables in the system.

- a. Open all connecting valves to the refrigeration plant and plug in the unit.
- b. Depending on the timer position the condensing unit of the purger will run. The timer only starts this unit once a day. The minimum running/operating time is 30 minutes. After these 30 minutes, the low-pressure switch determines whether the condensing unit should continue to operate and the blow-off valve is to be opened. After some time the same switch will stop the purger auto-matically.
- c. If the condensing pressure of the plant is too low the HP- switch will stop the purger unit or prevent it from starting, irrespective of the timer position.

1.6 DISMOUNTING THE UNIT

For dismantling the purger unit the following should be done step-by-step, and in this order.

- 1 Shut off main power supply.
- 2 Remove all electrical connections from the exterior of the unit.
- 3 Shut off connecting stop valves to the plant.
- 4 Manually purge via the venting stop valve.
- 5 Disconnect the unit from the plant.
- 6 Remove the unit from its mounting.

2. INSPECTION, MAINTENANCE AND REPAIR

2.1 GENERAL

Inspection intervals for the purger unit cannot readily be determined since this depends very much on local conditions. Generally it is recommended to inspect and clean the condenser finned coil at least once a year.

2.2 INSPECTION

Performing an inspection, the following points should be carried out:

1. While the unit is running check for any abnormal sound. If abnormal sound is heard, locate where it is generated. Vibration may introduce rubbing lines or loose parts. Vibrations can be caused by unbalance in the fan, either by dust built up on the fan blades or by mechanical damage to these blades. In case of a noisy compressor reference should be made to the trouble shooting list (Section 3.2).
2. Thermostatic expansion valve;
 - a. Check sensor bulb and power element for external damage.
 - b. Check capillary tube for knicks. In case of occurrence replace power element assembly
 - c. Check sensor bulb for good contact with suction line.
3. Check refrigerant lines for knicks.
4. Check condenser coil for damaged fins and dust collected on outer surface. Clean if necessary.
5. Check liquid flow in sight glass.
6. Check blow-off solenoid valve for being activated (opened) when the unit is running longer than 30 minutes and check purger outlet line for gas flow. Refrigeration practice is to extend the purge line with a plastic or rubber hose and let the hose end in water. Gas bubbles indicate a gas flow. We think this is standard practice and needs no further clarification.
7. Check fan for excessive dust built up and mechanical distortion. Clean if required. Replace if damaged.
8. Inspect condenser inlet and outlet grilles for free air flow.
9. Check cover to be in place and secured.
10. Check all mounting bolts to be tight. Generally, if these points prove to be satisfactory, further maintenance and/or inspection is not required. If there is any doubt about the satisfactory running of the purger unit, the following checks can be performed.
11. Check with a gauge manifold whether the suction pressure of the condensing unit complies with -24 °C or less.
12. Check amperage of compressor and fan motor.

If these points meet the requirements mentioned, no further inspection is required.



The LP pressure switch (Fig. 1.1-1, item 15a) has a pure controlling function and is not meant as a low pressure protection for the compressor. Therefore, the contact of this switch is not opened (as usual), but closed at falling pressure.

2.3 REPAIR

For most components of the purger field repairs or adjustments are not required. In cases parts can not be repaired at all, consult Grasso for advise. For major component replacement it is advised to replace the entire unit.

2.3.1 DISASSEMBLY OF FAN MOTOR

1. Disconnect all electric power.
2. Remove cover.
3. Open terminal box and disconnect fan motor leads. Mark connections for reassembly.
4. Pull leads from terminal box.
5. Dismount fan motor assy and repair if necessary.

When reassembling the fan assembly, make sure that the fan motor leads are properly connected electrically. Improperly connected, the motor or the capacitor or both may be destroyed.

3. TROUBLE SHOOTING

3.1 GENERAL

In case the inspection requirements according to Chapter 4 are not met, trouble shooting and repair or correction should be performed.

3.2 DIAGNOSIS TABLE

Table 3.2-1

	Condition	Probable cause	Remedy
1	Suction pressure abnormally low, discharge pressure normal	Moisture frozen in expansion valve	Defrost valve and evacuate on refill system
		Shortage of refrigerant	Find and repair leak. Add refrigerant
		Restricted suction line	Repair line
		Expansion line defective	Replace expansion valve
2	Suction pressure drops rapidly just after compressor starts	Expansion valve lost its charge. If the expansion valve capillary tube breaks and loses its charge of gas, the valve will close, and causes the suction pressure to be low	To test, loosen bulb and warm in hand. Valve will remain closed and compressor will operate in vacuum. Replace expansion valve if necessary
		Obstruction in the expansion valve or valve may be stuck closed. May be clogged by ice, wax or dirt. Wrong expansion valve	Clean or replace expansion valve. Evacuate and recharge the system
3	Suction pressure rises rapidly on the OFF cycle. Refrigeration capacity is reduced	This indicates leaking, worn or broken discharge valve plates	Contact Grasso - Service Dept.
4.1	 Signal lamp "High pressure" is on. (Fig. 4.3-1, pos. 7)	Refer to 4.2 below	Refer to 4.2 below. Reset HP Pressure safety switch limiter (locking device with external reset) (Fig. 4.3-1, pos. 6).
	High discharge pressure. Suction pressure normal		Check setting of HP pressure safety switch limiter (Fig. 4.3-1, pos. 6)
4.2	High discharge pressure. Suction pressure normal	Air or other non-condensable gases in system. Allow unit to come to ambient temperature, if discharge pressure is more than 100 kPa above the pressure corresponding to the ambient air temperature	Dump charge (using e.g. a vacuum tank), evacuate and recharge
		Restriction in line leading from the compressor, through the condenser, to the automatic expansion valve will cause high discharge pressure	Remove obstruction
		Air in the system	Dump charge (using e.g. a vacuum tank), evacuate and recharge
		Overcharge of refrigerant	Check charge and remove refrigerant as necessary
		Condenser fan out of order	Replace fan or fan motor
		Fan not positioned properly in spinning	Slide fan on shaft to proper position. Tighten lock screw securely
		Dirty condenser	Clean condenser
Restricted line before condenser	Repair line		
5	Discharge pressure low. Suction pressure normal or high	Compressor stuck, open or leaking	Contact Grasso - Service Dept.
6	Compressor crankcase is cold and may sweat	Expansion valve stuck in open position. Due often to loose bulb which is not properly clamped to the suction line	Fasten bulb properly. Adjust and/or replace valve as necessary (Fig. 1.1-1, pos. 9)
		Possible pressure of liquid slugging is indicated by cold crankcase	Repair or replace expansion valve if stuck in open position and bulb is not loose
		Overcharge of refrigerant	Check charge and remove refrigerant as necessary

	Condition	Probable cause	Remedy
7	Suction line too cold or frosted	Expansion valve stuck open	Repair or replace expansion valve
		Expansion valve open too far	Adjust expansion valve (Fig. 1.1-1, pos. 9)
8	Suction line is warm	Insufficient refrigerant passing the expansion valve. Could be an obstruction in the expansion valve, valve stuck closed or clogged by ice, wax or dirt	Replace valve or remove obstruction
9	Certain points in liquid line cold, or may sweat or frost. Evaporator coil and suction line warm	Obstruction in suction line, flow or refrigerant slowed or stopped	Determine location (where line first gets cold). Remove obstruction
10	Noisy compressor, pressure normal	Compressor bearings worn	Contact Grasso - Service Dept.
		Loose mounting bolts	Tighten bolts
		Worn pistons, worn or broken valve or worn bearings	Contact Grasso - Service Dept.
11	Noisy compressor, discharge pressure high	Noisy operation can occur when discharge pressures are extreme It may also be caused by the presence of air or other non-condensable gases in the system	Dump charge (using e.g. a vacuum tank) Evacuate and recharge
		Overcharge of refrigerant	Dump part of charge (using e.g. a vacuum tank)
12	Noisy compressor, suction line frosted	Expansion valve bulb not firmly attached to suction line	Attache expansion valve bulb properly
		Superheat set too low	Reset superheat on expansion valve
		Expansion valve stuck open	Repair or replace expansion valve
13	Noisy compressor, discharge pressure high. Sudden reduction of suction	Expansion valve sticking in closed position	Repair or replace expansion valve
14	Pressure will cause oil slugging as refrigerant rapidly boils out of oil	Formation of ice due to moisture in system	Dehydrate the system, then recharge
		Formation of wax at valve	Dump charge using e.g. a vacuum tank. Circulate R404A cleaner refrigerant, evacuate, recharge
15	Noisy compressor, sufficient refrigerant, high suction pressure, lack of compression	Leaking, worn or broken piston head valve	Contact Grasso - Service Dept.
16	Noisy compressor, suction pressure high, discharge pressure low	Broken valve	Contact Grasso - Service Dept.

4. MISCELLANEOUS

4.1 TECHNICAL SPECIFICATIONS AND SETTINGS

Notified Body
RWTUV, CE0044

Regulations

The Grasso Self-Limiting Automatic Purger will be delivered according to the following directives and standards:

1. Pressure equipment directive
2. Machine directive
3. Low voltage directive
4. EN 60 335-1, EN 60 335-2-40, EN 60 204, EN 294, EN 292, EN 378

Table 4.1-1 Technical details AIR PURGER, PATENT 87-2015177

Technical specifications		
1	Dimensions:	
	Lenght	Above 700 mm
		Below 500 mm
	Height	450 mm
	Width	330 mm
	Mass (Weight)	Approx. 50 kg
2	R404A charge	0.65 kg
3	Connection power	400 W (Compressor 335 W, fan 50 W, valve coil 10 W)
4	Starting current	12 A (Nominal: compressor 2.1 A, fan 0.26 A)
5	Sound pressure level (SPL)	54 db(A)
6	Max. operating pressure	25.0 bar
7	Test pressure heat exchanger (shell /tube)	35.75 / 35.75 bar
8	Voltage/Frequency	230 V/50 or 60 Hz
9	Max./Min ambient temperature	+ 45 °C/ -15°C
10	Connection to plant	Flange for pipe 22 mm = 7/8" ID
11	Volume heat exchanger (shell/tube)	3.45/0.075 liter
12	Operating temperature heat exchanger shell	-40 / -50 °C

Table 4.1-2 Settings

	Subject	Value	Refs
1	LP-switch	210 kPa (= 2.1 bar abs.), dif 50 kPa (= 0.5 bar) (R404A)	Fig. 1.1-1, pos 15a Fig. 4.2-1, pos 11 Fig. 4.3-1, pos 4
2	HP-switch	600 kPa (= 6 bar abs.), dif 300 kPa (= 3 bar)	Fig. 1.1-1, pos 15b Fig. 4.2-1, pos 11 Fig. 4.3-1, pos 3
3	HP-switch limiter	25 bar (e)	Fig. 1.1-1, pos 20 Fig. 4.3-1, pos 6
4	CP-switch (condensing pressure), fan control	Cut in 1600 kPa (16.0 bar abs), diff. 100 kPa (1.0 bar) Cut out 1300 kPa (13.0 bar abs), diff. 150 kPa (1.5 bar)	Fig. 4.3-1, pos 10
5	Timer	30 minutes run per 24 hours	Fig. 1.1-1, pos 17 Fig. 4.3-1, pos 1

GEA Grasso
Grasso Products B.V., 's-Hertogenbosch, The Netherlands

GRASSO PURGER		PATENT 87-2015177	
		50	kg
230	v		Hz
		400	w
t_{co} min/max	-15/45 °C	IP20	
Shell		Tube	
v	R717 R22	3.45	l
v	R404A	0.075	l
PT	35.75	PT	35.75
PS	25	PS	25
t_s min/max	-40/50 °C	R404A	0.650
CE 0044			

Fig. 4.1-1 Type plate

4.2 EXPLODED VIEW AND DIMENSIONED SKETCH

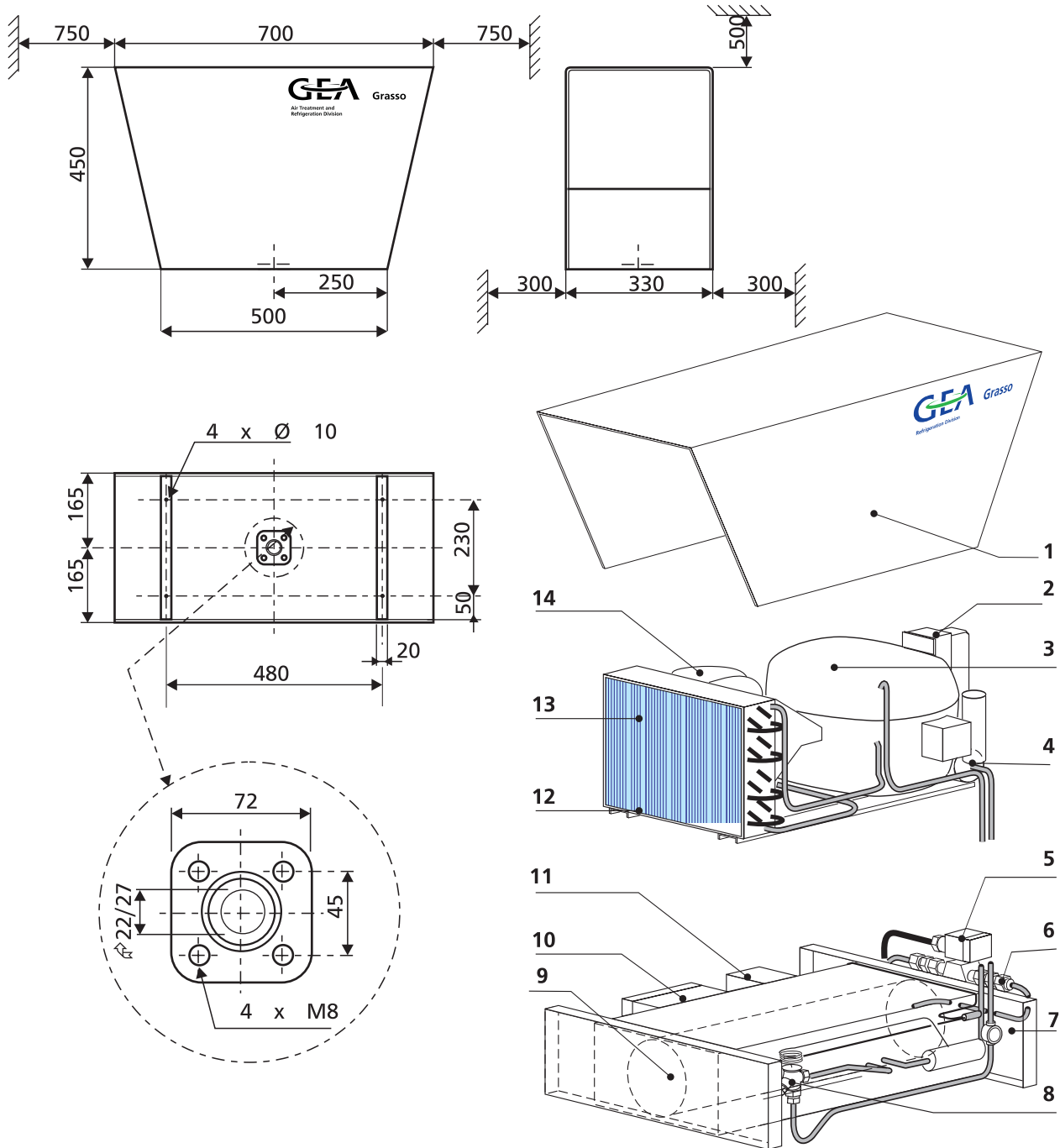

Fig. 4.2-1 Exploded view and dimensioned sketch (refer Table 4.2-1)

Table 4.2-1

Legend Fig. 4.2-1	
1	Cover
2	Hours-run counter of effective purging time
3	Hermetic compressor
4	Filter/drier
5	Blow-off solenoid valve
6	Blow-off metering device
7	Steel base frame
8	Thermostatic expansion valve
9	Foam insulated heat exchanger
10	Main terminal box with timer and auxiliary relay
11	Combined LP/HP pressure switch
12	Condensing unit
13	Air cooled condenser
15	Liquid receiver

4.3 WIRING DIAGRAM

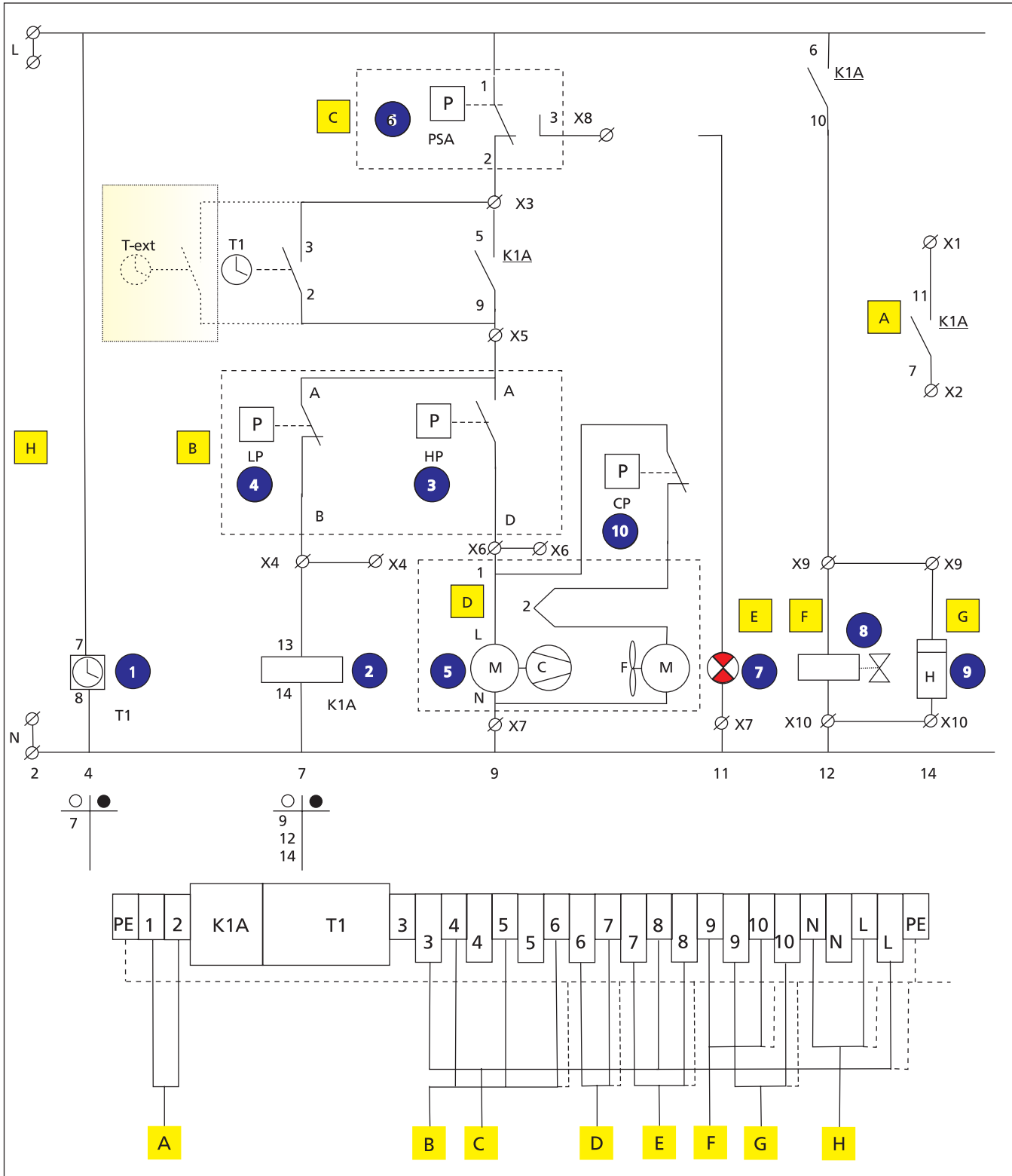



Fig. 4.3-1 Electrical wiring schematic (Refer Table 4.3-1)

Table 4.3-1 Electrical wiring schematic (Fig. 4.3-1)

Legend	
A	Free contact
B	LP/HP safety switch (3/4)
C	HP safety switch limiter (6)
D	Condensing unit (5)
E	Warning light (7)
F	Purge valve (8)
G	Hours counter (9)
H	Power supply, 3 x 1.5 mm ²
T-ext	External time relay; In case of multi point purging, an external time relay is required to bridge terminal X3 and X5; 
	External time relay is not included.
	Closes contact after every purging point switch for 30 minutes.
1	Timer (Fig. 1.1-1, pos. 17)
	Closes contact every 24 hours for 30 minutes.
2	Auxiliary relays (Fig. 1.1-1, pos 18)
3	HP pressure switch (Fig. 1.1-1, pos 15b)
	Opens contacts in case of falling pressure at 600 kPa(a)
	Closes contacts in case of rising pressure at 900 kPa(a)
4	LP pressure switch (Fig. 1.1-1, pos. 15a)
	Closes contacts in case of falling pressure at 210 kPa(a) (R404A/-30 °C)
	Opens contacts in case of rising pressure at 260 kPa(a) (R404A/-24 °C)
5	Condensing unit (Fig. 1.1-1, pos 3 + 4)
6	HP pressure safety switch limiter (Fig. 1.1-1, pos 20)
7	Signal lamp "High Pressure"
8	Blow-off solenoid valve (Fig. 1.1-1, pos. 13)
9	Hours counter
10	Condensing pressure safety switch; Fan control; in case of low condensing pressure, the fan will be switched off (refer Table 4.1-2)

Grasso Products b.v. • Parallelweg 27 • P.O. Box 343 • 5201 AH 's-Hertogenbosch • The Netherlands
Phone: +31 (0)73 - 6203 911 • Fax: +31 (0)73 - 6214 320 • E-Mail: products@grasso.nl

Grasso GmbH Refrigeration Technology • Holzhauser Straße 165 • 13509 Berlin • Germany
Phone: +49 (0)30 - 43 592 6 • Fax: +49 (0)30 - 43 592 777 • E-Mail: info@grasso.de



Find out more
on our homepage
www.grasso-global.com



GEA Grasso

Refrigeration Division

A company of GEA Group

Please contact your office: