



TRANE™

CGAE 102-207

Liquid chillers, air cooled



- Nominal cooling capacities 52 to 157 kW. 6 sizes
- With Trane 3-D scroll compressors
- Microprocessor-based leaving chilled water PID temperature control
- Extensive remote control and communication capabilities
- Factory run tested
- Designed and manufactured in accordance with the Trane Quality Management System approved to BS 5750, Part 1



QUALITY ASSURANCE



APPROVALS
B.S. 5750Pt1
ISO 9001
NEN 2646

C10 CA 001 E

Scroll compressor liquid chillers, air cooled
CGAE 102-207. 52 to 157 kW (50 Hz)

Trane 3-D scroll compressor

THE MOST advanced compressor technology available. Unmatched reliability through 64% fewer parts and 70% less torque variation than reciprocating compressors as well as an unsurpassed resistance to liquid slugging.

Simple Design with 64% Fewer Parts

Fewer parts than an equal capacity reciprocating compressor means significant reliability and efficiency benefits. The single orbiting scroll eliminates the need for pistons, connecting rods, wrist pins and valves. Fewer moving parts, less rotating mass and less internal friction means greater efficiency than reciprocating compressors, too. And the scroll compressor has been proven reliable in one of the most rigorous test programs in the air conditioning industry.

Low torque Variation

The 3-D scroll compressor has a very smooth compression cycle with torque variations only 30% of a reciprocating compressor. This means the scroll compressor imposes very little stress on the motor for greater reliability. Low torque variation results in less noise and vibration, too. Inherently smooth 3-D scroll compressor operation allows the use of industrial solid motor mounts rather than less reliable spring mounts required in many reciprocating compressors.

Exclusive Electronic Protection

Advanced microelectronics protect the compressor motor. The protection system monitors compressor suction and discharge temperature and motor temperature. Also protects against current overload, phase loss and phase reversal.

Suction Gas Cooled Motor

Compressor motor efficiency and reliability is further optimized with this design. Cool suction gas keeps the motor cooler for longer life and better efficiency than compressors with the motor located in the hot gas discharge.

Patented 3-D Scroll Compliance

Trane 3-D scroll compliance provides important reliability and efficiency benefits. 3-D compliance allows the orbiting scrolls to touch in all three dimensions, forming a completely enclosed compressor chamber. In addition 3-D compliance means the orbiting scrolls only touch with enough force to create the seal so there is no wear between the scroll plates. Since the compression chamber is completely enclosed, the scroll compressor achieves high efficiencies.

The most outstanding feature of the scroll compressor 3-D compliance is that the compressor «gives» to allow liquid or dirt to pass through without damaging the compressor. In a reciprocating compressor, however, the liquid or dirt has no place to go and can cause serious damage.

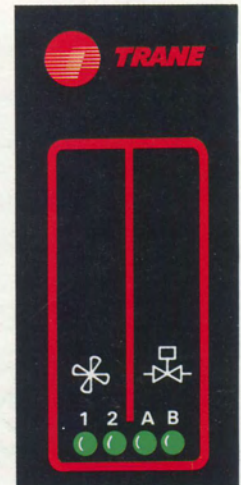

Fan and HGBP modul

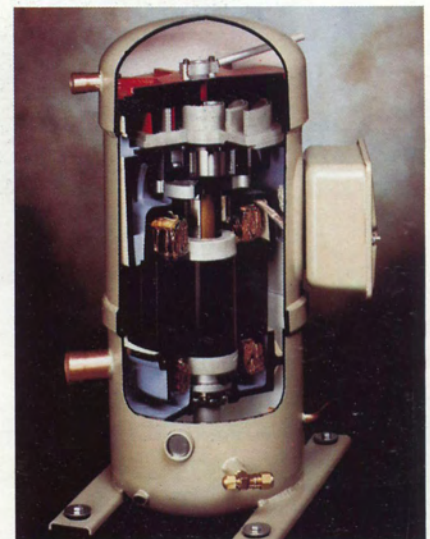
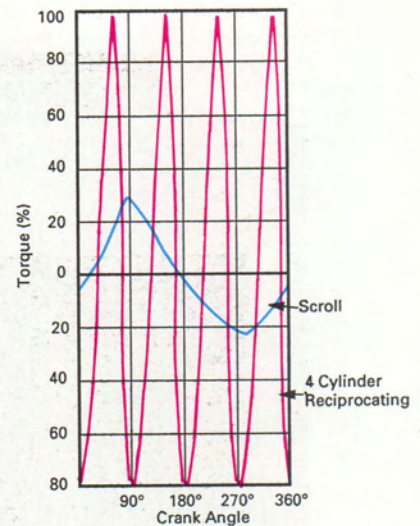

SCM Microprocessor control system :

Precise PID-type leaving chilled water temperature control, advanced operating mode control and system protection, extensive remote control and communication capabilities.

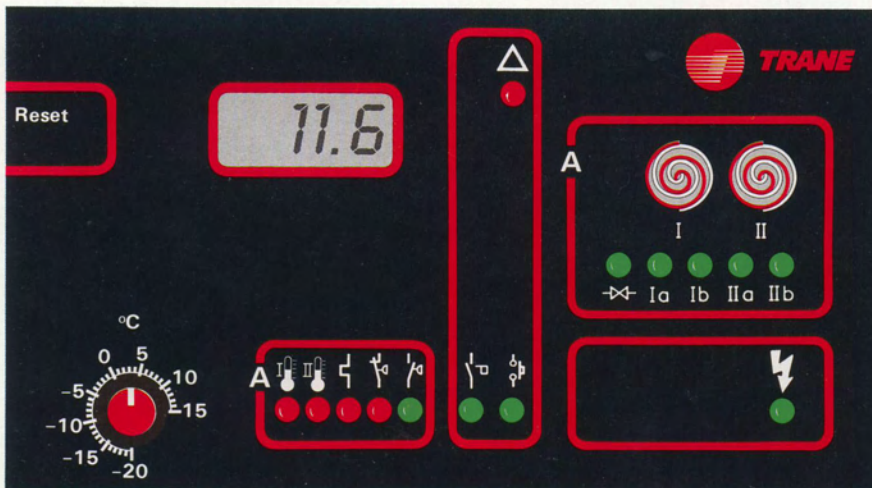

Central Control Module

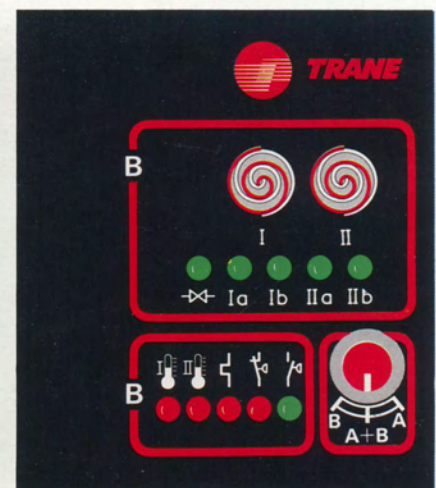

Dual circuit Module
(CGAE 205 - 206 - 207)

Microprocessor based chilled water control

The SCM controls from the leaving or supply water side of the chiller. With this temperature as a component of input, its programmed logic establishes the appropriate control response needed to produce a stable and accurate leaving water temperature condition. PID control produces accurate, responsive control action, eliminating steady state error from the chiller leaving water temperature.

Operating mode control

Programmed, «intelligent» multi-parameter operating mode control assures safe and continuous operation even at marginal operating conditions.

Operating mode control includes :

- Anti-recycle timing between compressor starts, capacity steps and circuits.
- Low pressure start logic.
- Automatic restart after a power loss.
- Operating time balancing of compressors.

System protection

All safety parameters are automatically checked before the chiller is allowed to start and also periodically during operation. The SCM system includes an auto-diagnostic routine which also covers the sensors.

The essential safety parameters are :

- Evaporator pressure
- Condensing pressure
- Discharge temperature
- Motor winding temperature
- Leaving chilled water temperature
- Motor current

Communication

The SCM system offers as standard different possibilities and levels of communication and remote control thus providing complete status information and simplified fault diagnostic.

Operator interface

A four-digit liquid cristal display on the front cover indicates the actual leaving chilled water temperature and the set point temperature. In case of an operational problem, 17 different fault diagnostic codes can be displayed indicating precisely the nature of the problem. The display further indicates operating hours and number of compressor starts.

LED indicating lights on the front cover provide detailed operating status information and the input status of the major safety devices.

Parallel mode communication and remote control

The SCM accepts the following input from a remote location and

thus allows remote control of the chiller :

- On/off control by means of a volt-free contact,
- Remote reset of the chilled water temperature set point with a 0 to 10 Volt signal.

Optional relay cards -one per circuit- provide volt-free contacts for remote status and failure indication.

Serial communication and remote control

The SCM is fitted as standard with a serial communication part which allows the chiller to communicate in the binary mode and to be integrated into a computerized Building Management system.

The SCM is a «slave system» controlled from a higher level system which can send the following commands via the serial link :

- Start/stop the chiller
- Change of chilled water set point.

The higher level system can also extract from the SCM operating and status information as well as coded diagnostic and fault indication. The information obtained through the serial communication link can be displayed on the screen of a computer or monitor.

Cooling capacities and compressor power input (50 Hz)

Model CGAE	Leaving chilled water temp. (°C)	Condenser entering air temperature (°C)									
		25		30		32		35		40	
		Cooling capacity kW	Comp. input kW	Cooling capacity kW	Comp. input kW	Cooling capacity kW	Comp. input kW	Cooling capacity kW	Comp. input kW	Cooling capacity kW	Comp. input kW
102	5	53.0	14.7	50.4	16.1	49.4	16.8	47.8	17.7	45.1	19.5
	7	56.0	15.0	53.4	16.5	52.3	17.1	50.6	18.0	47.8	19.9
	9	59.1	15.3	56.4	16.8	55.2	17.4	53.5	18.4	50.6	20.3
103	5	63.6	17.8	60.7	19.7	59.5	20.4	57.6	21.7	54.4	23.8
	7	67.1	18.2	64.1	20.1	62.8	20.8	60.9	22.1	57.5	24.2
	9	70.8	18.6	67.6	20.5	66.2	21.3	64.2	22.4	60.7	24.7
104	5	79.1	22.1	75.6	24.4	74.1	25.4	71.8	26.9	67.8	29.5
	7	83.5	22.6	79.8	24.9	78.3	25.9	75.9	27.4	71.7	30.1
	9	88.0	23.1	84.2	25.4	82.6	26.5	80.1	27.9	75.7	30.7
205	5	100.5	28.5	95.7	31.4	93.7	32.6	90.7	34.6	85.5	38.0
	7	106.0	29.1	101.1	32.0	99.0	33.2	95.9	35.3	90.5	38.8
	9	111.7	29.7	106.6	32.6	104.4	34.0	101.2	36.0	95.6	39.6
206	5	127.6	36.0	121.8	39.6	119.4	41.2	115.7	43.5	109.2	47.9
	7	134.8	36.7	128.7	40.4	126.2	41.9	122.3	44.4	115.5	48.8
	9	142.0	37.4	135.7	41.2	133.0	42.7	129.0	45.3	121.9	49.7
207	5	158.5	44.3	151.5	48.7	148.5	50.6	144.0	53.6	136.0	58.9
	7	167.4	45.2	160.0	49.7	156.9	51.6	152.2	54.7	143.9	60.1
	9	176.5	46.2	168.7	50.8	165.5	52.6	160.5	55.8	151.9	61.2

(1) Ratings are based on a fouling factor of 0.035 m²K/kW.

(2) Interpolation is permitted, extrapolation is not permitted.

Evaporator water side pressure drop

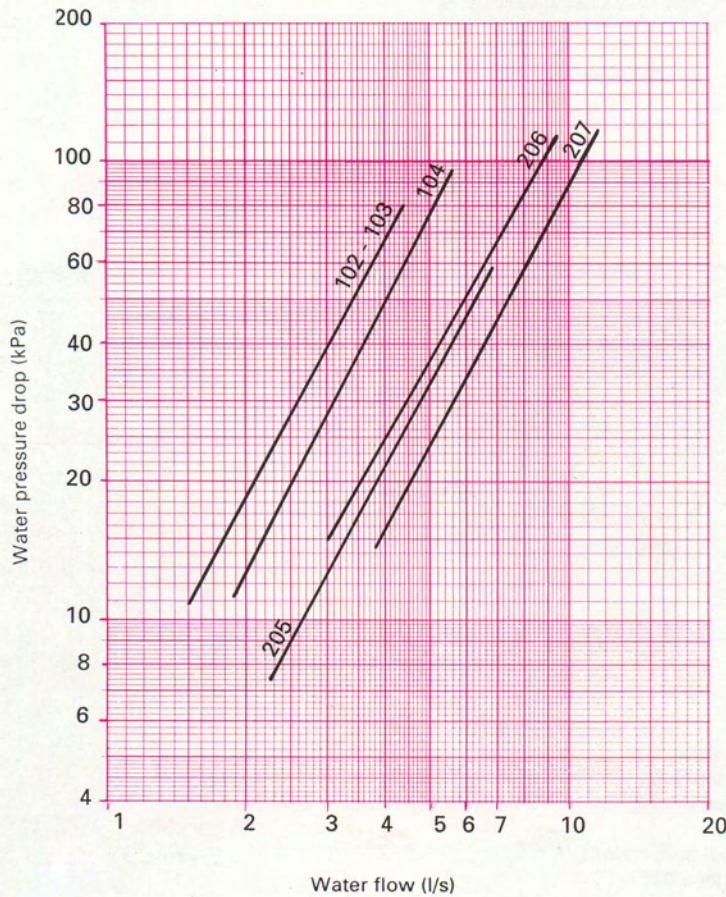

General data (50 Hz)

Model	CGAE	102	103	104	205	206	207
No of circuit(s) compressor(s) (1)	—	2/1	2/1	2/1	4/2	4/2	4/2
Capacity steps	%	50	58 or 42	50	75-50-25	80-50-21 70-50-29	75-50-25
Rated load current (2)	A	35	44	53	70	88	106
Inrush current (3)	A	111	155	164	146	199	217
Fan motor size	kW	2x0.53	2x0.53	2x1.3	2x1.3	4x0.53	4x1.3
Fan speed	Rev/sec.	10.8	12.1	13.0	13.0	12.1	13.0
Evaporator water content	litre	45	45	40	62	66	95
R22 operating charge	kg	16	18	19	27	34	38
Unit operating weight	kg	750	860	920	1110	1380	1660

(1) One set of 2 manifolded compressors on sizes 102, 103, 104, 2 sets on sizes 205-206-207.

(2) At 415/3/50, 5 bar suction pressure, 25 bar discharge pressure.

(3) One or three compressors running, the last one starting.

Dimensions

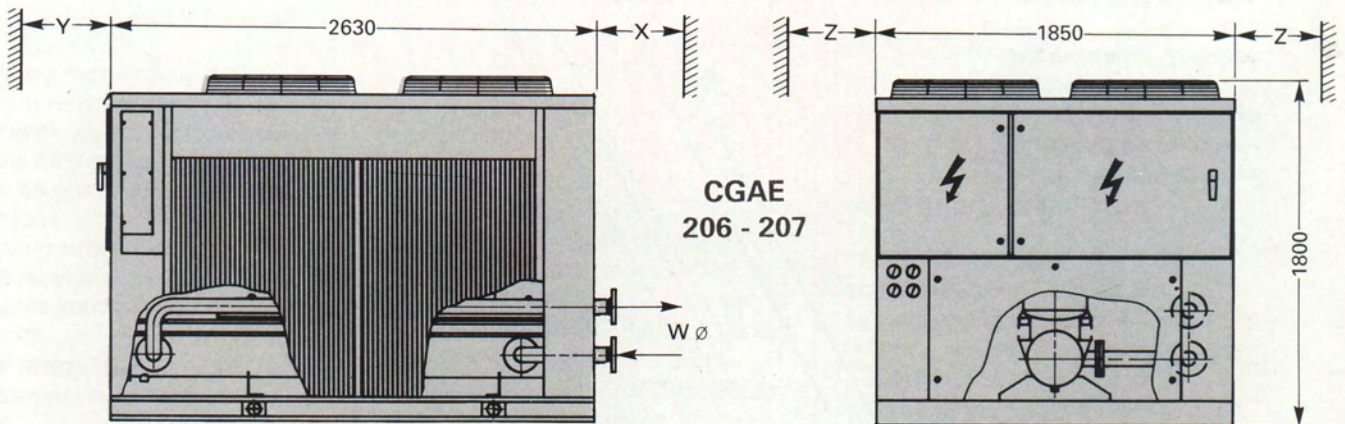
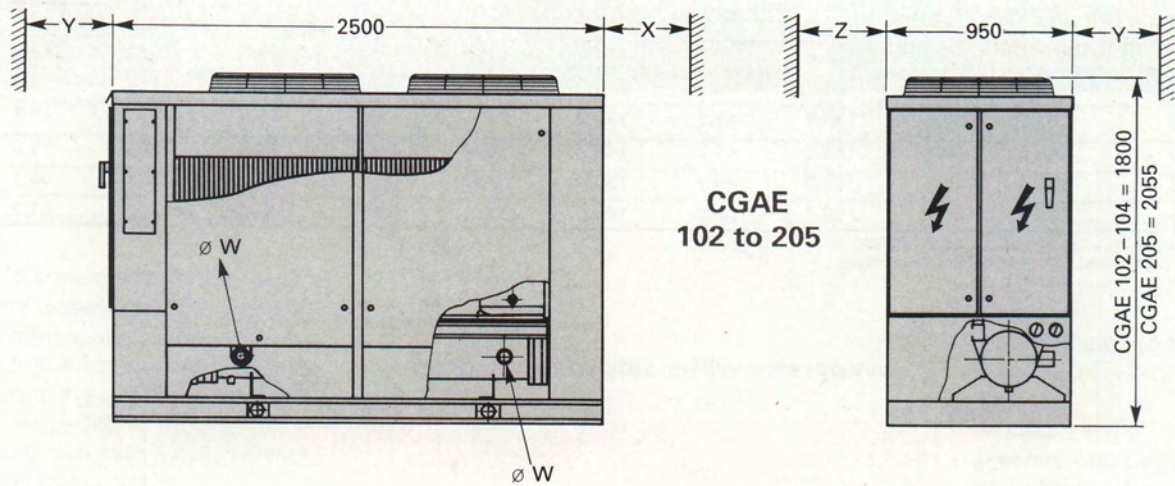

X = Minimum clearance for evaporator tube removal = 1700 mm

Y = Minimum clearance for maintenance = 800 mm

Z = Minimum clearance for air inlet = 2000 mm, between two machines = 3000 mm

ØW = Water piping connections :

CGAE 102-103 : 2" ISO R7 threaded connections

CGAE 104-206 : 2 1/2" (ND 65) flanges PN16

CGAE 207 : 3" (ND 80) flanges PN16

Dimensions approximate. Certified drawings upon request.

Mechanical specifications

Trane scroll compressor chiller units, factory assembled and wired, consisting of :

Scroll compressors

Hermetic, welded shell Trane 3-D scroll compressors. Axial and radial compliance of mating compression chamber surfaces through tip seals and swing link mechanism connecting the orbiting scroll to the motor shaft.

Swing link design to eliminate effects of liquid and oil slugging.

Lubrication with centrifugal oil pump, oil heater and sight glass.

Two-pole motor, suction gas cooled with solid state protection against excess temperature, overload.

Two manifolded compressors on unit sizes 102 to 104, four compressors on two independent circuits on unit sizes 205 to 207.

Condenser

One vertical air cooled condenser coil for CGAE 102 to 205, two vertical coils for CGAE 206 and 207. Two refrigerant circuits on CGAE 205, 206, 207.

Made of seamless copper tubes, expanded into continuous aluminium fins. Integral subcooler. Vertical discharge, direct drive propeller fans. Fan guards.

Evaporator

Shell-and-tube design, one refrigerant circuit on sizes 102 to 104, two separate circuits on sizes 205 to 207.

Refrigerant inside the tubes and water circulating in the shell ; steel shell welded to heavy steel tube sheets. Removable refrigerant heads.

Water connections male pipe thread ISO R7 on sizes 102 and 103, flanged on all other sizes.

Thermal insulation of evaporator of flexible closed cell polyvinylchloride.

Maximum operating pressure refrigerant side 1.6 MPa. Water side 1.4 MPa.

Refrigerant circuits

Each circuit including filter-dryer, sight glass, solenoid valve and thermostatic expansion valve. Compressor discharge service valve and liquid line shut-off solenoid valve.

Refrigerant circuit factory pressure and leak tested, dehydrated and charged with refrigerant charge.

Control and starter panel

Panel with separate compartments for motor starters and controls.

Starter panel section includes :

- Compressor motor contactors
- Fan motor contactors
- Overload relays
- Terminal strips

The control panel includes :

SCM microprocessor-based control system, providing :

- PID leaving chilled water temperature control
- Programmed operating mode control and system protection
- Parallel and serial remote control and communication capabilities

The SCM system further provides :

- Liquid cristal display of chilled water temperature, set point and 17 fault diagnostic codes
- LED's for indication of operating status and safety inputs
- Digital readout of operating hours and compressor start count
- Remote reset of chilled water temperature with 0-10 V signal
- Volt-free contacts (optional) for remote status and fault indication
- Serial communication port (TTY link) for binary communication and remote control

The control section of the panel further includes :

- HP, LP pressostats
- Terminal strips

Low pressure and high pressure gauges are provided outside of the panel.

Accessories and options

- Spring isolators
- Disconnect switch
- Factory-installed hot gas bypass
- Low ambient version
- High ambient version
- Condenser copper fins
- Relay cards

Factory testing

All CGAE chillers are fully run tested before shipment. Unit operation and all controls are thoroughly checked.

Shipment

CGAE ship on or wooden skid with the refrigerant and oil operating charge.

Quality assurance

The Quality Management System applied by Trane has been subject to independent third party assessment and approval to BS 5750 Part 1, I.S.O. 9001, and N.E.N. 2646. The products described in this catalogue are designed, manufactured, and tested in accordance with the approved system requirements as defined in the Trane Quality Manual.



TRANE™

Subject to modifications.

Sales offices in United Kingdom and Eire

Birmingham

24, New John Street West,
Newtown, Birmingham B19 3NB
Phone : (021) 359 6354 - Telex : 336 995 G
Fax : (21) 3598370

Bristol

Dockgate House,
151 Hotwell Road,
Hotwells
Bristol BS8 4RU
Phone : (272) 29 77 61 - Telex : 44 241 G
Fax : (272) 21 45 74

Dublin

8, The Mall
Lucan, co Dublin, Ireland
Phone : (1) 28.29.65 - Telex : 31 082 EI

Glasgow

10 Napier Court, Wardpark North
Cumbernauld G68 OLG
Phone : (02367) 36927 - Telex : 779 361 G
Fax : (2367) 36929

London

162 Windmill Road West
Sunbury-on-Thames TW16 7HB
Phone : (0932) 780 321 - Telex : 927 357 G
Fax : (0932) 765938

Manchester

Enterprise Trading Estate, Guinness Road,
Trafford Park - Manchester M17 1SD
Phone : (061) 848 0491 - Telex : 973400 ONECOM G
Fax : (61) 873 7303

Newcastle

218 Rothbury Terrace, Heaton
Newcastle upon Tyne NE6 5DF
Phone : (091) 276 2000 - Telex : 537 259 G
Fax : (91) 276 2933

Nottingham

60 Lenton Boulevard
Nottingham NG7 2EN
Phone : (0602) 41 22 12 - Telex : 377 552 G

C10 CA 001 E - 0289