



30HT,HQ,HW 043-280 30HZ,HZ"P",HZ"V" 043-280

Liquid chillers and heat pumps

50 Hz

PRO-DIALOG 721S
CONTROL



Installation, operation and maintenance instructions

QUALITY ASSURANCE
SYSTEM



CONTENTS

	Page
Start-up checklist	3
Dimensions/clearances	4
Technical/electrical data	6
Application data	8
Maximum chilled water flow	8
Water loop volume	8
Condenser water flow rates	8
Condenser water flow restrictor	8
Installation	9
Safety considerations	9
Preliminary checks	9
Moving and siting the unit	9
Check compressor mountings	9
Water connections	10
Condenser connections	10
Freeze protection	10
Installation of units with remote condensers	11
Power supply	11
Electrical checks	11
Start-up	11
Preliminary checks	11
Actual start-up	12
High pressure switch control	12
Servicing refrigeration components	12
General maintenance	12
Liquid refrigerant charging	12
Compressors	13
Heat exchangers	14
Troubleshooting chart	16

The photo on the front cover is only for illustration purposes and not contractually binding (photo shows unit with optional compressor sound enclosure).

The manufacturer reserves the right to make modifications at any time without prior notice.

START-UP CHECK LIST

Equipment sold by: _____

Installed by: _____

Site address: _____

Equipment type and serial numbers: _____

Start-up date: _____

Refrigerant: _____

Supply voltage: _____

Phase imbalance: Ph. 1 _____ V Ph. 2 _____ V Ph. 3 _____ V

Current draw: Ph. 1 _____ A Ph. 2 _____ A Ph. 3 _____ A

Main circuit breaker rating: _____ A

Control circuit voltage: _____ V

Control circuit fuse: _____ A

Condenser water entering temperature: _____ °C

Condenser water leaving temperature: _____ °C

Cooler water entering temperature: _____ °C

Cooler chilled water leaving temperature: _____ °C

Suction pressure: _____ kPa

Discharge pressure: _____ kPa

Control thermostat cut-out: _____ °C

Control thermostat cut-in: _____ °C

Safety thermostat cut-out: _____ °C

Low-pressure switch cut-out: _____ kPa

Low-pressure switch cut-in: _____ kPa

High-pressure switch cut-out: _____ kPa

High-pressure switch cut-in: _____ kPa

Pressure drop through cooler: _____ kPa

Pressure drop through condenser: _____ kPa

Oil level: _____

Oil visible in sight glass: _____

Colour of moisture indicator: _____

Air bubbles visible in sight glass: _____

Commissioning engineer (name): _____





Purchase order number: _____

Dimensions/clearances (mm)

30H*	A	B	C	D	E	F	G	H	J	K
Units with condenser										
043	2252	1370	915	1850	750	600	600	600	800	710
052-065	2550	1355	915	2200	750	600	600	600	800	710
091	2630	1915	950	2550	800	800	800	800	850	850
101-121	2940	1915	950	2500	800	800	800	800	850	900
141-161	3350	1915	950	2500	800	800	800	800	850	900
195-225	4255	1950	950	2150	800	800	800	800	850	900
250-280	4070	2000	1275	2750	1000	800	1000	800	950	900
Units without condenser										
043	2252	1110	905	1850	750	600	600	600	800	710
052-065	2550	1095	905	2200	750	600	600	600	800	710
091	2630	1300	950	2500	800	800	800	800	850	900
101-121	2950	1300	950	2500	800	800	800	800	850	900
141-161	3350	1300	950	2500	800	800	800	800	850	900
195-225	4255	1340	950	2150	800	800	800	800	850	900
250-280	4070	1680	1275	2750	1000	800	1000	800	950	900

All dimensions are given in mm

Legend:

-  Required clearances for maintenance
-  Power supply
-  Water inlet
-  Water outlet

* 30H 043 to 280 unit range (see front cover)

NOTE:
Certified dimensional drawings are available on request.
The drawings below are not contractually binding.

30H* 043-065

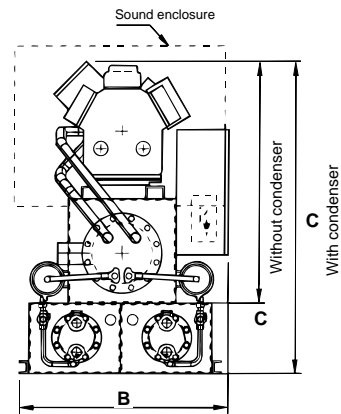
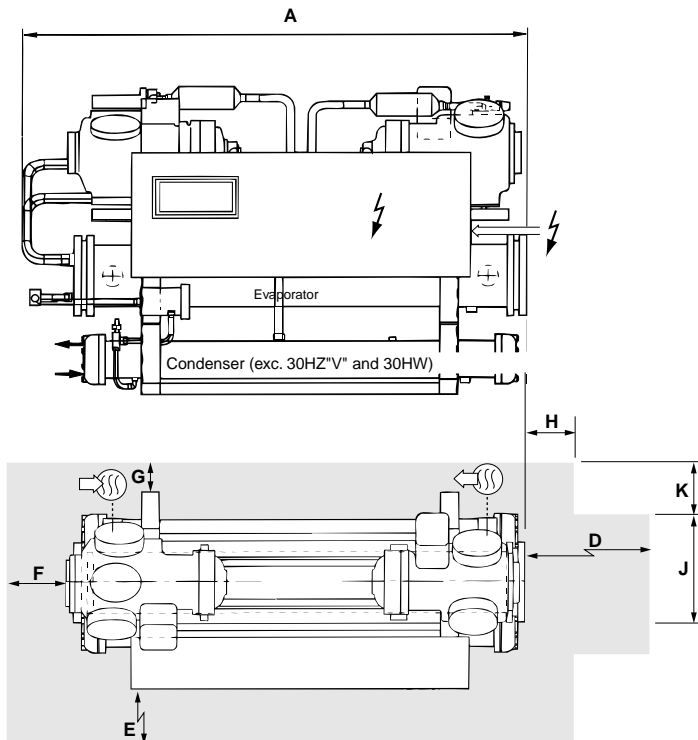

30H* 091-225

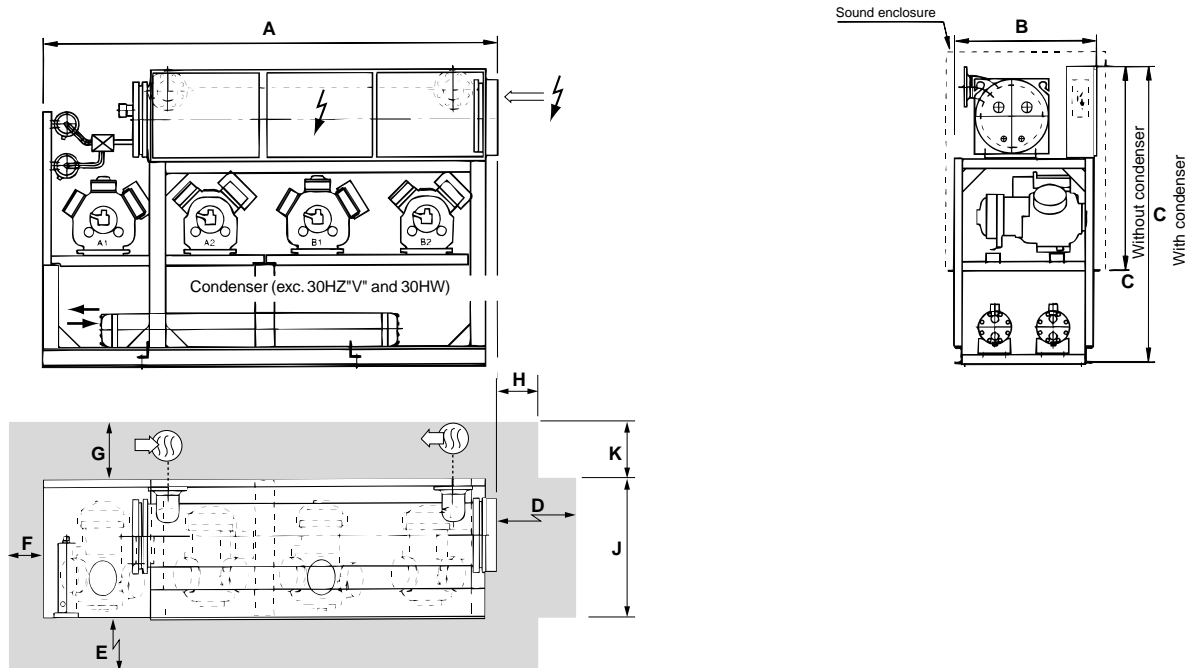

30H* 250-280

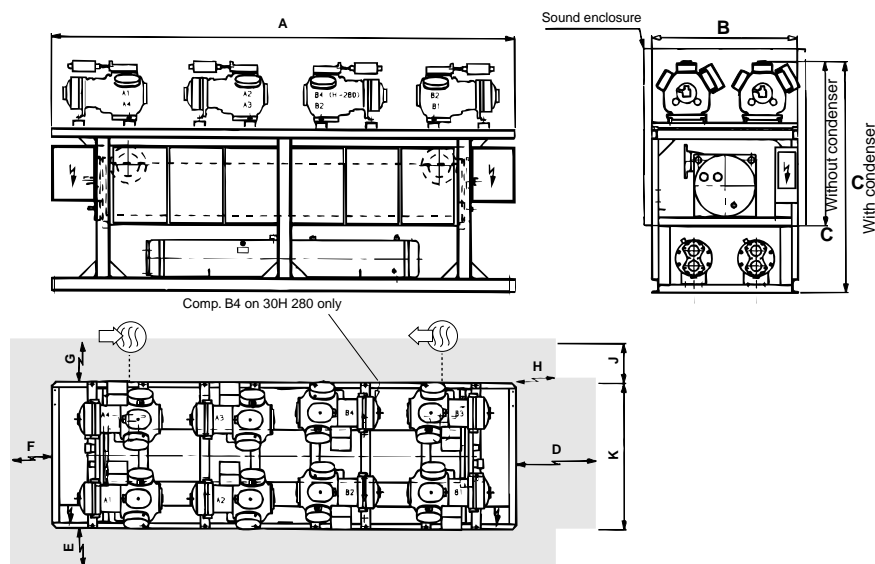

ATTENTION :
2 separate power supplies

Floor mounting

- For unit mounting holes, weight distribution and centre of gravity coordinates, refer to the dimensional drawings supplied with the unit.
- These units are designed for indoor installation.

Ambient temperature: 5-40°C
Max. relative humidity: 50% rh at a temperature of 40°C

PHYSICAL DATA

30H*		043	052	065	091	101	111	121	141	161	195	225	250	280
Net nominal cooling capacity**	kW													
Standard chiller 30HT**		144	166	215	250	292	323	342	402	447	578	677	779	847
30HW condenserless units***		136	157	208	234	280	300	321	380	417	538	633	729	792
Standard chiller 30HZ**		134	153	199	230	270	230	316	371	415	533	626	719	783
30HZ"V" condenserless units		126	144	194	216	260	278	297	351	388	500	588	677	735
Operating weight	kg													
30H (with condenser)		1075	1165	1232	2020	2350	2440	2490	2710	2810	3480	3780	4440	4870
30H (without condenser)		863	951	996	1650	1940	1980	2020	2240	2280	2950	3240	3750	4075
Refrigerant charge R407-C****	kg													
Circuit A		15.7	17.5	21	38.2	29.5	34.5	33.5	38	42	54	54	62.5	62.5
Circuit B		15.7	17.5	21	19.5	29.5	29.5	33.5	38	42	46.5	54	60.5	62.5
Refrigerant charge R22****	kg													
Circuit A		13.5	14	16.2	33.5	25.5	30	30	34	40	48	48	59	59
Circuit B		13.5	14	15.3	17.5	25.5	25.5	30	34	40	43.5	50	47	56
Compressors		Semi-hermetic, 4 or 6 cylinders 24.2 r/s (1450 rpm)												
Quantity - Circuit A		1	1	1	2	2	2	2	2	2	3	3	4	4
Quantity - Circuit B		1	1	1	1	2	2	2	2	2	2	3	3	4
Control type		PRO-DIALOG Plus												
No. of capacity steps		4	4	4	8	11	11	11	11	11	5	6	7	8
Minimum step capacity	%	40	33	33	22	20	18	16	19	16	20	16	14	12
Evaporator		Direct-expansion evaporator, one or two circuits, multi-tube shell												
Net water volume	l	55	63	63	92	154	154	154	199	199	242	242	276	276
No. of refrigerant circuits		2	2	2	2	2	2	2	2	2	2	2	2	2
Water connections:														
Inlet and outlet	Dia.	Threaded 3" gas			PN16 DN100		PN16 DN125		PN16 DN150					
Standard		NFE 03005			NFE 29203									
Drain	in	1/2" FPT												
Max. water side operating pressure	kPa	1000	1000	1000	1000	1000	1000	1000	1000	1000	1000	1000	1000	1000
Condenser		Shell and multi-tube type												
Quantity		2	2	2	2	2	2	2	2	2	2	2	2	2
Water volume	l													
Circuit A		10	10	12	25	18	25	25	25	30	37	37	51	51
Circuit B		10	10	12	12	18	18	25	25	30	37	37	37	51
Water connections:		Threaded gas			Flat flange, brazed									
Circuit A		1" 1/2		2"	2" 1/2	2"	2" 1/2	2" 1/2	2" 1/2	2" 1/2	3"	3"	3"	3"
Circuit B		1" 1/2		2"	2"	2"	2"	2" 1/2	2" 1/2	2" 1/2	2" 1/2	2" 1/2	2" 1/2	3"
Water box air vent	in	3/8 NPT												
Water box water drain	in	3/8 NPT												
Max. water side operating pressure	kPa	1000	1000	1000	1000	1000	1000	1000	1000	1000	1000	1000	1000	1000

Legend:
 * 30H 043 to 280 unit range (see front cover)
 ** Net nominal cooling capacity = gross cooling capacity minus the water pump heat against the internal evaporator pressure drop
 Nominal Eurovent conditions: evaporator entering/leaving water temperature 12°C and 7°C. Condenser entering/leaving water temperature 30°C and 35°C.
 *** Standardised conditions: evaporator entering/leaving water temperature 12°C and 7°C.
 Condensing temperature dew point 50°C. Fluid temperature = condensing temperature at dew point - refrigerant glide - 5 K subcooling.
 **** The 30H* units have a nitrogen holding charge only.

ELECTRICAL DATA

30H*		043	052	065	091	101	111	121	141	161	195	225	250	280
Power wiring														
Nominal power supply**	V-ph-Hz	400-3-50												
Nominal voltage range	V	360-440												
Auxiliary circuit														
	V-ph-Hz	230-1-50												
Heater power input 30HT	kW	0.25	0.25	0.25	0.38	0.50	0.50	0.50	0.50	0.50	0.63	0.75	0.88	1.00
Heater power input 30HZ	kW	0.36	0.36	0.36	0.54	0.72	0.72	0.72	0.72	0.72	0.90	1.08	1.26	1.44
Nominal unit power input														
	kW													
Standard units 30HT		34.3	43.4	60	62	69	77	82	99	116	145	175	206	233
Condenserless units 30HW		36.9	46.6	62	67	74	83	90	107	129	158	190	222	252
Standard units 30HZ		36.8	46.6	64	66	74	85	88	106	124	155	187	221	249
Condenserless units 30HZ"V"		37.4	47.3	63	68	75	84	92	109	131	160	193	225	255
Nominal unit operating current														
	A													
Standard units 30HT		57	72	100	102	115	127	136	164	192	240	290	342	386
Condenserless units 30HW		61	77	103	111	122	137	149	178	214	262	315	368	417
Standard units 30HZ		61	77	107	109	123	142	146	176	206	258	311	367	414
Condenserless units 30HZ"V"		62	78	105	112	124	139	152	180	217	266	320	374	423
Maximum unit power input***														
	kW													
Standard units 30HT		45	54	75	81	89	98	108	129	151	189	226	264	302
High condensing pressure/condenserless units		51	62	85	93	103	113	124	147	171	214	256	299	342
Standard units 30HZ		42	54	70	75	84	95	102	122	150	180	217	253	286
High condensing pressure/condenserless units		45	58	76	81	92	103	111	133	158	197	237	272	309
Maximum starting current														
	A													
Standard units 30HT/HZ		163	178	247	311	259	340	355	394	496	559	623	687	750
Standard units 30HT/HZ, option "PW"	std	std	std	std	222	202	251	266	305	373	437	501	565	628
High condensing pressure/condenserless units		186	202	280	354	308	388	404	449	563	636	709	782	855
High condensing pressure/condenserless units, option "PW"	std	std	std	std	253	239	287	303	348	425	498	571	644	717
Maximum unit operating current***														
	A													
Standard units 30HT		73	88	127	132	146	161	176	215	254	318	382	445	509
High condensing pressure/condenserless units		85	101	146	151	170	185	201	246	291	364	437	510	582
Standard units 30HZ		70	90	116	124	139	158	169	202	249	299	360	420	475
High condensing pressure/condenserless units		75	96	126	134	153	171	184	221	262	327	393	451	513

Legend:

* 30H 043 to 280 unit range (see front cover)

** 30HZ 250-280units have two power points. For separate power supply, please refer to the table below.

*** At maximum unit operating values.

Size	Max. unit power input, kW				Max. unit current drawn, A				Max. starting current, A			
	30HT Std		30HT"V"+ 30HQ		30HT Std		30HT"V"+ 30HQ		30HT Std		30HT"V"+ 30HQ	
	Circ. A	Circ. B	Circ. A	Circ. B	Circ. A	Circ. B	Circ. A	Circ. B	Circ. A	Circ. B	Circ. A	Circ. B
250	151	113	171	128	254	191	291	218	496	432	564	491
280	151	151	171	171	254	254	291	291	496	496	564	564
Size	30HZ Std		30HZ"V"+ "P"		30HZ Std		30HZ"V"+ "P"		30HZ Std		30HZ"V"+ "P"	
	Circ. A	Circ. B	Circ. A	Circ. B	Circ. A	Circ. B	Circ. A	Circ. B	Circ. A	Circ. B	Circ. A	Circ. B
250	143	110	154	118	237	183	256	196	496	432	564	491
280	143	143	154	154	237	237	256	256	496	496	564	564

Note:

All current values are given at nominal voltage.

Electrical data (cont.)

- 30H* units have a single power connection point (except 30H 250-280 which have two connection points).
- The control box includes the following standard features:
 - Starter and motor protection devices for each compressor
 - Control devices
- Field connections:
 - All connections to the system and the electrical installations must be in full accordance with all applicable local codes.
- The Carrier 30H chillers are designed and built to ensure conformance with these codes. The recommendations of European standard EN 60 204-1 (machine safety - electrical machine components - part 1: general regulations) are specifically taken into account, when designing the electrical equipment.

IMPORTANT:

- Conformance with EN 60 204 is the best means of ensuring compliance with the Machines Directive § 1.5.1. Generally the recommendations of IEC 364 are accepted as compliance with the requirements of the installation directives.
- Annex B of EN 60204-1 describes the electrical characteristics used for the operation of the machines.

- The operating environment for the 30H chillers is specified below:
 - Environment* - Environment as classified in IEC 364 § 3:
 - ambient temperature range: +5°C to +40°C, class AA4*
 - humidity range (non-condensing)*:
 - 50% relative humidity at 40°C
 - 90% relative humidity at 20°C
 - altitude: ≤ 2000 m*
 - indoor installation*
 - presence of water: class AD2 (possibility of water droplets)*
 - presence of hard solids, class AE2 (no significant dust present)
 - presence of corrosive and polluting substances, class AF1 (negligible)
 - vibration and shock, class AG2, AH2
 - Competence of personnel, class BA4* (trained personnel - IEC 364)

- Power supply frequency variation: ≤ 2 Hz.
- The neutral (N) line must not be connected directly to the unit (if necessary use a transformer).
- Overcurrent protection of the power supply conductors is not provided with the unit.
- The factory-installed circuit breaker is of type "a" (EN 60 204-1 § 5.3.2).

NOTE: If particular aspects of an actual installation do not conform to the conditions described above, or if there are other conditions which should be considered, always contact your local Carrier representative.

* The required protection level for this class is IP21B (according to reference document IEC 529). All 30H units are protected to IP23C and fulfill this protection condition.

APPLICATION DATA

Minimum cooler water flow rates

30H*	Min flow rate, l/s
043	4.1
052-065	5.0
091	6.0
101-111	8.5
141-161	9.9
195-280	9.9

* 30H 043 to 280 unit range (see front cover)

Maximum chilled water flow rate

The maximum chilled water flow (>0,09 l/s per kW or <2.8 K temperature difference) is limited by the maximum permitted pressure drop in the evaporator.

Water loop volume

Whatever the size of the system, the water loop minimum volume is given by the following formula:

$$\text{Volume} = \text{CAP (kW)} \times \text{N}^* = \text{litres}$$

where CAP is the nominal system capacity (kW) at the nominal operating conditions of the installation.

Application	N
Air conditioning	3.25
Industrial process cooling	6.50
Low-ambient temperature	6.50

This volume is necessary for stable operation and accurate temperature control.

It is often necessary to add a buffer water reservoir to the circuit in order to achieve the required volume. The reservoir must itself be internally baffled in order to ensure proper mixing of the liquid (water or brine). Refer to the examples below.

NOTE: The compressor must not restart more than 6 times in an hour.

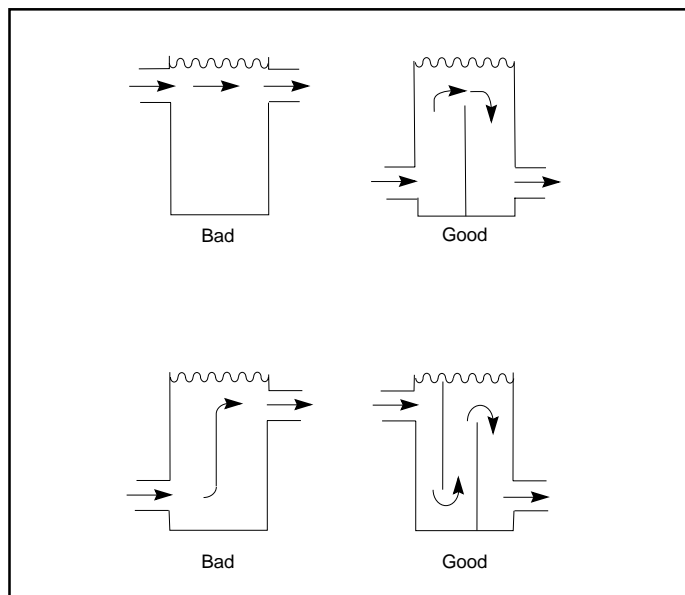

Condenser water flow rates

30H*	Passes	Minimum flow rate, l/s**		Maximum flow rate, l/s***
		Closed loop	Open loop	
043	2	1.00	3.00	12.30
052	2	1.20	3.60	14.40
065	2	1.40	4.20	16.80
091	2	2.47	7.42	29.70
101	2	2.54	7.64	30.60
111	2	3.04	9.13	36.54
121	2	3.54	10.62	42.48
141	2	3.54	10.62	42.48
161	2	3.54	10.62	42.48
195	2	4.00	12.00	48.00
225	2	4.46	13.40	53.64
250	2	5.04	15.14	60.58
280	2	5.62	16.88	67.52

* 30H 018 to 280 unit range (see front cover)

** Based on a water velocity of 0.3 m/s in closed-loop and 0.9 m/s in open-loop systems.

***Based on a water velocity of 3.6 m/s.

Condenser water flow restrictor

CAUTION: To ensure correct operation of the units, this restrictor must be installed. It is supplied with the machine, inside the control box.

30H*	No. of passes	OD, mm	Location
043	2	31	Condenser 09RS 022, circuit B - water outlet
091	2	47	Condenser 09RS 054 - water outlet
111	2	47	Condenser 09RS 054 - water outlet
195	2	47	Condenser 09RS 070 - water outlet
250	2	56	Condenser 09RS 084 - water outlet

INSTALLATION

Safety considerations

Installation, start-up and servicing this equipment can be hazardous due to system pressures, electrical components and equipment location (roofs, elevated structures, etc.).

Only trained, qualified installers and service mechanics should install, start-up and service this equipment.

Untrained personnel can perform basic functions, such as cleaning coils. All other operations should be performed by trained service personnel.

When working on the equipment, observe precautions in the literature, and on tags, stickers, and labels attached to the equipment.

- Follow all safety codes.
- Wear safety glasses and work gloves.
- Use care in handling, rigging and setting down bulky equipment.

WARNING: Before doing any work ensure that the power supply (400 V and 230 V) is disconnected, and switches and isolators are opened and tagged.

During operation some parts of the unit reach or exceed temperatures of 70°C (e.g. compressor discharge side, discharge line). Only trained and qualified engineers, aware of these hot surfaces, are allowed to perform maintenance operations.

Preliminary checks

Check equipment received

- Inspect the unit for damage or missing parts. If damage is detected, or if shipment is incomplete, immediately file a claim with the shipping company.
- Confirm that the unit received is the one ordered. Compare the nameplate data with the order.
- Confirm that all accessories ordered for on-site installation have been delivered, and are complete and undamaged.

Moving and siting the unit

Moving

Do not remove skids, pallets or protective packaging until the unit is in its final position. Move the chiller using tubes or rollers, or lift it, using slings of the correct capacity.

CAUTION: Only use slings at the designated lifting points which are marked on the unit.

Siting

Always refer to the chapter 'Dimensions and clearances' to confirm that there is adequate space for all connections and service operations.

With the chiller in its final location remove the skids, and other devices used to aid in moving it. Level the unit using a spirit level, and bolt the unit to the floor or plinth. Operation of these units may be impaired if they are not level and not securely fixed to their mountings.

We recommend that these chillers be installed either in a basement or at ground level. If one is to be installed above ground level, first check that the permissible floor loading is adequate and that the floor is strong enough and horizontal. If necessary, strengthen and level the floor.

30HT/HZ machines require only the connection of condenser and evaporator water circuits and power and control electrical supplies. 30HW/HZ'V' units differ only in that they require the installation of pipework between the chiller and the remote condensers.

Check compressor mountings

Before the first start-up of the unit proceed as follows:

For 30H* 043-065 units

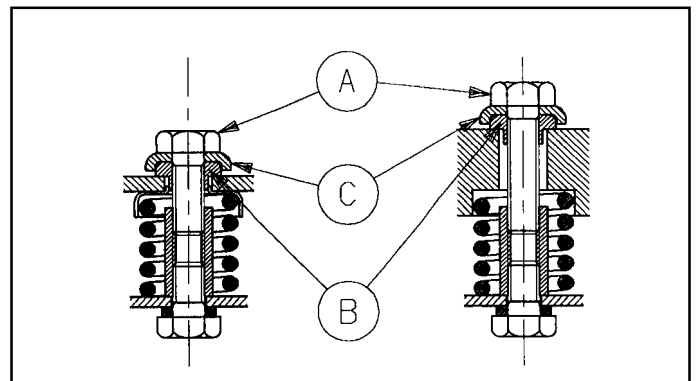

1. Remove the wooden block located under the compressor foot.
2. Remove the screw and washer used for transportation.
3. Assemble screw (A), snubber (B) and plain washer (C).

For 30H* 091-280 units

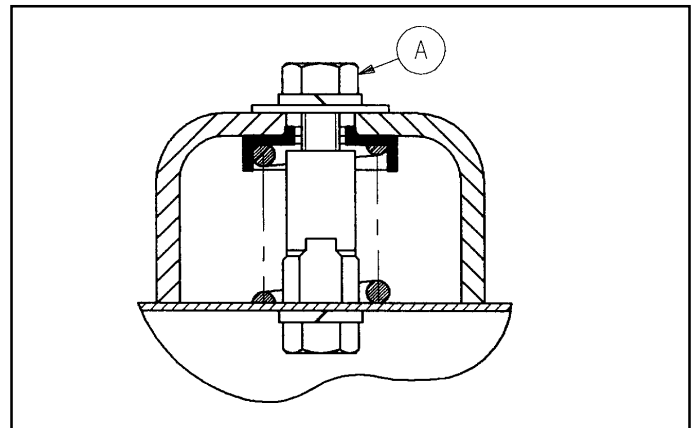

Remove the centre bolt (A) from each spring mounting, so that the compressor support can float freely.

Water connections

Refer to the certified dimensional drawings for the sizes and positions of all water inlet and outlet connections. The water pipes must not transmit any radial or axial force to the heat exchangers or any vibration to the pipework or building.

The water supply must be analysed and appropriate filtering, treatment, control devices, isolation and bleed valves and circuits built in, as necessary. Consult either a water treatment specialist or appropriate literature on the subject.

Operating precautions

The water circuit should be designed to have the least number of elbows and horizontal pipe runs at different levels. Below the basic checks to be done (see also the illustration of a typical hydraulic circuit below).

- Note the water inlets and outlets of the heat exchangers.
- Install manual or automatic air purge valves at all high points in the water circuit.
- Use an expansion chamber or an expansion/relief valve to maintain pressure in the system.
- Install water thermometers in both the entering and leaving water connections close to the evaporator.
- Install drain valves at all low points to allow the whole circuit to be drained. Connect a stop valve in the drain line before operating the chiller.
- Install stop valves, close to the evaporator, in the entering and leaving water lines.
- Use flexible connections to reduce the transmission of vibration to the pipework.
- Insulate all pipework, after testing for leaks, both to reduce thermal leaks and to prevent condensation.
- Cover the insulation with a vapour barrier.

Condenser connections

The condenser is of the multi-tube shell and tube type with removable water boxes to facilitate cleaning of the tubes.

Before making water connections tighten the bolts in both heads to the lower torque shown, following the method described. Tighten in the pairs and sequence indicated according to the size of bolt (see below) using a torque value at the low end of the range given.

Water box tightening sequence

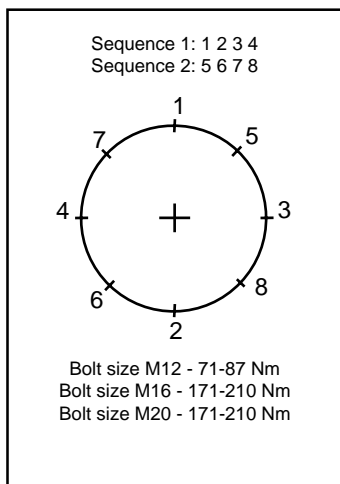

Pipe connections

After welding the pipes to the flanges previously removed from the water boxes:

- Reinstall the pipes and tighten lightly to a torque at the low end of the range.
- Fill the system with water.
- Wait for 10 minutes and check for minor leaks
 - at the water box joints
 - at the flange joints
- Drain the system.
- Disconnect the pipework.
- Tighten the head bolts to their final torque (middle of the range) in the sequence illustrated.
- Reconnect the water pipes, tightening the flange bolts to the mid-range torque value.
- Refill the system with water.
- Pressurize the system.

NOTE: We recommend draining the system and disconnecting the pipework to ensure that the bolts of the heads to which the pipework is connected are correctly and uniformly tightened.

If there is a leak outside the water head:

- Drain the system.
- Disconnect the water pipes.
- In the correct sequence, retighten the head bolts to the maximum torque given for the bolt size.
- Reconnect the pipework, tightening the bolts to their final torque value, i.e. the middle value in the range given for the bolt size.
- Refill the system with water.
- Pressurize the system.

Freeze protection

Cooler and water-cooled condenser protection

If the chiller or the water piping is in an area where the ambient temperature can fall below 0°C it is recommended to add an antifreeze solution to protect the unit and the water piping to a temperatures of 8 K below the lowest anticipated temperature.

Use only antifreeze solutions, approved for heat exchanger duty. If the system is not protected by an antifreeze solution and will not be used during the freezing weather conditions, draining of the cooler and outdoor piping is recommended.

Typical hydraulic circuit diagram

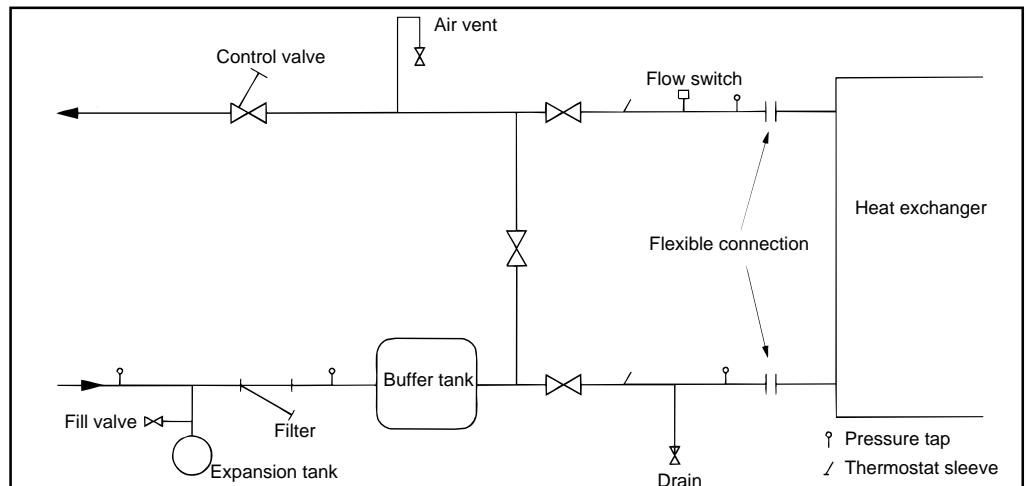

INSTALLATION OF UNITS WITH REMOTE CONDENSERS

To ensure optimum and reliable operation of condenserless units (split units for connection to remote condensers) the points listed below must be followed, before connection of these machines to the remote condensers:

1. Install the valves supplied with the machines on the discharge line (see unit description table below).
2. Size the discharge piping in accordance with the recommendations of the Carrier System Design Manual (if necessary install a double riser to ensure correct oil circulation in the refrigerant circuit).
3. Depending on the actual installation and the routing of the discharge lines it may be necessary to include an additional muffler (to reduce pulsations and noise emission) between the liquid chiller and the condenser. For component selection contact our customer support team.
4. Select a condenser with integrated subcooler to obtain an actual subcooling of at least 3 K at the expansion device inlet (careful when determining subcooling with R-407C).
5. Maintain a condensing pressure which is as stable as possible (pressure switch staging and/or accessory PRO-DIALOG card). For low-temperature and part-load operation a speed transformer may be required on the first fan stage.
6. If the system can have several operating modes (summer/winter, dual set point, heat reclaim...), it is necessary to include a receiver to absorb charge variations.
7. For units not equipped with a liquid line solenoid valve (see unit description table below) this type of valve must be installed between the liquid chiller and the condenser (closed if no flow is present). This prevents refrigerant charge migration to the evaporator which could damage the compressors at the restart.

Power supply

The power supply must conform to the specification on the chiller nameplate. The supply voltage must be within the range specified in the electrical data table.

For connections refer to the wiring diagrams.

WARNING: Operation of the chiller with an improper supply voltage or with excessive phase imbalance constitutes abuse which will invalidate the Carrier warranty. If the phase imbalance exceeds 2% for voltage, or 1% for current, contact your local electricity supply company at once and ensure that the chiller is not switched on until corrective measures have been taken.

Voltage phase imbalance (%) :

$$= \frac{100 \times \text{max. deviation from average voltage deviation}}{\text{Average voltage}}$$

Electrical checks

WARNING: Never switch off the power supply to the crankcase heaters unless the chiller is out of service for a seasonal shutdown or lengthy repair. The heaters must be re-energised for at least 24 hours before the chiller is restarted.

- a. Switch the unit off.
- b. Open the control circuit disconnect switch.
- c. Check the transformer connections.
- d. Ensure that the control circuit corresponds to the wiring diagram for the unit.
- e. Check that all electrical connections are secure at the terminals, contactors, bus bars and compressor terminal blocks.

Start-up

Preliminary checks

Never be tempted to start the chiller without reading fully, and understanding, the operating instructions and without having carried out the following pre-start checks :

Confirm that all crankcase heaters are working by feeling all compressor crankcases. Every compressor has a 200 W cartridge heater (see the wiring diagram). The heater remains energised even when the chiller is shut down to stop the lubricating oil from absorbing refrigerant.

Check the operation of all accessories - chilled water circulating pumps, air handlers and other equipment connected to the evaporator. Follow the individual manufacturer's instructions for this equipment.

It is recommended to connect the auxiliary contact of the water pump contactor to ensure maximum unit safety (see wiring diagram delivered with the unit).

Unit range	Valve	Expansion device		Liquid line solenoid valve	
		Supplied	Option Standard	With thermostatic expansion valve	With electronic expansion valve
30HZ"V"/30HW 043-065	Factory-installed in discharge line	Thermostatic	Electronic	Factory-installed	No solenoid valve
30HZ"V"/30HW 091-280	Supplied with machine, not installed	Electronic			No solenoid valve

2 valves per circuit for sizes 250-280

Fill the chilled water circuit with clean water, and an inhibitor formulated specifically for this purpose, or fill it with another non-corrosive fluid to be chilled.

Purge air at all high points in the system. If water temperatures below 5°C are likely, add the appropriate volume of ethylene glycol to prevent freezing.

Confirm that the suction and discharge line stop valves are fully opened.

Open the refrigerant line valves. Check again that the water circuit valves are open.

Check that oil is visible in each compressor sight glass to between 1/8 and 3/8 of the total glass depth (check for all compressors).

Confirm that there are no refrigerant leaks.

Confirm that all crankcase heaters are firmly in place, and check the secure positioning of all control sensors.

Confirm that discharge muffler securing bands and discharge line connections are tight.

Check that all electrical connections are secure.

Actual start-up

IMPORTANT:

- Commissioning and start-up of the chiller must be supervised by a qualified refrigeration engineer.
 - Start-up and operating tests must be carried out with a thermal load applied and water circulating in the evaporator.
 - All set point adjustments and control tests must be carried out before the unit is started up.
 - PLEASE REFER TO THE CONTROLS MANUAL FOR THE UNIT.
- a. Start up the unit.
 - b. Check that all safety devices are satisfied, particularly the high pressure switches.

For this purpose:

- Stop the condenser water circulation pumps.
- Operate the machine until the high pressure switch trips and verify that the pressure does not exceed the cut-out value.
- Using the control point as a reference, verify the correct operation of the unit.

High pressure switch control

Unit	Set point (bar)
30HT	19
30HZ	22
30HW/HT"W"	25
30HQ/HZ"W"/HZ"P"	25
30HZ"V"	29

SERVICING REFRIGERATION COMPONENTS

Any technician attending the machine for any purpose must be a fully qualified refrigeration engineer.

WARNING: Before doing any work on the machine ensure that the power is switched and locked off and that all isolators are tagged. If a refrigerant circuit is opened, it must be evacuated, and recharged, after ensuring that the refrigerant is clean and free from impurities, the filter-drier has been changed and the unit has been tested for leaks. Before any operation on a refrigerant circuit, it is necessary to remove the complete charge of refrigerant from the unit with a refrigerant charge recovery group.

General maintenance

Keep the unit itself and the space around it clean and free of obstructions. Remove all rubbish such as packing materials, as soon as the installation is completed.

Regularly clean the exposed pipework to remove all dust and dirt. This makes detection of water leaks easier, and they can be repaired before more serious faults develop.

Confirm that all screwed and bolted connections and joints are secure. Secure connections prevent leaks and vibration from developing.

Check that all insulation joints are securely closed and that all insulation is firmly in place. Check all heat exchangers and all pipework.

Confirm regularly that any phase imbalance in the three-phase power supply is within acceptable limits.

Lubricate the hinges, locks and latches on the electrical control box doors sparingly.

Liquid refrigerant charging

Checking the charge

WARNING: When adjusting the refrigerant charge always ensure that water is circulating in the condenser and evaporator to prevent any possibility of freezing up. Damage caused by freezing is not covered by the product warranty.

30HT/30HZ units are shipped with a full normal charge of refrigerant. Refer to the Physical Data table. If it is nevertheless necessary to add more refrigerant, run the unit at full capacity for some time and then add refrigerant until there are no bubbles in the sight glass. This will generally mean adding more refrigerant than would be needed to prevent bubbles from being seen in the sight glass.

30HW/30HZV condenserless units are shipped with only a nitrogen charge, leaving the whole system to be charged after the installation is complete. To adjust the charge continue adding liquid refrigerant, with the unit running at full capacity until there are no bubbles visible in the sight glass.

WARNING: To ensure proper operation of 30HW/30HZ"V" units there must be at least 3 K of subcooling as the liquid refrigerant enters the expansion valve.

The units 30H* 043-280 use refrigerant. For your information, we are reproducing here some extracts from the official publication dealing with the design, installation, operation and maintenance of air conditioning and refrigeration systems and the training of people involved in these activities, agreed by the air conditioning and refrigeration industry.

Refrigerant guidelines

Refrigeration installations must be inspected and maintained regularly and rigorously by specialists. Their activities must be overseen and checked by properly trained people.

To minimise discharge to the atmosphere, refrigerants and lubricating oil must be transferred using methods which reduce leaks and losses to a minimum.

- Leaks must be repaired immediately
- A valve on the condenser liquid refrigerant outlet line enables the refrigerant charge to be transferred to the receiver provided specifically for this purpose.
- If the residual pressure is too low to make the transfer alone, a purpose-built refrigerant recovery unit must be used.
- Compressor lubricating oil contains refrigerant. Any oil drained from a system during maintenance must therefore be handled and stored accordingly.
- Refrigerant under pressure must never be discharged to the atmosphere.

Recharging liquid refrigerant

CAUTION: 30HZ 043-280 units are charged with liquid HFC-407C refrigerant.

This non-azeotropic refrigerant blend consists of 23% R-32, 25% of R-125 and 52% R-134a, and is characterised by the fact that at the time of the change in state the temperature of the liquid/vapour mixture is not constant, as with azeotropic refrigerants. All checks must be pressure tests, and the appropriate pressure/temperature ratio table must be used for the interpretation of the values.

Leak detection is especially important for units charged with refrigerant R-407C. Depending on whether the leak occurs in the liquid or in the vapour phase, the proportion of the different components in the remaining liquid is not the same.

NOTE: Regularly carry out leak checks and immediately repair any leak found.

Undercharge

If there is not enough refrigerant in the system, this is indicated by gas bubbles in the moisture sight glass. There are two possibilities:

- Small undercharge (bubbles in the sight glass, no significant change in suction pressure).
 - After detection and repair the unit can be recharged.
 - The replenishment of the charge must always be done in the liquid phase at the liquid line. The refrigerant cylinder must contain a minimum of 10% of its initial charge.

- Significant undercharge (large bubbles in the sight glass, drop in suction pressure).
 - Small units (charge below 20 kg per circuit). After detection and repair completely drain the refrigerant charge, using a refrigerant recovery unit, then recharge completely, following the precautions given above.
 - Large units (charge above 20 kg per circuit). After detection and repair completely recharge the unit as described above, operate it for a few minutes and then let a specialist carry out a chromatographic analysis to verify the composition of the blend (range: R-32: 22-24%, R-125: 23-27%, R-134a: 50-54%).

Compressors

Checking the oil charge

Check the oil level and add or remove oil as necessary so that the level is 1/8 to 3/8 up each sight glass with the compressors running normally.

WARNING: Use only oils which have been approved for use in refrigeration compressors. Never use oil which has been exposed to air. Oils for R-22 compressors are NOT compatible with R-407C.

Recommended oil:

30H* R-22 units:

- Mineral oil, Carrier specification No. PP 33-2
- Suniso 3 GS (Sun Oil Co)
- Capella WF 32-150
- Clavus G 32 (Shell Oil Co)
- Gargoyle Artic (Mobil Oil) - original charge

30HZ R-407C units:

- Mineral oil, Carrier specification No. PP 47-26
- Polyolester Mobil Oil EAL 68

WARNING: All fixing devices and fittings which may have been removed during servicing must always be replaced upon completion of the work and before restarting the unit.

Tightening torques to be applied

Description	Diameter, mm	Torque, Nm
Discharge valve	M16	135-140
Cylinder head	M12	75-87
Suction and liquid line flange	M12	75-87
Suction valve	M16	135-140

Compressor motor protection

Circuit breaker

Calibrated, thermo-magnetic, manually reset circuit breakers protect the compressors against locked rotors and excessive current draw.

WARNING: Never bypass a circuit breaker or increase its setting. If a circuit breaker trips, find out why it has done so and correct the problem before resetting the breaker.

Discharge gas thermostat (DGT)

(only for units with low temperature option)

A sensor in each compressor discharge line opens to shut down the compressor if the discharge gas temperature exceeds the preset level.

Cut out 146°C Cut in 113°C

Crankcase heater

Each compressor is fitted with an electric resistance crankcase heater which prevents any absorption of refrigerant by the compressor lubricating oil when the compressor is shut down. Each heater is held in place by a screw clip which must be secure. Prolonged exposure of the heater to air will result in its destruction. The heater is energized when the compressor is switched off.

WARNING: Never open or disconnect any switch or circuit breaker which will cut the supply to the heaters, unless the unit is to be shut down for lengthy service or repair or for a seasonal shut down. In all cases the heater must be energised for at least 24 hours before a compressor is restarted.

Compressor protection circuit board (STARTERGUARD)

The purpose of this card is to monitor the compressor operating environment, in particular:

- the crankcase heaters
- the contactors
- the part winding start timer
- the control wiring between these components

Heat exchangers

Evaporator

Protection devices

Freeze-up prevention thermostat

The evaporator is protected against loss of water and freeze-up. The protection is provided by two sensors installed in the evaporator: one on the entering water side and the other on the leaving water outlet pipe.

Evaporator maintenance

The evaporator can be removed using the following procedure:

- Close the chilled water supply and return valves (if installed), and disconnect the chilled water supply and return pipe connections.
- Drain the water from the cooler.
- Remove all temperature sensors from the cooler.
- Fold back the insulation at the refrigerant line connections.

When the evaporator heads and manifolds are removed, the outer tube end plates will be visible.

Six evaporator tubes are swaged into the end plate and cannot be removed. A dot punch mark in the end plate opposite each one identifies each of them. If any of them develop a leak, the tube must be plugged, as described below.

Plugging evaporator tubes

A leaking tube can be plugged pending replacement. The number of tubes plugged will determine when they should be replaced. Check with Carrier the effect upon chiller performance of plugging a number of tubes. Carrier will need to know the number of tubes to be plugged and their positions. The figure below shows the Elliott method of plugging tubes.

WARNING: Take care when inserting plugs not to damage the plate material between the tubes. Avoid excessive force. Clean all components with Locquic N and then coat all surfaces with several drops of Loctite 75 to ensure a good seal without applying excessive force.

Elliott tube plug

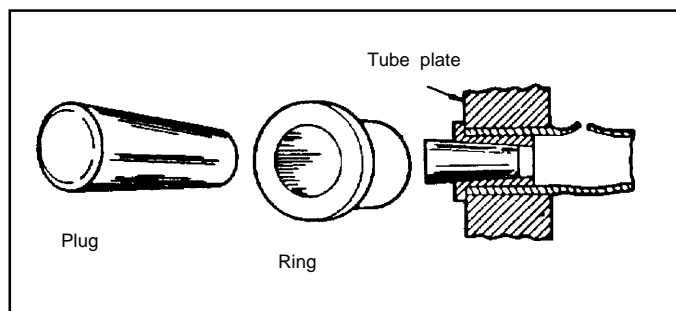

Components	Part number
Tube brass plug	---T-853--103500S-*
Tube brass ring	---T-853--002570S-*
Brass plug (holes without tubes)	---T-853--1031--S-*
Brass ring (holes without tubes)	---T-853--002631S-*
Loctite	No. 75*
Locquic	"N"*

* Order directly from your Carrier distributor

Replacing cooler tubes

Retubing must be done only by a properly trained service engineer. Most standard practices can be applied, but for cooler tubes a 5% crush allowance is made for tube expansion and twisting (15.87 mm diameter tubes are used in these coolers).

The table below gives the specification of the materials used.

Example:

Tube sheet hole diameter	16.00 mm
Tube outside diameter	15.87 mm
Clearance	0.13 mm
Tube inside diameter before rolling	14.27 mm
Tube inside diameter after rolling	14.48 mm

NOTE: Tubes next to the gasket webs must be flush with the tube sheets at either end of the cooler.

Preparation of gaskets

When rebuilding the cooler, new gaskets must always be used. They must conform to the Carrier specification for compressed gaskets.

- Clean the gasket and its place on the tube sheet.
- Cover the two matching surfaces (gasket and tube sheet) with adhesive, and stick them together.
- Let the joint dry for 5 minutes.
- Moisten the joint with a small amount of compressor oil.
- Reinstall the evaporator head within 30 minutes.

Tightening cooler head bolts

Cooler head bolts must be tightened in the specified sequence and to the correct torque.

Use this tightening sequence:

- Hand tighten the four bolts as shown below in stage 1.
- Hand tighten the next four bolts as shown below in stage 2.
- Starting at the 12 o'clock position, and working clockwise, insert and hand tighten the remaining outer bolts.
- Insert and tighten the six screws in the center of the head.

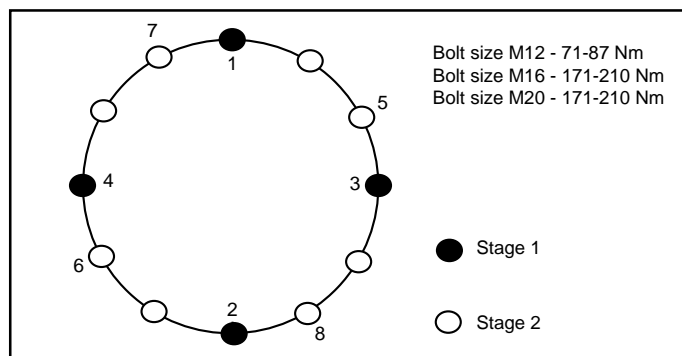

- Starting again at 12 o'clock and working clockwise tighten the outer bolts to the correct torque.
- Not less than one hour later insert and tighten the six bolts in the centre of the head, using the torque values given.
- After the cooler has been refilled with clean refrigerant, use a soap and water solution or an electronic detector to confirm that there are no leaks.
- Replace the evaporator insulation and temperature sensors.

Condensers

Precautions for low temperature duty

When 30H* units are likely to experience return chilled water or brine temperatures of or below 0°C, the condenser water circulating pumps must continue to run after the last compressor has shut down.

Refrigerant circuit

Thermal expansion valve (TXV)

The function of the thermal expansion valve is to control the flow of liquid refrigerant. The valve is controlled by a sensor bulb in the compressor suction line. It is factory set to maintain refrigerant superheat of 4 K, based on the dew point. This setting should not be changed unless absolutely necessary.

Filter-drier

The filter-drier keeps the circuit clean and free of moisture. The sight glass indicates when it is necessary to change the cartridge in the filter-drier. A temperature difference between the inlet and the outlet of the filter-drier indicates fouling of the drier.

NOTE: The unit must run for at least 12 hours before it can give an accurate indication, because only with the unit running is the indicator in continuous contact with the refrigerant.

Liquid line service valve

This valve provides, in each circuit, a liquid refrigerant charging port and, in conjunction with the compressor discharge line valves, enables liquid refrigerant to be pumped to the high pressure side of the system.

TROUBLESHOOTING CHART

Below we list a series of possible faults, along with the probable causes and suggested solutions. In the event of a unit malfunction, it is advisable to disconnect the power supply and ascertain the cause.

SYMPTOMS	CAUSE	REMEDY
Unit does not start	Lack of power supply	Connect power supply
	Main switch open	Close switch
	Low line voltage	Check voltage and remedy the deficiency
	A protection device has tripped	Reset
	Contactors stuck open	Replace contactor
	Seized compressor or short circuit	Check windings (grounded or short circuit), replace compressor
	Loose electrical connections	Check connections
Unit operates continually or starts and stops frequently	Defective compressor contactor	Replace contactor
	Defective compressor	Check valves, replace compressor
	Refrigerant losses	Check and add the necessary charge
Compressor continually cuts out at low pressure	Refrigerant losses	Add the necessary refrigerant charge
	Low water flow in the evaporator	Check water pump
	Blocked expansion valve	Clean or replace
	Blocked filter-drier	Replace filter
Compressor continually cuts out at high pressure	Defective high pressure switch	Replace pressure switch
	Low water flow in the condenser	Check water pump
	Blocked condenser	Clean condenser
Noises in the system	Piping vibrations	Support piping, check supports and tightness
	Noisy compressor	Check valve plate, change if necessary
	Badly fitting panels	Install correctly
Compressor loses oil	Leak in the system	Repair leak
Water losses	Defective inlet or outlet connections	Check and tighten if necessary

