



## Oil separators

### → TURBOIL-R®

#### ■ Applications

- Separation and recovery of the oil carried by the refrigerant in vapour phase at compressor outlet of refrigerating and air conditioning installations.
- The TURBOIL-R® oil separators receiver limit the amount of oil within the circuit, thus allowing increasing the performances of the heat exchangers and prevent abnormal wear, even the breakage of compressors by lack of oil.
- They must be used in applications where the return of oil through the suction is not guaranteed: facilities with long pipes, oil traps, with evaporation temperatures lower than - 5 °C, with compressors in parallel, or with variable speed, for systems with multiple compressor stages in cascade, Flood, Booster...
- They ensure a regulated oil return to the compressor crankcases and participate by their position on the circuit, in the reduction of the vibrations generated by the compressors and sound level of the discharge gas.
- The choice of the oil separators receivers TURBOIL-R® avoids the assembly of a separate oil receiver.

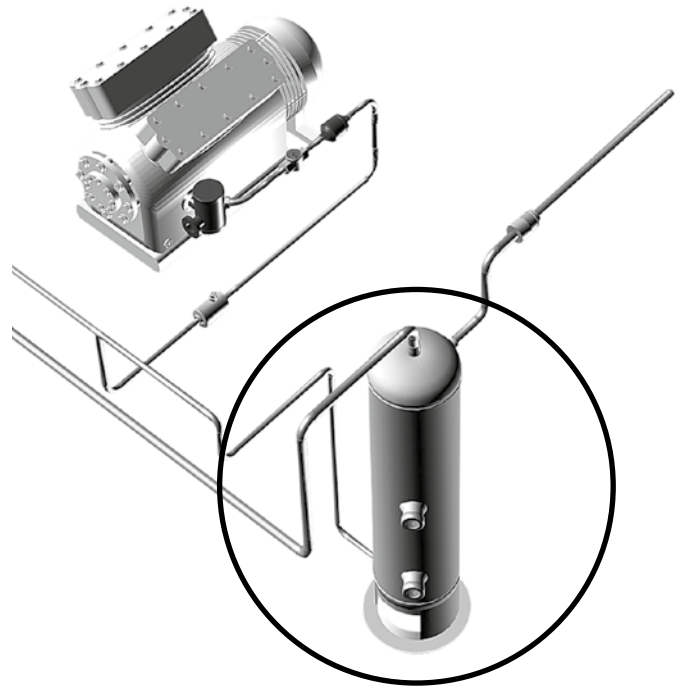

#### ■ Functional features

- Products are compatible with CFCs, HCFCs, HFCs, CO<sub>2</sub>, as well as with their associated oils and additives. Products are designed for use of non-hazardous refrigerants from group 2 of PED 2014/68/EU. To use CARLY components with fluids of the hydrocarbon group 1 – Propane R290, Butane R600, Isobutane R600a, Propylene R1270 – with HFOs and transcritical CO<sub>2</sub> and for a RANKINE organic cycle application, contact CARLY technical department.
- Product classification in CE categories is done with the PED 2014/68/EU table, corresponding to a volume-based selection.
- Hermetically sealed outer steel enclosure with paint to ensure a high resistance to corrosion.
- The oil receiver function is ensured by a built-in receiver
- High pressure oil outlet by a 3/8" SAE Rotalock stop valve
- The TURBOIL-R® do not have any internal oil regulation system (float, valve and needle)
- Models with a 4 litres oil reserve and more, have built-in fastening means



#### Customization possible on demand:

- Separator with oil return by capillary (onboard refrigeration)
- Centrifugal separator
- Receiver volume, connections, etc...

#### ■ CARLY advantages

- Maximum working pressure: 46 bar.
- Very important simplification and cost reduction compared with a traditional oil system:
  - drastic reduction of piping lengths and number of components
  - important reduction of mounting time
  - limitation of machine footprint
  - suppression of the differential valve joining the oil receiver and the suction line
  - limitation of the risk of leak thanks to the simplification of the oil return system.
- Fitted with the efficient TURBOIL® oil separation system.
- Low pressure drop compare to a separator using coalescent cores.
- Do not need specific maintenance operations, because there is no cores to be replace periodically.
- Presence of two sight glasses with colour balls on the receiver part, for a better reading of the oil level.
- Very large range.



# Oil separators

## → TURBOIL-R®

### ■ Warning

Before selecting or installing any component, please refer to the chapter 0 - **WARNING**.

### ■ General assembly precautions

The installation of a component in a refrigeration system by a skilled professional, requires some precautions:

- Some are specific to each component, and in this case, they are specified in the

**RECOMMENDATIONS SPECIFIC** part defined hereafter ;

- Other are general to all CARLY components, they are presented in the chapter 115 – **GENERAL ASSEMBLY PRECAUTIONS**.

- The recommendations relating to the CARLY components for the subcritical CO<sub>2</sub> applications are also developed in chapter 115 – **GENERAL ASSEMBLY PRECAUTIONS**.

### ■ Recommendations specific to the oil separators receivers TURBOIL-R

- The recommendations are identical to those given for the TURBOIL® oil separators (refer to chapter 41)
- Given the high pressure at the oil outlet of the TURBOIL-R®, the use of mechanical oil regulator LEVOIL is not possible; it is therefore recommended to use an electronic oil regulator.
- In the case of multi-compressors installation, CARLY recommends the use of one TURBOIL-R® by compressor.
- Connection diameter of the oil separators should be higher than or equal to the diameter of the discharge line.
- Upon commissioning of a new installation, fill the TURBOIL-R® receiver part with oil identical to the one used in the compressors, up to half the upper sight glass, corresponding to the volume of oil V2 in the Technical features table (refer to next pages).
- During the first two days of operation of the installation, carefully monitor the oil level in the separator receiver and keep it at half the higher sight glass; then, no extra oil shall be added, as long as the level does not go below half the lower sight glass.
- In the case of an installation that is already operating, the oil should be added very carefully. Reintegration of the oil distributed until then in the installation must, after the first day of operation, be sufficient to fill the TURBOIL-R® receiver part and reach the upper sight glass. If the oil level has not reached the upper sight glass, then the necessary quantity of oil should be added. But, if the oil level is higher than the upper sight glass, it is imperative to empty the surplus; this operation is possible via the oil separator receiver's lower valve.

- Systematically use the same oil as that of the compressor.
- The efficiency of the oil separation is never 100 %, especially with variable operating regimes. The implementation of an oil separator does not exempt to avoid any trap oil and slopes in the direction of the fluid during the design and the construction of the pipes of the unit.
- A check valve can be installed on the pipe at the gas outlet of the oil separator,

in order to avoid any return of liquid refrigerant from the condenser.

- The O-ring gasket should be replaced after each removal of the sight glass; screw it back complying with the recommended 25 N.m tightening torque.
- The PTFE gasket of the Rotalock valve must be replaced after each disassembly; the recommended tightening torque is 25 N.m.

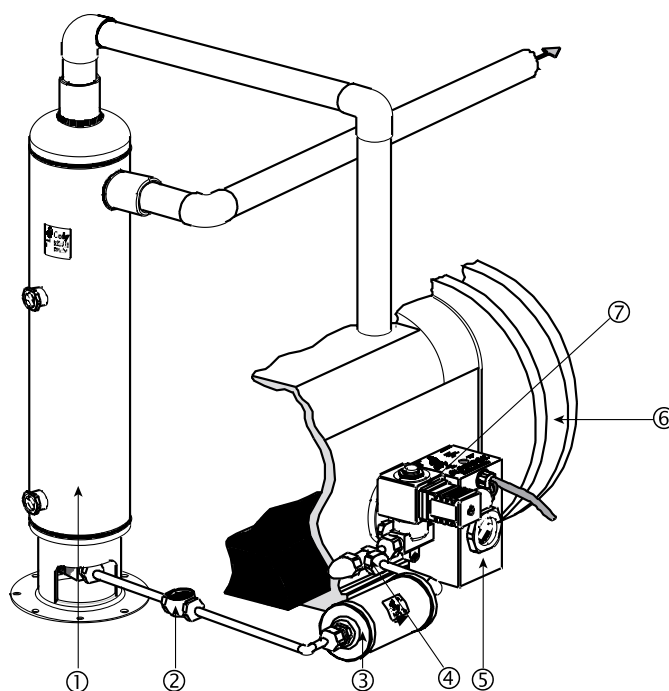

- ① TURBOIL-R® oil separator receiver
- ② HCYP oil sight glass
- ③ HYDROIL filter drier for POE oil
- ④ HCYVI shut-off valve

- ⑤ Electronic oil level regulator
- ⑥ Compressor
- ⑦ Solenoid valve



# Oil separators

## → TURBOIL-R®

### ■ Example of selection

An oil separator receiver is selected in two stages: a first stage sets the size of the oil separator and its connections, and a second stage determines the volume of the oil receiver part, all based on the installation's operation parameters (refrigerating capacity, evaporation and condensation temperatures, type of refrigerant, number and type of compressors ...).

#### 1 - Selection by capacity

The sizing of a product implies for the buyer to take into account the conditions under which the product will operate (temperature, pressure, refrigerant, oil, external environment). The values of the selection tables proposed in the CARLY catalogue match accurate test conditions.

We recommend that you convert your operating data into data matching the CARLY selection table so that you can perform a rigorous and correct sizing.

**For a condensation temperature different from 38°C, it is recommended to convert the installation's refrigerating capacity using the following formula:**

$$Q_{O}^{TK\ 38} = Q_{O}^{TK\ x} / \{ (TKx - 38) \times 0,0143 + 1 \}$$

- <sup>(1)</sup>  $Q_{O}^{TK\ x}$  = installation refrigerating capacity at initial condensing temperature (kW)
- $TK\ x$  = initial condensing temperature (°C)
- $Q_{O}^{TK\ 38}$  = installation refrigerating capacity at condensing temperature 38 °C (kW)

#### SELECTION OF A TURBOIL-R® MODEL CORRESPONDING TO THE CORRECTED REFRIGERATING CAPACITY

• Installation operating with R404A under the following conditions:

- $T_o = -10\ ^\circ\text{C}$
- $TK = 30\ ^\circ\text{C}$
- $Q_{O}^{TK\ x} = 75\ \text{kW}$
- Compressor discharge = 1" 5/8

• Which TURBOIL® to choose?

Application of the formula:

$$Q_{O}^{TK\ 38} = Q_{O}^{TK\ x} / \{ (TKx - 38) \times 0,0143 + 1 \}$$

$$75 / \{ (30 - 38) \times 0,0143 + 1 \} = 85\ \text{kW}$$

Refer to the selection table next page

**Result:**

**TURBOIL-R® 48013 S or 78013 S or 128013 S,**

o select according to the chosen volume of the oil reserve (4, 7 or 12 litres).

**Choice of the volume of the oil reserve: see chapter hereafter.**

*Make sure that the TURBOIL-R® oil separator connection diameter is at least equal to the compressor discharge line diameter. The selected oil separator has a connection diameter identical to the piping diameter.*

<sup>(1)</sup> Chapter «Abbreviations and units» (refer to chapter 113).



# Oil separators

## → TURBOIL-R®

### ■ Exemple de sélection donné à titre indicatif

#### 2 - Selection of the necessary volume of the oil receiver

The volume of the oil receiver depends on the number of compressors, their oil load, the application and the operating conditions.

**Example: for a single stage installation with 3 compressors mounted in parallel, which have the following theoretical swept volumes (Vmb):**

- Vmb1 = 24 m<sup>3</sup>/h
- Vmb2 = 24 m<sup>3</sup>/h
- Vmb3 = 18 m<sup>3</sup>/h

Number of compressors : Nc = 3

Average swept volume :  $(24 + 24 + 18) / 3 = 22 \text{ m}^3/\text{h}$

Refer to the selection table above, which gives an oil receiver volume of 7,7-7,8 litres

#### Result:

**TURBOIL-R 78013 S for 85 kW, with a volume of oil receiver of 7,7 litres**

Volume of the oil reserve							
2,3 - 2,5 L		4,3 L		7,7 - 7,8 L		11,7 - 12,7 L	
Nc <sup>(1)</sup>	Vmb <sup>(2)</sup>	Nc	Vmb	Nc	Vmb	Nc	Vmb
1	0 - 40	1	4 - 60	1	60 - 120	1	120 - 280
2	0 - 20	2	4 - 30	2	30 - 60	2	60 - 140
3	0 - 14	3	4 - 20	3	20 - 40	3	40 - 95
				4	15 - 30	4	30 - 70
						5	25 - 55
						6	20 - 45

<sup>(1)</sup> Nc : Number of compressors

<sup>(2)</sup> Vmb : Average swept volume per each compressor;  $Vmb = (Vmb_1 + Vmb_2 + \dots + Vmb_N) / Nc \text{ en m}^3/\text{h}$

In the case of bi-stage systems, for the selection of the oil receiver, only take into account the swept volume of the first stage compressors. In the case of an application with long pipes or with several machines, do not hesitate to over-size the receiver and, if any doubt, contact the CARLY technical service.



## Oil separators

### ➔ TURBOIL-R®

#### ■ Selection table

CARLY references	Connections To solder ODF  inch	CARLY references	Connections To solder ODF  mm	Refrigerating capacity kW <sup>(1)</sup>												
				R22			R134a			R404A R507			R407C R410A			R744 <sup>(2)</sup>
				-40 °C	-10 °C	+5 °C	-40 °C	-10 °C	+5 °C	-40 °C	-10 °C	+5 °C	-40 °C	-10 °C	+5 °C	-40 °C
TURBOIL-R 22505 S/MMS	5/8	TURBOIL-R 22505 S/MMS	16	17	22	24	12	15	17	17	22	25	16	21	24	27
TURBOIL-R 23007 S/MMS	7/8	TURBOIL-R 23007 S/MMS	22	24	27	30	18	23	25	26	30	32	25	29	31	54
TURBOIL-R 23009 S	1 1/8	TURBOIL-R 23009 MMS	28	28	32	36	19	25	28	29	36	40	28	34	38	95
TURBOIL-R 23011 S/MMS	1 3/8	TURBOIL-R 23011 S/MMS	35	32	40	45	21	27	31	32	40	47	31	38	45	124
TURBOIL-R 47009 S	1 1/8	TURBOIL-R 47009 MMS	28	42	50	55	34	37	42	42	54	60	41	48	54	95
TURBOIL-R 47011 S/MMS	1 3/8	TURBOIL-R 47011 S/MMS	35	48	55	60	38	46	50	48	60	70	46	57	67	149
TURBOIL-R 48013 S	1 5/8	TURBOIL-R 48013 MMS	42	65	80	90	45	60	70	65	85	94	62	81	90	210
TURBOIL-R 49017 S/MMS	2 1/8	TURBOIL-R 49017 S/MMS	54	85	100	110	58	70	80	87	105	120	83	100	114	288
TURBOIL-R 77011 S/MMS	1 3/8	TURBOIL-R 77011 S/MMS	35	48	55	60	38	46	50	48	60	70	46	57	67	149
TURBOIL-R 78013 S	1 5/8	TURBOIL-R 78013 MMS	42	65	80	90	45	60	70	65	85	94	62	81	90	210
TURBOIL-R 79017 S/MMS	2 1/8	TURBOIL-R 79017 S/MMS	54	85	100	110	58	70	80	87	105	120	83	100	114	288
TURBOIL-R 127011 S/MMS	1 3/8	TURBOIL-R 127011 S/MMS	35	48	55	60	38	46	50	48	60	70	46	57	67	149
TURBOIL-R 128013 S	1 5/8	TURBOIL-R 128013 MMS	42	65	80	90	45	60	70	65	85	94	62	81	90	210
TURBOIL-R 129017 S/MMS	2 1/8	TURBOIL-R 129017 S/MMS	54	85	100	110	58	70	80	87	105	120	83	100	114	288
TURBOIL-R 815017 S/MMS	2 1/8	TURBOIL-R 815017 S/MMS	54	121	149	170	91	112	127	125	154	175	119	147	167	367
TURBOIL-R 815021 S	2 5/8	TURBOIL-R 815021 MMS	67	138	170	194	104	128	146	142	175	200	135	167	190	565
TURBOIL-R 830025 S	3 1/8	TURBOIL-R 830025 MMS	80	303	372	424	228	280	318	310	380	430	295	362	410	643
TURBOIL-R 1217 S/MMS	2 1/8	TURBOIL-R 1217 S/MMS	54	121	149	170	91	112	127	125	154	175	119	147	167	367
TURBOIL-R 1221 S	2 5/8	TURBOIL-R 1221 MMS	67	138	170	194	104	128	146	142	175	200	135	167	190	565
TURBOIL-R 1225 S	3 1/8	TURBOIL-R 1225 MMS	80	303	372	424	228	280	318	310	380	430	295	362	410	643

<sup>(1)</sup> The indicated refrigerating capacities take into account a condensation temperature of + 38 °C, a 5 °C subcooling, and an aspirated gas temperature of + 18 °C.

<sup>(2)</sup> The indicated refrigerating capacities take into account a condensation temperature  $T_k$  of 0 °C, an evaporating temperature  $T_0$  of - 40 °C, a liquid subcooling of 2K and a suction gaz temperature of - 30 °C.

Refer to selection example page 42.3.



# Oil separators

## → TURBOIL-R®

### ■ Technical features

CARLY references	Connections types <sup>(1)</sup>	Drawing No	Dimensions mm								
			Ø1	Ø2	L	E1	E2	E3	E4	E5	
TURBOIL-R 22505 S/MMS	2	1	101,6	109	548	82	73	538	207	117	
TURBOIL-R 23007 S/MMS	2	1	101,6	109	558	97	83	548	207	117	
TURBOIL-R 23009 S	TURBOIL-R 23009 MMS	3	1	101,6	109	623	107	80	613	207	117
TURBOIL-R 23011 S/MMS		3	1	101,6	109	632	116	90	622	207	117
TURBOIL-R 47009 S	TURBOIL-R 47009 MMS	3	2	152,4	156	566	141	113	526	150	180
TURBOIL-R 47011 S/MMS		3	2	152,4	156	576	151	114	536	150	180
TURBOIL-R 48013 S	TURBOIL-R 48013 MMS	3	2	152,4	156	655	151	114	615	150	180
TURBOIL-R 49017 S/MMS		3	2	152,4	156	669	164	128	629	150	180
TURBOIL-R 77011 S/MMS		3	2	152,4	156	775	151	114	735	345	180
TURBOIL-R 78013 S	TURBOIL-R 78013 MMS	3	2	152,4	156	851	151	114	811	345	180
TURBOIL-R 79017 S/MMS		3	2	152,4	156	865	164	128	825	345	180
TURBOIL-R 127011 S/MMS		3	2	152,4	156	1076	151	114	1036	650	180
TURBOIL-R 128013 S	TURBOIL-R 128013 MMS	3	2	152,4	156	1155	151	114	1115	650	180
TURBOIL-R 129017 S/MMS		3	2	152,4	156	1169	164	128	1129	650	180
TURBOIL-R 815017 S/MMS		3	2	219,1	224	682	195	171	636	90	202
TURBOIL-R 815021 S	TURBOIL-R 815021 MMS	3	2	219,1	224	695	215	185	649	90	202
TURBOIL-R 830025 S	TURBOIL-R 830025 MMS	3	2	219,1	224	709	234	185	664	90	202
TURBOIL-R 1217 S/MMS		3	2	219,1	224	792	195	171	744	205	202
TURBOIL-R 1221 S	TURBOIL-R 1221 MMS	3	2	219,1	224	805	215	185	757	205	202
TURBOIL-R 1225 S	TURBOIL-R 1225 MMS	3	2	219,1	224	819	234	185	772	205	202

<sup>(1)</sup> Chapter «Connection features and drawings» (refer to chapter 114).

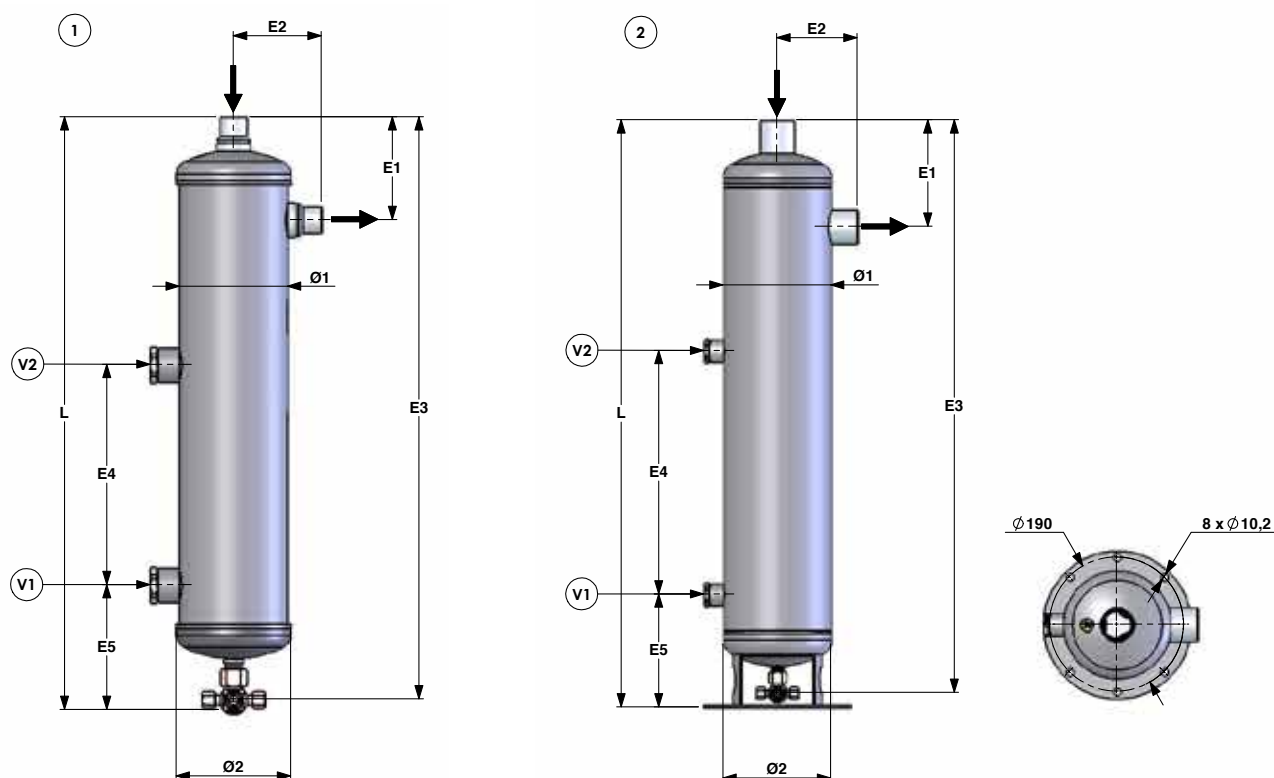



## Oil separators

### → TURBOIL-R®

#### ■ Technical features

CARLY references	Volume	Volume of the receiver	Volume <sup>(3)</sup>		Maximal working pressure	Working pressure <sup>(1)</sup>	Maximal working temperature	Minimal working temperature	Working temperature <sup>(1)</sup>	CE Category <sup>(2)</sup>	
			V L	VR L							V1 L
TURBOIL-R 22505 S/MMS	3,5	2,3	0,5	2,0	46	15	120	-40	-30	I	
TURBOIL-R 23007 S/MMS	3,5	2,3	0,5	2,0	46	15	120	-40	-30	I	
TURBOIL-R 23009 S	TURBOIL-R 23009 MMS	3,9	2,5	0,5	2,0	46	15	120	-40	-30	I
TURBOIL-R 23011 S/MMS		3,9	2,5	0,5	2,0	46	15	120	-40	-30	I
TURBOIL-R 47009 S	TURBOIL-R 47009 MMS	7,2	4,3	1,4	3,8	46	15	120	-40	-30	II
TURBOIL-R 47011 S/MMS		7,2	4,3	1,4	3,8	46	15	120	-40	-30	II
TURBOIL-R 48013 S	TURBOIL-R 48013 MMS	8,5	4,3	1,4	3,8	46	15	120	-40	-30	II
TURBOIL-R 49017 S/MMS		8,5	4,3	1,4	3,8	46	15	120	-40	-30	II
TURBOIL-R 77011 S/MMS		10,5	7,7	1,4	7,0	46	15	120	-40	-30	II
TURBOIL-R 78013 S	TURBOIL-R 78013 MMS	11,8	7,7	1,4	7,0	46	15	120	-40	-30	II
TURBOIL-R 79017 S/MMS		11,8	7,7	1,4	7,0	46	15	120	-40	-30	II
TURBOIL-R 127011 S/MMS		15,5	12,7	1,4	11,9	46	15	120	-40	-30	II
TURBOIL-R 128013 S	TURBOIL-R 128013 MMS	16,9	12,7	1,4	11,9	46	15	120	-40	-30	II
TURBOIL-R 129017 S/MMS		16,9	12,7	1,4	11,9	46	15	120	-40	-30	II
TURBOIL-R 815017 S/MMS		17,5	7,8	3,1	6,2	45	15	120	-40	-30	II
TURBOIL-R 815021 S	TURBOIL-R 815021 MMS	17,6	7,8	3,1	6,2	45	15	120	-40	-30	II
TURBOIL-R 830025 S	TURBOIL-R 830025 MMS	17,7	7,8	3,1	6,2	45	15	120	-40	-30	II
TURBOIL-R 1217 S/MMS		21,4	11,7	3,1	10,1	45	15	120	-40	-30	II
TURBOIL-R 1221 S	TURBOIL-R 1221 MMS	21,5	11,7	3,1	10,1	45	15	120	-40	-30	II
TURBOIL-R 1225 S	TURBOIL-R 1225 MMS	21,7	11,7	3,1	10,1	45	15	120	-40	-30	II

<sup>(1)</sup> The working pressure is limited to the PS BT value when working temperature is lower than or equal to TS BT value.

<sup>(2)</sup> Classification by volume, according to PED 2014/68/EU (refer to chapter 0).

<sup>(3)</sup> Volume corresponding to sight glasses' level V1 and V2.



CTCY-EN – 42.1-8 / 02-2018

# Oil separators

## → TURBOIL-R®

### ■ Spare parts

CARLY references		Part N°	Description	Quantity
Oil separator receivers	Spare parts			
Complete range TURBOIL-R	CY 35012150	1	Glass without moisture indicator	1
Complete range TURBOIL-R	CY 15552180	2	O-ring PTFE gasket for sight glass	1
Complete range TURBOIL-R	CY 10501000	3	Colour ball for sight glass	1
Complete range TURBOIL-R	CY 15580100	4	Gasket for 3/8" SAE Rotalock valve	1
Complete range TURBOIL-R	CY 19700097	5	3/8" SAE Rotalock valve with gasket	1

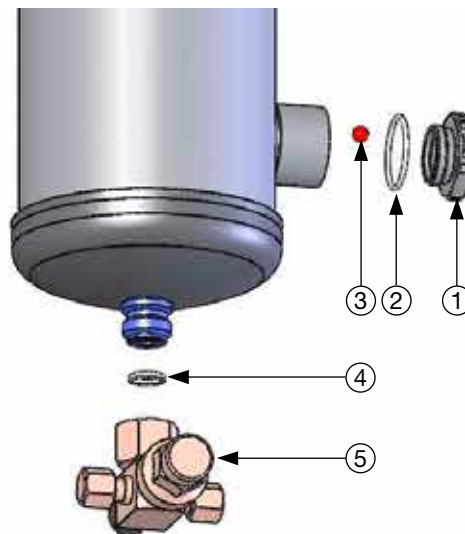





## Oil separators

### → TURBOIL-R®

#### ■ Weights and packaging

CARLY references	Unit weight kg		Packaging number of pieces
	With packaging	Without packaging	
TURBOIL-R 22505 S/MMS	8,20	7,60	1
TURBOIL-R 23007 S/MMS	8,30	7,70	1
TURBOIL-R 23009 S & MMS	8,70	8,10	1
TURBOIL-R 23011 S/MMS	8,80	8,20	1
TURBOIL-R 47009 S & MMS	11,20	10,60	1
TURBOIL-R 47011 S/MMS	11,40	10,80	1
TURBOIL-R 48013 S & MMS	14,80	14,20	1
TURBOIL-R 49017 S/MMS	14,90	14,30	1
TURBOIL-R 77011 S/MMS	14,30	13,70	1
TURBOIL-R 78013 S & MMS	17,40	16,80	1

CARLY references	Unit weight kg		Packaging number of pieces
	With packaging	Without packaging	
TURBOIL-R 79017 S/MMS	17,50	16,90	1
TURBOIL-R 127011 S/MMS	19,00	18,40	1
TURBOIL-R 128013 S & MMS	22,20	21,60	1
TURBOIL-R 129017 S/MMS	22,20	21,60	1
TURBOIL-R 815017 S/MMS	25,40	23,20	1
TURBOIL-R 815021 S & MMS	26,20	24,10	1
TURBOIL-R 830025 S & MMS	26,80	24,60	1
TURBOIL-R 1217 S/MMS	27,00	26,40	1
TURBOIL-R 1221 S & MMS	27,70	27,10	1
TURBOIL-R 1225 S & MMS	28,80	28,20	1