

MAXvent 2

Axial Medium Pressure Fans

02/2009



Copyright © Ziehl-Abegg FMV 2009

ZIEHL-ABEGG FMV reserves the copyright of this catalogue in its entirety. This catalogue is meant for your own use only, and must not be forwarded to third parties without our written consent. The contents of this catalogue, including parts thereof, may not be published. ZIEHL-ABEGG FMV reserves the right to make any technical specification changes without prior notice. The information and data contained within this catalogue have been compiled to the best of our ability. The responsibility for checking the suitability and correct application of the products shown in this catalogue remains with the user.

ZIEHL-ABEGG FMV réserve les droits d'auteur de ce catalogue dans son intégralité. Ce catalogue est destiné à un usage personnel, il ne doit pas être communiqué à un tiers sans notre accord écrit. Le contenu de ce catalogue ne peut pas être publié, même partiellement. ZIEHL-ABEGG FMV se réserve le droit de faire tous les changements techniques de spécifications sans avis préalable. L'information et les données contenues dans ce catalogue ont été compilées au mieux. La responsabilité de vérifier l'adéquation et l'utilisation correcte des produits de ce catalogue appartient à l'utilisateur.

Das Urheberrecht des Katalogs liegt für den gesamten Inhalt ausschließlich bei ZIEHL-ABEGG FMV. Der Katalog ist zur Nutzung für Ihren Bedarf bestimmt und darf ohne unsere ausdrückliche schriftliche Zustimmung weder an Dritte weitergegeben, noch deren Inhalte, auch auszugsweise, veröffentlicht werden. Die im Katalog enthaltenen Informationen und Daten sind nach bestem Wissen erstellt und entbinden Sie nicht von der Pflicht, die Eignung der darin enthaltenen Produkte auf die von Ihnen beabsichtigte Anwendung hin zu prüfen. ZIEHL-ABEGG FMV behält sich alle Technische Änderungen vor.

La compañía ZIEHL-ABEGG FMV se reserva los derechos de autor de este catálogo en su integralidad. Este catálogo está destinado a un uso personal y no debe ser comunicado a terceros sin nuestro acuerdo escrito. El contenido de este catálogo no puede ser publicado ni tan siquiera parcialmente. La compañía ZIEHL-ABEGG FMV se reserva el derecho de introducir cambios técnicos de especificaciones sin aviso previo. La información y los datos contenidos en este catálogo han sido compilados en su mejor estado. La responsabilidad de comprobar la adecuación y la utilización correcta de los productos de este catálogo pertenece al usuario.

ZIEHL-ABEGG FMV riserva i diritti d'autore di questo catalogo nella sua integralità. Questo catalogo è destinato ad un uso personale, non deve essere comunicato ad un terzo senza il nostro accordo scritto. Il contenuto di questo catalogo non può essere pubblicato, anche parzialmente. ZIEHL-ABEGG FMV si riserva il diritto di apportare tutte le modifiche delle specifiche tecniche senza alcuna comunicazione preliminare. Le informazioni ed i dati contenuti in questo catalogo sono state compilate al meglio. La responsabilità di verificare la conformità e l'uso corretto dei prodotti di questo catalogo spetta all'utilizzatore.

Ziehl-Abegg, a progressive company with Tradition

Those who want the best trust in Ziehl-Abegg. Wherever a lift is moving, or buildings or facilities are air conditioned, it's often Ziehl-Abegg's latest technology which is to be found playing its part.

In 1910, Mr. Emil Ziehl established the foundations which enable Ziehl-Abegg's present market leading position in the lift drive motor market sector, as well as the ventilation and air conditioning market sector.

In 1949 after the war, Ziehl-Abegg OHG was newly founded in Kuenzelsau by the brothers Heinz and Guenter Ziehl.

Ziehl-Abegg has always possessed the critical expertise and knowledge required to enable the transfer of technology from one market sector to another, and to understand and respond to customers' needs and requirements. This has resulted in Ziehl-Abegg having a head-start in the market, which continues to this day.

More than 2500 employees are working for Ziehl-Abegg worldwide. Today, nearly a century after Emil Ziehl's pioneering work, the company continues delivering advanced technology in the fields of air movement, motors and motor drives, and electrical controls, from Kuenzelsau to the whole world. In most countries throughout the world, we are represented locally.

With a wide range of top quality products, we offer tailored system solutions to our customers, all from one source. From the beginning to the end, Ziehl-Abegg customers are offered guidance and support in all phases of their projects.



Ziehl-Abegg headquarters, Kuenzelsau



Ziehl-Abegg Medium pressure fan production, Villieu



REFRIGERATION
Coolers, Condensers,
Chillers,
Blast and spiral freezers,
Radiators, Oil coolers,

REFRIGERATION
Ventilateurs,
Condenseurs, Refroidisseurs,
Congélateurs à spirale, soufflant
Radiateurs, Refroidisseurs d'huile

KÄLTETECHNIK
Kühler, Verflüssiger,
Kaltwassersätze, Froster,
Ölkühler, ect

REFRIGERAZIONE
Ventilatori,
Condensatori, Raffreddatori, Congelatori
a spirale, termoventilatori,

REFRIGERACIÓN
Ventiladores,
Condensadores,
Refrigeradores,
Congeladores de
espiral, sopladores,
Radiadores,



AGRICULTURE, FOOD
Grain and rice dryers, forage
Preservation of vegetables, fruits,
flowers, pasta

AGRICULTURE, AGRO-ALIMENTAIRE
Séchage de céréales, fourrage...
Ventilation pour la conservation de légumes, de fruits, de fleurs...
Séchage des pâtes, riz

AGRICULTURA, ALIMENTACIÓN
Secado de cereales, forraje...
Ventilación para la conservación de verduras, fruta, flores...
Secado de pastas, arroz

AGRICOLTURA, AGRO-ALIMENTARE
Essiccamento di cereali, foraggio...
Ventilazione per la conservazione
di verdure, frutta, fiori...
Essiccamento di pasta, riso



LANDWIRTSCHAFT, LEBENSMITTELBEREICH
Trocknen von Getreide und Heu...
Gebläse für die Lagerung von Gemüse, Obst, Blumen...
Trocknen von Nudeln, Reis



INDUSTRIE
Séchage du bois, papier, textile,
Extraction ou introduction d'air
Refroidissement de moteurs

INDUSTRY
Wood dryer, paper, textiles,
Air extraction or introduction
Engine cooler



INDUSTRIA
Secado de madera, papel, textil
Extracción o introducción de aire
Refrigeración de motores

INDUSTRIA
Essiccamento del legno, carta, tessuti,
Estrazione o introduzione dell'aria
Raffreddamento dei motori

INDUSTRIE
Trocknen von Holz, Papier, Stoffen
Luftentzug oder -versorgung
Motorkühlung, Kühlung von Transformatoren



Integration into a ventilation duct

Einbau in ein Rohrsystem

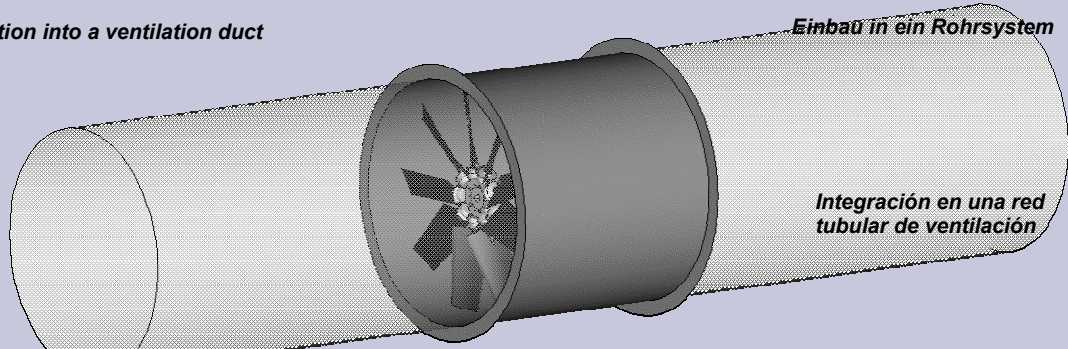

Integración en una red tubular de ventilación

Intégration dans un réseau tubulaire de ventilation

Integrazione in un sistema tubolare di ventilazione

Selection		7
English Technical Documentation		8
Documentation technique Française		12
Deutsche technische Dokumentation		16
Documentación técnica española		20
Documentazione tecnica Italiano		24
Standard temperature range : -30°C / +50°C		28

FV31	2/4 poles / pôles / polig / polos / poli	29
FV35	2/4 poles / pôles / polig / polos / poli	31
FV40	2/4/6 poles / pôles / polig / polos / poli	33
FV45	2/4/6 poles / pôles / polig / polos / poli	36
FV50	2/4/6 poles / pôles / polig / polos / poli	39
FV56	4/6 poles / pôles / polig / polos / poli	42
FV63	4/6/8 poles / pôles / polig / polos / poli	44
FV71	4/6/8 poles / pôles / polig / polos / poli	47
FV80	4/6/8 poles / pôles / polig / polos / poli	50
FV90	4/6/8 poles / pôles / polig / polos / poli	53
FV10	4/6/8 poles / pôles / polig / polos / poli	56
FV12	4/6/8 poles / pôles / polig / polos / poli	59
FV14	6/8 poles / pôles / polig / polos / poli	62

Increased Temperature Range : -30°C / +60°C **64**

FV31	2/4 poles / pôles / polig / polos / poli	65
FV35	2/4 poles / pôles / polig / polos / poli	67
FV40	2/4/6 poles / pôles / polig / polos / poli	69
FV45	2/4/6 poles / pôles / polig / polos / poli	72
FV50	2/4/6 poles / pôles / polig / polos / poli	75
FV56	4/6 poles / pôles / polig / polos / poli	78
FV63	4/6/8 poles / pôles / polig / polos / poli	80
FV71	4/6/8 poles / pôles / polig / polos / poli	83
FV80	4/6/8 poles / pôles / polig / polos / poli	86
FV90	4/6/8 poles / pôles / polig / polos / poli	89
FV10	4/6/8 poles / pôles / polig / polos / poli	92
FV12	4/6/8 poles / pôles / polig / polos / poli	95
FV14	6/8 poles / pôles / polig / polos / poli	98

Accessories / Accessoires / Zubehör / Accesorios / Accessori **100**

Axial Fan Definition **103**



ISO 9001:2000



GOST



CCC

Quick selection:
Air-flow / Static Pressure

Sélection rapide:
Débit / pression statique

Schnellauswahl:
Volumenstrom/ Statischer Gesamtdruck

Selección rápida:
Caudal / Presión estática

Selezione rapida:
Portata / pressione statica

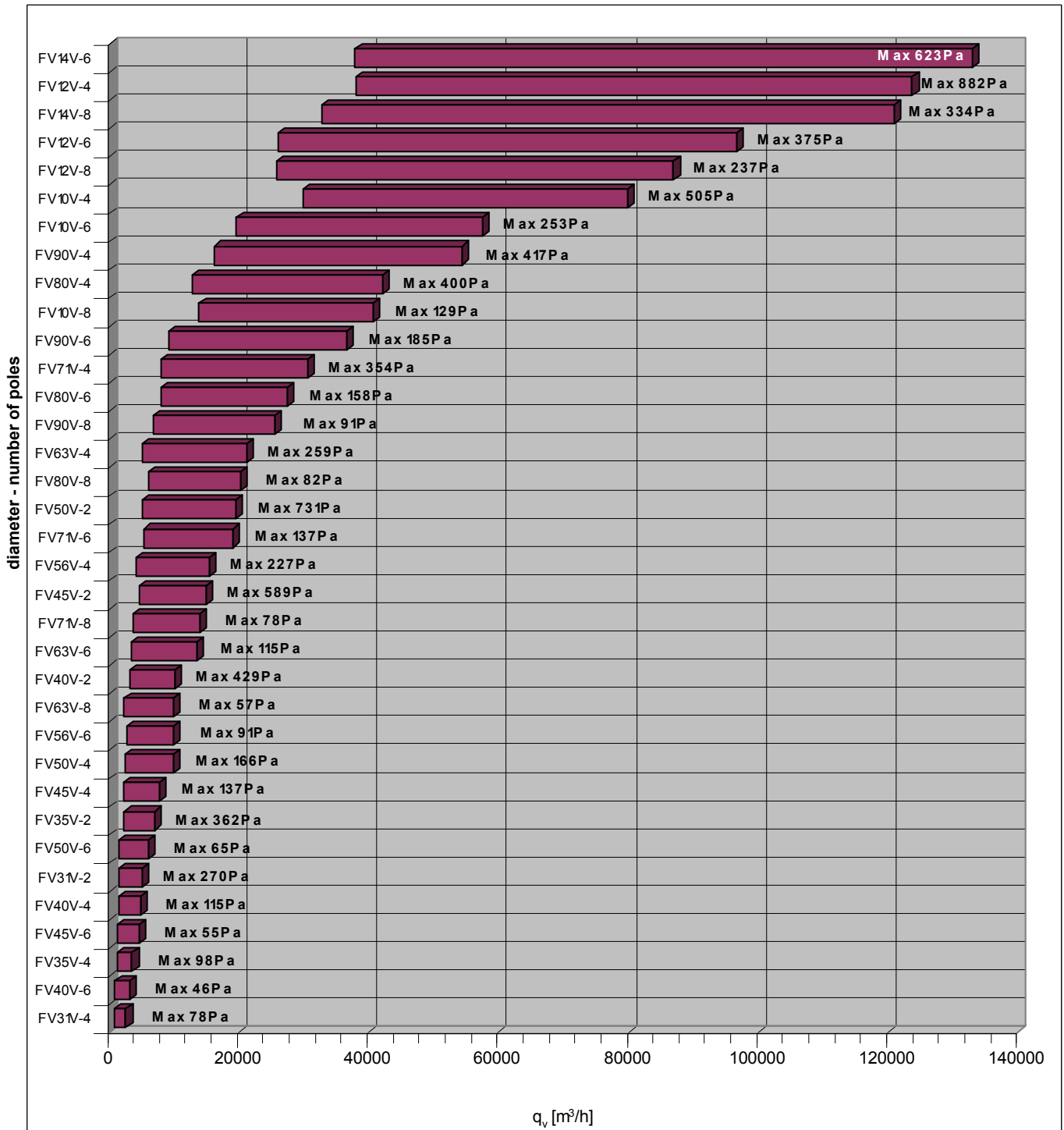
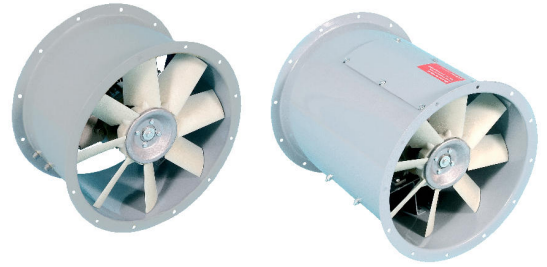



The MAXvent 2 Range

The MAXvent 2 range is the evolution of a proven existing axial medium pressure range, in response to the actual market requirements in terms of aeraulic performances, low noise level and breadth of range.

We offer two configurations in standard, short and long casing designed to the EUROVENT standard dimensions. Thanks to the efficient design and proven components, we can ensure the high quality and reliability of the MAXvent 2 range of fans.

We have been working countless hours and still are, in order to improve day after day our range of fans and bring you the best performances and highest reliability. Answering your technical requirements and needs is our goal.

Technical description

The axial MAXvent 2 range fans are constructed with impellers made of glass reinforced polyamide blades (PAG) and aluminium alloy hubs. These impellers have been designed for applications needing products capable of working at a total pressure of 1000 Pa. According to the pressure drop of your application, diameter and speed of the selected fan, available airflow goes up to 130 000 m³/h.

Airflow measurements are done according to ISO 5801 standard

A wide range:

The MAXvent 2 axial range fans are available in 13 diameters: 315, 355, 400, 450, 500, 560, 630, 710, 800, 900, 1000, 1250 and 1400 mm.

MAXvent 2 axial range fans are constructed with standard asynchronous internal rotor motors, conforming to the IEC standards. These motors are a B3 type of construction, IP55 and class F, with PTC thermistors.

They are available in three-phase 230/400V 50Hz up to 2,2kW and 400VΔ above.

Depending on the diameter, the motors are available in 2, 4, 6 or 8 poles configurations.

For each diameter and each speed of rotation, the range includes 5 impeller blade angles – a total of almost 175 possible combinations to satisfy any request:

Ø	2 poles	4 poles	6 poles	8 poles
315	√	√		
355	√	√		
400	√	√	√	
450	√	√	√	
500	√	√	√	
560		√	√	
630		√	√	√
710		√	√	√
800		√	√	√
900		√	√	√
1000		√	√	√
1250		√	√	√
1400			√	√

Depending on your requirements, we propose to you several constructions: either short casing, long casing or square plate with specific dimensions, for installation in ducted systems or for use with industrial processes.

All the components in the MAXvent 2 range are protected against corrosion and can be painted on request.

Standard Configurations

The MAXvent 2 standard versions are constructed with:

- Impellers made with glass reinforced polypropylene blades, selected by us for your application and balanced according to IEC 14694 standard (G = 6.3)
- IEC B3 lug-mounted motors, SIEMENS or similar brand (cable gland not supplied)
- Steel Casings.

The fans are supplied on pallets

There are two anti-corrosion finishes:

- Pre-galvanized steel
- Hot dip galvanized steel

These fans can operate either horizontally or vertically and are available in both airflow directions.

The fans are directly coupled: the impeller is mounted directly on the motor shaft.

In the standard configuration, they can be used in any application with clean air in a dust free environment.

The temperature of the airflow should be between –30 °C and +50 °C for fans in the “Standard temperature range” section and between –30 °C and +60°C for fans in the “Increased Temperature Range” section.

Accessories:

Speed controllers, mounting feet, Anti-vibration mounts, matching flanges, inlet bell mouth, flexible connector, protective grilles (impeller or motor side).

Special Configurations

Ziehl-Abegg FMV can offer special configurations which answers specific needs, such as:

- Square plate design for all diameters, with dimensions adapted to the application.
- Stainless steel 304 or 316L or polyester powder paint finish
- Impeller with aluminium blades or glass reinforced polypropylene blades (PPG)
- Motor
 - EFF1
 - 2 speeds (star/delta or Dahlander)
 - 60Hz
 - PTO thermistors
 - High or low temperatures
 - Terminal box remotely mounted on the casing
 - All IEC motors options
 - And many other possibilities

We study any request concerning non standard products. ...Don't hesitate to ask us!



The MAXvent 2 Range

Explanation

- 1 Fan
- 2 Air Flow
- 3 Fan static pressure
- 4 Pitch angle
- 5 Frequency
- 6 Motor size
- 7 Voltage
- 8 Current
- 9 Rated power
- 10 Rated speed
- 11 Suction side sound pressure level @ 3m
- 12 Design
- 13 Relative sound power level spectrum
- 14 Accessories
- 15 Temperature range

FV31V-2D _____

50Hz	Motor	U	I	P ₂	n
	V	A	kW	min ⁻¹	
25°	71 M	400	1	0,37	2740
30°	71 M	400	1	0,37	2740
35°	71 M	400	1,36	0,55	2800
40°	71 M	400	1,36	0,55	2800
45°	80 M	400	1,73	0,75	2855

Pitch Angle	Relative spectrum							
	63	125	250	500	1000	2000	4000	8000
25°	-42	-33	-15	-7	-4	-6	-11	-20
30°	-41	-32	-15	-7	-4	-6	-10	-19
35°	-40	-31	-15	-7	-4	-5	-9	-18
40°	-40	-31	-15	-7	-4	-5	-9	-17
45°	-39	-30	-16	-8	-4	-5	-8	-17

Accessories : see pages 100-102

Standard Temperature Range : -30°C / +50°C

Designation

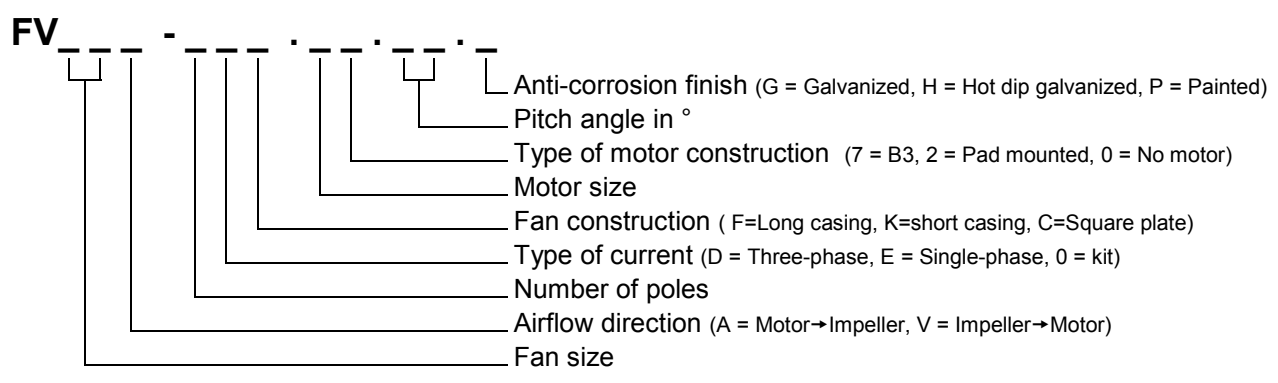



The MAXvent 2 Range

Aeraulic measurements:

Fan characteristic curves show a Δp_{sf} pressure increase in Pa as a function of airflow in m^3/h

Aeraulic tests were conducted as per ISO5801 in our laboratories ("Invent" laboratory in Germany and ZA-FMV laboratory in France).

A complete set of measurements taken in our laboratories enabled us to establish the curves presented below.

Measurements were taken in type A and type D and results show that variations between the 2 measurements are within the range of tolerances measured.

Some tests were corroborated by the CETIAT (approved French laboratory)

The fan is installed in a measurement box with free intake and outflow.

Measurements were taken without a safety guard.

Acoustic measurements:

Acoustic tests were conducted as per ISO13347 and ISO5136. Acoustic powers with A weighting in L_w are calculated from acoustic pressure levels in octave bands measured at the suction side of the fan.

Sound level pressures are measured according to the 9-point enveloping surface method over a hemispherical surface, as described in the ISO 13347-3 standard

A weighting uses an octave band correction to allow for the sensitivity of the human ear to certain frequencies.

To obtain the acoustic power level of a fan from the acoustic pressure level at 3 metres, the following formula can be used:

$$L_w = L_p (@ 3m) + 10 \cdot \text{Log} (2 \cdot \pi \cdot R^2) + 20 \cdot \text{Log} (3), \quad \text{where } R = 1$$

To obtain the acoustic power level as a function of the octave range spectrum, the following formula can be used:

$$L_w = 10 \cdot \text{Log} \left(\sum 10^{(0.1 \cdot L_{wi})} \right), \quad \text{where } i = \text{octave band}$$

Caution: some national measurement standards (e.g. BS 848) use measurements taken at distances different from those used in the ISO standards. Depending on the fan size, the sound data obtained is likely to be significantly lower than the one found when measured according to the ISO standards.

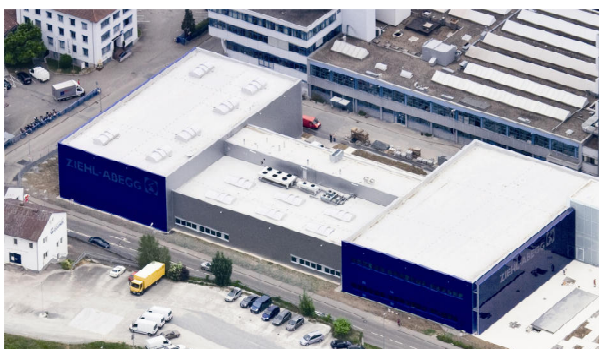

« Invent » Laboratory, Ziehl-Abegg AG, Germany

The MAXvent 2 Range



General tolerances:

- On flow rates : $\pm 5\%$ of nominal flow rate
- On acoustic power and pressure levels : $\pm 3\text{dB}$
- By octave band: $\pm 5\text{dB}$

Air Inlet bellmouth and its effect on aeraulic and acoustic measurements:

Tests were conducted with an optimised bellmouth designed to:

- Minimise integration effects responsible for reduced airflow and for the appearance of a stall point at a lower pressure than specified.
- Optimise the motor consumption
- Minimise integration and stall noise

Moreover, it is important to ensure proper air intake when the fan is installed by allowing a minimum integration distance equivalent to approximately one fan's diameter.

Acoustic system effect and safety guard:

Safety distances to prevent access to hazardous areas are specified in the EN 294 standard .

The use of safety guards is recommended for this purpose. Guards generate resistance to air flow that represents a pressure loss Δp_{sf} for the fan. Pressure loss increases with the square of the fan flow rate.

Fan electrical consumption and sound level are also affected. Guards are proposed as accessories.

Safety information:

The Ziehl-Abegg axial fans are designed to operate inside systems and are merely components of these systems.

The machine manufacturer must satisfy equipment or system safety specifications as per the EN 294 standard .

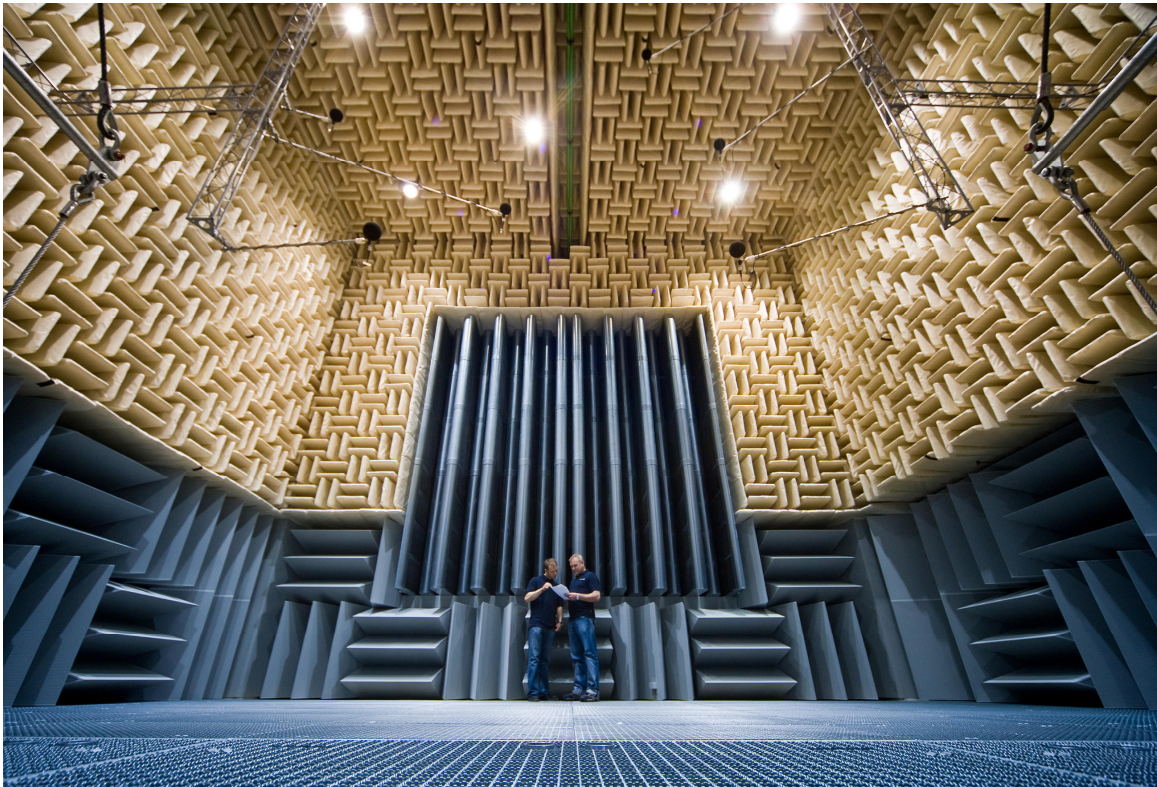

« Invent » Laboratory, Ziehl-Abegg AG, Germany



La gamme MAXvent 2

La gamme MAXvent 2 est née d'une part d'une gamme existante depuis plusieurs années dans le domaine de la ventilation moyenne pression, et d'autre part des efforts des équipes ZIEHL-ABEGG FMV pour répondre à vos besoins spécifiques en terme de performance aéraulique, de faible niveau sonore, d'avantages techniques et de largeur de gamme.

Deux configurations sont proposées en standard : virole courte et virole longue aux dimensions de la norme EURO-VENT. Grâce à son design éprouvé et aux composants de marque utilisés, nous pouvons garantir la qualité et la fiabilité des ventilateurs de la gamme MAXvent 2.

Nous consacrons aujourd'hui comme hier nos ressources à l'amélioration de nos gammes de ventilateurs dans le but de vous fournir le maximum de performance et de satisfaire l'ensemble de vos exigences techniques.

Description technique

La gamme de ventilateurs hélicoïdes MAXvent 2 est équipée d'une hélice avec des pales en polyamide renforcé fibre de verre (PAG) et un moyeu en alliage d'aluminium (fonderie) conçue pour des applications allant jusqu'à des pressions totales de 1000 Pa selon le diamètre.

En fonction de la perte de charge de votre installation, du diamètre et de la vitesse de l'hélice sélectionnée le débit disponible peut atteindre 130 000 m³/h .

Les débits sont mesurés selon ISO 5801.

Une large gamme:

La gamme MAXvent 2 est disponible en 13 diamètres : 315, 355, 400, 450, 500, 560, 630, 710, 800, 900, 1000, 1250 et 1400 mm.

Les ventilateurs de la gamme MAXvent 2 sont équipés de moteurs asynchrones à rotor intérieur normalisés (IEC). Il s'agit de moteurs à pattes B3, IP55, classe F disponibles en triphasé 230/400V 50Hz jusqu'à 2,2kW et 400/690V 50Hz au-delà avec protection par thermistances PTC.

Selon le diamètre, les moteurs sont disponibles en 2 pôles, 4 pôles, 6 pôles ou 8 pôles.

Pour chaque diamètre et chaque vitesse de rotation la gamme comporte 5 angles d'hélice, au total 175 combinaisons possibles afin de répondre à toutes les demandes:

Ø	2 pôles	4 pôles	6 pôles	8 pôles
315	√	√		
355	√	√		
400	√	√	√	
450	√	√	√	
500	√	√	√	
560		√	√	
630		√	√	√
710		√	√	√
800		√	√	√
900		√	√	√
1000		√	√	√
1250		√	√	√
1400			√	√

En fonction de votre besoin, nous pouvons vous proposer une solution en virole courte ou longue ou une solution sur plaque carrée aux dimensions adaptées à votre besoin que ce soit en application en gaine ou en application process industriel.

Par ailleurs sont disponibles sur demande toutes les options des moteurs normalisés.

Tous les composants des ventilateurs de la gamme MAXvent 2 sont protégés contre la corrosion et peuvent être peints sur demande.

Configurations standard

La gamme de ventilateurs MAXvent 2 est équipée:

- d'une hélice en matériau composite sélectionnée par nos soins pour votre application et équilibrée selon les prescriptions de la norme ISO 14694 (G = 6.3)
- d'un moteur IEC à pattes B3 de marque SIEMENS ou similaire (presse-étoupe non fourni)
- d'une virole en acier .

Conditionnement sur palette.

Deux finitions anticorrosion :

- Casing en acier galvanisé ou zingué
- Casing en acier galvanisé à chaud

Ces ventilateurs peuvent fonctionner indifféremment, axe horizontal ou vertical et sont disponibles pour les deux sens de flux d'air.

Ces ventilateurs sont en accouplement direct: l'hélice directement placée en bout d'arbre du moteur.

Ils peuvent être utilisé en application standard dans toutes applications où l'air véhiculé est propre, non poussiéreux.

La température du flux d'air doit être comprise entre -30°C et +50°C pour les ventilateurs de la section "Standard temperature range" et -30°C et +60°C pour les ventilateurs de la section "Increased Temperature Range" .

Accessoires

Variateurs de vitesse, pieds de montage, plots anti-vibratiles, viroles d'entrée d'air, contre-bridés, viroles élastiques, grilles de protection (côté hélice ou côté moteur).

Configurations spéciales

Ziehl-Abegg FMV peut offrir des configurations sur mesure qui répondent au mieux aux besoins de ses clients tel que :

- Construction avec plaque carrée (tous diamètres) adaptée à l'environnement du client
- Construction en acier inoxydable (304 ou 316L) ou finition peinture poudre polyester
- Hélice avec pale aluminium ou polypropylène chargé fibre de verre (PPG)
- Moteur
 - EFF1
 - 2 vitesses (bobinages séparés ou Dahlander)
 - 60Hz
 - Thermistances PTO
 - Utilisation basse ou haute température
 - Boite à bornes déportée sur la virole
 - Toutes les options des moteurs IEC
 - Et beaucoup d'autres possibilités

Nous étudions toute demande différente de nos produits standard.

... Consultez nous!

La gamme MAXvent 2



Légende

- 1 Ventilateur
- 2 Débit d'air
- 3 Pression statique
- 4 Angle d'hélice
- 5 Fréquence
- 6 Taille moteur
- 7 Tension
- 8 Intensité
- 9 Puissance nominale
- 10 Vitesse de rotation
- 11 Niveau de pression sonore @ 3m
- 12 Construction du ventilateur
- 13 Spectre relatif de puissance acoustique
- 14 Accessoires
- 15 Plage de température

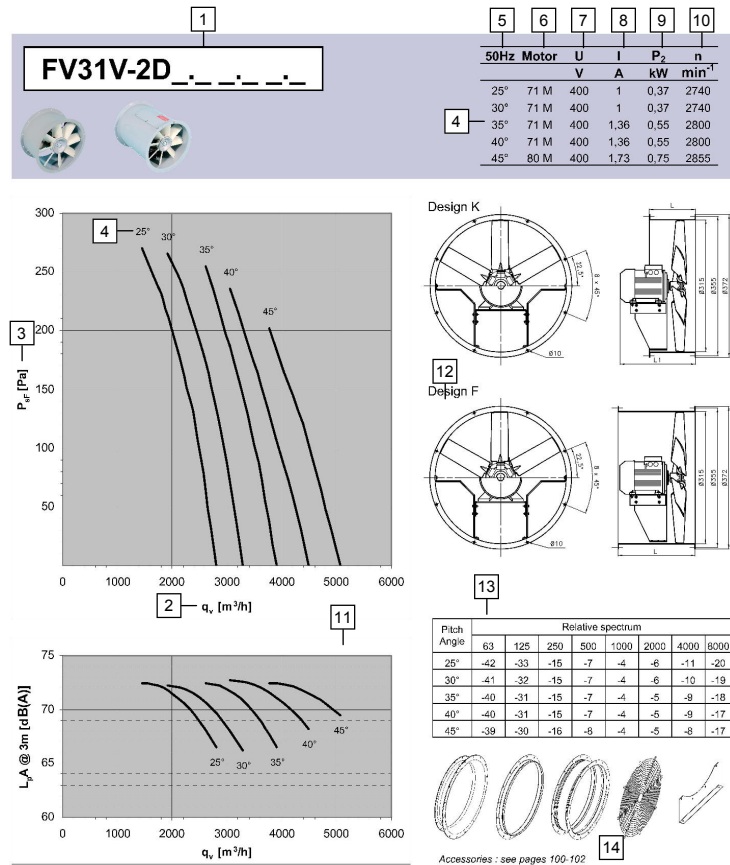

Standard Temperature Range : -30°C / +50°C

Désignation

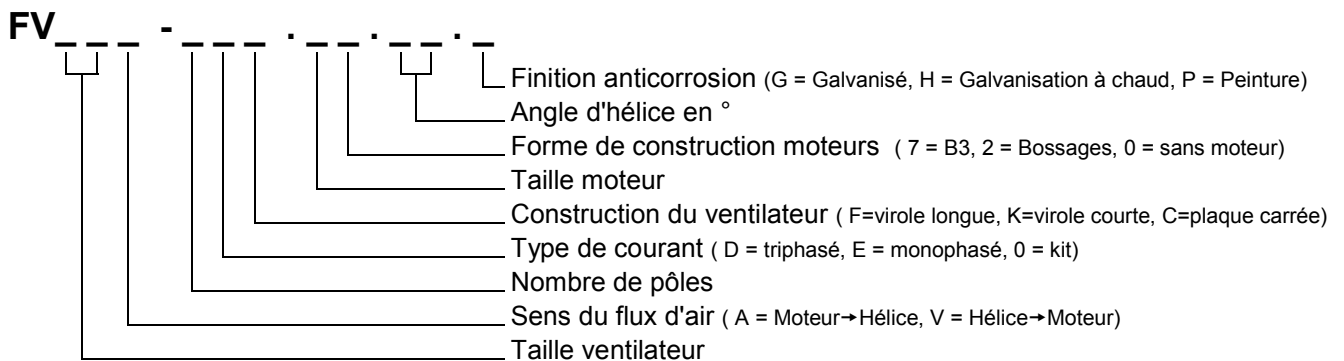

La gamme MAXvent 2



Mesures aérauliques:

Les courbes caractéristiques du ventilateur montrent l'augmentation de pression ΔP_{sf} en Pa en fonction du débit en m^3/h .

Les tests ont été réalisés suivant ISO5801 pour l'aéraulique et au sein de nos laboratoires (laboratoire "Invent" en Allemagne et laboratoire ZA-FMV en France).

Tout un ensemble de mesures effectuées dans nos laboratoires nous ont permis d'établir les courbes présentées ci-après.

Des mesures ont été réalisées en type A et en type D et les résultats montrent que les variations entre les 2 mesures sont dans la plage de tolérances mesures.

Certains tests ont été corroborés par le CETIAT (laboratoire français agréé).

Le ventilateur est installé dans un caisson de mesures à entrée et sortie libres.

Les mesures ont été menées sans grille de protection.

Mesures acoustiques:

Les tests ont été réalisés suivant ISO13347 et ISO5136 pour l'acoustique.

Les puissances acoustiques pondérées A en L_w sont calculées à partir de niveaux de pression acoustique en bandes d'octave mesurées à l'aspiration du ventilateur.

Les pressions de niveau sonore sont mesurées selon la méthode de la surface enveloppante en 9 points sur une surface hémisphérique décrite dans la norme ISO 13347-3

La pondération A tient compte de la sensibilité de l'oreille humaine à certaines fréquences par une correction en bande d'octave.

Détermination du niveau de puissance acoustique d'un ventilateur à partir du niveau de pression acoustique à 3 mètres:

$$L_w = L_p(@ 3m) + 10 \cdot \text{Log}(2 \cdot \pi \cdot R^2) + 20 \cdot \text{Log}(3), \quad \text{avec } R = 1$$

Détermination du niveau de puissance acoustique en fonction du spectre en gamme d'octaves:

$$L_w = 10 \cdot \text{Log} \left(\sum 10^{(0.1 \cdot L_{wi})} \right), \quad \text{avec } i = \text{bandes d'octaves}$$

Attention certains anciens standards nationaux de mesures (ex BS 848) font appel à des mesures effectuées à des distances différentes des normes en vigueur. Ces anciens standards peuvent conduire à des valeurs acoustiques minorées de façon significative selon la taille du ventilateur.

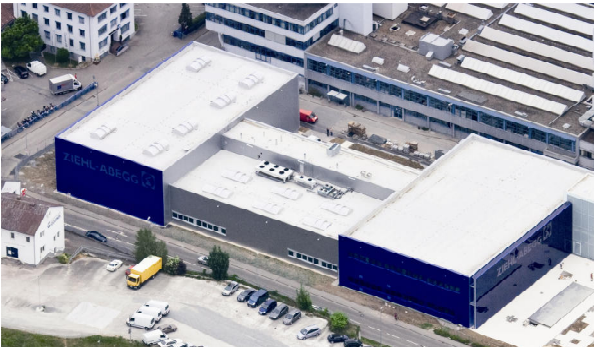

Laboratoire "Invent", Ziehl-Abegg AG, Allemagne

La gamme MAXvent 2



Tolérances générales:

- Sur les débits : $\pm 5\%$ du débit nominal
- Sur les niveaux de pression et de puissance acoustique : $\pm 3\text{dB}$
- Par bande d'octave : $\pm 5\text{dB}$

Viroles d'entrée d'air et ses effets sur l'aéroulque et l'acoustique :

Les essais ont été effectués avec un pavillon d'entrée d'air optimisé permettant :

- De minimiser les effets d'intégration responsables de la diminution du débit et de l'apparition d'un point de pompage à une pression plus basse que prévue.
- D'optimiser la consommation du moto-ventilateur
- De minimiser le bruit d'intégration et de pompage

Par ailleurs il est important d'assurer une bonne entrée d'air quand le ventilateur est installé en respectant une distance minimum d'environ 1 fois le diamètre du ventilateur.

Effet système acoustique et grille de protection :

Les distances de sécurité pour prévenir l'accessibilité avec les zones dangereuses sont spécifiées dans la norme EN 294. Dans ce but nous préconisons l'utilisation de grilles protectrices.

Les grilles occasionnent une résistance au passage du flux d'air qui représente une perte de pression ΔP_{sf} pour le ventilateur, cette perte de pression augmente avec le carré du débit du ventilateur.

La consommation électrique et le niveau sonore du ventilateur sont également affectés.

Les grilles de protection sont proposées en tant qu'accessoires.

Information sur la sécurité :

Les ventilateurs axiaux Ziehl-Abegg sont conçus pour fonctionner à l'intérieur de systèmes et ne sont que des composants de ces systèmes

Le fabricant de la machine doit répondre aux spécifications de sécurité des équipements ou du système selon la norme EN 294.

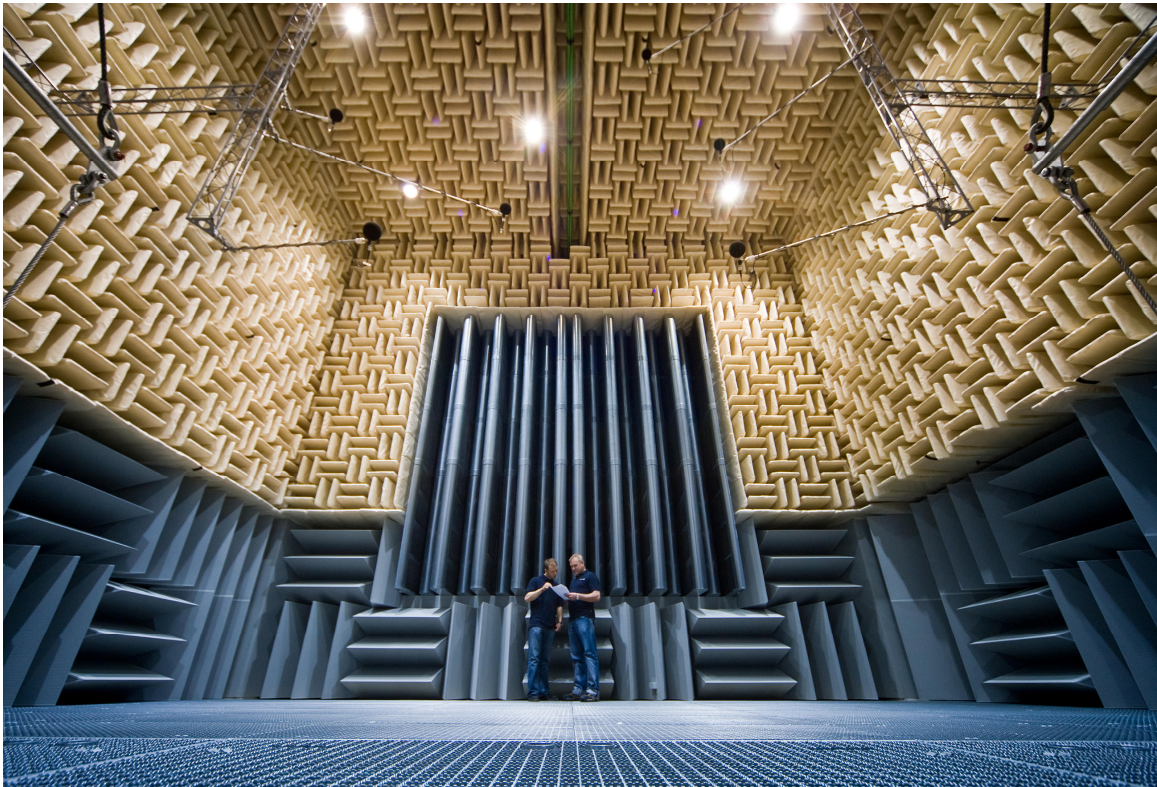

Laboratoire "Invent", Ziehl-Abegg AG, Allemagne

Produktreihe MAXvent 2



Die Produktreihe MAXvent 2 baut zum einen auf eine seit mehreren Jahren bestehenden Produktreihe im Bereich der Mitteldruckventilatoren auf. Zum anderen ist sie Ausdruck unseres Engagements, auf den spezifischen Bedarf unserer Kunden in den Bereichen Luftleistung, geringen Schallpegels, technischer Optimierungen und Umfang der Produktreihe einzugehen.

Standardmäßig werden zwei Ausführungen angeboten: kurzes und langes Rohrgehäuse entsprechend den Maßen der EUROVENT-Norm. Durch sein anerkanntes Design und seine hochwertigen Komponenten können wir für die Qualität und Zuverlässigkeit der Ventilatoren unserer Produktreihe MAXvent 2 garantieren.

Wir investieren kontinuierlich in die Verbesserung unserer Ventilatoren mit dem Ziel, Ihnen maximale Leistung zur Verfügung zu stellen und Ihren gesamten technischen Anforderungen zu entsprechen.

Technische Beschreibung

Die Produktreihe der MAXvent 2 Ventilatoren ist mit einem Laufrad aus durch Glasfaser verstärktem Polyamid (PAG) und einer Nabe aus einer Aluminium-Druckguss ausgestattet. Dieses wurde speziell für Applikationen entwickelt, bei denen je nach Durchmesser ein Gesamtdruck von bis zu 1000 Pa auftritt.

Je nach Druckabfall Ihrer Installation, Durchmesser und Geschwindigkeit des gewählten Laufrads kann die verfügbare Luftleistung bis zu 130 000 m³/h erreichen. Die Leistung wird gemäß ISO 5801 bemessen.

Eine umfangreiche Produktreihe:

Die Produktreihe MAXvent 2 besteht aus 13 Durchmessern: 315, 355, 400, 450, 500, 560, 630, 710, 800, 900, 1000, 1250 und 1400 mm.

Die Ventilatoren der Produktreihe MAXvent 2 sind mit genormten asynchronen Innenläufermotoren (IEC) ausgestattet. Es handelt sich um B3 Fußmotoren, IP55, Klasse 5, die bis zu 2,2kW dreiphasig mit 230/400 V 50 Hz und darüber mit 400/690 V 50 Hz mit PTC Thermistoren (Kaltleiter) verfügbar sind.

Je nach Durchmesser sind die Motoren 2-, 4-, 6- oder 8-polig erhältlich.

Für jeden Durchmesser und jede verfügbare Drehzahl umfasst die Produktreihe 5 Anstellwinkel, insgesamt also an die 175 mögliche Kombinationen, um auf jeden Bedarf eingehen zu können:

Ø	2 polig	4 polig	6 polig	8 polig
315	√	√		
355	√	√		
400	√	√	√	
450	√	√	√	
500	√	√	√	
560		√	√	
630		√	√	√
710		√	√	√
800		√	√	√
900		√	√	√
1000		√	√	√
1250		√	√	√
1400			√	√

Je nach Bedarf können wir Ihnen eine Lösung mit kurzem oder langem Rohrkanal oder auch eine Lösung auf quadratischer Platte entsprechend den von Ihnen gewünschten Dimensionen anbieten, egal ob es sich um eine Anwendung in einem Rohrsystem oder um eine industrielle Prozessapplikation handelt.

Auf Anfrage sind alle typischen Optionen für genormte Motoren erhältlich.

Alle Komponenten der Ventilatoren der MAXvent 2 Produktreihe sind korrosionsgeschützt und können auf Anfrage beschichtet werden.

Standardausführungen

Die MAXvent 2 Ventilatorproduktreihe ist ausgestattet mit:

- einem Laufrad aus Verbundstoff, das wir entsprechend Ihrer Anwendung sorgfältig auswählen und gemäß den Vorschriften der Norm ISO 14694 (G = 6,3) wuchten
- einem B3 Fußmotor IEC der Marke SIEMENS oder gleichwertig (Kabelverschraubungen sind nicht enthalten)
- einem Rohrkanal aus Stahl

Lieferung auf Palette.

Die Gehäuse werden entweder aus verzinktem Stahl oder aus feuerverzinktem Stahl gefertigt.

Die Ventilatoren können sowohl mit waagrechter als auch mit senkrechter Achse betrieben werden. Beide Luftförderrichtungen sind erhältlich. Das Rad befindet sich auf der Antriebswelle des Motors und wird somit direkt angetrieben.

MAXvent 2 Ventilatoren können für alle Standardapplikationen angewendet werden, bei denen die bewegte Luft sauber und staubfrei ist.

Die Fördermitteltemperatur liegt bei den Ventilatoren der Gruppe "Standard temperature range" zwischen -30° C und +50°C, bei den Ventilatoren der Gruppe "Increased Temperature Range" sind Temperaturen zwischen -30°C und +60°C zulässig.

Zubehör

Drehzahlregler, Montagefüße, Schwingungsdämpfer, Einstromdüsen, Gegenflansche, elastische Stutzen, Schutzgitter (Laufradseite oder Motorseite).

Sonderausführungen

Ziehl-Abegg FMV kann spezifische Ausführungen anbieten, die genau auf die Anforderungen der Kunden abgestimmt sind:

- Fertigung mit quadratischer Platte (alle Durchmesser) in kundenspezifischen Design
- Fertigung aus rostfreiem Edelstahl (304 oder 316L) oder Lackierung mit Polyester
- Laufrad mit Aluminiumschaufeln oder aus mit Glasfaser verstärktem Polypropylen (PPG)
- Motor
 - EFF1
 - 2 Drehzahlen (separate Wicklungen oder Dahlander)
 - 60 Hz
 - PTO-Thermokontakte
 - Anwendung bei niedriger oder hoher Temperatur
 - Klemmkasten außen am Rohrkanal
 - Alle Optionen der IEC-Motoren
 -

Wir sind gerne bereit, Ihre spezifischen Anforderungen zu untersuchen. Stellen Sie uns auf die Probe!

Produktreihe MAXvent 2



Legende

- 1 Typ
- 2 Volumenstrom
- 3 Statische Druckerhöhung
- 4 Anstellwinkel
- 5 Frequenz
- 6 Motor-Baugröße
- 7 Bemessungsspannung
- 8 Bemessungsstrom
- 9 Bemessungsleistung
- 10 Bemessungsdrehzahl
- 11 Schalldruckpegel @ 3m
- 12 Ventilator-Bauform
- 13 Spektrum relative Schalleistungspegel
- 14 Zubehör
- 15 Bereich der maximal zulässigen Fördermitteltemperatur

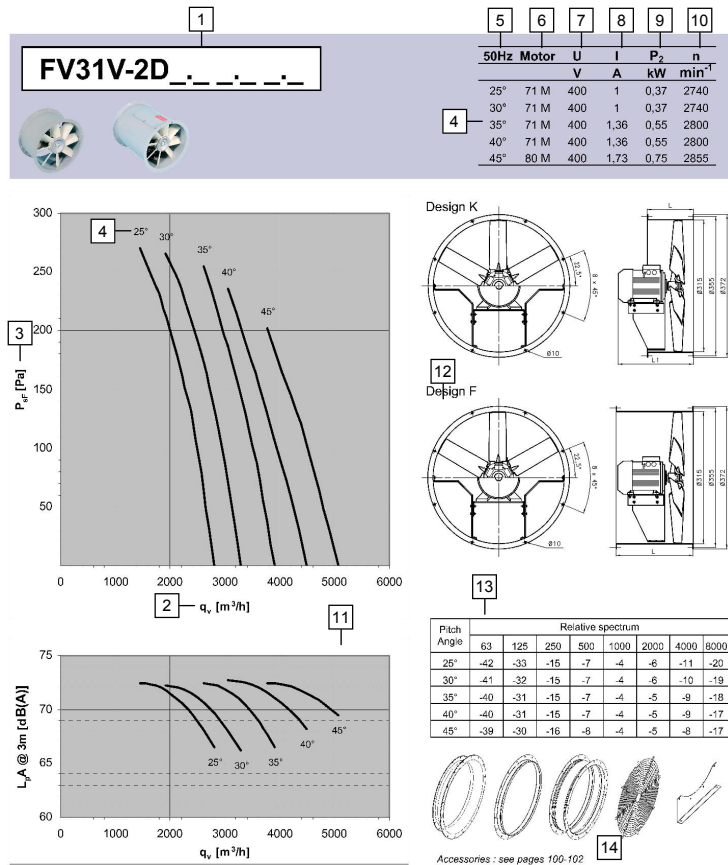

Standard Temperature Range : -30°C / +50°C

Typenschlüssel

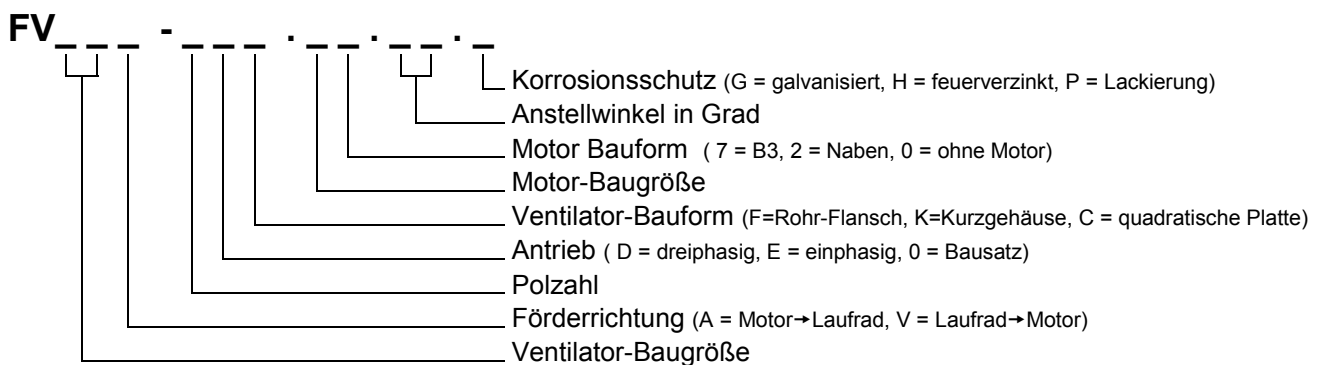

Produktreihe MAXvent 2



Luftmessungen:

Die Ventilator Kennlinien zeigen die statische Druckerhöhung Δp_{st} in Pa als Funktion des Volumenstroms in m^3/h .

Die nachstehend dargestellten Kennlinien konnten auf Grund von zahlreichen Messungen aufgestellt werden.

Die Tests wurden gemäß Norm ISO5801 für Lufttechnik in unseren Labors durchgeführt (Labor "Invent" in Deutschland und Labor ZA-FMV in Frankreich)

Die Messungen erfolgten nach Einbauart Typ A und Typ D und die Ergebnisse zeigen, dass die Unterschiede zwischen den 2 Messmethoden innerhalb der Toleranzen für Messungen liegen.

Einige Test wurden durch den CETIAT (zertifiziertes französisches Labor) bestätigt.

Der Ventilator ist frei ansaugend, frei ausblasend an die Meßkammer angebaut. Die Messungen wurden ohne Schutzgitter durchgeführt.

Akustische Messungen:

Die Tests wurden gemäß Norm ISO13347 und ISO5136 für Akustik durchgeführt.

Die im Katalog in LP angegebenen A-gewichteten Schalldruckpegel werden berechnet auf der Basis von Schalldruckpegeln, die in Oktavbändern an der Saugseite des Ventilators gemessen werden.

Die Schalldruckpegelmessungen erfolgen nach dem Hüllflächenverfahren an 9 Punkten auf einer halbkugelförmigen Fläche, die in der Norm ISO 13347-3 beschrieben ist.

Die Gewichtung A berücksichtigt durch eine Korrektur im Oktavband die Empfindlichkeit des menschlichen Ohres auf bestimmte Frequenzen.

Ermittlung des Schalleistungspegels eines Ventilators ausgehend vom Schalldruckpegel in einem Abstand von 3 Metern:

$$L_w = L_p (@ 3m) + 10 \cdot \text{Log} (2 \cdot \pi \cdot R^2) + 20 \cdot \text{Log} (3), \quad \text{mit } R = 1$$

Ermittlung des Schalleistungspegels in Abhängigkeit des Spektrums im Oktavband:

$$L_w = 10 \cdot \text{Log} \left(\sum 10^{(0.1 \cdot L_{wi})} \right), \quad \text{mit } i = \text{Oktavband}$$

Anmerkung: Bei einigen nationalen Messnormen (z. B. BS 848) erfolgen die Messungen in Abständen, die sich von den gängigen geltenden Normen unterscheiden können. Dadurch können sich je nach Ventilatorgröße erhebliche Minderungen der ermittelten Schalldruckpegel ergeben.

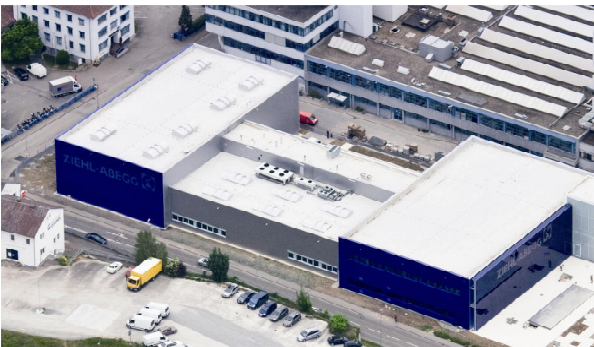

Labor "Invent", Ziehl-Abegg AG, Deutschland



Allgemeine Toleranzen:

- Förderleistung: $\pm 5\%$ der Nennleistung
- Schalldruck- und Schalleistungspegel: $\pm 3\text{dB}$
- Pro Oktavband: $\pm 5\text{dB}$

Einströmdüse und dessen Auswirkung auf Luftleistung und Akustik:

Die Tests wurden mit einer optimierten Einströmdüse durchgeführt. Dadurch konnten:

- Die Integrationseffekte minimiert werden. Diese führen zu einer Verminderung des Volumenstroms und zum Auftreten einer instabilen Zone (Abrisspunkt) bei bereits niedrigeren Druck.
- Die Leistungsaufnahme des Ventilatormotors vermindert werden.
- Das Geräuschniveau insgesamt minimiert werden.

Außerdem ist die Sicherstellung eines korrekten Lufteintritts wichtig. Dieser ist gegeben, wenn der Ventilator unter Einhaltung eines saugseitigen Mindestabstandes von ca. 1 x dem Durchmesser des Ventilators installiert wird.

Wirkung des akustischen Systems und Schutzgitter:

Die Sicherheitsabstände in Bezug auf den Berührschutz sind in der Norm EN 294 festgelegt.

Wir empfehlen den Einsatz von Schutzgittern.

Die Schutzgitter erzeugen einen Widerstand beim Durchgang des Luftstroms, welcher einen Druckverlust Δp_{sf} für den Ventilator darstellt. Dieser Druckverlust steigt mit dem Quadrat der Ventilatorleistung.

Der Stromverbrauch und der Schallpegel des Ventilators werden ebenfalls beeinflusst.

Die Schutzgitter werden als Zubehör angeboten.

Information über die Sicherheit:

Die Ziehl-Abegg Axialventilatoren sind für den Betrieb innerhalb von Systemen konzipiert und sind lediglich Bestandteile dieser Systeme.

Der Hersteller der Maschine muss die Sicherheitsbestimmungen gemäß Norm EN 294 für die Anlagen bzw. das System beachten.

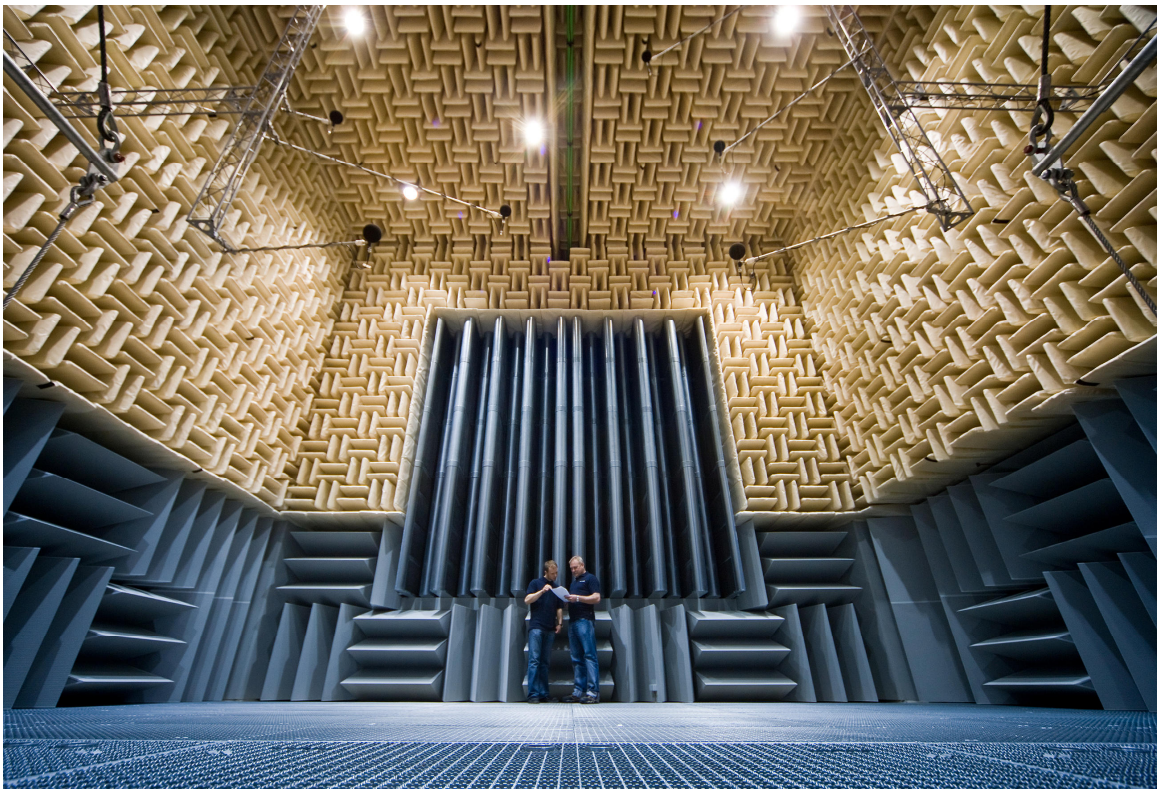

Labor "Invent", Ziehl-Abegg AG, Deutschland



La gama MAXvent 2

La gama MAXvent 2 es el resultado por un lado de una gama existente desde hace varios años en el ámbito de la ventilación de media presión y por otro lado de los esfuerzos de los equipos de ZIEHL-ABEGG FMV para dar respuesta a las necesidades específicas en términos de prestaciones en ventilación, con bajos niveles sonoros y de amplitud de gama.

Se proponen dos configuraciones de serie: carcasa circular corta y larga, según las dimensiones de la norma EUROVENT. Gracias a su comprobado diseño y a los reconocidos componentes utilizados podemos garantizar la calidad y la fiabilidad de los ventiladores de la gama MAXvent 2.

Tanto en la actualidad como en el pasado, dedicamos nuestros recursos a la mejora de nuestra gama de ventilación con la finalidad de proporcionar las máximas prestaciones y de satisfacer el conjunto de sus exigencias técnicas.

Descripción técnica

La gama de ventiladores helicoidales MAXvent 2 está dotada con una hélice con álabes de poliamida reforzada con fibras de vidrio PAG) y una carcasa de aleación de aluminio (fundido) diseñado para aplicaciones que pueden ir hasta presiones totales de 1.000 Pa según el diámetro.

En función de la pérdida de carga de su instalación, del diámetro y de la velocidad de la hélice seleccionada, el caudal disponible puede alcanzar hasta 130.000 m³/h.

Los caudales se miden según la norma ISO 5801.

Una gama amplia:

La gama MAXvent 2 está disponible en 13 diámetros: 315, 355, 400, 450, 500, 560, 630, 710, 800, 900, 1000, 1250 y 1400 mm.

Los ventiladores de la gama MAXvent 2 están dotados con motores asíncronos normalizados de rotor interior (IEC). Se trata de motores B3, IP55, clase F disponibles en 50Hz y corriente trifásica 230/400V 50 Hz hasta 2.2kW y 400/690V 50 Hz más allá, con protecciones PTC.

Según el diámetro, los motores están disponibles en 2, 4, 6 u 8 polos.

Para cada diámetro y cada velocidad de rotación, la gama tiene 5 ángulos de hélice, con un total de 175 combinaciones posibles, para responder a todas las demandas:

Ø	2 polos	4 polos	6 polos	8 polos
315	√	√		
355	√	√		
400	√	√	√	
450	√	√	√	
500	√	√	√	
560		√	√	
630		√	√	√
710		√	√	√
800		√	√	√
900		√	√	√
1000		√	√	√
1250		√	√	√
1400			√	√

En función de su necesidad, podemos proponerle una carcasa cilíndrica corta o larga o una solución sobre placa cuadrada con las dimensiones adaptadas a su necesidad, ya sea en modo funda o en aplicación de proceso industrial.

Además, bajo pedido están disponibles todas las opciones de motores normalizados.

Todos los elementos de los ventiladores de la gama MAXvent 2 están protegidos contra la corrosión y pueden ser pintados en cualquier RAL bajo pedido.

Configuraciones estándar

La gama de ventiladores MAXvent 2 está dotada de:

- Una hélice de material plástico, seleccionada específicamente para su aplicación y equilibrada según las prescripciones de la norma ISO 14694 (G = 6.3).
- Un motor IEC B3, de marca SIEMENS o similar (prensaestopas no suministrado).
- Una carcasa circular de acero.

Acondicionamiento en palet.

Dos acabados anti-corrosión:

- Revestimiento de acero galvanizado o cincado
- Revestimiento de acero galvanizado en caliente

Estos ventiladores pueden funcionar indiferentemente con eje horizontal o vertical y están disponibles en ambos sentidos de flujo de aire.

Estos ventiladores tienen un acoplamiento directo: la rueda está directamente situada en la punta del árbol del motor.

Pueden ser utilizados en todas las aplicaciones en que el aire transportado es limpio, sin polvo.

La temperatura del flujo de aire debe estar entre -30°C y +50°C para los ventiladores de la gama "Standard temperature range" y -30°C y +60°C para los ventiladores de la gama "Increased Temperature Range".

Accesorios

Variadores de velocidad, patas de montaje, tacos antivibración, virolas de entrada de aire, contrabridas, virolas elásticas, rejillas de protección (lado hélice o lado motor).

Configuraciones especiales

La compañía Ziehl-Abegg FMV puede suministrar configuraciones a medida que responden a las necesidades de sus clientes, como:

- Fabricación con placa cuadrada (todos los diámetros), adaptada al entorno del cliente.
- Fabricación de acero inoxidable (304 ou 316L) o pasivado con pintura en polvo de poliéster.
- Hélice con pala de aluminio o de polipropileno con aditivos de fibra de vidrio (PPG)
- Motor
 - EFF1
 - 2 velocidades (bobinas separadas o Dahlander)
 - 60Hz
 - Terminancias PTO
 - Utilización en baja o alta temperatura
 - Caja de bornes desplazada hacia la carcasa
 - Todas las opciones de los motores IEC
 -

Estudiamos todas las posibilidades de nuestra gama estándar.

La gama MAXvent 2



Pie

- 1 Ventilador
- 2 Caudal
- 3 Presión estática
- 4 Ángulo de inclinación
- 5 Frecuencia
- 6 Tamaño motor
- 7 Voltaje
- 8 Corriente
- 9 Potencia
- 10 Velocidad asignada
- 11 Presión acústica @ 3m
- 12 Fabricación ventilador
- 13 Nivel relativo de presión sonora del espectro
- 14 Accesorios
- 15 Temperatura

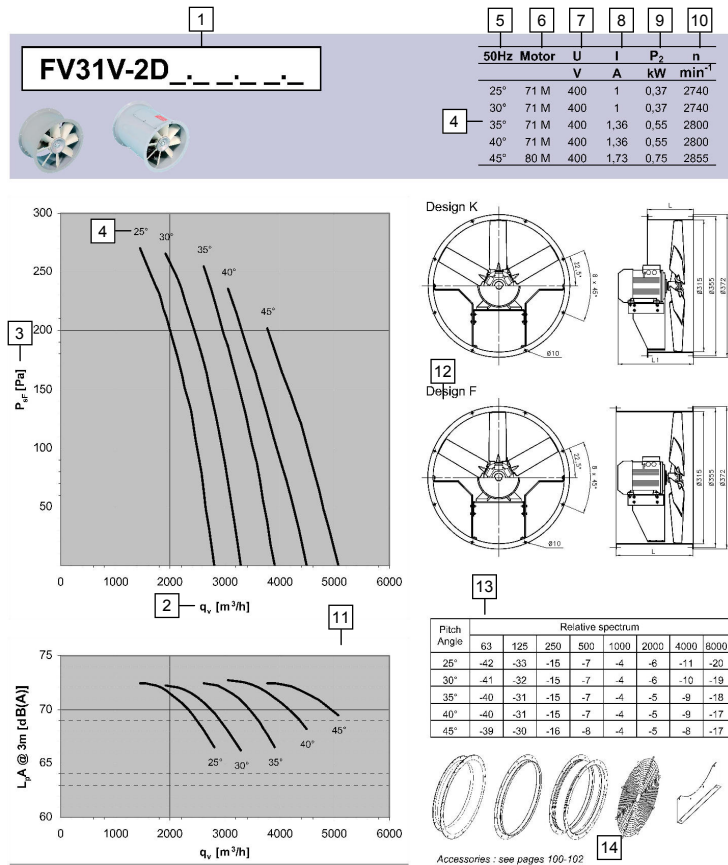

Standard Temperature Range : -30°C / +50°C

Designación

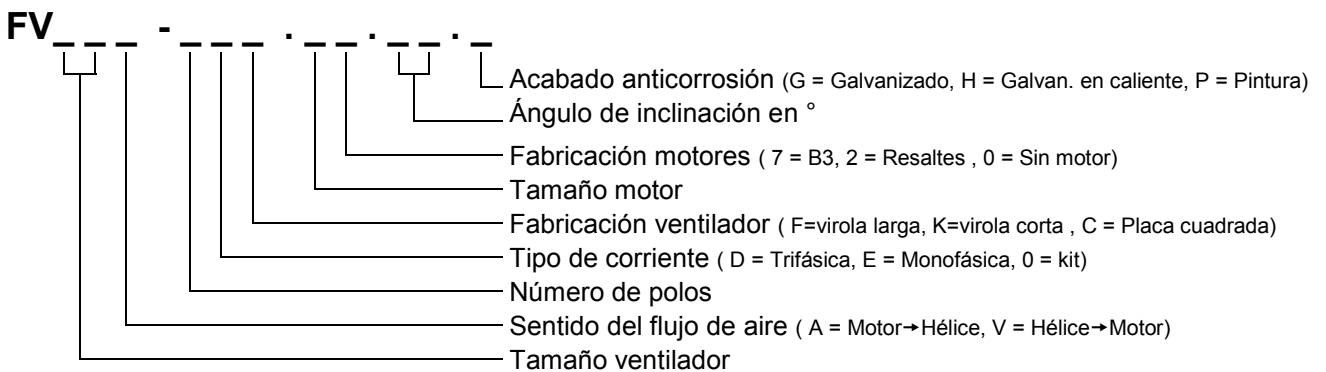

La gama MAXvent 2



Mediciones de caudal:

Las curvas características del ventilador muestran el aumento de pérdida de carga Δp_{sf} en Pa, en función del caudal en m^3/h .

Las pruebas han sido realizadas según ISO 5801 y dentro de nuestros laboratorios (laboratorio "Invent" en Alemania y el laboratorio ZA-FMV en Francia).

Todo un conjunto de mediciones realizadas en nuestros laboratorios nos han permitido elaborar las curvas presentadas abajo.

Las mediciones han sido realizadas en tipo A y en tipo D y los resultados muestran que las variaciones entre ambas mediciones están dentro de la gama de las tolerancias.

Algunas pruebas han sido corroboradas por el CETIAT (laboratorio francés homologado).

El ventilador está instalado en un cajón de mediciones con entrada y salida libres.

Las mediciones han sido realizadas sin rejilla de protección.

Mediciones acústicas:

Las pruebas han sido realizadas según ISO 13347 e ISO 5136 para la acústica.

Las potencias acústicas ponderadas A en L_w se calculan a partir de niveles de presión acústica en bandas de octava medidas en la aspiración del ventilador.

Las presiones de nivel acústico se miden según el método de la superficie envolvente en 9 puntos, sobre una superficie hemisférica descrita en la norma ISO 13347-3.

La ponderación A tiene en cuenta la sensibilidad del oído humano a determinadas frecuencias con una correlación en banda de octava.

Determinación del nivel de potencia acústica de un ventilador a partir del nivel de presión acústica a 3 metros:

$$L_w = L_p (@ 3m) + 10 \cdot \text{Log} (2 \cdot \pi \cdot R^2) + 20 \cdot \text{Log} (3), \quad \text{donde } R = 1$$

Determinación del nivel de potencia acústica en función del espectro en gama de octavas:

$$L_w = 10 \cdot \text{Log} \left(\sum 10^{(0.1 \cdot L_{wi})} \right), \quad \text{donde } i = \text{bandas de octavas}$$

Cuidado: Algunos estándares nacionales de mediciones (Ej. BS 848) utilizan mediciones realizadas a distancias diferentes de las normas vigentes y esto puede suponer disminuciones significativas en función del tamaño del ventilador.

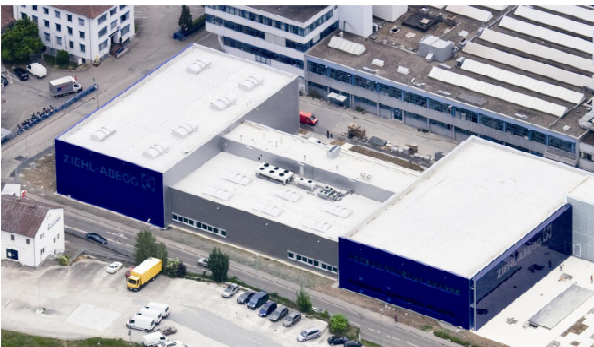

Laboratorio "Invent", Ziehl-Abegg AG, Alemania

La gama MAXvent 2



Tolerancias generales:

- En los caudales: $\pm 5\%$ del caudal nominal
- En los niveles de presión y de potencia sonora: $\pm 3\text{dB}$
- Por banda de octava: $\pm 5\text{dB}$

Embocaduras y sus efectos en la aerólucica y la acústica:

Las pruebas han sido realizadas con una mariposa de entrada optimizada, que permite:

- Minimizar los efectos de integración, responsables de la disminución del caudal y de la aparición de un punto de bombeo a una presión más baja de lo previsto.
- Optimizar el consumo del motoventilador.
- Minimizar el ruido de integración y de bombeo.

Además, es importante asegurar una entrada de aire correcta cuando el ventilador está instalado, dejando una distancia mínima igual a su diámetro.

Efecto en el sistema acústico y rejilla de protección:

Las distancias de seguridad para prevenir el acceso a las zonas peligrosas se especifican en la norma EN 294.

Con esta finalidad, aconsejamos utilizar rejillas de protección. Las rejillas ocasionan una resistencia al paso del flujo de aire que supone aumento en la pérdida de carga Δp_{sf} para el ventilador; esta pérdida de presión aumenta con el cuadrado del caudal del ventilador.

El consumo eléctrico y el nivel acústico del ventilador también se encuentran modificados.

Las rejillas de protección están disponibles como accesorios.

Información sobre la seguridad:

Los ventiladores axiales Ziehl-Abegg están diseñados para funcionar en el interior de sistemas y sólo son componentes de estos sistemas.

El fabricante de la máquina debe cumplir las especificaciones de seguridad de los equipos o del sistema, como lo especifica la norma EN 294.

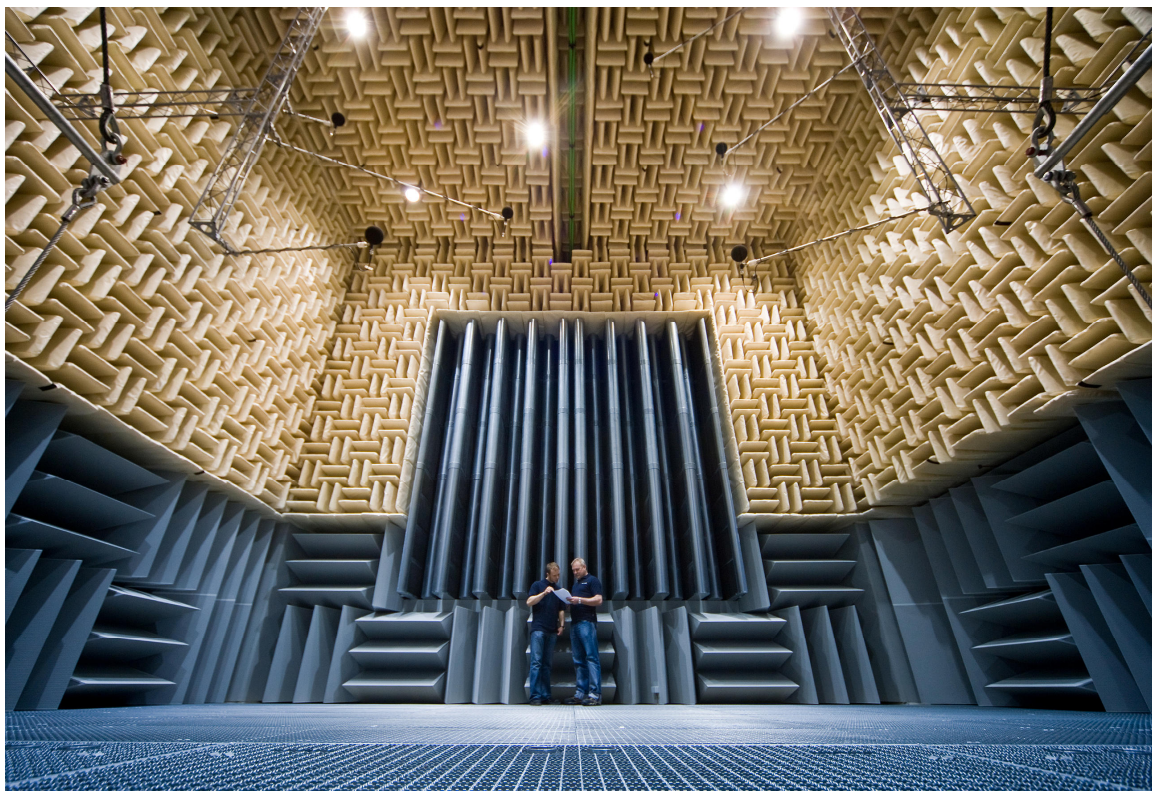

Laboratorio "Invent", Ziehl-Abegg AG, Alemania

La gamma MAXvent 2



La gamma MAXvent 2 ha origine da una parte da una gamma esistente da molti anni nel campo della ventilazione a media pressione e dall'altra parte dagli sforzi dell'equipe ZIEHL-ABEGG FMV per rispondere ai vostri bisogni specifici in termini di prestazioni aerauliche, di basso livello sonoro, di vantaggi tecnici e di ampiezza di gamma.

Sono proposte due configurazioni in standard: cassa d'alloggiamento corta o lunga secondo le dimensioni della norma EUROVENT. Grazie al suo design collaudato ed ai componenti di marca utilizzati, possiamo garantire la qualità e l'affidabilità dei ventilatori della gamma MAXvent 2.

Dedichiamo oggi come ieri tutte le nostre risorse al miglioramento della gamma dei ventilatori allo scopo di fornirvi il massimo delle prestazioni e di soddisfare l'insieme delle vostre esigenze tecniche.

Descrizione tecnica

La gamma di ventilatori elicoidali MAXvent 2 è equipaggiata di una girante con pale in poliammide rinforzato in fibra di vetro (PAG) e un mozzo in lega d'alluminio pressofuso progettato per applicazioni che possono raggiungere delle pressioni totali di 1000 Pa a seconda del diametro.

In funzione della perdita di carico della vostra installazione, del diametro e della velocità della girante scelta la portata disponibile può raggiungere i 130.000 m³/h.

Le portate sono misurate secondo ISO 5801.

Una vasta gamma:

La gamma MAXvent 2 è disponibile in 13 diametri: 315, 355, 400, 450, 500, 560, 630, 710, 800, 900, 1000, 1250 e 1400 mm.

I ventilatori della gamma MAXvent 2 sono equipaggiati con motori asincroni a rotore interno normalizzati (IEC). Si tratta di motori a staffe B3, IP55, classe F disponibili in trifase 230/400V 50Hz fino a 2,2kW e 400/690V 50Hz ed oltre con protezione tramite termistori PTC.

A seconda del diametro, i motori sono disponibili in 2 poli, 4 poli, 6 poli o 8 poli.

Per ogni diametro ed ogni velocità di rotazione la gamma comporta 5 angoli d'inclinazione pala, in totale 175 combinazioni possibili al fine di rispondere a tutte le richieste:

Ø	2 poli	4 poli	6 poli	8 poli
315	√	√		
355	√	√		
400	√	√	√	
450	√	√	√	
500	√	√	√	
560		√	√	
630		√	√	√
710		√	√	√
800		√	√	√
900		√	√	√
1000		√	√	√
1250		√	√	√
1400			√	√

In funzione delle vostre necessità, possiamo proporvi soluzioni con cassa d'alloggiamento corta o lunga o una soluzione su piastra quadrata, alle dimensioni adatte alle vostre richieste, sia per applicazioni in sistemi canalizzati che per impieghi in processi industriali.

Inoltre sono disponibili su richiesta tutte le opzioni dei motori normalizzati.

Tutti i componenti dei ventilatori della gamma MAXvent 2 sono protetti contro la corrosione e possono essere verniciati su richiesta.

Configurazioni standard

La gamma di ventilatori MAXvent 2 è equipaggiata:

- da una girante in materiale composito selezionata da noi per la vostra applicazione ed equilibrata secondo le prescrizioni della norma ISO 14694 (G = 6.3)
- da un motore IEC a staffe B3 di marca SIEMENS o simile (pressacavo non in dotazione)
- da una cassa d'alloggiamento in acciaio.

Imballo su pallet.

Due finiture anticorrosione:

- Cassa in acciaio galvanizzato o zincato a freddo
- Cassa in acciaio galvanizzato a caldo

Questi ventilatori possono funzionare indifferentemente con l'asse orizzontale o verticale e sono disponibili per entrambi i sensi del flusso d'aria.

Questi ventilatori sono in accoppiamento diretto: la girante è posizionata direttamente all'estremità dell'albero motore.

Nella configurazione Standard, possono essere utilizzati per tutte le applicazioni in cui l'aria veicolata è pulita, non polverosa.

La temperatura del flusso d'aria deve essere compresa tra – 30°C e +50°C per i ventilatori della sezione «Standard temperature range» e -30°C e +60°C per i ventilatori della sezione «Increased Temperature Range».

Accessori

Variatori di velocità, piedi di montaggio, giunti anti-vibranti, boccagli d'aspirazione, contro-flange, giunti elastici, griglie di protezione (lato girante o lato motore).

Configurazioni speciali

Ziehl-Abegg FMV può offrire delle esecuzioni speciali che rispondono al meglio alle necessità del cliente come:

- Costruzione con pannello quadrato (qualsiasi diametro) adatto all'ambiente del cliente
- Costruzione in acciaio inossidabile (304 o 316L) o rifiniture in vernice polvere poliesteri
- Girante con pale in alluminio o polipropilene caricato con fibra di vetro (PPG)
- Motore
 - EFF1
 - 2 velocità (avvolgimento separato o Dahlander)
 - 60Hz
 - Termistori PTO
 - Uso bassa o alta temperatura
 - Morsettiera sulla cassa d'alloggiamento
 - Tutte le opzioni dei motori IEC
 -

Prenderemo in esame qualsiasi richiesta diversa dai nostri prodotti standard....

Consultateci!

La gamma MAXvent 2



Legende

- 1 Ventilatore
- 2 Portata d'aria
- 3 Pressione statica
- 4 Angolo inclinazione della pala
- 5 Frequenze
- 6 Grandezza motore
- 7 Tensioni
- 8 Corrente
- 9 Potenza nominale
- 10 Velocità nominale
- 11 pressione sonora @ 3m
- 12 Costruzione del ventilatore
- 13 Relativo livello di potenza sonora spettro
- 14 Accessori
- 15 Temperatura

FV31V-2D

50Hz	Motor	U	I	P ₂	n
	V	A	kW	min ⁻¹	
25°	71 M	400	1	0,37	2740
30°	71 M	400	1	0,37	2740
35°	71 M	400	1,36	0,55	2800
40°	71 M	400	1,36	0,55	2800
45°	80 M	400	1,73	0,75	2855

Pitch Angle	Relative spectrum							
	63	125	250	500	1000	2000	4000	8000
25°	-42	-33	-15	-7	-4	-6	-11	-20
30°	-41	-32	-15	-7	-4	-6	-10	-19
35°	-40	-31	-15	-7	-4	-5	-9	-18
40°	-40	-31	-15	-7	-4	-5	-9	-17
45°	-39	-30	-16	-8	-4	-5	-8	-17

Accessories : see pages 100-102

Standard Temperature Range : -30°C / +50°C

Designazione

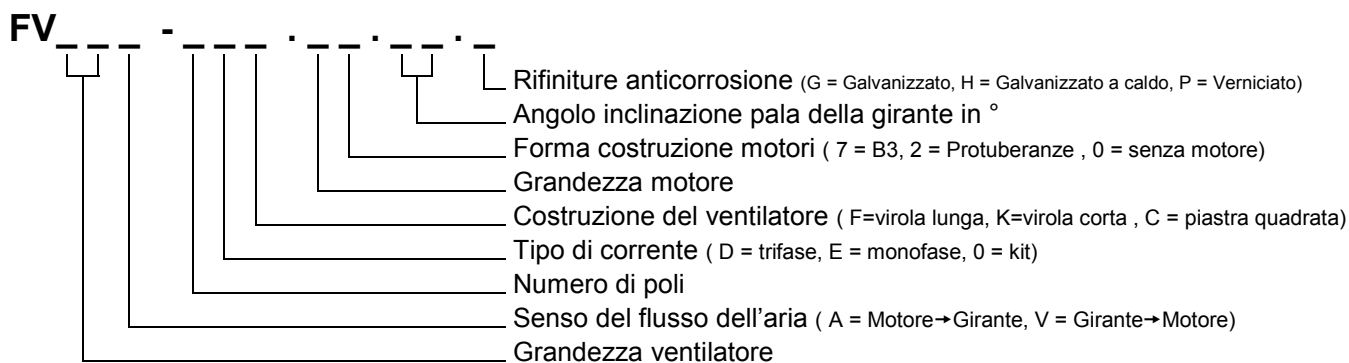

La gamma MAXvent 2



Misure aerauliche:

Le curve caratteristiche del ventilatore indicano l'aumento di pressione Δp_{sf} in pascal in funzione della portata in m³/ora.

I test sono stati effettuati secondo ISO5801 per l'aeraulica e nei nostri laboratori (laboratorio "Invent" in Germania e laboratorio ZA-FMV in Francia).

Tutto un insieme di misure effettuate nei nostri laboratori ci hanno permesso di tracciare le curve presentate qui di seguito.

Le misure sono state effettuate in tipo A e in tipo D e i risultati indicano che le variazioni tra le 2 misure sono nei limiti di tolleranza delle stesse.

Alcuni test sono stati convalidati dal CETIAT (laboratorio francese approvato).

Il ventilatore è installato in un cassone per misure con ingresso e uscita liberi.

Le misure sono state effettuate senza griglia di protezione.

Misure acustiche:

I test sono stati effettuati secondo ISO13347 e ISO5136 per l'acustica.

Le potenze acustiche ponderate A in L_w sono calcolate partendo dai livelli di pressione acustica in bande di ottava misurate durante l'aspirazione del ventilatore.

I livelli di pressione sonora sono misurati secondo il metodo della superficie avvolgente in 9 punti sulla superficie semisferica descritta nella norma ISO 13347-3.

La ponderazione A tiene conto della sensibilità dell'orecchio umano a certe frequenze tramite una correzione in banda d'ottava.

Determinazione del livello di potenza acustica di un ventilatore partendo dal livello di pressione acustica a 3 metri:

$$L_w = L_p (@ 3m) + 10 \cdot \text{Log} (2 \cdot \pi \cdot R^2) + 20 \cdot \text{Log} (3), \quad \text{con } R = 1$$

Determinazione del livello di potenza acustica in funzione dello spettro in gamme di ottave:

$$L_w = 10 \cdot \text{Log} \left(\sum 10^{(0.1 \cdot L_{wi})} \right), \quad \text{con } i = \text{banda di ottave}$$

Attenzione: alcuni vecchi standard di misure nazionali (es. BS 848) si affidano a misure effettuate a distanze diverse dalle norme vigenti; questo può dar luogo a sottovalutazioni significative a seconda delle dimensioni del ventilatore.

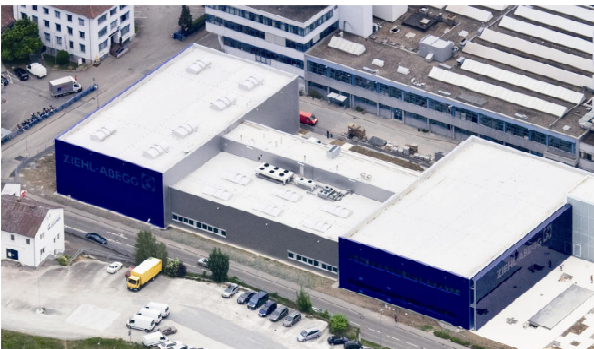

Laboratorio "Invent", Ziehl-Abegg AG, Germania

La gamma MAXvent 2



Tolleranze generali:

- Sulle portate: $\pm 5\%$ della portata nominale
- Sui livelli di pressione e di potenza acustica: $\pm 3\text{dB}$
- Per banda di ottava: $\pm 5\text{dB}$

Bocchigli d'ingresso d'aria ed effetti sull'aeraulica e l'acustica:

Le prove sono state effettuate con un bocchiglio d'ingresso d'aria ottimizzato, che permette:

- di ridurre gli effetti d'integrazione responsabili della riduzione della portata e dell'apparizione di un punto di pompaggio a una pressione inferiore a quella prevista
- di ottimizzare il consumo del motoventilatore
- di ridurre il rumore d'integrazione e di pompaggio

D'altronde è importante assicurare un buon ingresso d'aria quando il ventilatore è installato, pur rispettando una minima distanza di circa 1 volta il diametro del ventilatore.

Effetto sistema acustico e griglia di protezione:

Le distanze di sicurezza per evitare l'accessibilità alle zone pericolose sono specificate nella norma EN 294.

A tale scopo raccomandiamo l'uso delle griglie di protezione. Le griglie provocano una resistenza al passaggio del flusso d'aria, che rappresenta una perdita di pressione Δp_{sf} per il ventilatore; tale perdita di pressione aumenta con il quadrato della portata del ventilatore.

Il consumo elettrico e il livello sonoro del ventilatore sono ugualmente interessati.

Le griglie di protezione sono proposte come accessori.

Informazione sulla sicurezza:

I ventilatori assiali Ziehl-Abegg sono predisposti per funzionare all'interno dei sistemi e sono soltanto componenti degli stessi.

Il produttore della macchina deve conformarsi alle specifiche di sicurezza delle attrezzature o del sistema secondo la norma EN 294.

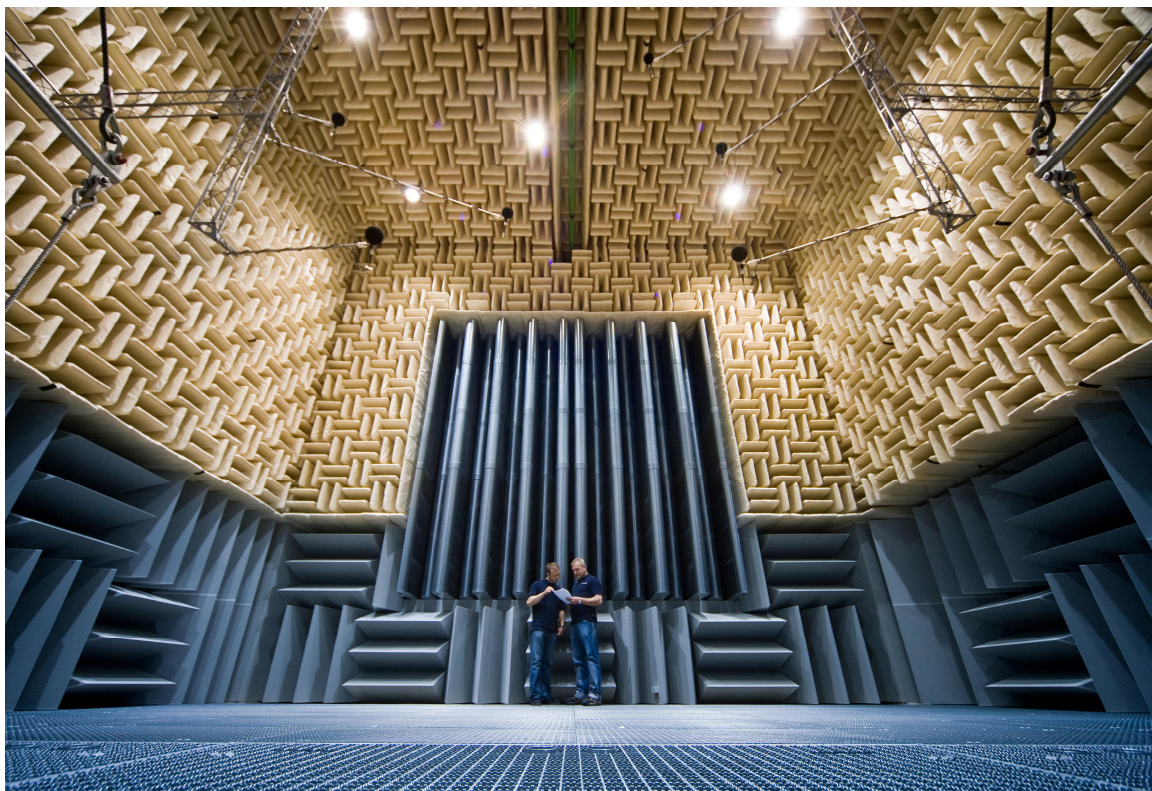

Laboratorio "Invent", Ziehl-Abegg AG, Germania

Standard Temperature Range

Working Temperature : - 30°C / + 50°C

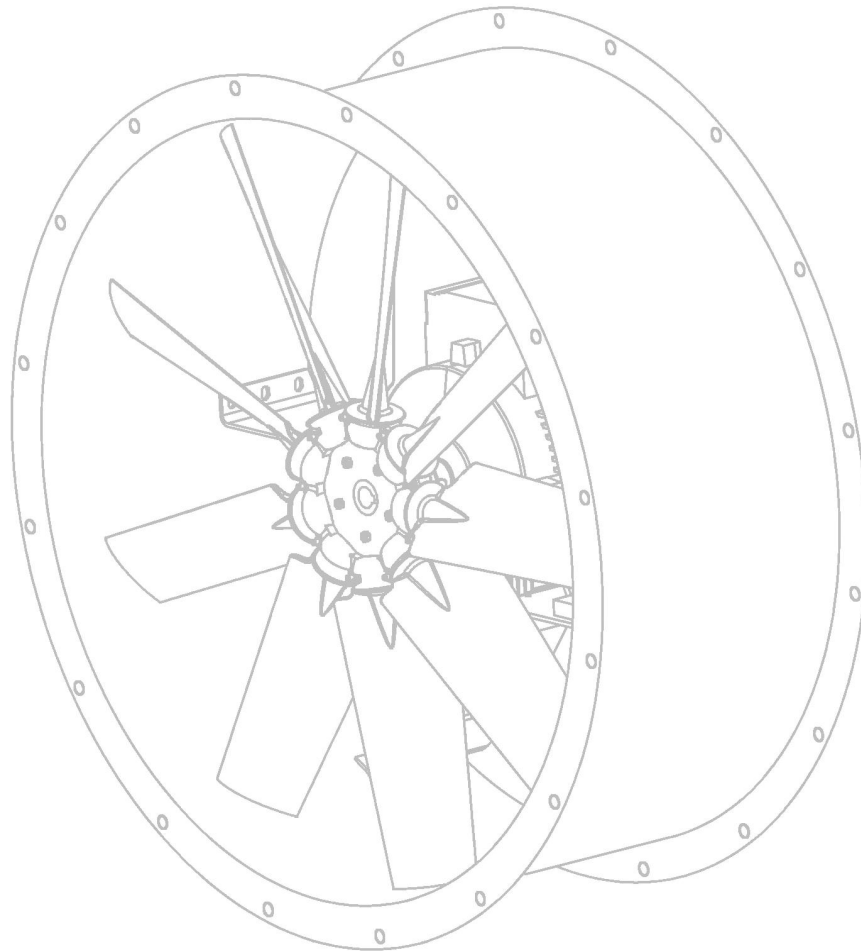

Standard Temperature Range : -30°C / +50°C

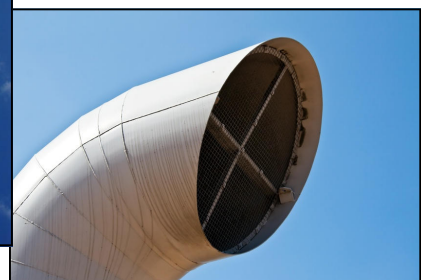
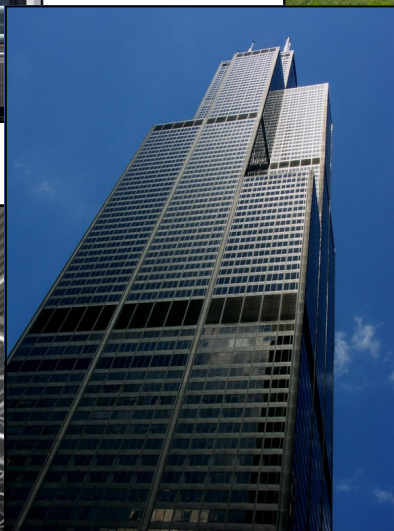
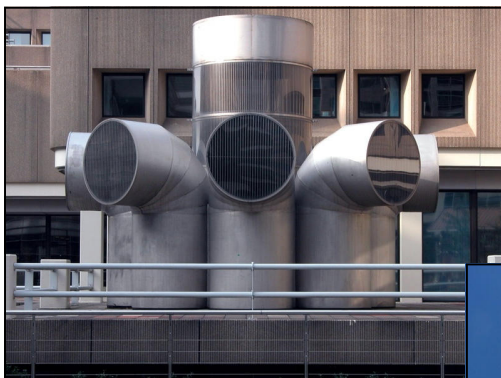

FV31V-2D

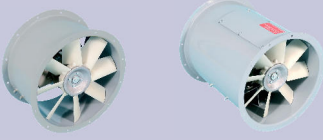

50Hz Motor	U	I	P ₂	n	
	V	A	kW	min ⁻¹	
25°	71 M	400	1	0,37	2740
30°	71 M	400	1	0,37	2740
35°	71 M	400	1,36	0,55	2800
40°	71 M	400	1,36	0,55	2800
45°	80 M	400	1,73	0,75	2855

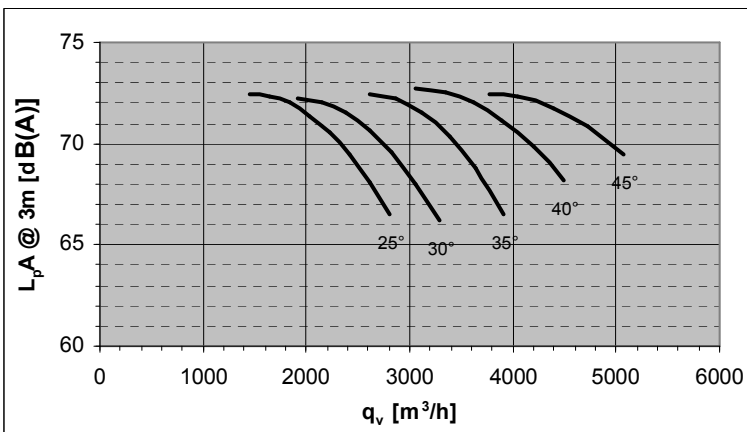
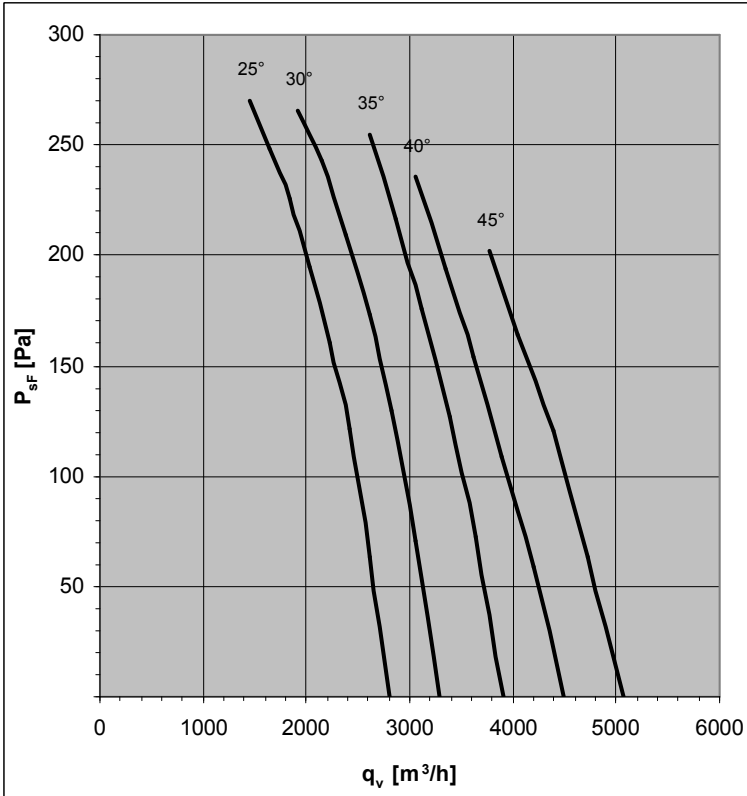

Design K

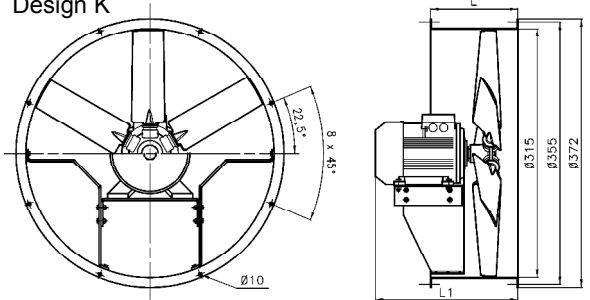

Design F

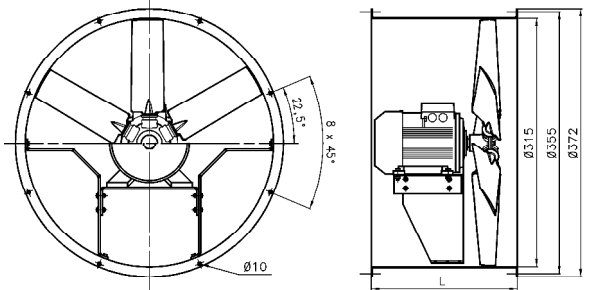

Pitch Angle	Relative spectrum							
	63	125	250	500	1000	2000	4000	8000
25°	-42	-33	-15	-7	-4	-6	-11	-20
30°	-41	-32	-15	-7	-4	-6	-10	-19
35°	-40	-31	-15	-7	-4	-5	-9	-18
40°	-40	-31	-15	-7	-4	-5	-9	-17
45°	-39	-30	-16	-8	-4	-5	-8	-17

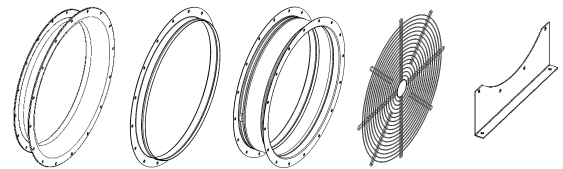

Accessories : see pages 100-102

Design	Pitch Angle	Type (G finish)	Part N°	Type (H finish)	Part N°	L1(mm)	L(mm)	Weight (kg)
K	25°	FV31V-2DK.A7.25.G	150000	FV31V-2DK.A7.25.H	150001	338	260	15
	30°	FV31V-2DK.A7.30.G	150004	FV31V-2DK.A7.30.H	150005	338	260	15
	35°	FV31V-2DK.A7.35.G	150008	FV31V-2DK.A7.35.H	150009	338	260	16
	40°	FV31V-2DK.A7.40.G	150012	FV31V-2DK.A7.40.H	150013	338	260	16
	45°	FV31V-2DK.B7.45.G	150016	FV31V-2DK.B7.45.H	150017	339	260	19
F	25°	FV31V-2DF.A7.25.G	150002	FV31V-2DF.A7.25.H	150003	---	350	17
	30°	FV31V-2DF.A7.30.G	150006	FV31V-2DF.A7.30.H	150007	---	350	17
	35°	FV31V-2DF.A7.35.G	150010	FV31V-2DF.A7.35.H	150011	---	350	18
	40°	FV31V-2DF.A7.40.G	150014	FV31V-2DF.A7.40.H	150015	---	350	18
	45°	FV31V-2DF.B7.45.G	150018	FV31V-2DF.B7.45.H	150019	---	350	21

FV31V-4D



50Hz Motor	U	I	P ₂	n	
	V	A	kW	min ⁻¹	
25°	56 M	400	0,2	0,06	1350
30°	56 M	400	0,2	0,06	1350
35°	56 M	400	0,2	0,06	1350
40°	56 M	400	0,2	0,06	1350
45°	56 M	400	0,29	0,09	1350

Standard Temperature Range : -30°C / +50°C

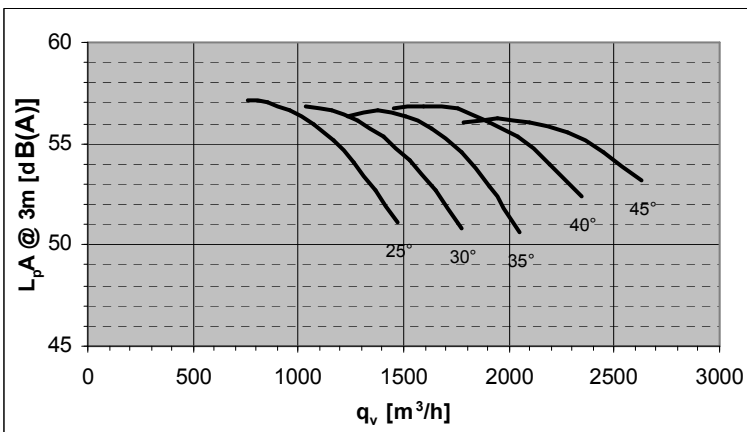
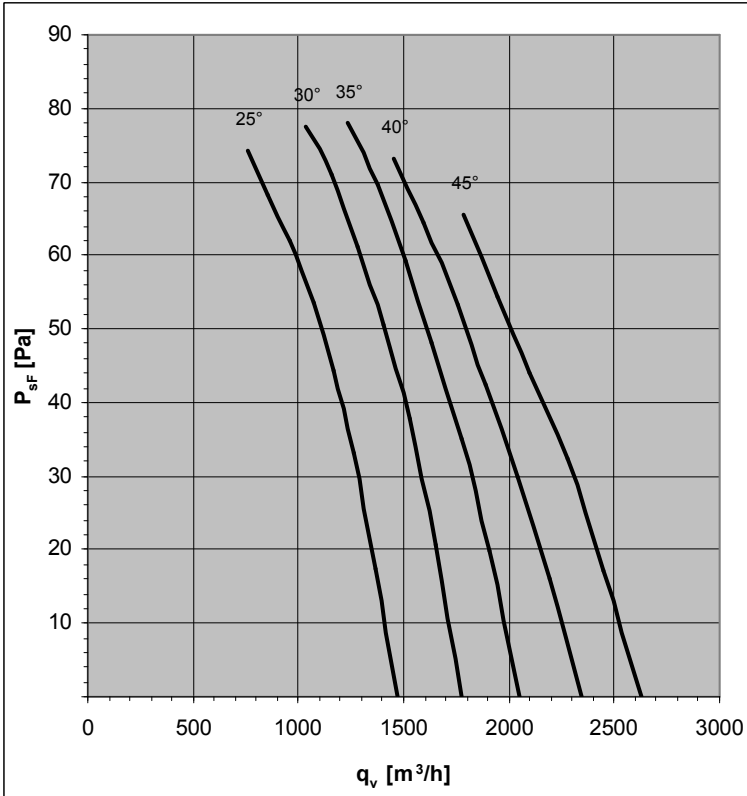

Design K

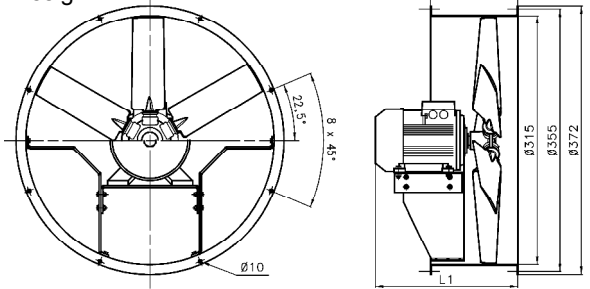

Design F

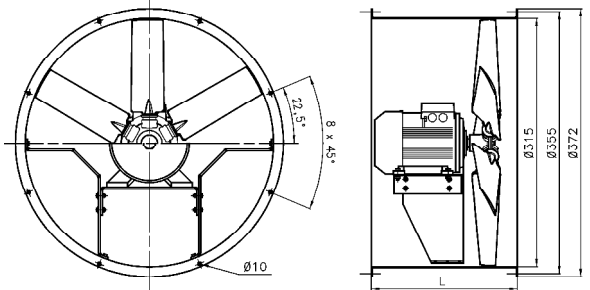

Pitch Angle	Relative spectrum							
	63	125	250	500	1000	2000	4000	8000
25°	-34	-27	-12	-6	-3	-5	-9	-17
30°	-33	-26	-12	-6	-3	-5	-8	-16
35°	-32	-25	-12	-6	-3	-4	-8	-15
40°	-32	-25	-12	-6	-3	-4	-7	-14
45°	-32	-25	-13	-6	-3	-4	-7	-14

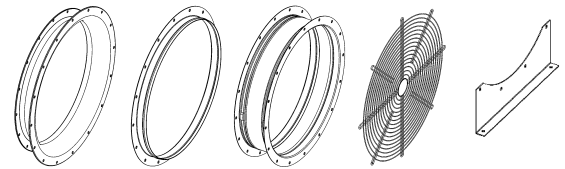

Accessories : see pages 100-102

Design	Pitch Angle	Type (G finish)	Part N°	Type (H finish)	Part N°	L1(mm)	L(mm)	Weight (kg)
K	25°	FV31V-4DK.87.25.G	150020	FV31V-4DK.87.25.H	150021	270	260	12
	30°	FV31V-4DK.87.30.G	150024	FV31V-4DK.87.30.H	150025	270	260	12
	35°	FV31V-4DK.87.35.G	150028	FV31V-4DK.87.35.H	150029	270	260	12
	40°	FV31V-4DK.87.40.G	150032	FV31V-4DK.87.40.H	150033	270	260	12
	45°	FV31V-4DK.87.45.G	150036	FV31V-4DK.87.45.H	150037	270	260	12
F	25°	FV31V-4DF.87.25.G	150022	FV31V-4DF.87.25.H	150023	---	350	14
	30°	FV31V-4DF.87.30.G	150026	FV31V-4DF.87.30.H	150027	---	350	14
	35°	FV31V-4DF.87.35.G	150030	FV31V-4DF.87.35.H	150031	---	350	14
	40°	FV31V-4DF.87.40.G	150034	FV31V-4DF.87.40.H	150035	---	350	14
	45°	FV31V-4DF.87.45.G	150038	FV31V-4DF.87.45.H	150039	---	350	14

FV35V-2D

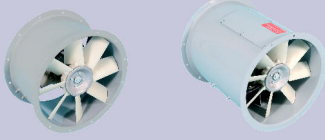

50Hz Motor	U	I	P ₂	n	
	V	A	kW	min ⁻¹	
25°	71 M	400	1,36	0,55	2800
30°	80 M	400	1,73	0,75	2855
35°	80 M	400	2,4	1,1	2845
40°	80 M	400	2,4	1,1	2845
45°	90 S	400	3,25	1,5	2860

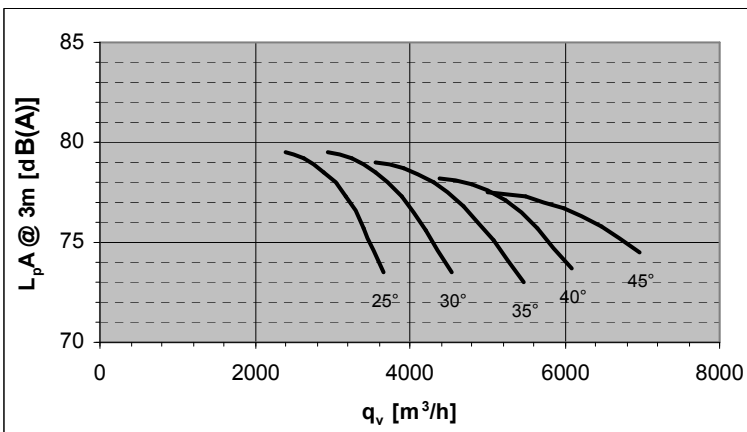
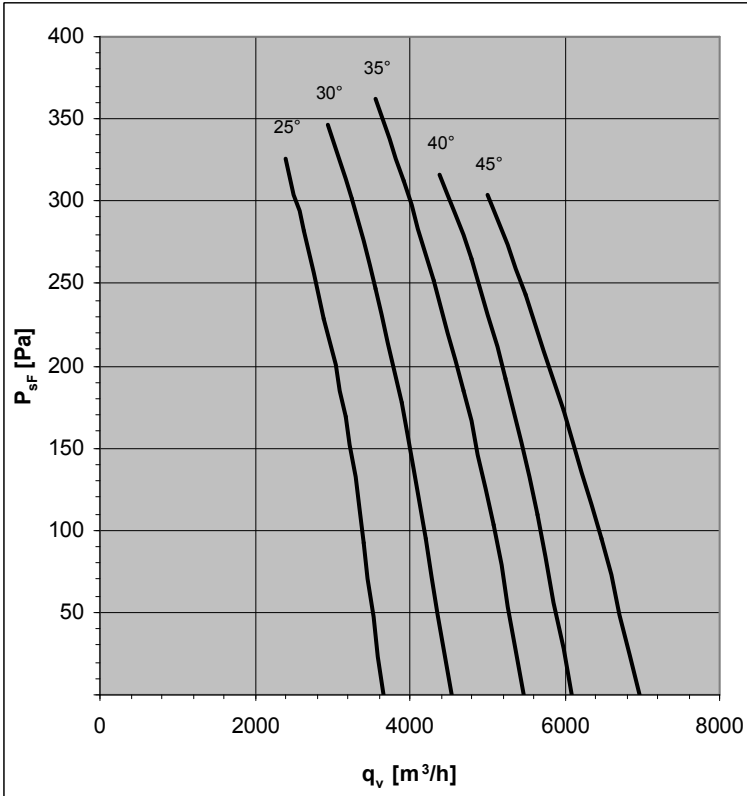

Design K

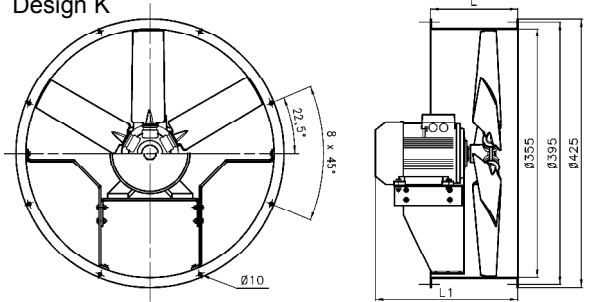

Design F

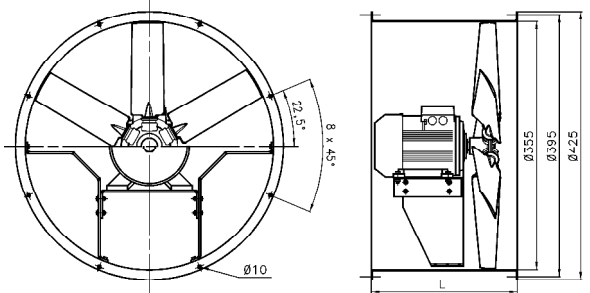

Pitch Angle	Relative spectrum							
	63	125	250	500	1000	2000	4000	8000
25°	-46	-36	-16	-8	-4	-6	-12	-22
30°	-44	-35	-16	-8	-4	-6	-11	-21
35°	-43	-34	-16	-8	-4	-6	-10	-20
40°	-42	-33	-16	-8	-4	-6	-10	-19
45°	-41	-32	-17	-8	-4	-5	-9	-18

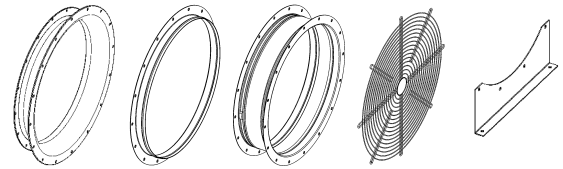

Accessories : see pages 100-102

Design	Pitch Angle	Type (G finish)	Part N°	Type (H finish)	Part N°	L1(mm)	L(mm)	Weight (kg)
K	25°	FV35V-2DK.A7.25.G	150052	FV35V-2DK.A7.25.H	150053	338	260	18
	30°	FV35V-2DK.B7.30.G	150056	FV35V-2DK.B7.30.H	150057	339	260	21
	35°	FV35V-2DK.B7.35.G	150060	FV35V-2DK.B7.35.H	150061	339	260	23
	40°	FV35V-2DK.B7.40.G	150064	FV35V-2DK.B7.40.H	150065	339	260	23
	45°	FV35V-2DK.C7.45.G	150068	FV35V-2DK.C7.45.H	150069	392	260	25
F	25°	FV35V-2DF.A7.25.G	150054	FV35V-2DF.A7.25.H	150055	---	400	21
	30°	FV35V-2DF.B7.30.G	150058	FV35V-2DF.B7.30.H	150059	---	400	24
	35°	FV35V-2DF.B7.35.G	150062	FV35V-2DF.B7.35.H	150063	---	400	26
	40°	FV35V-2DF.B7.40.G	150066	FV35V-2DF.B7.40.H	150067	---	400	26
	45°	FV35V-2DF.C7.45.G	150070	FV35V-2DF.C7.45.H	150071	---	400	28

FV35V-4D

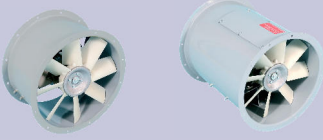

50Hz Motor	U	I	P ₂	n	
	V	A	kW	min ⁻¹	
25°	56 M	400	0,2	0,06	1350
30°	56 M	400	0,29	0,09	1350
35°	63 M	400	0,42	0,12	1350
40°	63 M	400	0,42	0,12	1350
45°	63 M	400	0,58	0,18	1350

Standard Temperature Range : -30°C / +50°C

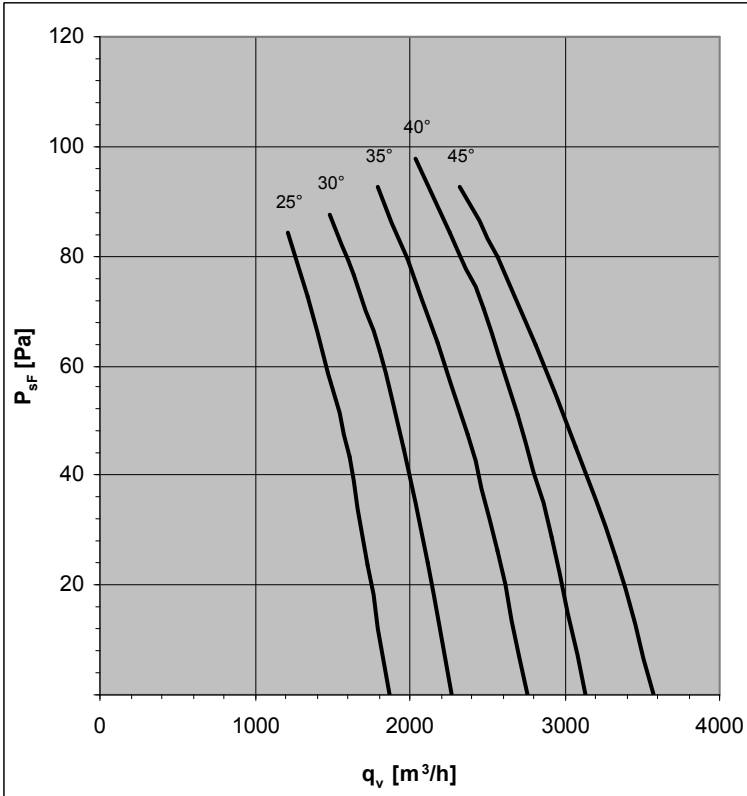

Design K

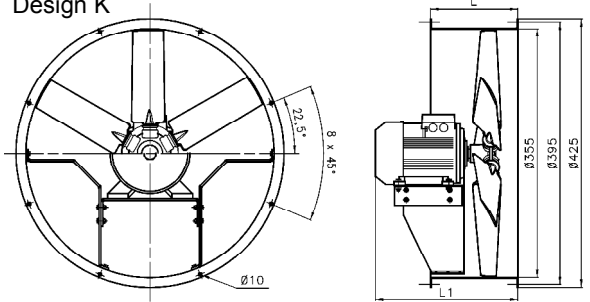

Design F

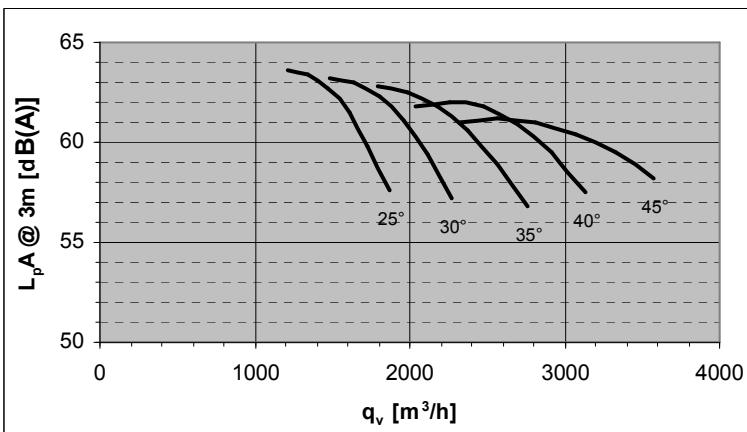
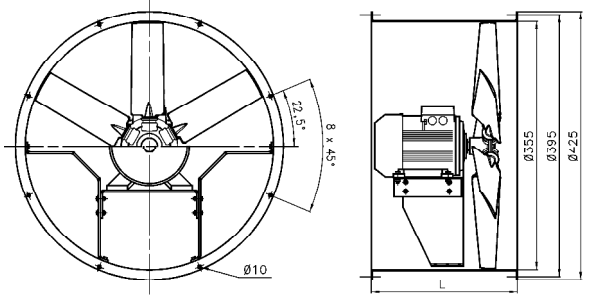

Pitch Angle	Relative spectrum							
	63	125	250	500	1000	2000	4000	8000
25°	-38	-30	-13	-6	-4	-5	-10	-18
30°	-36	-29	-13	-6	-3	-5	-9	-17
35°	-35	-28	-13	-6	-3	-5	-8	-16
40°	-35	-27	-13	-7	-3	-5	-8	-15
45°	-34	-26	-14	-7	-3	-4	-7	-14

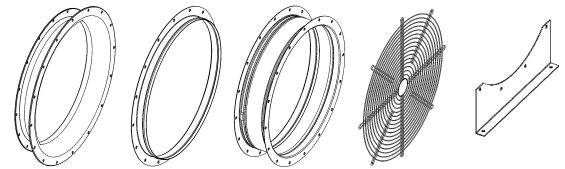

Accessories : see pages 100-102

Design	Pitch Angle	Type (G finish)	Part N°	Type (H finish)	Part N°	L1(mm)	L(mm)	Weight (kg)
K	25°	FV35V-4DK.87.25.G	150072	FV35V-4DK.87.25.H	150073	270	260	14
	30°	FV35V-4DK.87.30.G	150076	FV35V-4DK.87.30.H	150077	270	260	14
	35°	FV35V-4DK.97.35.G	150080	FV35V-4DK.97.35.H	150081	295	260	14
	40°	FV35V-4DK.97.40.G	150084	FV35V-4DK.97.40.H	150085	295	260	14
	45°	FV35V-4DK.97.45.G	150088	FV35V-4DK.97.45.H	150089	295	260	15
F	25°	FV35V-4DF.87.25.G	150074	FV35V-4DF.87.25.H	150075	---	400	17
	30°	FV35V-4DF.87.30.G	150078	FV35V-4DF.87.30.H	150079	---	400	17
	35°	FV35V-4DF.97.35.G	150082	FV35V-4DF.97.35.H	150083	---	400	17
	40°	FV35V-4DF.97.40.G	150086	FV35V-4DF.97.40.H	150087	---	400	17
	45°	FV35V-4DF.97.45.G	150090	FV35V-4DF.97.45.H	150091	---	400	18

FV40V-2D

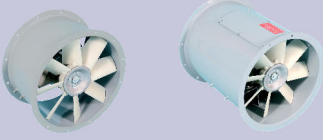

50Hz Motor	U	I	P ₂	n	
	V	A	kW	min ⁻¹	
25°	80 M	400	2,4	1,1	2845
30°	80 M	400	2,4	1,1	2845
35°	90 S	400	3,25	1,5	2860
40°	90 L	400	4,55	2,2	2880
45°	100 L	400	6	3	2835

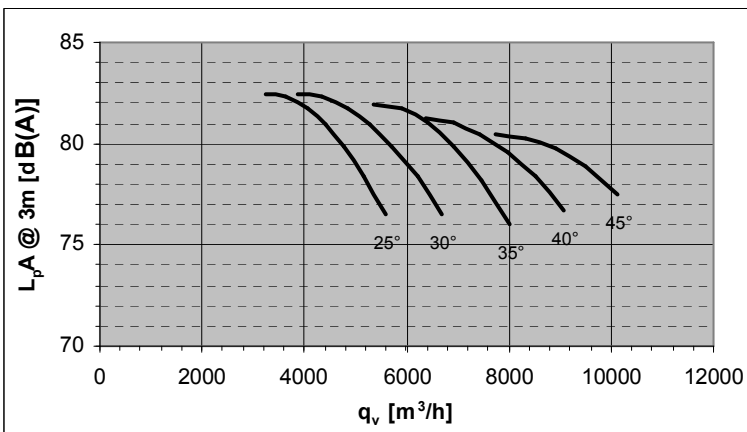
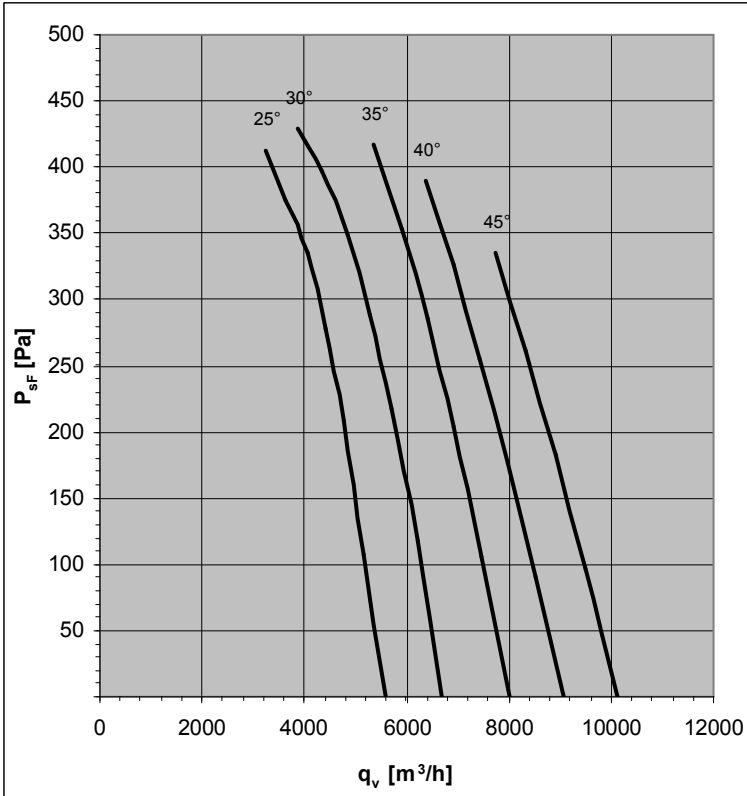

Design K

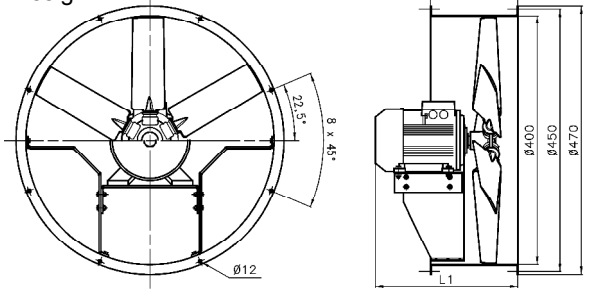

Design F

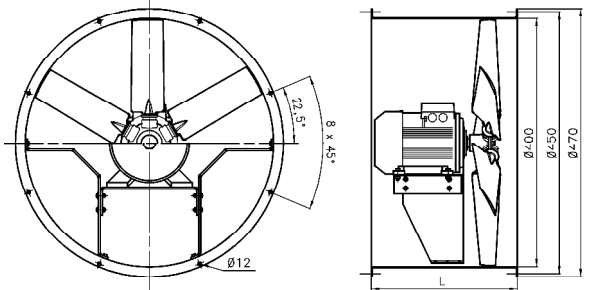

Pitch Angle	Relative spectrum							
	63	125	250	500	1000	2000	4000	8000
25°	-47	-37	-16	-8	-4	-6	-12	-23
30°	-46	-36	-16	-8	-4	-6	-11	-22
35°	-44	-35	-17	-8	-4	-6	-10	-20
40°	-44	-34	-17	-8	-4	-6	-10	-19
45°	-43	-33	-17	-8	-4	-6	-9	-18

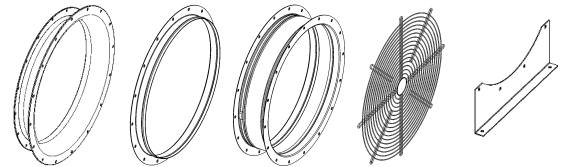

Accessories : see pages 100-102

Design	Pitch Angle	Type (G finish)	Part N°	Type (H finish)	Part N°	L1(mm)	L(mm)	Weight (kg)
K	25°	FV40V-2DK.B7.25.G	150112	FV40V-2DK.B7.25.H	150113	339	260	24
	30°	FV40V-2DK.B7.30.G	150116	FV40V-2DK.B7.30.H	150117	339	260	24
	35°	FV40V-2DK.C7.35.G	150120	FV40V-2DK.C7.35.H	150121	392	260	26
	40°	FV40V-2DK.D7.40.G	150124	FV40V-2DK.D7.40.H	150125	392	260	29
	45°	FV40V-2DK.E7.45.G	150128	FV40V-2DK.E7.45.H	150129	460	260	33
F	25°	FV40V-2DF.B7.25.G	150114	FV40V-2DF.B7.25.H	150115	---	470	29
	30°	FV40V-2DF.B7.30.G	150118	FV40V-2DF.B7.30.H	150119	---	470	29
	35°	FV40V-2DF.C7.35.G	150122	FV40V-2DF.C7.35.H	150123	---	470	31
	40°	FV40V-2DF.D7.40.G	150126	FV40V-2DF.D7.40.H	150127	---	470	33
	45°	FV40V-2DF.E7.45.G	150130	FV40V-2DF.E7.45.H	150131	---	470	38

FV40V-4D

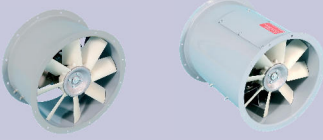

50Hz Motor	U	I	P ₂	n	
	V	A	kW	min ⁻¹	
25°	56 M	400	0,29	0,09	1350
30°	63 M	400	0,42	0,12	1350
35°	63 M	400	0,58	0,18	1350
40°	71 M	400	0,77	0,25	1350
45°	71 M	400	0,77	0,25	1350

Standard Temperature Range : -30°C / +50°C

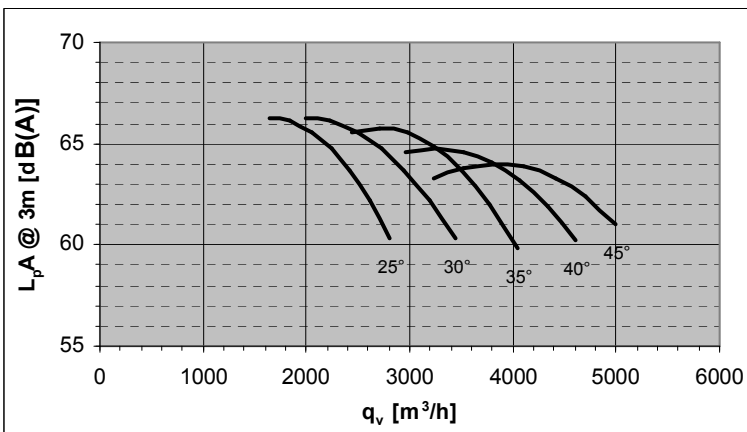
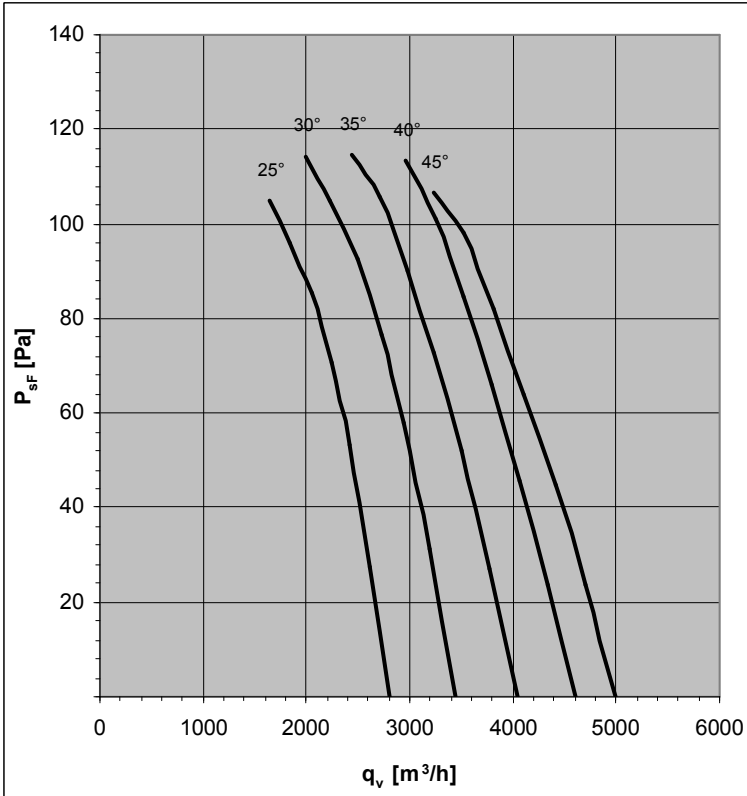

Design K

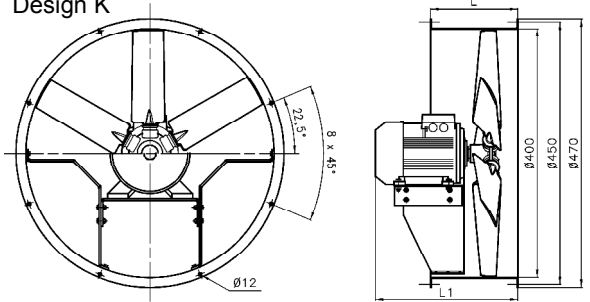

Design F

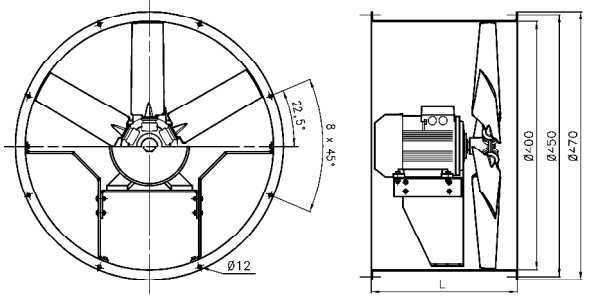

Pitch Angle	Relative spectrum							
	63	125	250	500	1000	2000	4000	8000
25°	-39	-31	-13	-7	-4	-5	-10	-19
30°	-38	-30	-14	-7	-4	-5	-9	-18
35°	-37	-29	-14	-7	-4	-5	-9	-17
40°	-36	-28	-14	-7	-4	-5	-8	-16
45°	-35	-27	-14	-7	-4	-5	-8	-15

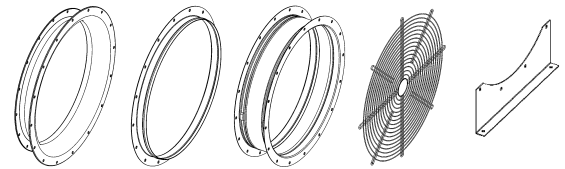

Accessories : see pages 100-102

Design	Pitch Angle	Type (G finish)	Part N°	Type (H finish)	Part N°	L1(mm)	L(mm)	Weight (kg)
K	25°	FV40V-4DK.87.25.G	150132	FV40V-4DK.87.25.H	150133	270	260	15
	30°	FV40V-4DK.97.30.G	150136	FV40V-4DK.97.30.H	150137	295	260	16
	35°	FV40V-4DK.97.35.G	150140	FV40V-4DK.97.35.H	150141	295	260	16
	40°	FV40V-4DK.A7.40.G	150144	FV40V-4DK.A7.40.H	150145	338	260	18
	45°	FV40V-4DK.A7.45.G	150148	FV40V-4DK.A7.45.H	150149	338	260	18
F	25°	FV40V-4DF.87.25.G	150134	FV40V-4DF.87.25.H	150135	---	470	20
	30°	FV40V-4DF.97.30.G	150138	FV40V-4DF.97.30.H	150139	---	470	20
	35°	FV40V-4DF.97.35.G	150142	FV40V-4DF.97.35.H	150143	---	470	21
	40°	FV40V-4DF.A7.40.G	150146	FV40V-4DF.A7.40.H	150147	---	470	22
	45°	FV40V-4DF.A7.45.G	150150	FV40V-4DF.A7.45.H	150151	---	470	22

FV40V-6D

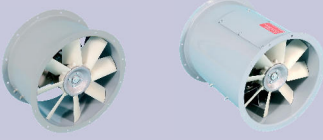

50Hz Motor	U	I	P ₂	n	
	V	A	kW	min ⁻¹	
25°	63 M	400	0,44	0,09	850
30°	63 M	400	0,44	0,09	850
35°	63 M	400	0,44	0,09	850
40°	63 M	400	0,44	0,09	850
45°	63 M	400	0,44	0,09	850

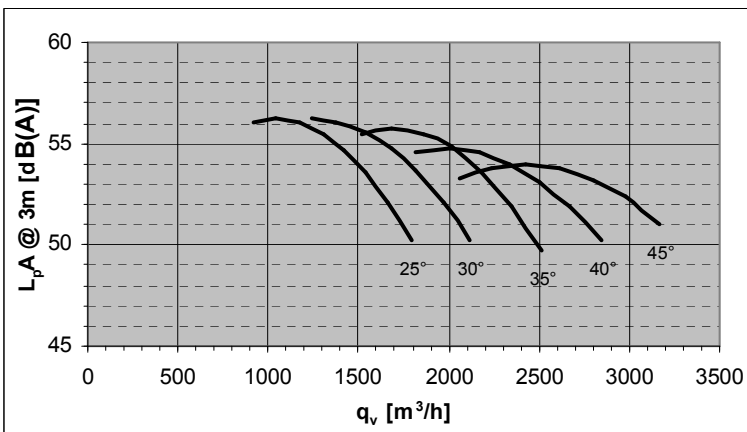
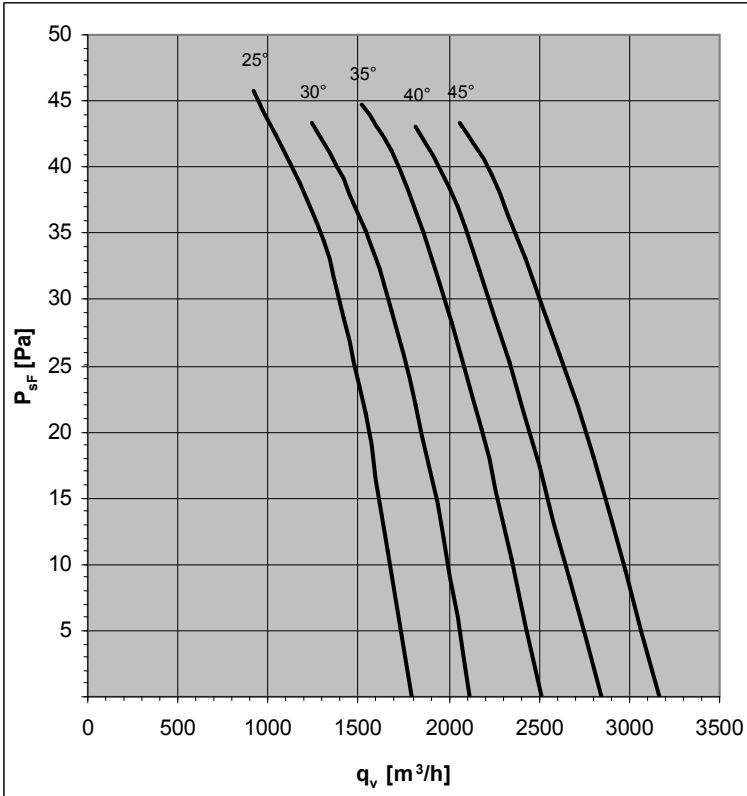

Design K

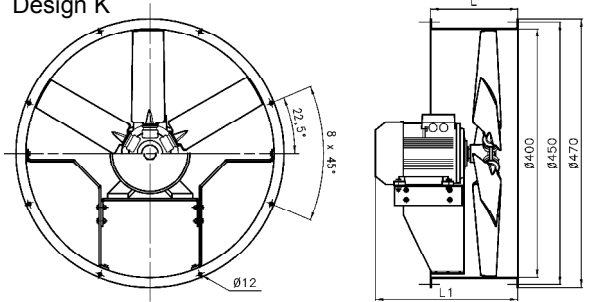

Design F

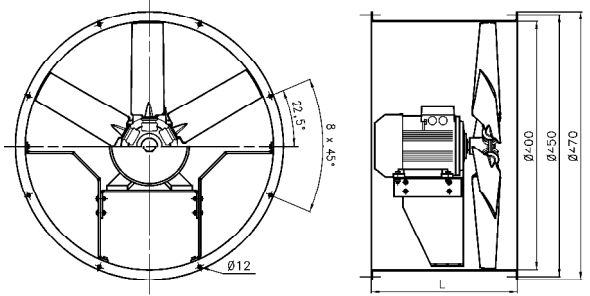

Pitch Angle	Relative spectrum							
	63	125	250	500	1000	2000	4000	8000
25°	-34	-27	-12	-6	-3	-5	-9	-16
30°	-33	-26	-12	-6	-3	-4	-8	-16
35°	-32	-25	-12	-6	-3	-4	-8	-15
40°	-31	-24	-12	-6	-3	-4	-7	-14
45°	-31	-24	-12	-6	-3	-4	-7	-13

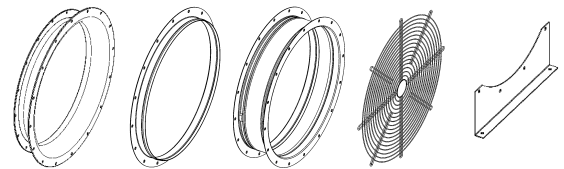

Accessories : see pages 100-102

Design	Pitch Angle	Type (G finish)	Part N°	Type (H finish)	Part N°	L1(mm)	L(mm)	Weight (kg)
K	25°	FV40V-6DK.97.25.G	150152	FV40V-6DK.97.25.H	150153	295	260	16
	30°	FV40V-6DK.97.30.G	150156	FV40V-6DK.97.30.H	150157	295	260	16
	35°	FV40V-6DK.97.35.G	150160	FV40V-6DK.97.35.H	150161	295	260	16
	40°	FV40V-6DK.97.40.G	150164	FV40V-6DK.97.40.H	150165	295	260	16
	45°	FV40V-6DK.97.45.G	150168	FV40V-6DK.97.45.H	150169	295	260	16
F	25°	FV40V-6DF.97.25.G	150154	FV40V-6DF.97.25.H	150155	---	470	21
	30°	FV40V-6DF.97.30.G	150158	FV40V-6DF.97.30.H	150159	---	470	21
	35°	FV40V-6DF.97.35.G	150162	FV40V-6DF.97.35.H	150163	---	470	21
	40°	FV40V-6DF.97.40.G	150166	FV40V-6DF.97.40.H	150167	---	470	21
	45°	FV40V-6DF.97.45.G	150170	FV40V-6DF.97.45.H	150171	---	470	21

FV45V-2D

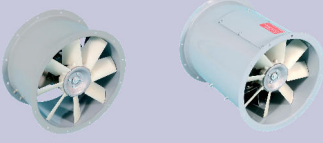

50Hz Motor	U	I	P ₂	n	
	V	A	kW	min ⁻¹	
25°	90 L	400	4,55	2,2	2880
30°	90 L	400	4,55	2,2	2880
35°	100 L	400	6	3	2835
40°	112 M	400	7,9	4	2930
45°	112 M	400	10,6	5,5	2905

Standard Temperature Range : -30°C / +50°C

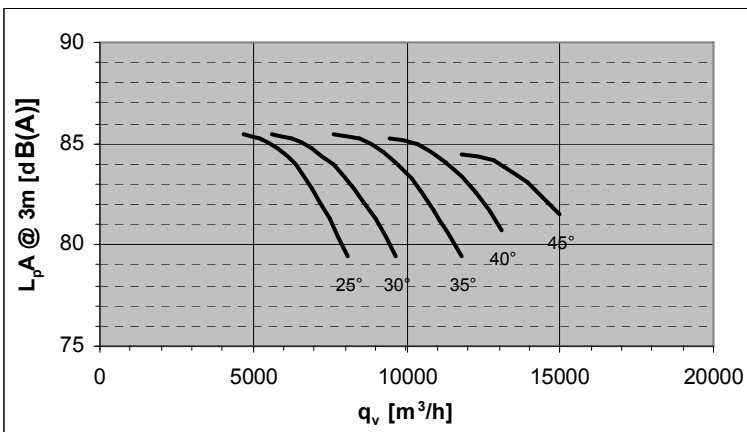
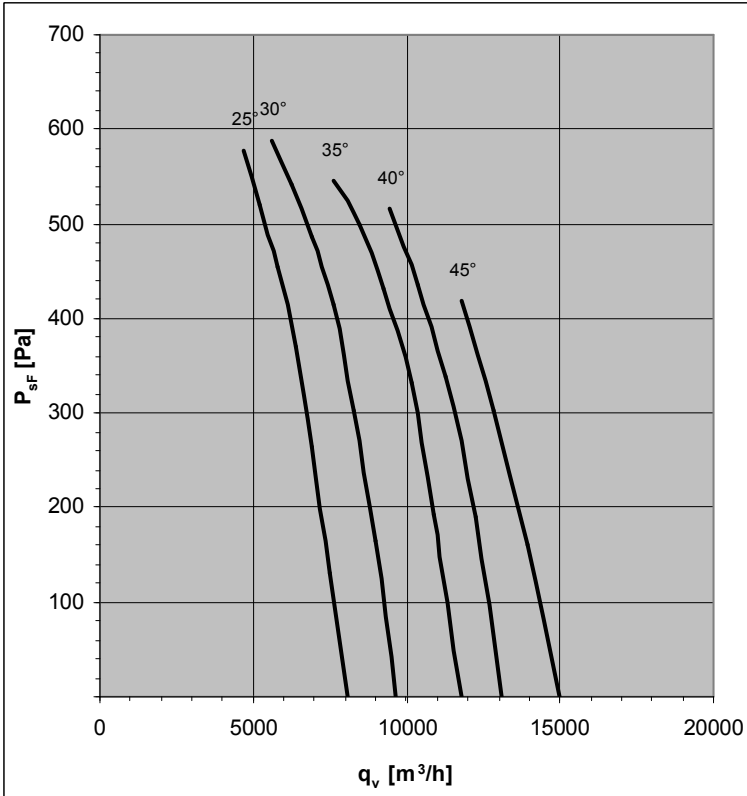

Design K

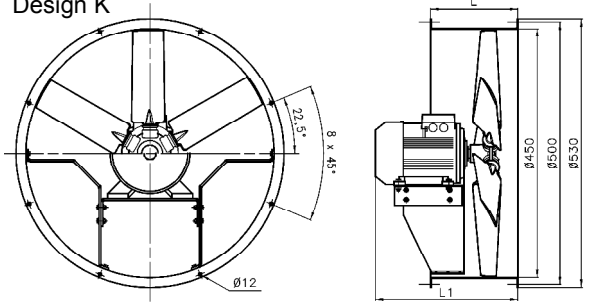

Design F

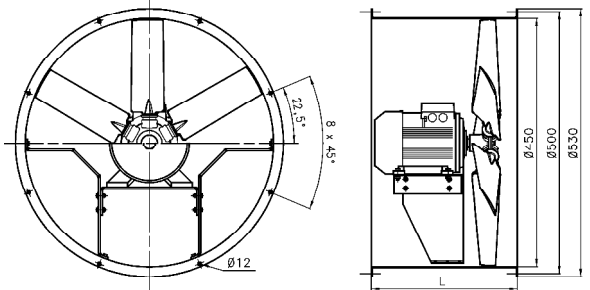

Pitch Angle	Relative spectrum							
	63	125	250	500	1000	2000	4000	8000
25°	-49	-38	-17	-8	-5	-7	-12	-23
30°	-47	-37	-17	-8	-5	-6	-12	-22
35°	-46	-36	-17	-8	-4	-6	-11	-21
40°	-45	-35	-18	-9	-5	-6	-10	-20
45°	-45	-34	-18	-9	-5	-6	-10	-19

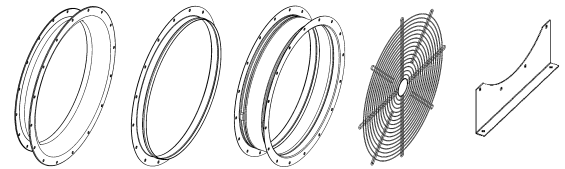

Accessories : see pages 100-102

Design	Pitch Angle	Type (G finish)	Part N°	Type (H finish)	Part N°	L1(mm)	L(mm)	Weight (kg)
K	25°	FV45V-2DK.D7.25.G	150192	FV45V-2DK.D7.25.H	150193	392	260	31
	30°	FV45V-2DK.D7.30.G	150196	FV45V-2DK.D7.30.H	150197	392	260	31
	35°	FV45V-2DK.E7.35.G	150200	FV45V-2DK.E7.35.H	150201	460	260	36
	40°	FV45V-2DK.F7.40.G	150204	FV45V-2DK.F7.40.H	150205	460	385	49
	45°	FV45V-2DK.F7.45.G	150208	FV45V-2DK.F7.45.H	150209	460	385	59
F	25°	FV45V-2DF.D7.25.G	150194	FV45V-2DF.D7.25.H	150195	---	470	36
	30°	FV45V-2DF.D7.30.G	150198	FV45V-2DF.D7.30.H	150199	---	470	36
	35°	FV45V-2DF.E7.35.G	150202	FV45V-2DF.E7.35.H	150203	---	470	41
	40°	FV45V-2DF.F7.40.G	150206	FV45V-2DF.F7.40.H	150207	---	530	53
	45°	FV45V-2DF.F7.45.G	150210	FV45V-2DF.F7.45.H	150211	---	530	63

FV45V-4D

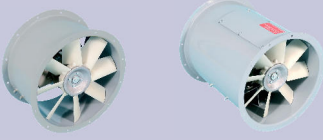

50Hz Motor	U	I	P ₂	n	
	V	A	kW	min ⁻¹	
25°	63 M	400	0,58	0,18	1350
30°	71 M	400	0,77	0,25	1350
35°	71 M	400	1,06	0,37	1370
40°	71 M	400	1,06	0,37	1370
45°	80 M	400	1,93	0,55	1395

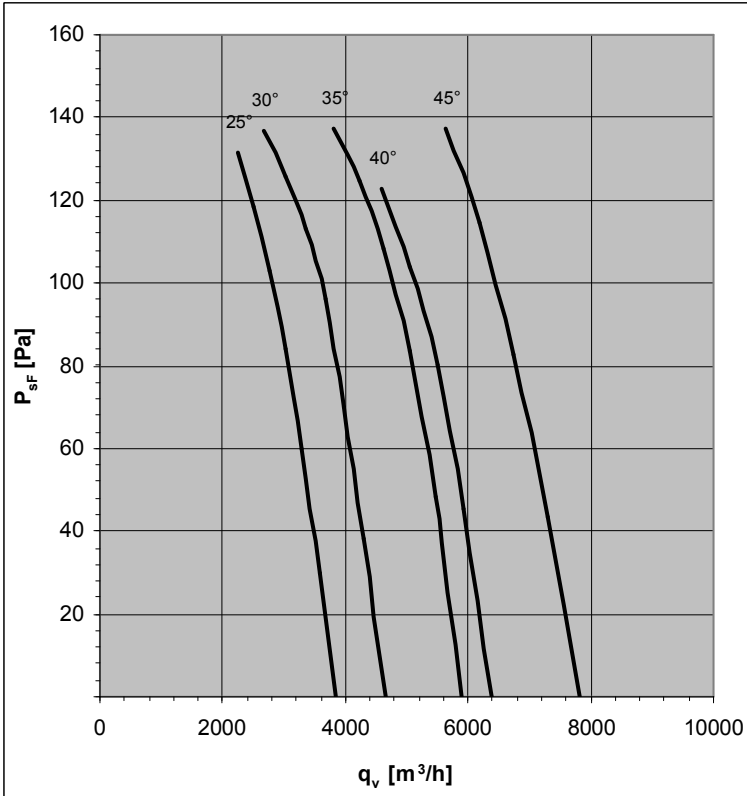

Design K

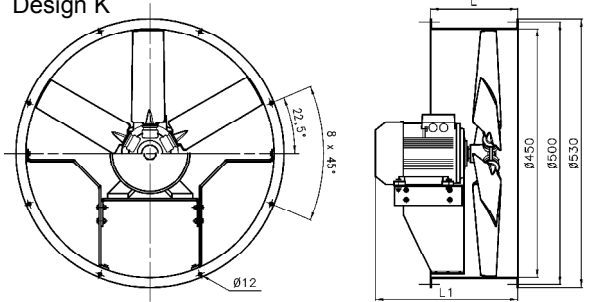

Design F

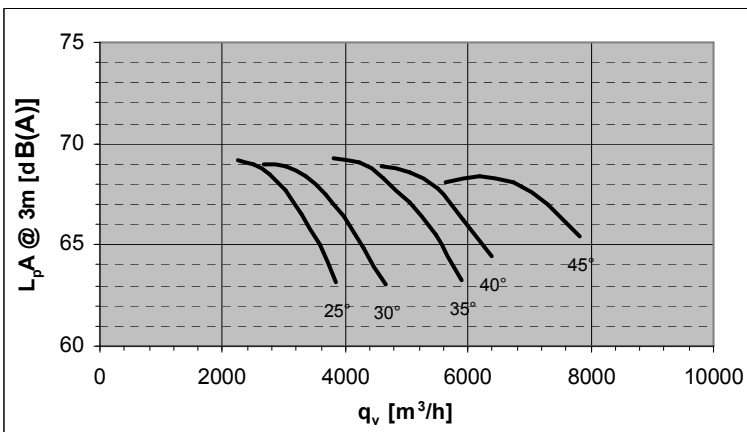
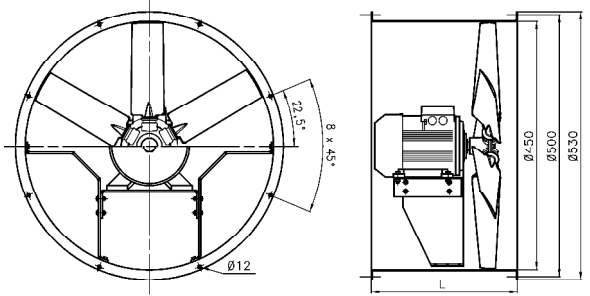

Pitch Angle	Relative spectrum							
	63	125	250	500	1000	2000	4000	8000
25°	-40	-32	-14	-7	-4	-6	-10	-20
30°	-39	-31	-14	-7	-4	-5	-10	-18
35°	-38	-30	-14	-7	-4	-5	-9	-17
40°	-38	-29	-15	-7	-4	-5	-9	-17
45°	-37	-29	-15	-7	-4	-5	-8	-16

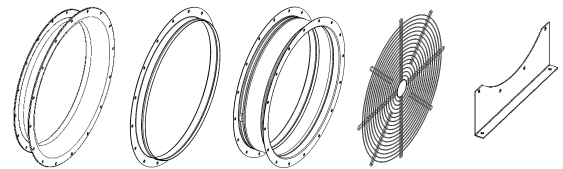

Accessories : see pages 100-102

Design	Pitch Angle	Type (G finish)	Part N°	Type (H finish)	Part N°	L1(mm)	L(mm)	Weight (kg)
K	25°	FV45V-4DK.97.25.G	150212	FV45V-4DK.97.25.H	150213	343	260	20
	30°	FV45V-4DK.A7.30.G	150216	FV45V-4DK.A7.30.H	150217	343	260	21
	35°	FV45V-4DK.A7.35.G	150220	FV45V-4DK.A7.35.H	150221	343	260	22
	40°	FV45V-4DK.A7.40.G	150224	FV45V-4DK.A7.40.H	150225	343	260	22
	45°	FV45V-4DK.B7.45.G	150228	FV45V-4DK.B7.45.H	150229	343	260	25
F	25°	FV45V-4DF.97.25.G	150214	FV45V-4DF.97.25.H	150215	---	470	25
	30°	FV45V-4DF.A7.30.G	150218	FV45V-4DF.A7.30.H	150219	---	470	26
	35°	FV45V-4DF.A7.35.G	150222	FV45V-4DF.A7.35.H	150223	---	470	27
	40°	FV45V-4DF.A7.40.G	150226	FV45V-4DF.A7.40.H	150227	---	470	27
	45°	FV45V-4DF.B7.45.G	150230	FV45V-4DF.B7.45.H	150231	---	470	30

FV45V-6D



50Hz Motor	U	I	P ₂	n	
	V	A	kW	min ⁻¹	
25°	63 M	400	0,44	0,09	850
30°	63 M	400	0,44	0,09	850
35°	63 M	400	0,44	0,09	850
40°	63 M	400	0,44	0,09	850
45°	71 M	400	0,72	0,18	850

Standard Temperature Range : -30°C / +50°C

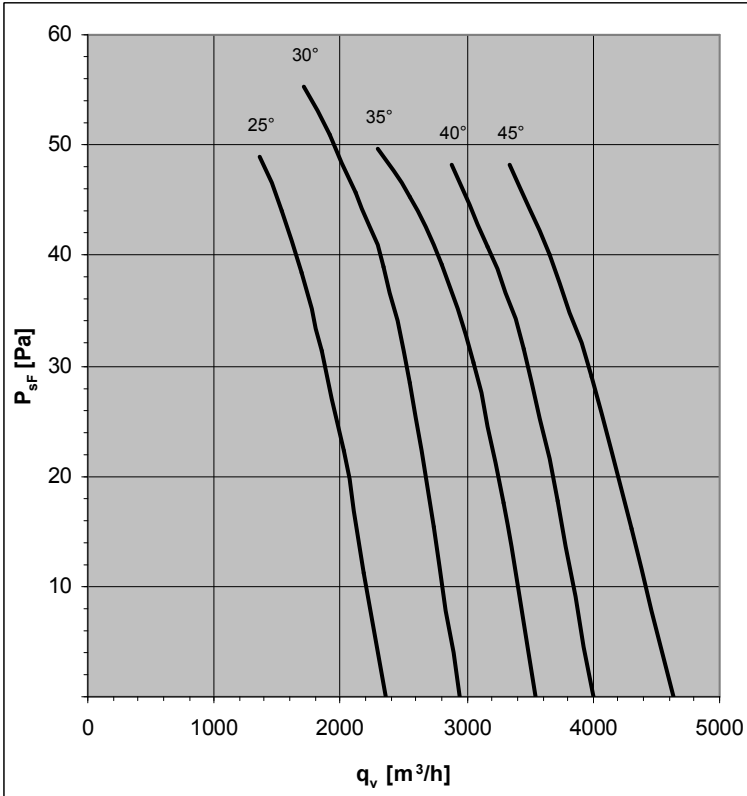

Design K

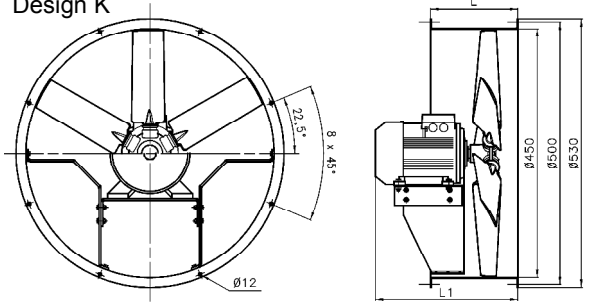

Design F

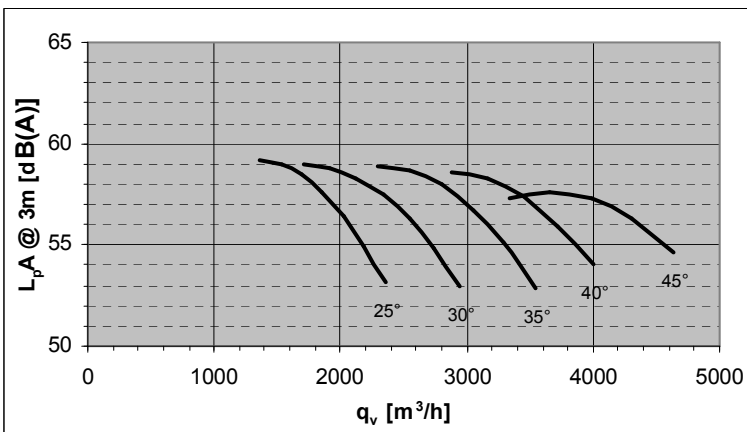
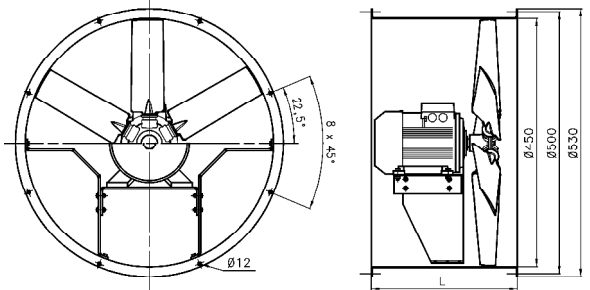

Pitch Angle	Relative spectrum							
	63	125	250	500	1000	2000	4000	8000
25°	-35	-28	-12	-6	-3	-5	-9	-17
30°	-34	-27	-12	-6	-3	-5	-8	-16
35°	-33	-26	-12	-6	-3	-4	-8	-15
40°	-33	-26	-13	-6	-3	-4	-7	-15
45°	-32	-25	-13	-6	-3	-4	-7	-14

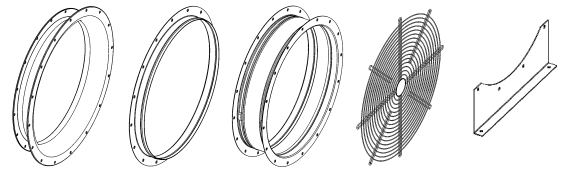

Accessories : see pages 100-102

Design	Pitch Angle	Type (G finish)	Part N°	Type (H finish)	Part N°	L1(mm)	L(mm)	Weight (kg)
K	25°	FV45V-6DK.97.25.G	150232	FV45V-6DK.97.25.H	150233	343	260	20
	30°	FV45V-6DK.97.30.G	150236	FV45V-6DK.97.30.H	150237	343	260	20
	35°	FV45V-6DK.97.35.G	150240	FV45V-6DK.97.35.H	150241	343	260	20
	40°	FV45V-6DK.97.40.G	150244	FV45V-6DK.97.40.H	150245	343	260	20
	45°	FV45V-6DK.A7.45.G	150248	FV45V-6DK.A7.45.H	150249	343	260	21
F	25°	FV45V-6DF.97.25.G	150234	FV45V-6DF.97.25.H	150235	---	470	25
	30°	FV45V-6DF.97.30.G	150238	FV45V-6DF.97.30.H	150239	---	470	25
	35°	FV45V-6DF.97.35.G	150242	FV45V-6DF.97.35.H	150243	---	470	25
	40°	FV45V-6DF.97.40.G	150246	FV45V-6DF.97.40.H	150247	---	470	25
	45°	FV45V-6DF.A7.45.G	150250	FV45V-6DF.A7.45.H	150251	---	470	26

FV50V-2D

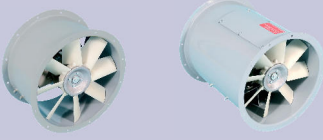

50Hz Motor	U	I	P ₂	n	
	V	A	kW	min ⁻¹	
25°	90 L	400	4,55	2,2	2880
30°	100 L	400	6	3	2835
35°	132 S	400	10,4	5,5	2905
40°	132 S	400	10,4	5,5	2905
45°	132 S	400	14	7,5	2925

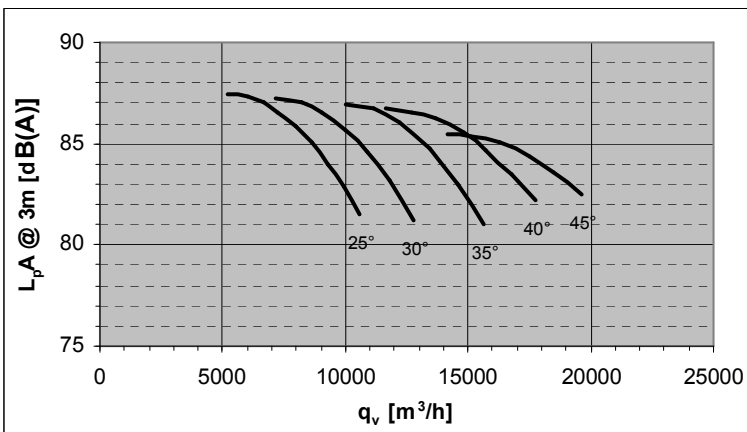
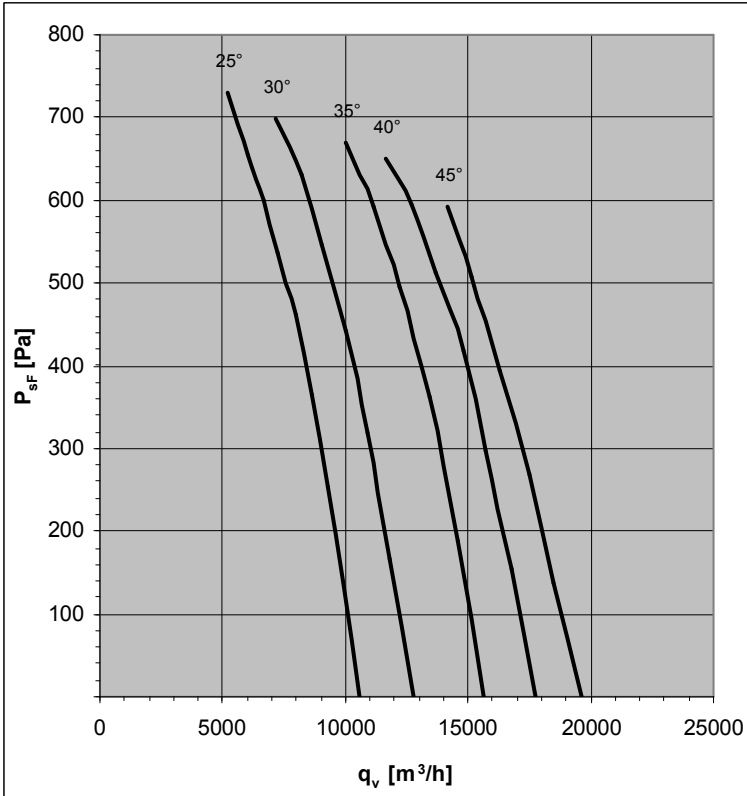

Design K

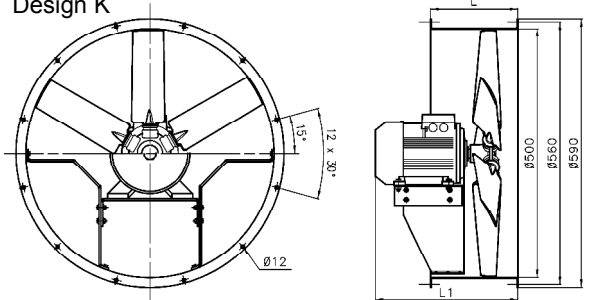

Design F

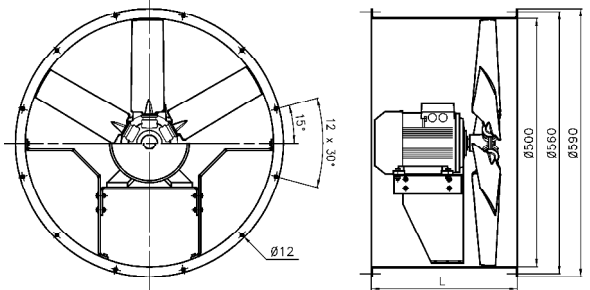

Pitch Angle	Relative spectrum							
	63	125	250	500	1000	2000	4000	8000
25°	-50	-39	-17	-8	-5	-7	-13	-24
30°	-48	-38	-17	-8	-5	-7	-12	-23
35°	-47	-37	-17	-9	-5	-6	-11	-21
40°	-46	-36	-18	-9	-5	-6	-10	-20
45°	-45	-35	-18	-9	-5	-6	-10	-19

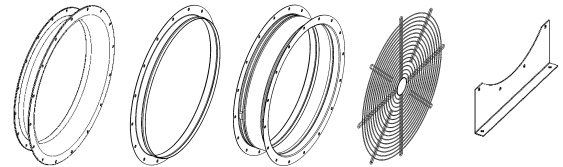

Accessories : see pages 100-102

Design	Pitch Angle	Type (G finish)	Part N°	Type (H finish)	Part N°	L1(mm)	L(mm)	Weight (kg)
K	25°	FV50V-2DK.D7.25.G	150265	FV50V-2DK.D7.25.H	150266	392	260	33
	30°	FV50V-2DK.E7.30.G	150269	FV50V-2DK.E7.30.H	150270	460	260	38
	35°	FV50V-2DK.G7.35.G	150273	FV50V-2DK.G7.35.H	150274	540	385	61
	40°	FV50V-2DK.G7.40.G	150277	FV50V-2DK.G7.40.H	150278	540	385	61
	45°	FV50V-2DK.G7.45.G	150281	FV50V-2DK.G7.45.H	150282	540	385	66
F	25°	FV50V-2DF.D7.25.G	150267	FV50V-2DF.D7.25.H	150268	---	470	39
	30°	FV50V-2DF.E7.30.G	150271	FV50V-2DF.E7.30.H	150272	---	470	43
	35°	FV50V-2DF.G7.35.G	150275	FV50V-2DF.G7.35.H	150276	---	540	65
	40°	FV50V-2DF.G7.40.G	150279	FV50V-2DF.G7.40.H	150280	---	540	65
	45°	FV50V-2DF.G7.45.G	150283	FV50V-2DF.G7.45.H	150284	---	540	70

FV50V-4D

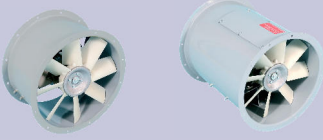

50Hz Motor	U	I	P ₂	n	
	V	A	kW	min ⁻¹	
25°	71 M	400	0,77	0,25	1350
30°	71 M	400	1,06	0,37	1370
35°	80 M	400	1,93	0,55	1395
40°	80 M	400	1,91	0,75	1395
45°	80 M	400	1,91	0,75	1395

Standard Temperature Range : -30°C / +50°C

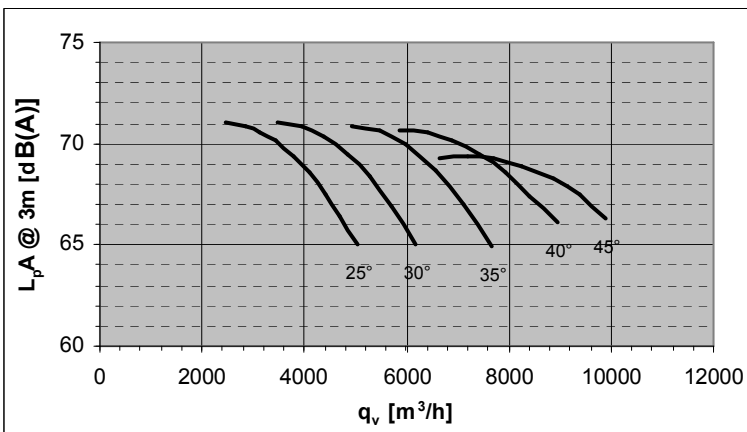
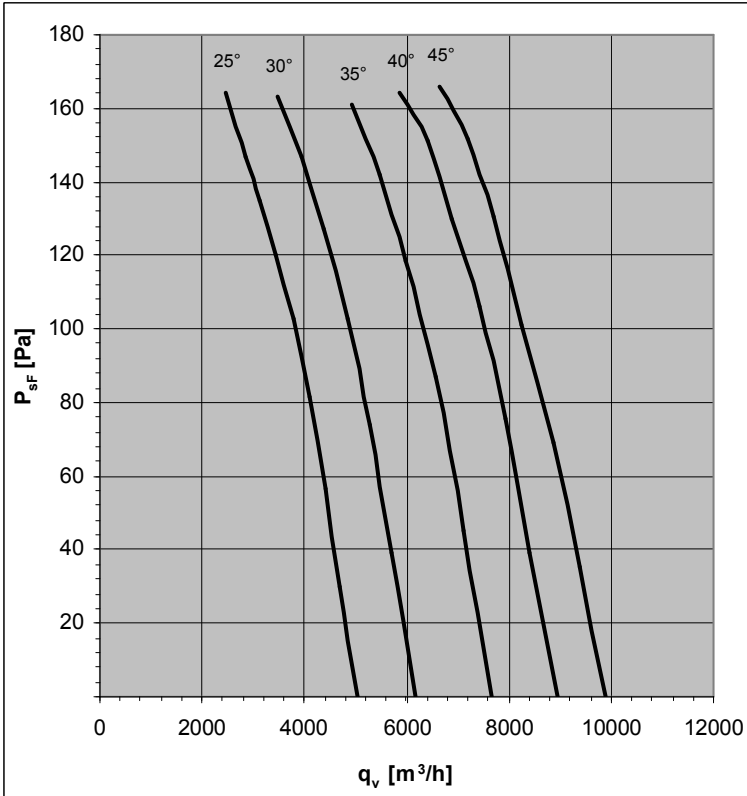

Design K

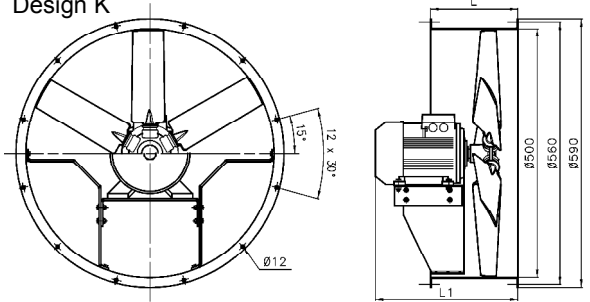

Design F

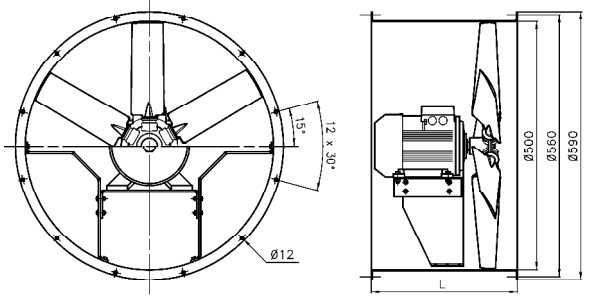

Pitch Angle	Relative spectrum							
	63	125	250	500	1000	2000	4000	8000
25°	-41	-33	-14	-7	-4	-6	-11	-20
30°	-40	-32	-14	-7	-4	-5	-10	-19
35°	-39	-31	-15	-7	-4	-5	-9	-18
40°	-39	-30	-15	-7	-4	-5	-9	-17
45°	-38	-29	-15	-7	-4	-5	-8	-16

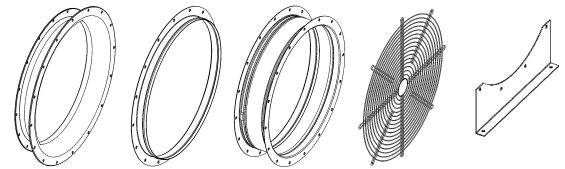

Accessories : see pages 100-102

Design	Pitch Angle	Type (G finish)	Part N°	Type (H finish)	Part N°	L1(mm)	L(mm)	Weight (kg)
K	25°	FV50V-4DK.A7.25.G	150285	FV50V-4DK.A7.25.H	150286	343	260	23
	30°	FV50V-4DK.A7.30.G	150289	FV50V-4DK.A7.30.H	150290	343	260	24
	35°	FV50V-4DK.B7.35.G	150293	FV50V-4DK.B7.35.H	150294	343	260	27
	40°	FV50V-4DK.B7.40.G	150297	FV50V-4DK.B7.40.H	150298	343	260	28
	45°	FV50V-4DK.B7.45.G	150301	FV50V-4DK.B7.45.H	150302	343	260	28
F	25°	FV50V-4DF.A7.25.G	150287	FV50V-4DF.A7.25.H	150288	---	470	28
	30°	FV50V-4DF.A7.30.G	150291	FV50V-4DF.A7.30.H	150292	---	470	29
	35°	FV50V-4DF.B7.35.G	150295	FV50V-4DF.B7.35.H	150296	---	470	32
	40°	FV50V-4DF.B7.40.G	150299	FV50V-4DF.B7.40.H	150300	---	470	33
	45°	FV50V-4DF.B7.45.G	150303	FV50V-4DF.B7.45.H	150304	---	470	33

FV50V-6D

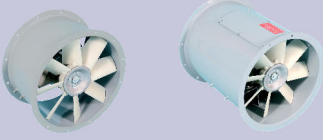

50Hz Motor	U	I	P ₂	n	
	V	A	kW	min ⁻¹	
25°	63 M	400	0,44	0,09	850
30°	63 M	400	0,44	0,09	850
35°	71 M	400	0,72	0,18	850
40°	71 M	400	0,72	0,18	850
45°	71 M	400	0,72	0,18	850

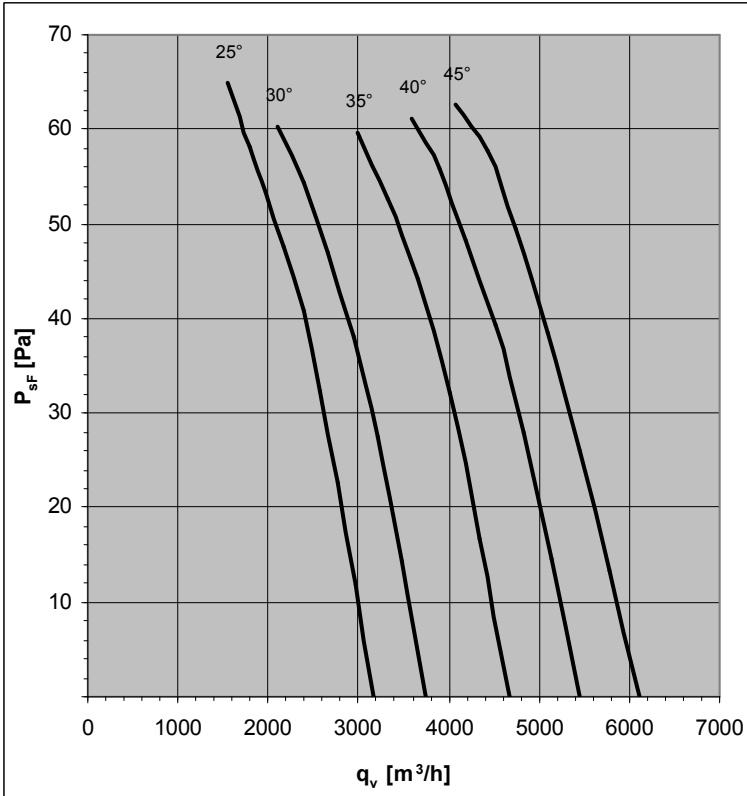

Design K

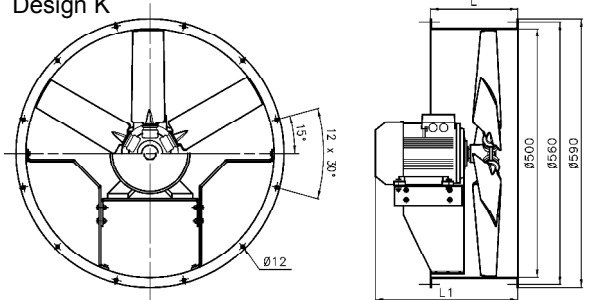

Design F

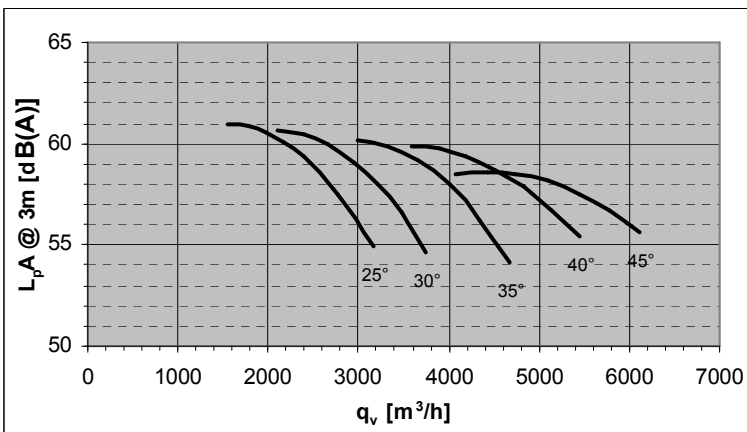
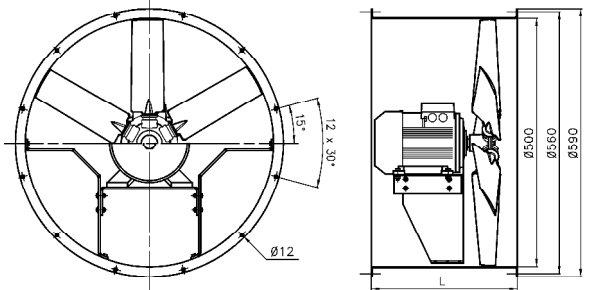

Pitch Angle	Relative spectrum							
	63	125	250	500	1000	2000	4000	8000
25°	-36	-29	-13	-6	-3	-5	-9	-18
30°	-35	-28	-13	-6	-3	-5	-9	-17
35°	-34	-27	-13	-6	-3	-5	-8	-16
40°	-34	-26	-13	-6	-3	-4	-8	-15
45°	-33	-25	-13	-6	-3	-4	-7	-14

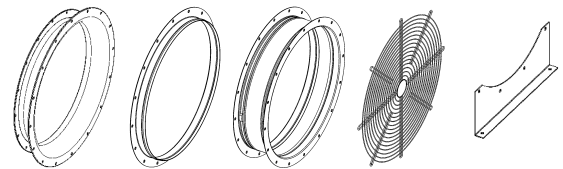

Accessories : see pages 100-102

Design	Pitch Angle	Type (G finish)	Part N°	Type (H finish)	Part N°	L1(mm)	L(mm)	Weight (kg)
K	25°	FV50V-6DK.97.25.G	150305	FV50V-6DK.97.25.H	150306	343	260	22
	30°	FV50V-6DK.97.30.G	150309	FV50V-6DK.97.30.H	150310	343	260	22
	35°	FV50V-6DK.A7.35.G	150313	FV50V-6DK.A7.35.H	150314	343	260	23
	40°	FV50V-6DK.A7.40.G	150317	FV50V-6DK.A7.40.H	150318	343	260	23
	45°	FV50V-6DK.A7.45.G	150321	FV50V-6DK.A7.45.H	150322	343	260	23
F	25°	FV50V-6DF.97.25.G	150307	FV50V-6DF.97.25.H	150308	---	470	27
	30°	FV50V-6DF.97.30.G	150311	FV50V-6DF.97.30.H	150312	---	470	27
	35°	FV50V-6DF.A7.35.G	150315	FV50V-6DF.A7.35.H	150316	---	470	28
	40°	FV50V-6DF.A7.40.G	150319	FV50V-6DF.A7.40.H	150320	---	470	28
	45°	FV50V-6DF.A7.45.G	150323	FV50V-6DF.A7.45.H	150324	---	470	28

FV56V-4D

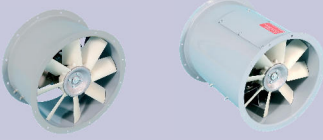

50Hz Motor	U	I	P ₂	n	
	V	A	kW	min ⁻¹	
30°	80 M	400	1,93	0,55	1395
35°	80 M	400	1,91	0,75	1395
40°	90 S	400	2,55	1,1	1415
45°	90 S	400	2,55	1,1	1415
50°	90 L	400	3,4	1,5	1420

Standard Temperature Range : -30°C / +50°C

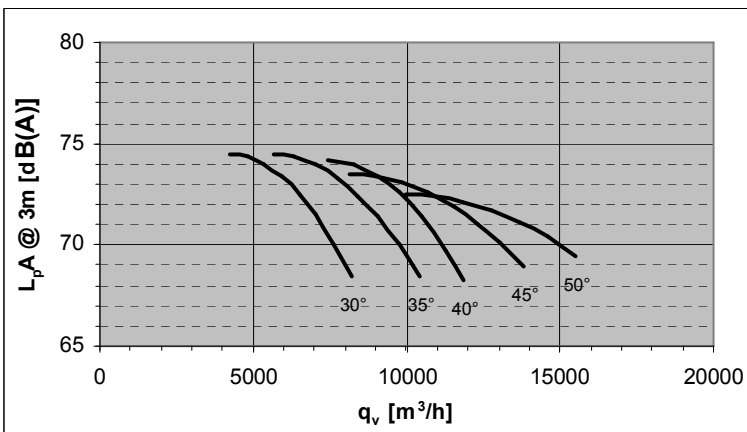
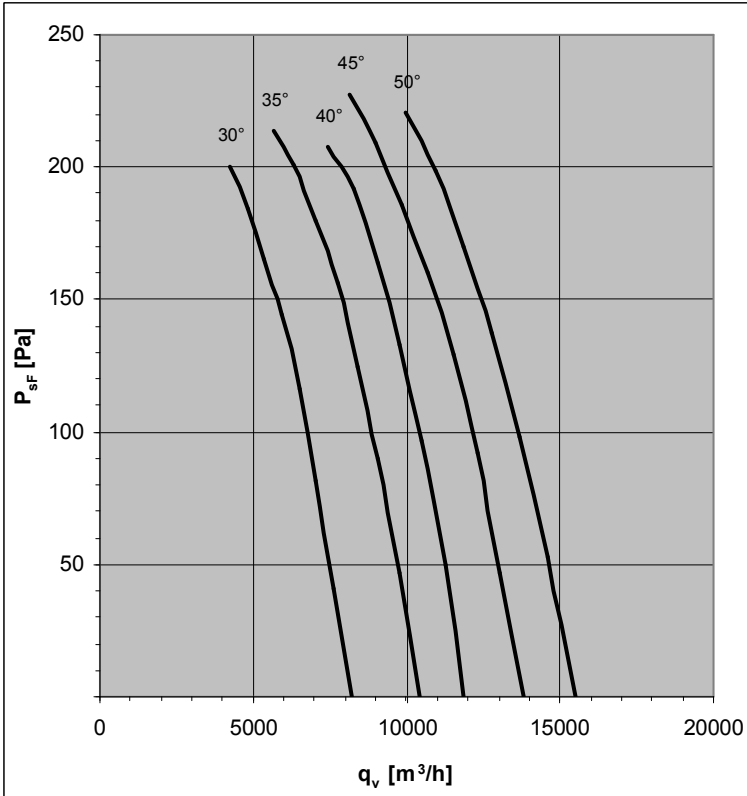

Design K

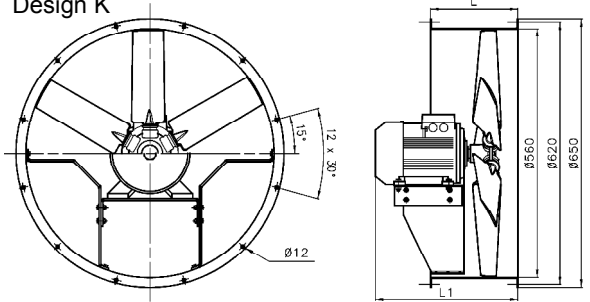

Design F

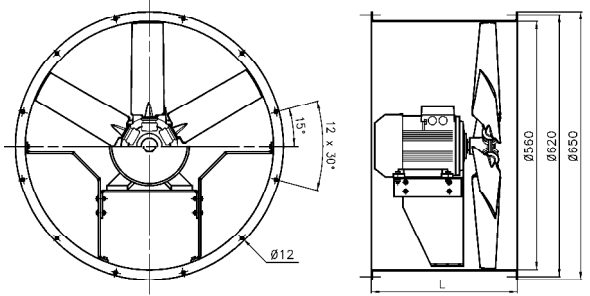

Pitch Angle	Relative spectrum							
	63	125	250	500	1000	2000	4000	8000
30°	-43	-34	-15	-7	-4	-6	-11	-21
35°	-42	-33	-15	-7	-4	-6	-10	-20
40°	-41	-32	-15	-7	-4	-5	-10	-19
45°	-40	-31	-15	-8	-4	-5	-9	-18
50°	-39	-30	-16	-8	-4	-5	-8	-17

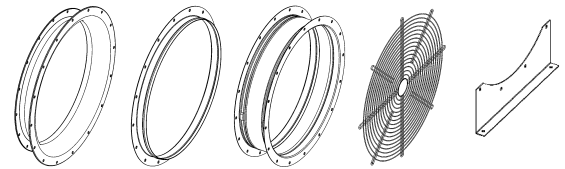

Accessories : see pages 100-102

Design	Pitch Angle	Type (G finish)	Part N°	Type (H finish)	Part N°	L1(mm)	L(mm)	Weight (kg)
K	30°	FV56V-4DK.B7.30.G	150341	FV56V-4DK.B7.30.H	150342	343	260	29
	35°	FV56V-4DK.B7.35.G	150345	FV56V-4DK.B7.35.H	150346	343	260	30
	40°	FV56V-4DK.C7.40.G	150349	FV56V-4DK.C7.40.H	150350	392	260	33
	45°	FV56V-4DK.C7.45.G	150353	FV56V-4DK.C7.45.H	150354	392	260	33
	50°	FV56V-4DK.D7.50.G	150357	FV56V-4DK.D7.50.H	150358	392	260	35
F	30°	FV56V-4DF.B7.30.G	150343	FV56V-4DF.B7.30.H	150344	---	470	35
	35°	FV56V-4DF.B7.35.G	150347	FV56V-4DF.B7.35.H	150348	---	470	36
	40°	FV56V-4DF.C7.40.G	150351	FV56V-4DF.C7.40.H	150352	---	470	39
	45°	FV56V-4DF.C7.45.G	150355	FV56V-4DF.C7.45.H	150356	---	470	39
	50°	FV56V-4DF.D7.50.G	150359	FV56V-4DF.D7.50.H	150360	---	470	42

FV56V-6D



50Hz Motor	U	I	P ₂	n	
	V	A	kW	min ⁻¹	
30°	71 M	400	0,72	0,18	850
35°	71 M	400	0,72	0,18	850
40°	71 M	400	0,79	0,25	830
45°	71 M	400	0,79	0,25	830
50°	80 M	400	1,2	0,37	920

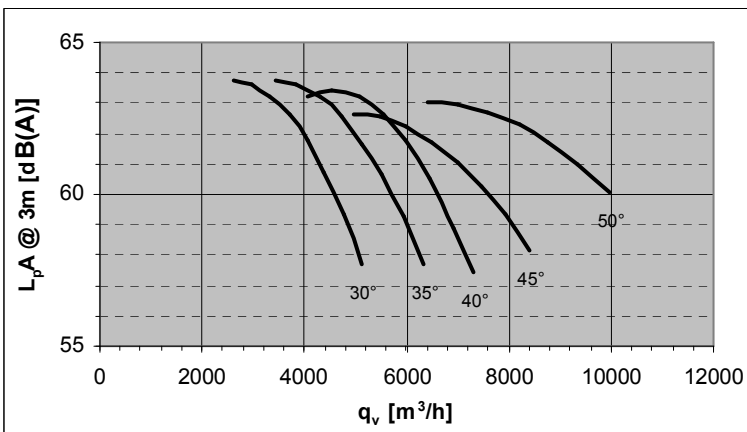
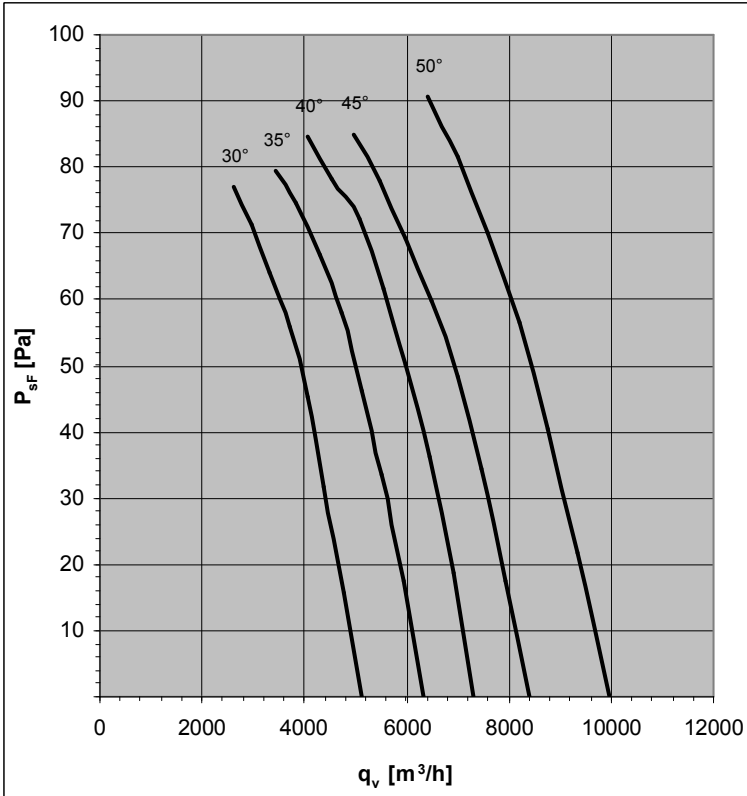

Design K

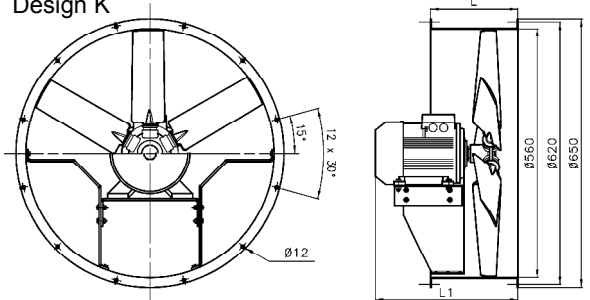

Design F

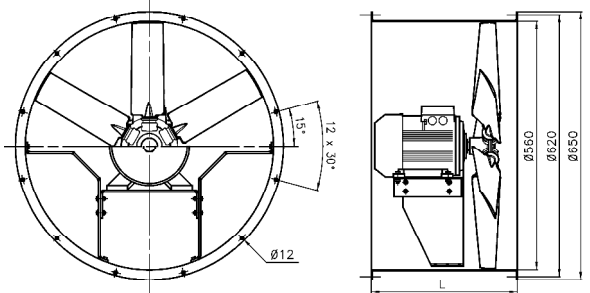

Pitch Angle	Relative spectrum							
	63	125	250	500	1000	2000	4000	8000
30°	-38	-30	-13	-6	-4	-5	-10	-18
35°	-37	-29	-13	-6	-3	-5	-9	-17
40°	-36	-28	-13	-6	-3	-5	-8	-16
45°	-35	-27	-13	-7	-3	-5	-8	-15
50°	-35	-27	-14	-7	-4	-5	-8	-15

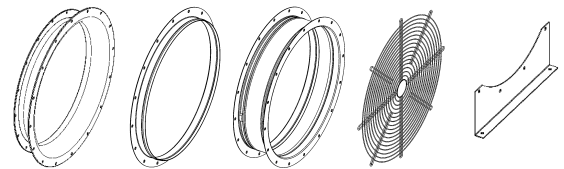

Accessories : see pages 100-102

Design	Pitch Angle	Type (G finish)	Part N°	Type (H finish)	Part N°	L1(mm)	L(mm)	Weight (kg)
K	30°	FV56V-6DK.A7.30.G	150361	FV56V-6DK.A7.30.H	150362	343	260	25
	35°	FV56V-6DK.A7.35.G	150365	FV56V-6DK.A7.35.H	150366	343	260	25
	40°	FV56V-6DK.A7.40.G	150369	FV56V-6DK.A7.40.H	150370	343	260	26
	45°	FV56V-6DK.A7.45.G	150373	FV56V-6DK.A7.45.H	150374	343	260	26
	50°	FV56V-6DK.B7.50.G	150377	FV56V-6DK.B7.50.H	150378	343	260	29
F	30°	FV56V-6DF.A7.30.G	150363	FV56V-6DF.A7.30.H	150364	---	470	31
	35°	FV56V-6DF.A7.35.G	150367	FV56V-6DF.A7.35.H	150368	---	470	31
	40°	FV56V-6DF.A7.40.G	150371	FV56V-6DF.A7.40.H	150372	---	470	32
	45°	FV56V-6DF.A7.45.G	150375	FV56V-6DF.A7.45.H	150376	---	470	32
	50°	FV56V-6DF.B7.50.G	150379	FV56V-6DF.B7.50.H	150380	---	470	35

FV63V-4D

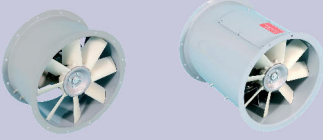

50Hz Motor	U	I	P ₂	n	
	V	A	kW	min ⁻¹	
30°	90 S	400	2,55	1,1	1415
35°	90 L	400	3,4	1,5	1420
40°	90 L	400	3,4	1,5	1420
45°	100 L	400	4,85	2,2	1425
50°	100 L	400	6,2	3	1425

Standard Temperature Range : -30°C / +50°C

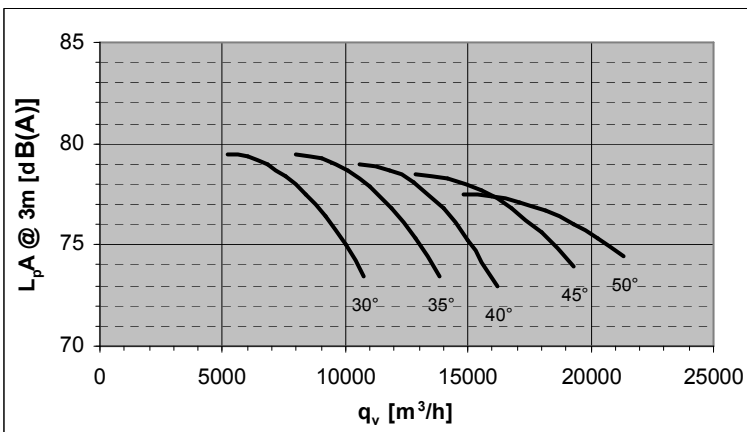
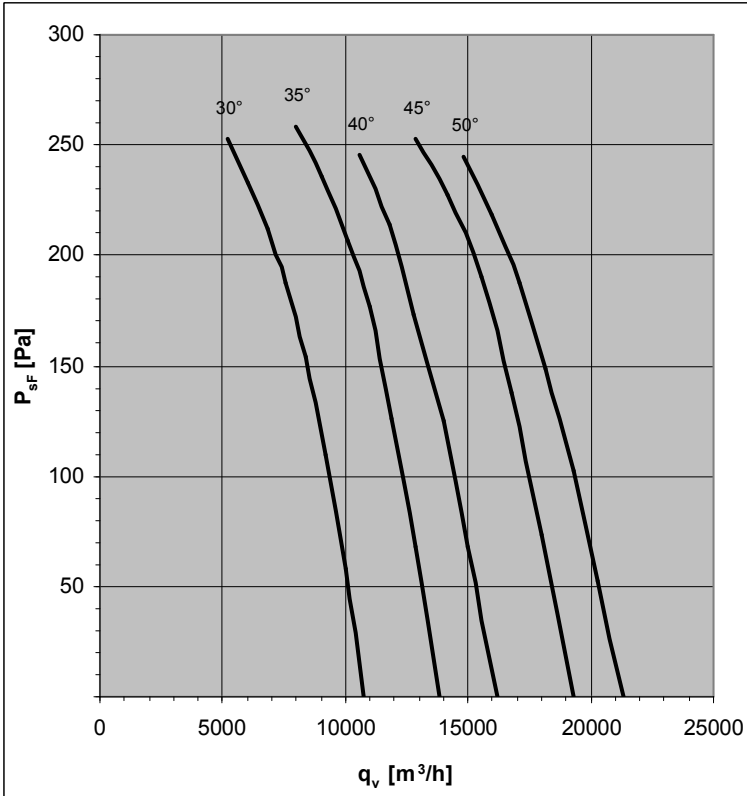

Design K

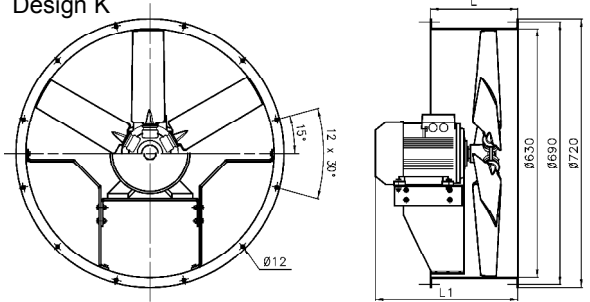

Design F

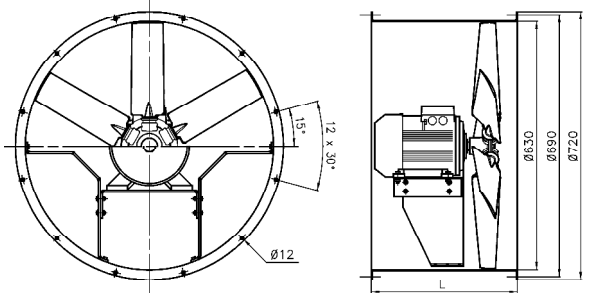

Pitch Angle	Relative spectrum							
	63	125	250	500	1000	2000	4000	8000
30°	-46	-36	-16	-8	-4	-6	-12	-22
35°	-44	-35	-16	-8	-4	-6	-11	-21
40°	-43	-34	-16	-8	-4	-6	-10	-20
45°	-42	-33	-16	-8	-4	-6	-10	-19
50°	-41	-32	-17	-8	-4	-5	-9	-18

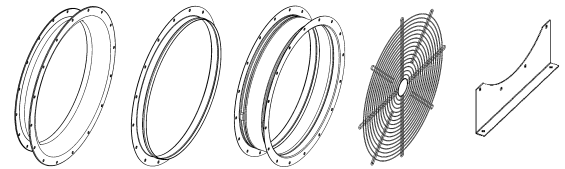

Accessories : see pages 100-102

Design	Pitch Angle	Type (G finish)	Part N°	Type (H finish)	Part N°	L1(mm)	L(mm)	Weight (kg)
K	30°	FV63V-4DK.C7.30.G	150393	FV63V-4DK.C7.30.H	150394	392	260	35
	35°	FV63V-4DK.D7.35.G	150397	FV63V-4DK.D7.35.H	150398	392	260	38
	40°	FV63V-4DK.D7.40.G	150401	FV63V-4DK.D7.40.H	150402	392	260	38
	45°	FV63V-4DK.E7.45.G	150405	FV63V-4DK.E7.45.H	150406	460	260	40
	50°	FV63V-4DK.E7.50.G	150409	FV63V-4DK.E7.50.H	150410	460	260	44
F	30°	FV63V-4DF.C7.30.G	150395	FV63V-4DF.C7.30.H	150396	---	470	43
	35°	FV63V-4DF.D7.35.G	150399	FV63V-4DF.D7.35.H	150400	---	470	45
	40°	FV63V-4DF.D7.40.G	150403	FV63V-4DF.D7.40.H	150404	---	470	45
	45°	FV63V-4DF.E7.45.G	150407	FV63V-4DF.E7.45.H	150408	---	470	48
	50°	FV63V-4DF.E7.50.G	150411	FV63V-4DF.E7.50.H	150412	---	470	52

FV63V-6D

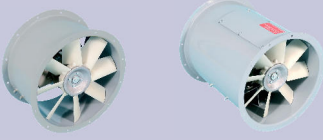

50Hz Motor	U	I	P ₂	n	
	V	A	kW	min ⁻¹	
30°	71 M	400	0,79	0,25	830
35°	80 M	400	1,2	0,37	920
40°	80 M	400	1,6	0,55	910
45°	80 M	400	1,6	0,55	910
50°	90 S	400	2,05	0,75	915

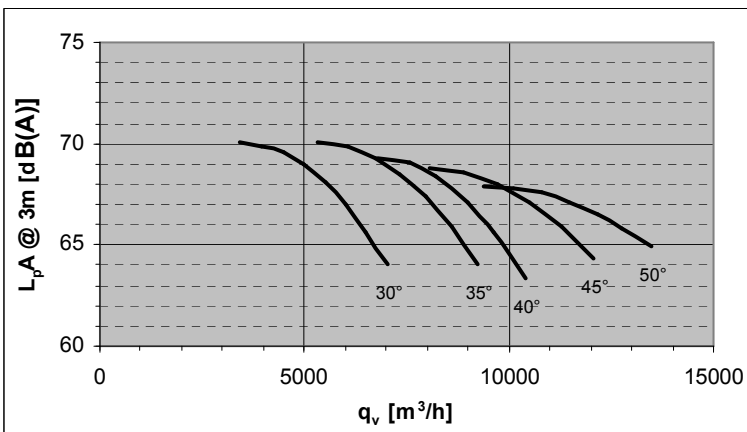
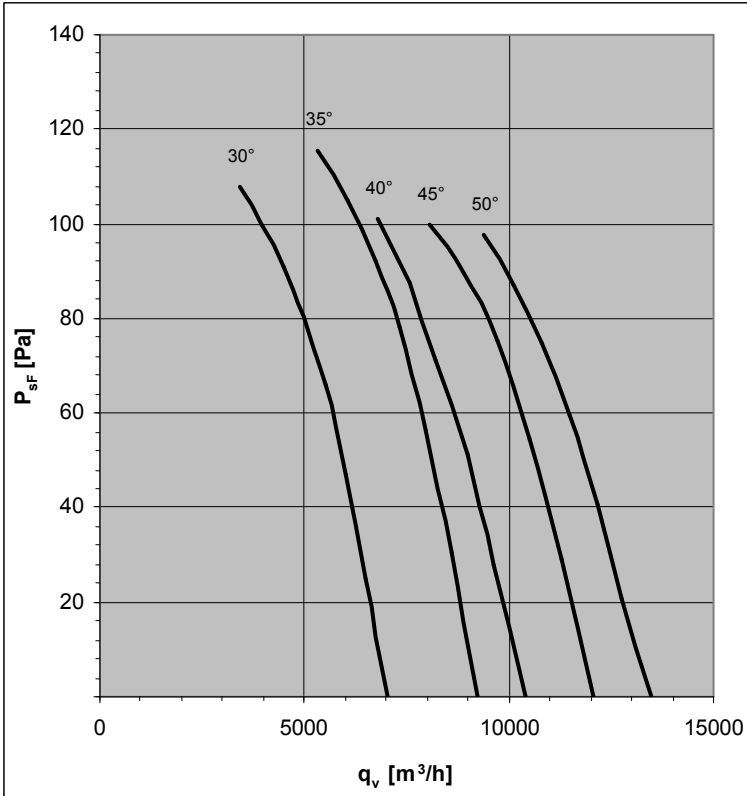

Design K

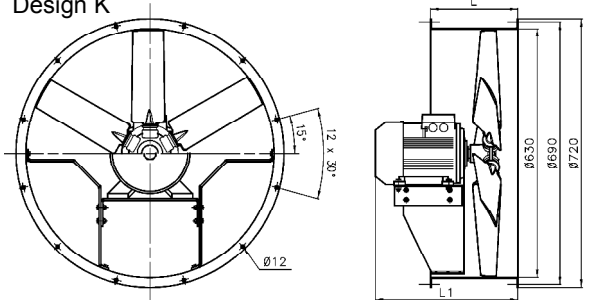

Design F

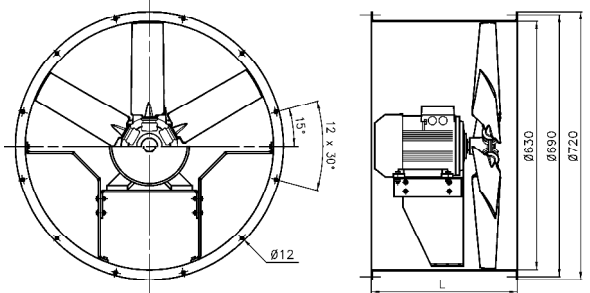

Pitch Angle	Relative spectrum							
	63	125	250	500	1000	2000	4000	8000
30°	-41	-32	-14	-7	-4	-6	-10	-20
35°	-40	-31	-14	-7	-4	-5	-10	-19
40°	-38	-30	-14	-7	-4	-5	-9	-17
45°	-38	-29	-15	-7	-4	-5	-9	-17
50°	-37	-29	-15	-7	-4	-5	-8	-16

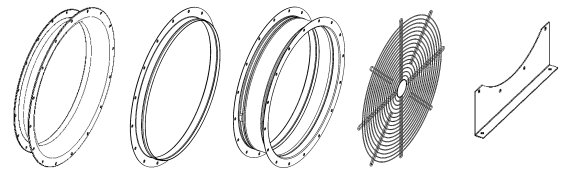

Accessories : see pages 100-102

Design	Pitch Angle	Type (G finish)	Part N°	Type (H finish)	Part N°	L1(mm)	L(mm)	Weight (kg)
K	30°	FV63V-6DK.A7.30.G	150413	FV63V-6DK.A7.30.H	150414	343	260	28
	35°	FV63V-6DK.B7.35.G	150417	FV63V-6DK.B7.35.H	150418	343	260	31
	40°	FV63V-6DK.B7.40.G	150421	FV63V-6DK.B7.40.H	150422	343	260	32
	45°	FV63V-6DK.B7.45.G	150425	FV63V-6DK.B7.45.H	150426	343	260	32
	50°	FV63V-6DK.C7.50.G	150429	FV63V-6DK.C7.50.H	150430	392	260	35
F	30°	FV63V-6DF.A7.30.G	150415	FV63V-6DF.A7.30.H	150416	---	470	36
	35°	FV63V-6DF.B7.35.G	150419	FV63V-6DF.B7.35.H	150420	---	470	39
	40°	FV63V-6DF.B7.40.G	150423	FV63V-6DF.B7.40.H	150424	---	470	40
	45°	FV63V-6DF.B7.45.G	150427	FV63V-6DF.B7.45.H	150428	---	470	40
	50°	FV63V-6DF.C7.50.G	150431	FV63V-6DF.C7.50.H	150432	---	470	43

Standard Temperature Range : -30°C / +50°C

FV63V-8D

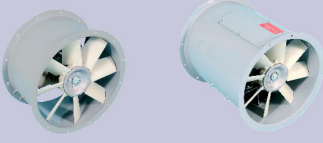

50Hz Motor	U	I	P ₂	n	
	V	A	kW	min ⁻¹	
30°	71 M	400	0,36	0,09	630
35°	71 M	400	0,51	0,12	645
40°	80 M	400	0,75	0,18	675
45°	80 M	400	1,02	0,25	685
50°	80 M	400	1,02	0,25	685

Standard Temperature Range : -30°C / +50°C

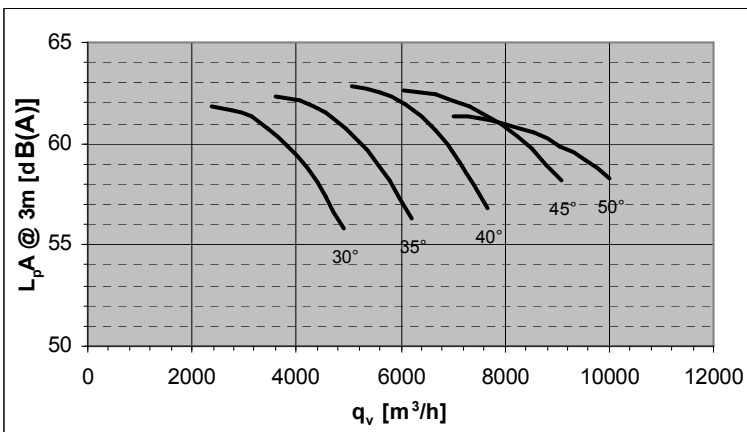
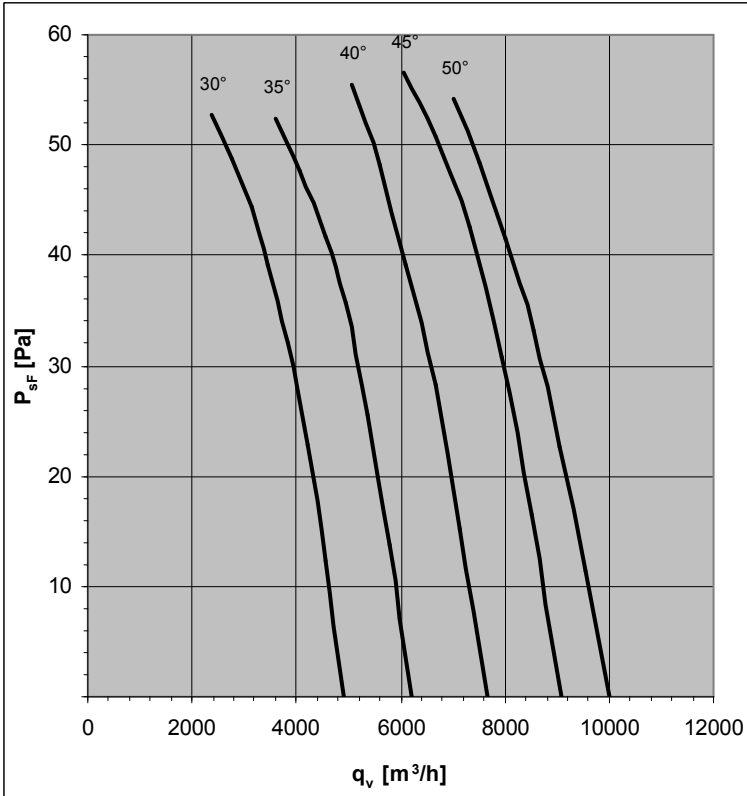

Design K

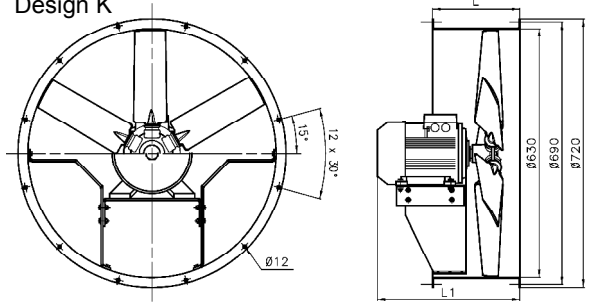

Design F

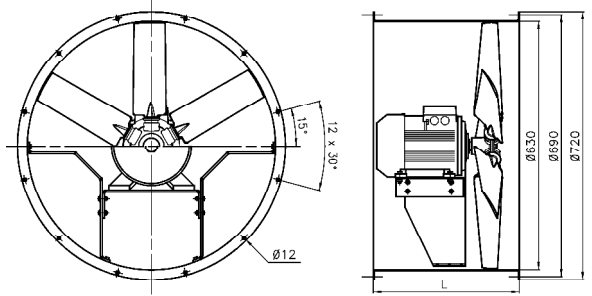

Pitch Angle	Relative spectrum							
	63	125	250	500	1000	2000	4000	8000
30°	-37	-29	-13	-6	-3	-5	-9	-18
35°	-36	-28	-13	-6	-3	-5	-9	-17
40°	-35	-28	-13	-6	-3	-5	-8	-16
45°	-35	-27	-13	-7	-3	-5	-8	-15
50°	-34	-26	-14	-7	-3	-4	-7	-14

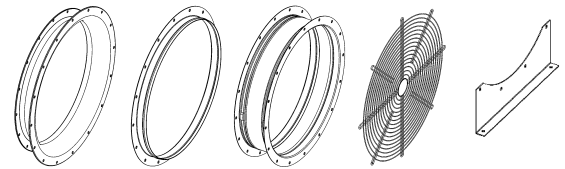

Accessories : see pages 100-102

Design	Pitch Angle	Type (G finish)	Part N°	Type (H finish)	Part N°	L1(mm)	L(mm)	Weight (kg)
K	30°	FV63V-8DK.A7.30.G	150433	FV63V-8DK.A7.30.H	150434	343	260	28
	35°	FV63V-8DK.A7.35.G	150437	FV63V-8DK.A7.35.H	150438	343	260	28
	40°	FV63V-8DK.B7.40.G	150441	FV63V-8DK.B7.40.H	150442	343	260	31
	45°	FV63V-8DK.B7.45.G	150445	FV63V-8DK.B7.45.H	150446	343	260	32
	50°	FV63V-8DK.B7.50.G	150449	FV63V-8DK.B7.50.H	150450	343	260	32
F	30°	FV63V-8DF.A7.30.G	150435	FV63V-8DF.A7.30.H	150436	---	470	36
	35°	FV63V-8DF.A7.35.G	150439	FV63V-8DF.A7.35.H	150440	---	470	36
	40°	FV63V-8DF.B7.40.G	150443	FV63V-8DF.B7.40.H	150444	---	470	39
	45°	FV63V-8DF.B7.45.G	150447	FV63V-8DF.B7.45.H	150448	---	470	40
	50°	FV63V-8DF.B7.50.G	150451	FV63V-8DF.B7.50.H	150452	---	470	40

FV71V-4D

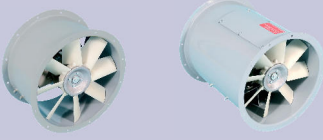

50Hz Motor	U	I	P ₂	n	
	V	A	kW	min ⁻¹	
25°	90 L	400	3,4	1,5	1420
30°	100 L	400	4,85	2,2	1425
35°	100 L	400	6,2	3	1425
40°	112 M	400	8,2	4	1435
45°	112 M	400	8,2	4	1435

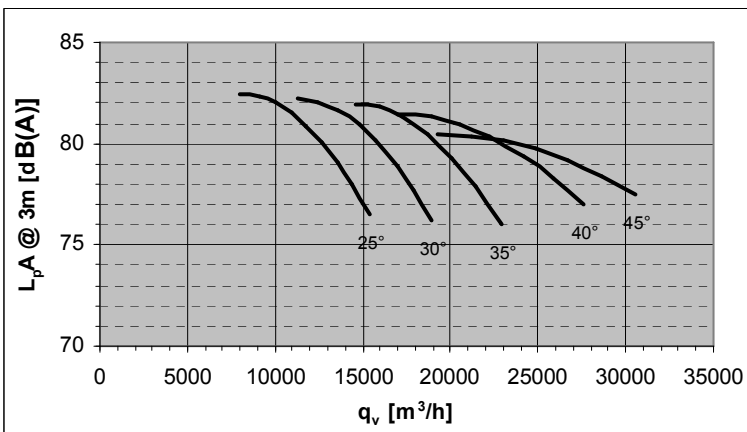
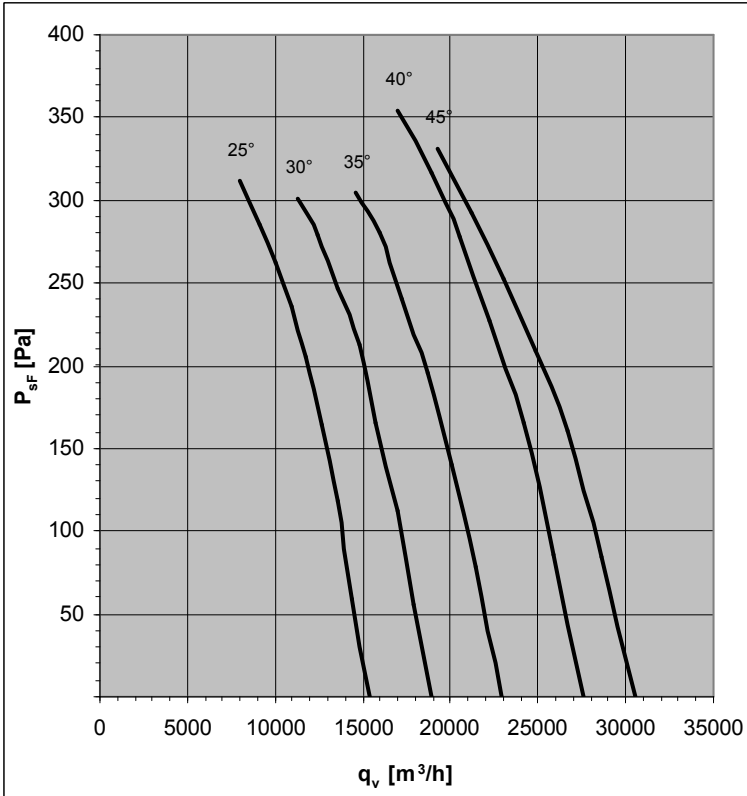

Design K

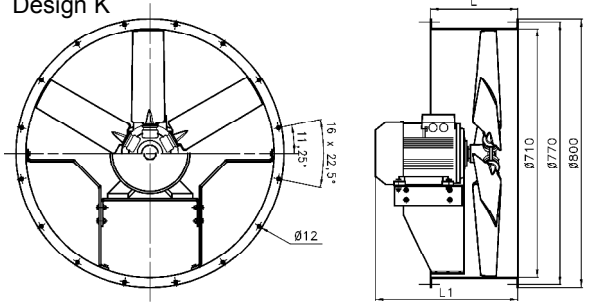

Design F

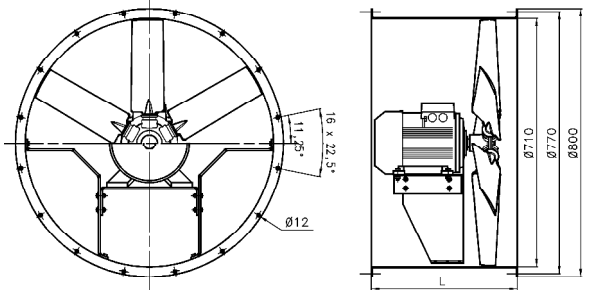

Pitch Angle	Relative spectrum							
	63	125	250	500	1000	2000	4000	8000
25°	-47	-37	-16	-8	-4	-6	-12	-23
30°	-46	-36	-16	-8	-4	-6	-11	-21
35°	-44	-35	-17	-8	-4	-6	-10	-20
40°	-44	-34	-17	-8	-4	-6	-10	-19
45°	-43	-33	-17	-8	-4	-6	-9	-18

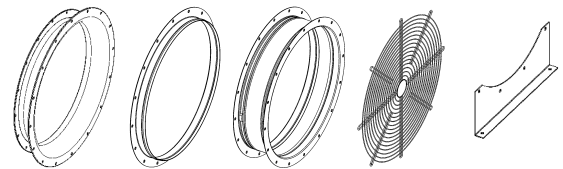

Accessories : see pages 100-102

Design	Pitch Angle	Type (G finish)	Part N°	Type (H finish)	Part N°	L1(mm)	L(mm)	Weight (kg)
K	25°	FV71V-4DK.D7.25.G	150465	FV71V-4DK.D7.25.H	150466	413	280	43
	30°	FV71V-4DK.E7.30.G	150469	FV71V-4DK.E7.30.H	150470	485	280	45
	35°	FV71V-4DK.E7.35.G	150473	FV71V-4DK.E7.35.H	150474	485	280	49
	40°	FV71V-4DK.F7.40.G	150477	FV71V-4DK.F7.40.H	150478	482	400	64
	45°	FV71V-4DK.F7.45.G	150481	FV71V-4DK.F7.45.H	150482	482	400	64
F	25°	FV71V-4DF.D7.25.G	150467	FV71V-4DF.D7.25.H	150468	---	500	52
	30°	FV71V-4DF.E7.30.G	150471	FV71V-4DF.E7.30.H	150472	---	500	55
	35°	FV71V-4DF.E7.35.G	150475	FV71V-4DF.E7.35.H	150476	---	500	59
	40°	FV71V-4DF.F7.40.G	150479	FV71V-4DF.F7.40.H	150480	---	560	71
	45°	FV71V-4DF.F7.45.G	150483	FV71V-4DF.F7.45.H	150484	---	560	71

FV71V-6D

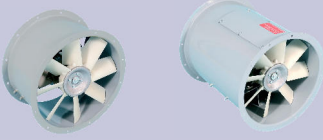

50Hz Motor	U	I	P ₂	n	
	V	A	kW	min ⁻¹	
25°	80 M	400	1,2	0,37	920
30°	80 M	400	1,6	0,55	910
35°	90 S	400	2,05	0,75	915
40°	90 L	400	2,85	1,1	915
45°	90 L	400	2,85	1,1	915

Standard Temperature Range : -30°C / +50°C

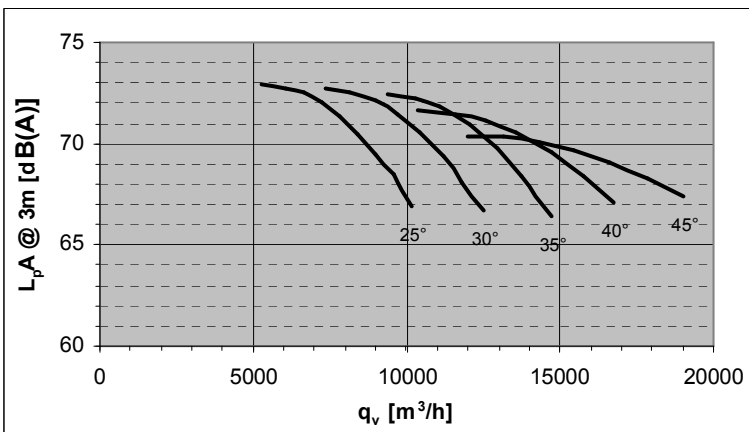
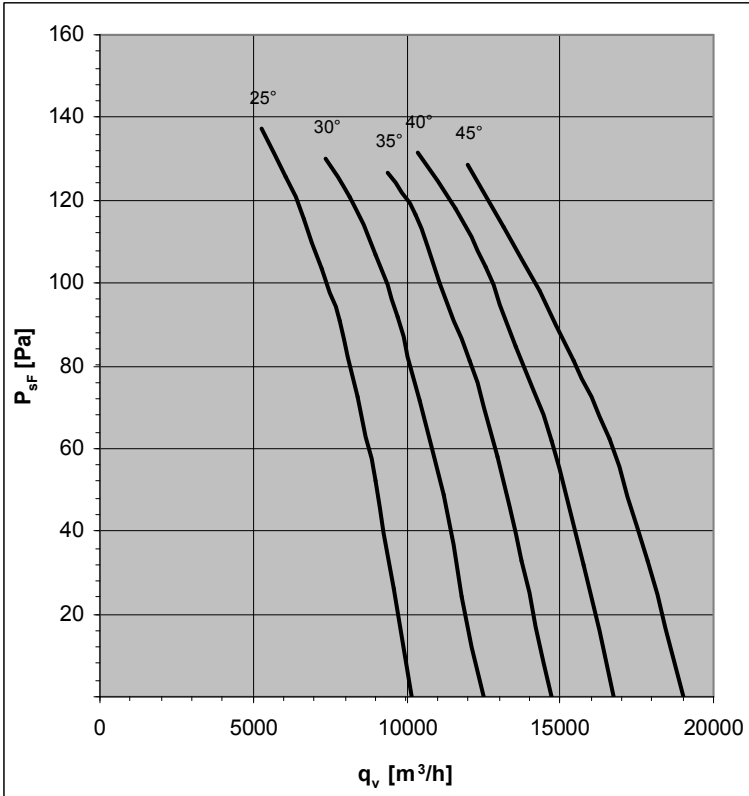

Design K

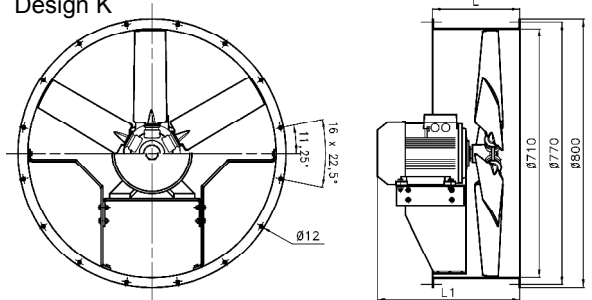

Design F

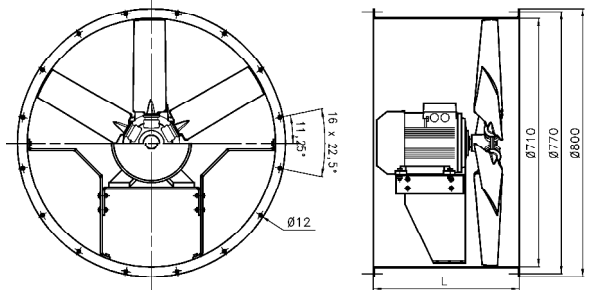

Pitch Angle	Relative spectrum							
	63	125	250	500	1000	2000	4000	8000
25°	-42	-33	-15	-7	-4	-6	-11	-20
30°	-41	-32	-15	-7	-4	-6	-10	-19
35°	-40	-31	-15	-7	-4	-5	-9	-18
40°	-39	-30	-15	-7	-4	-5	-9	-17
45°	-38	-30	-15	-7	-4	-5	-8	-16

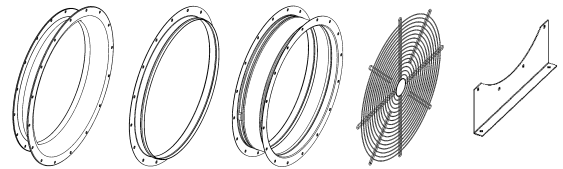

Accessories : see pages 100-102

Design	Pitch Angle	Type (G finish)	Part N°	Type (H finish)	Part N°	L1(mm)	L(mm)	Weight (kg)
K	25°	FV71V-6DK.B7.25.G	150485	FV71V-6DK.B7.25.H	150486	365	280	36
	30°	FV71V-6DK.B7.30.G	150489	FV71V-6DK.B7.30.H	150490	365	280	37
	35°	FV71V-6DK.C7.35.G	150493	FV71V-6DK.C7.35.H	150494	413	280	40
	40°	FV71V-6DK.D7.40.G	150497	FV71V-6DK.D7.40.H	150498	413	280	43
	45°	FV71V-6DK.D7.45.G	150501	FV71V-6DK.D7.45.H	150502	413	280	43
F	25°	FV71V-6DF.B7.25.G	150487	FV71V-6DF.B7.25.H	150488	---	500	46
	30°	FV71V-6DF.B7.30.G	150491	FV71V-6DF.B7.30.H	150492	---	500	47
	35°	FV71V-6DF.C7.35.G	150495	FV71V-6DF.C7.35.H	150496	---	500	50
	40°	FV71V-6DF.D7.40.G	150499	FV71V-6DF.D7.40.H	150500	---	500	53
	45°	FV71V-6DF.D7.45.G	150503	FV71V-6DF.D7.45.H	150504	---	500	53

FV71V-8D

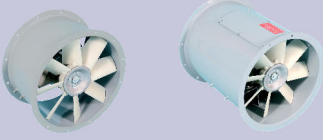

50Hz Motor	U	I	P ₂	n	
	V	A	kW	min ⁻¹	
25°	80 M	400	0,75	0,18	675
30°	80 M	400	1,02	0,25	685
35°	90 S	400	1,14	0,37	675
40°	90 S	400	1,14	0,37	675
45°	90 L	400	1,58	0,55	675

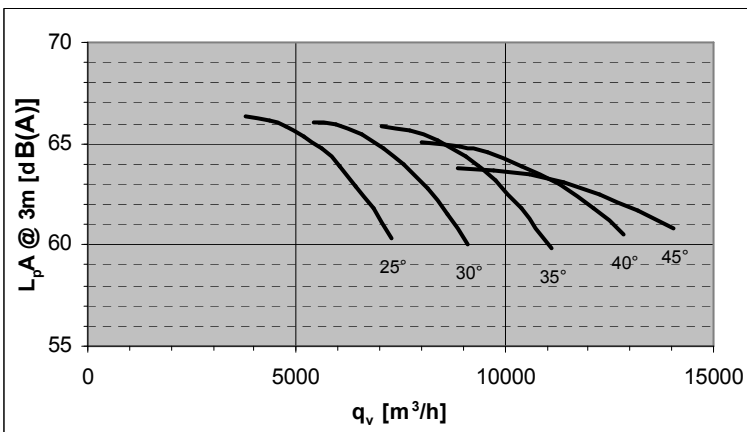
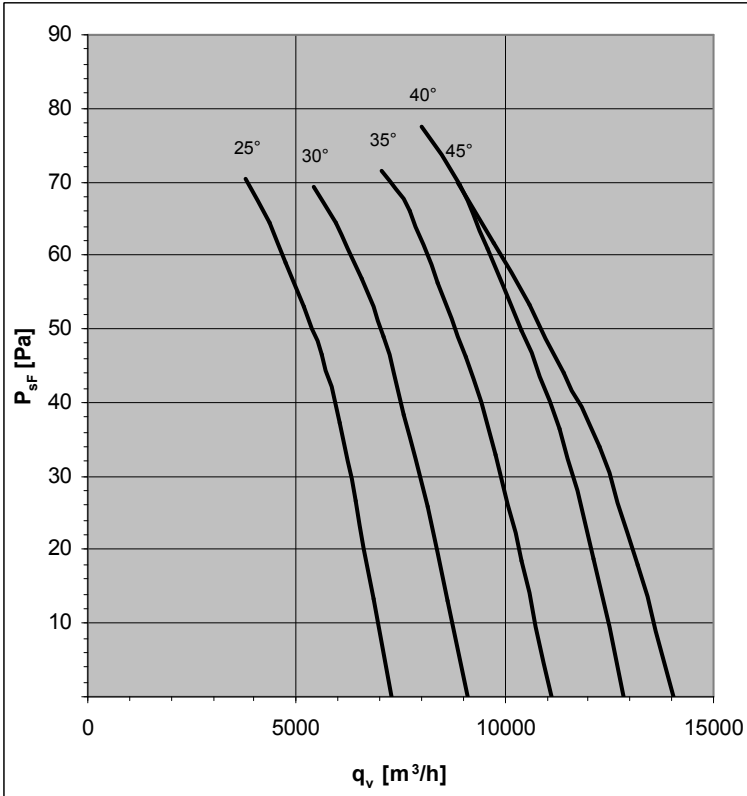

Design K

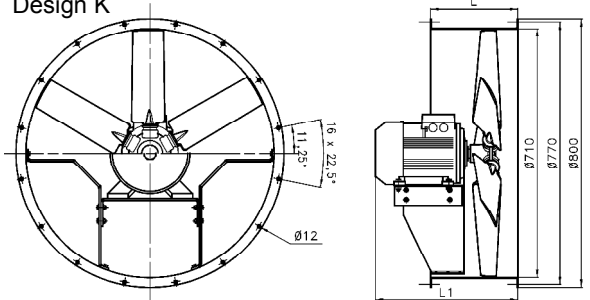

Design F

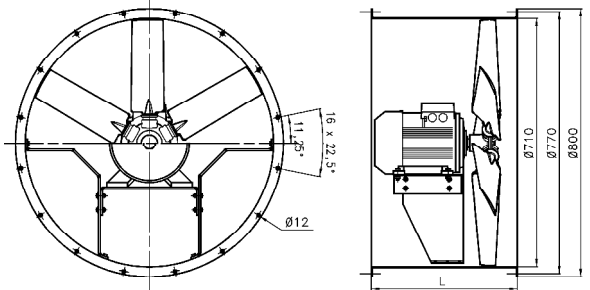

Pitch Angle	Relative spectrum							
	63	125	250	500	1000	2000	4000	8000
25°	-39	-31	-13	-7	-4	-5	-10	-19
30°	-38	-30	-14	-7	-4	-5	-9	-18
35°	-37	-29	-14	-7	-4	-5	-9	-17
40°	-36	-28	-14	-7	-4	-5	-8	-16
45°	-35	-27	-14	-7	-4	-5	-8	-15

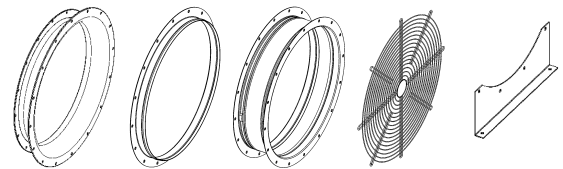

Accessories : see pages 100-102

Design	Pitch Angle	Type (G finish)	Part N°	Type (H finish)	Part N°	L1(mm)	L(mm)	Weight (kg)
K	25°	FV71V-8DK.B7.25.G	150505	FV71V-8DK.B7.25.H	150506	365	280	36
	30°	FV71V-8DK.B7.30.G	150509	FV71V-8DK.B7.30.H	150510	365	280	37
	35°	FV71V-8DK.C7.35.G	150513	FV71V-8DK.C7.35.H	150514	413	280	38
	40°	FV71V-8DK.C7.40.G	150517	FV71V-8DK.C7.40.H	150518	413	280	38
	45°	FV71V-8DK.D7.45.G	150521	FV71V-8DK.D7.45.H	150522	413	280	40
F	25°	FV71V-8DF.B7.25.G	150507	FV71V-8DF.B7.25.H	150508	---	500	46
	30°	FV71V-8DF.B7.30.G	150511	FV71V-8DF.B7.30.H	150512	---	500	47
	35°	FV71V-8DF.C7.35.G	150515	FV71V-8DF.C7.35.H	150516	---	500	48
	40°	FV71V-8DF.C7.40.G	150519	FV71V-8DF.C7.40.H	150520	---	500	48
	45°	FV71V-8DF.D7.45.G	150523	FV71V-8DF.D7.45.H	150524	---	500	50

FV80V-4D

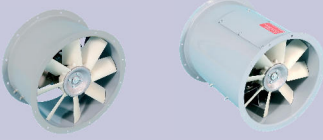

50Hz Motor	U	I	P ₂	n	
	V	A	kW	min ⁻¹	
25°	100 L	400	4,85	2,2	1425
30°	100 L	400	6,2	3	1425
35°	112 M	400	8,2	4	1435
40°	132 S	400	11,2	5,5	1450
45°	132 M	400	15	7,5	1450

Standard Temperature Range : -30°C / +50°C

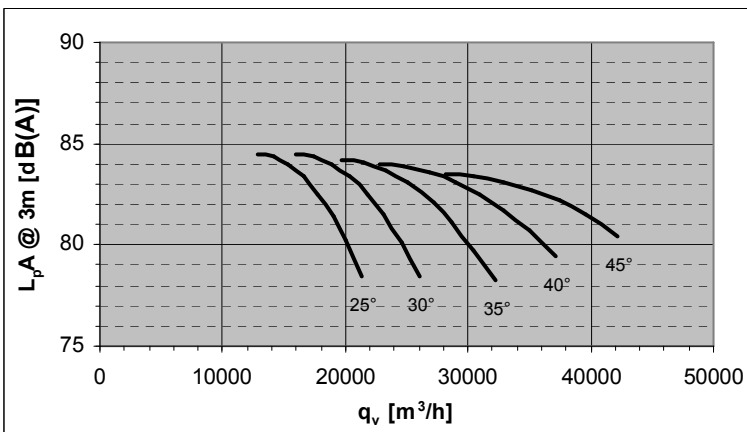
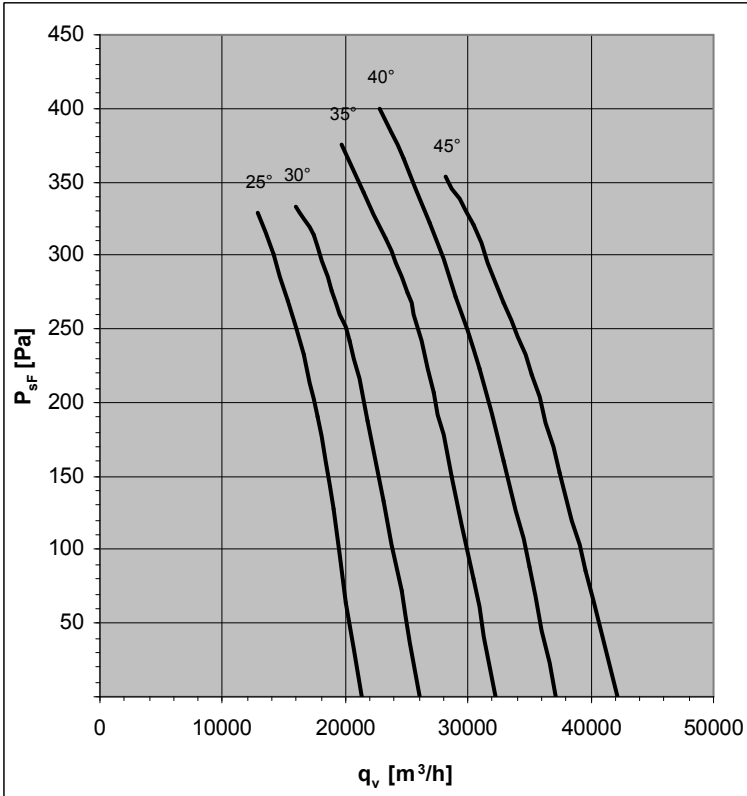

Design K

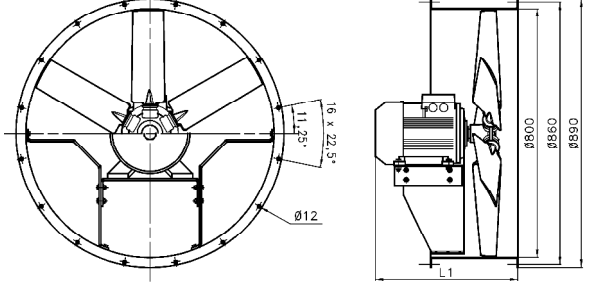

Design F

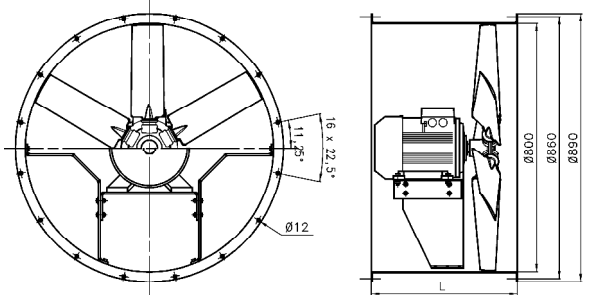

Pitch Angle	Relative spectrum							
	63	125	250	500	1000	2000	4000	8000
25°	-48	-38	-17	-8	-4	-7	-12	-23
30°	-47	-37	-17	-8	-4	-6	-12	-22
35°	-45	-36	-17	-8	-4	-6	-11	-21
40°	-45	-35	-17	-8	-4	-6	-10	-20
45°	-44	-34	-18	-9	-4	-6	-9	-19

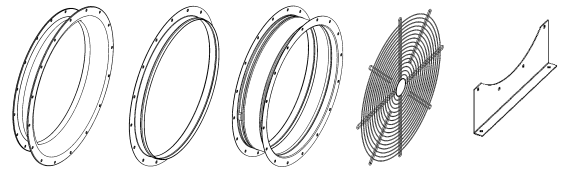

Accessories : see pages 100-102

Design	Pitch Angle	Type (G finish)	Part N°	Type (H finish)	Part N°	L1(mm)	L(mm)	Weight (kg)
K	25°	FV80V-4DK.E7.25.G	150533	FV80V-4DK.E7.25.H	150534	485	280	53
	30°	FV80V-4DK.E7.30.G	150537	FV80V-4DK.E7.30.H	150538	485	280	57
	35°	FV80V-4DK.F7.35.G	150541	FV80V-4DK.F7.35.H	150542	482	400	74
	40°	FV80V-4DK.G7.40.G	150545	FV80V-4DK.G7.40.H	150546	560	400	85
	45°	FV80V-4DK.H7.45.G	150549	FV80V-4DK.H7.45.H	150550	560	400	91
F	25°	FV80V-4DF.E7.25.G	150535	FV80V-4DF.E7.25.H	150536	---	500	65
	30°	FV80V-4DF.E7.30.G	150539	FV80V-4DF.E7.30.H	150540	---	500	69
	35°	FV80V-4DF.F7.35.G	150543	FV80V-4DF.F7.35.H	150544	---	500	80
	40°	FV80V-4DF.G7.40.G	150547	FV80V-4DF.G7.40.H	150548	---	700	102
	45°	FV80V-4DF.H7.45.G	150551	FV80V-4DF.H7.45.H	150552	---	700	108

FV80V-6D



50Hz Motor	U	I	P ₂	n	
	V	A	kW	min ⁻¹	
25°	80 M	400	1,6	0,55	910
30°	90 S	400	2,05	0,75	915
35°	90 L	400	2,85	1,1	915
40°	100 L	400	3,8	1,5	940
45°	112 M	400	5,3	2,2	930

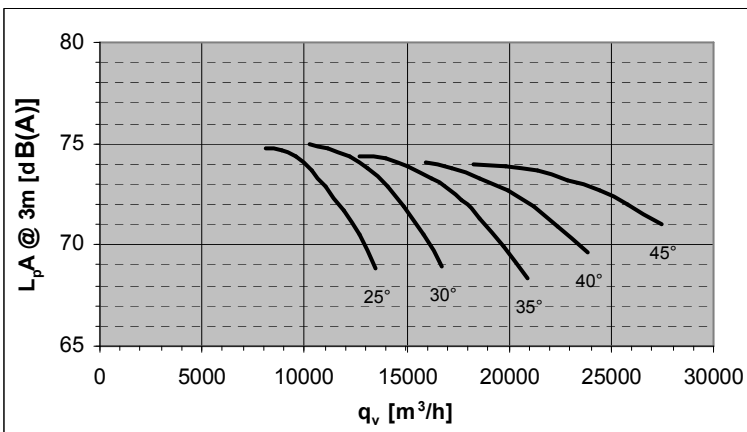
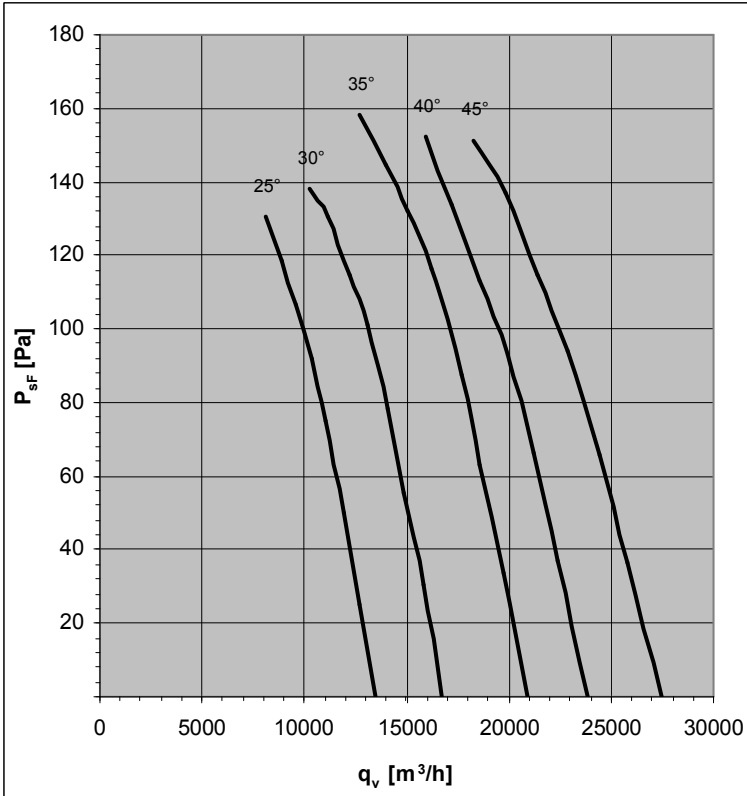

Design K

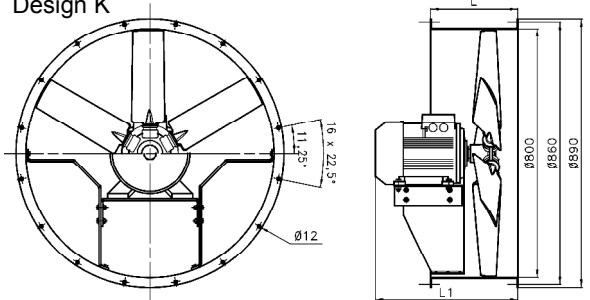

Design F

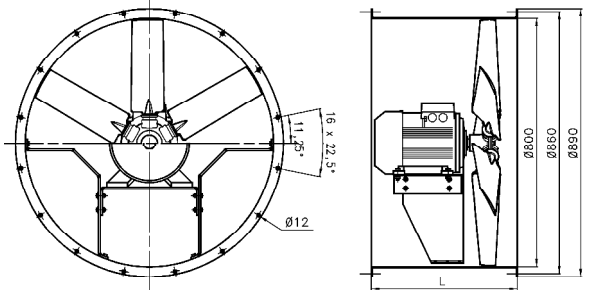

Pitch Angle	Relative spectrum							
	63	125	250	500	1000	2000	4000	8000
25°	-43	-34	-15	-7	-4	-6	-11	-21
30°	-42	-33	-15	-7	-4	-6	-10	-20
35°	-41	-32	-15	-7	-4	-5	-10	-19
40°	-40	-31	-16	-8	-4	-5	-9	-18
45°	-40	-31	-16	-8	-4	-5	-9	-17

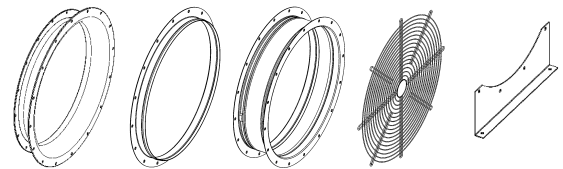

Accessories : see pages 100-102

Design	Pitch Angle	Type (G finish)	Part N°	Type (H finish)	Part N°	L1(mm)	L(mm)	Weight (kg)
K	25°	FV80V-6DK.B7.25.G	150553	FV80V-6DK.B7.25.H	150554	365	280	45
	30°	FV80V-6DK.C7.30.G	150557	FV80V-6DK.C7.30.H	150558	413	280	48
	35°	FV80V-6DK.D7.35.G	150561	FV80V-6DK.D7.35.H	150562	413	280	51
	40°	FV80V-6DK.E7.40.G	150565	FV80V-6DK.E7.40.H	150566	485	280	54
	45°	FV80V-6DK.F7.45.G	150569	FV80V-6DK.F7.45.H	150570	482	400	72
F	25°	FV80V-6DF.B7.25.G	150555	FV80V-6DF.B7.25.H	150556	---	500	57
	30°	FV80V-6DF.C7.30.G	150559	FV80V-6DF.C7.30.H	150560	---	500	60
	35°	FV80V-6DF.D7.35.G	150563	FV80V-6DF.D7.35.H	150564	---	500	63
	40°	FV80V-6DF.E7.40.G	150567	FV80V-6DF.E7.40.H	150568	---	500	66
	45°	FV80V-6DF.F7.45.G	150571	FV80V-6DF.F7.45.H	150572	---	500	78

FV80V-8D

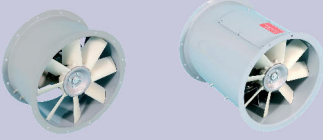

50Hz Motor	U V	I A	P ₂ kW	n min ⁻¹	
25°	80 M	400	1,02	0,25	685
30°	90 S	400	1,14	0,37	675
35°	90 L	400	1,58	0,55	675
40°	90 L	400	1,58	0,55	675
45°	100 L	400	2,45	0,75	695

Standard Temperature Range : -30°C / +50°C

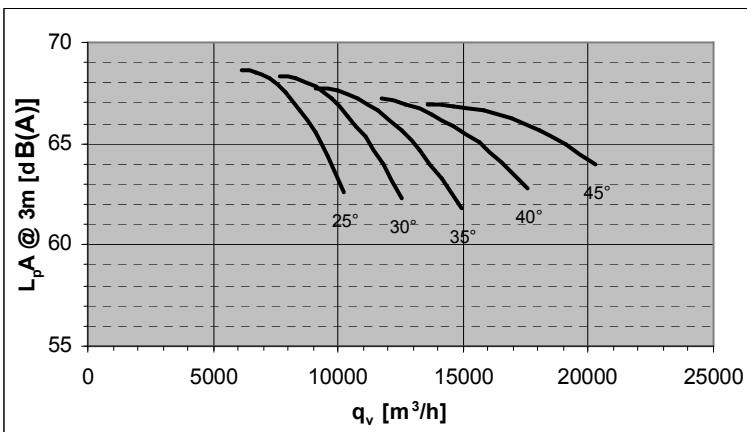
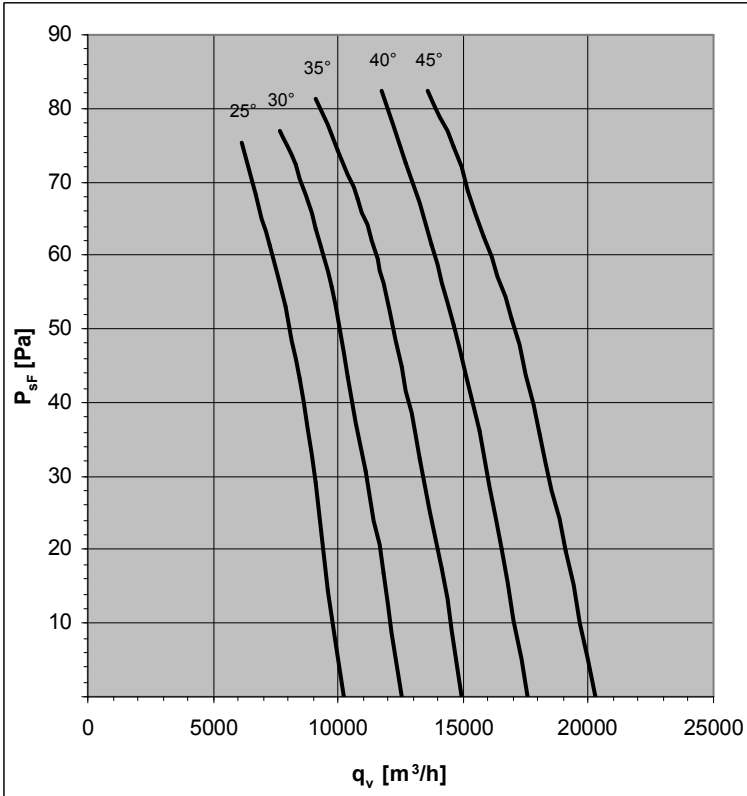

Design K

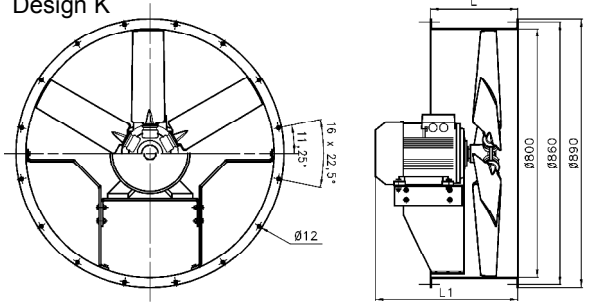

Design F

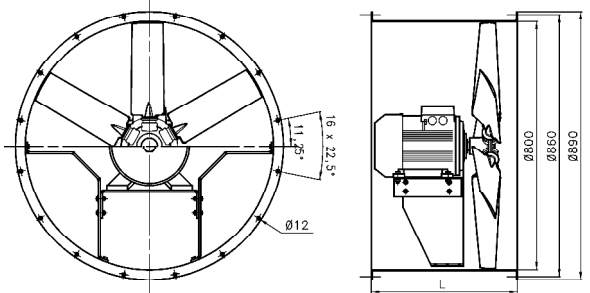

Pitch Angle	Relative spectrum							
	63	125	250	500	1000	2000	4000	8000
25°	-40	-32	-14	-7	-4	-5	-10	-19
30°	-39	-31	-14	-7	-4	-5	-10	-18
35°	-38	-29	-14	-7	-4	-5	-9	-17
40°	-37	-29	-14	-7	-4	-5	-8	-16
45°	-37	-28	-15	-7	-4	-5	-8	-16

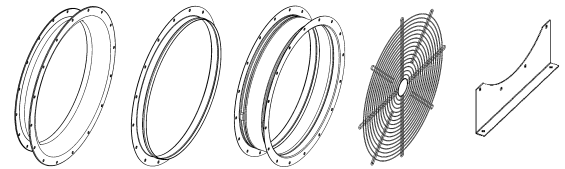

Accessories : see pages 100-102

Design	Pitch Angle	Type (G finish)	Part N°	Type (H finish)	Part N°	L1(mm)	L(mm)	Weight (kg)
K	25°	FV80V-8DK.B7.25.G	150573	FV80V-8DK.B7.25.H	150574	365	280	45
	30°	FV80V-8DK.C7.30.G	150577	FV80V-8DK.C7.30.H	150578	413	280	46
	35°	FV80V-8DK.D7.35.G	150581	FV80V-8DK.D7.35.H	150582	413	280	48
	40°	FV80V-8DK.D7.40.G	150585	FV80V-8DK.D7.40.H	150586	413	280	48
	45°	FV80V-8DK.E7.45.G	150589	FV80V-8DK.E7.45.H	150590	485	280	52
F	25°	FV80V-8DF.B7.25.G	150575	FV80V-8DF.B7.25.H	150576	---	500	57
	30°	FV80V-8DF.C7.30.G	150579	FV80V-8DF.C7.30.H	150580	---	500	58
	35°	FV80V-8DF.D7.35.G	150583	FV80V-8DF.D7.35.H	150584	---	500	60
	40°	FV80V-8DF.D7.40.G	150587	FV80V-8DF.D7.40.H	150588	---	500	60
	45°	FV80V-8DF.E7.45.G	150591	FV80V-8DF.E7.45.H	150592	---	500	64

FV90V-4D

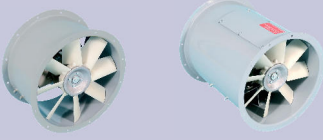

50Hz Motor	U	I	P ₂	n	
	V	A	kW	min ⁻¹	
25°	100 L	400	6,2	3	1425
30°	112 M	400	8,2	4	1435
35°	132 S	400	11,2	5,5	1450
40°	132 M	400	15	7,5	1450
45°	160 M	400	22	11	1460

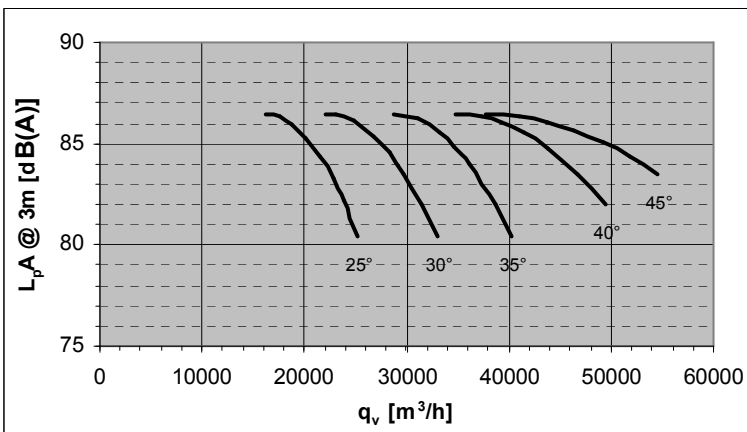
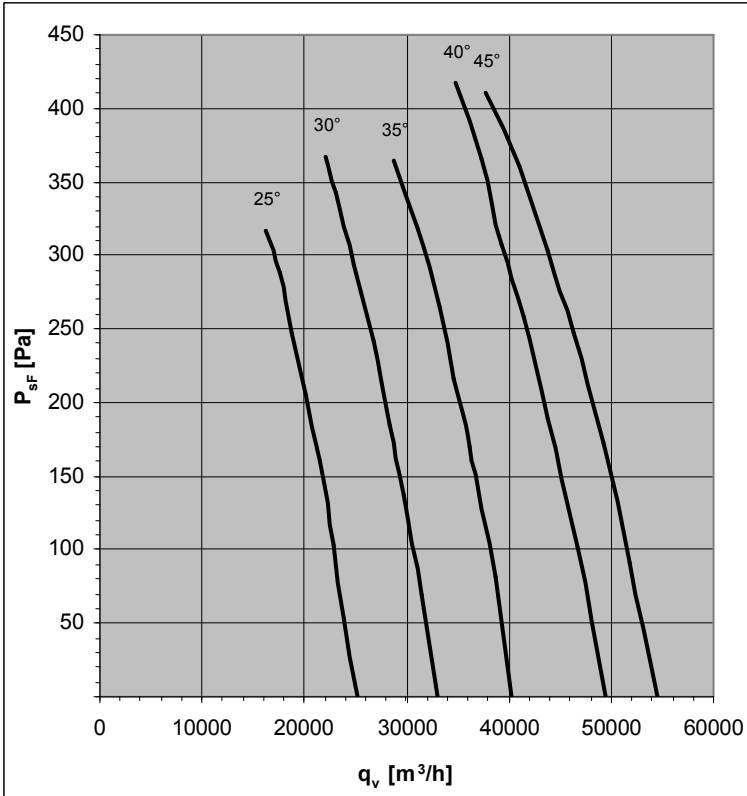

Design K

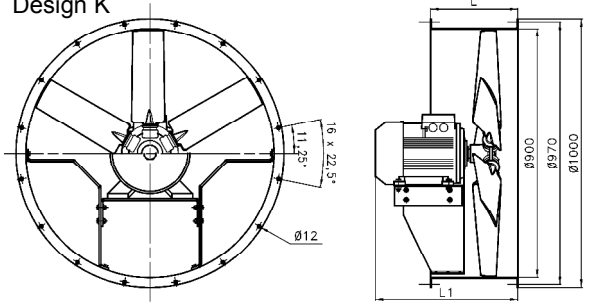

Design F

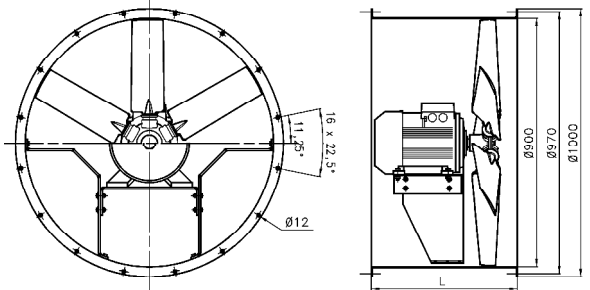

Pitch Angle	Relative spectrum							
	63	125	250	500	1000	2000	4000	8000
25°	-49	-39	-17	-8	-5	-7	-13	-24
30°	-48	-38	-17	-8	-5	-6	-12	-22
35°	-47	-36	-17	-8	-5	-6	-11	-21
40°	-46	-36	-18	-9	-5	-6	-10	-20
45°	-45	-35	-18	-9	-5	-6	-10	-19

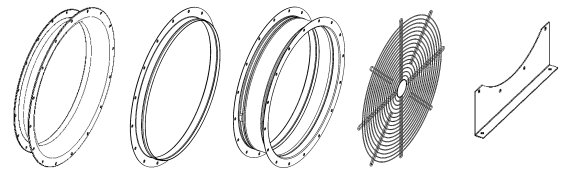

Accessories : see pages 100-102

Design	Pitch Angle	Type (G finish)	Part N°	Type (H finish)	Part N°	L1(mm)	L(mm)	Weight (kg)
K	25°	FV90V-4DK.E7.25.G	150613	FV90V-4DK.E7.25.H	150614	485	280	63
	30°	FV90V-4DK.F7.30.G	150617	FV90V-4DK.F7.30.H	150618	482	400	81
	35°	FV90V-4DK.G7.35.G	150621	FV90V-4DK.G7.35.H	150622	560	400	92
	40°	FV90V-4DK.H7.40.G	150625	FV90V-4DK.H7.40.H	150626	560	400	98
	45°	FV90V-4DK.I7.45.G	150629	FV90V-4DK.I7.45.H	150630	695	400	121
F	25°	FV90V-4DF.E7.25.G	150615	FV90V-4DF.E7.25.H	150616	---	500	77
	30°	FV90V-4DF.F7.30.G	150619	FV90V-4DF.F7.30.H	150620	---	500	87
	35°	FV90V-4DF.G7.35.G	150623	FV90V-4DF.G7.35.H	150624	---	700	110
	40°	FV90V-4DF.H7.40.G	150627	FV90V-4DF.H7.40.H	150628	---	700	116
	45°	FV90V-4DF.I7.45.G	150631	FV90V-4DF.I7.45.H	150632	---	700	140

FV90V-6D



50Hz Motor	U	I	P ₂	n	
	V	A	kW	min ⁻¹	
25°	90 S	400	2,05	0,75	915
30°	90 L	400	2,85	1,1	915
35°	100 L	400	3,8	1,5	940
40°	112 M	400	5,3	2,2	930
45°	132 S	400	7,2	3	955

Standard Temperature Range : -30°C / +50°C

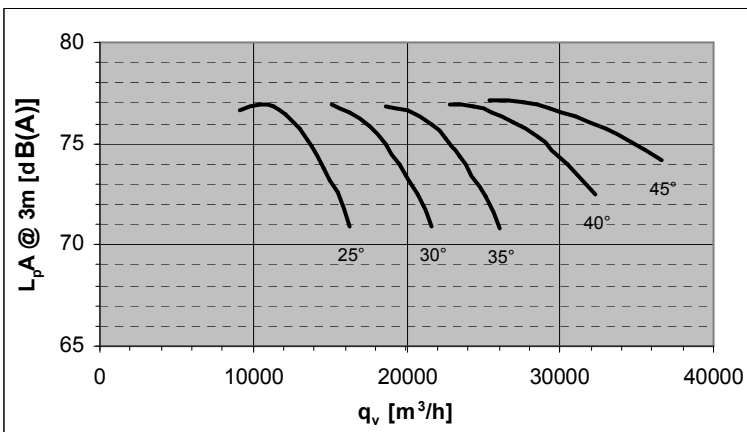
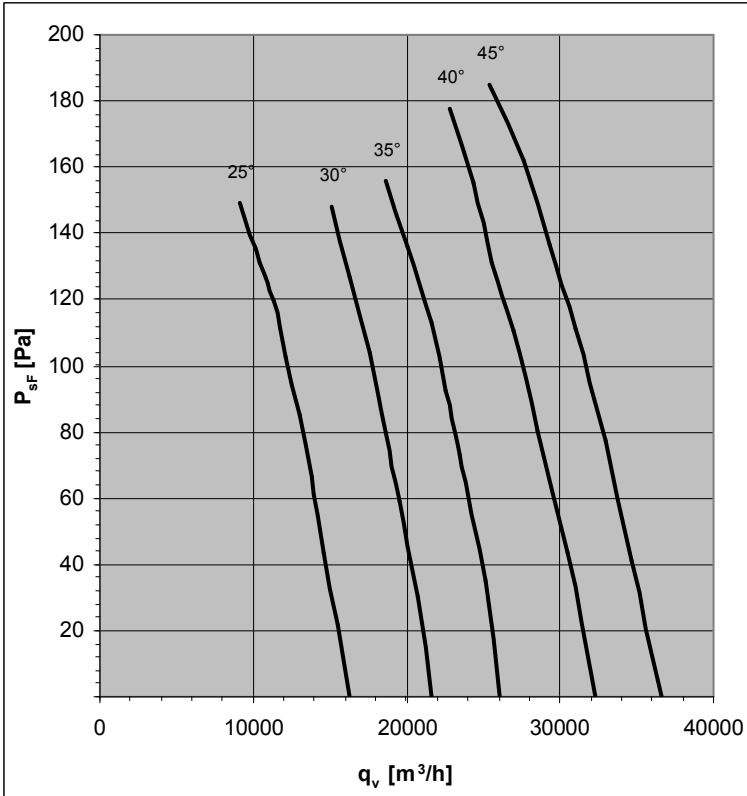

Design K

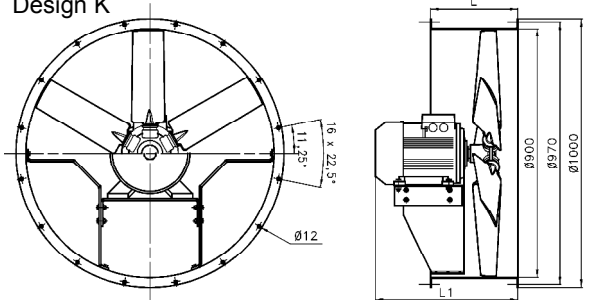

Design F

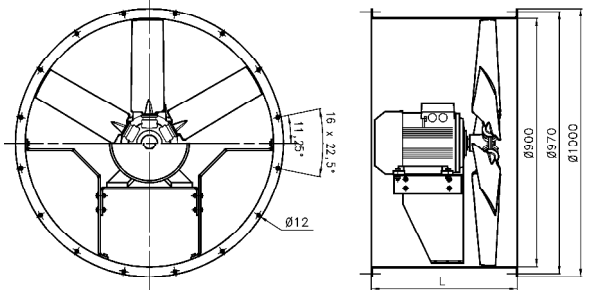

Pitch Angle	Relative spectrum							
	63	125	250	500	1000	2000	4000	8000
25°	-44	-35	-15	-8	-4	-6	-11	-21
30°	-43	-34	-15	-8	-4	-6	-11	-20
35°	-42	-33	-16	-8	-4	-6	-10	-19
40°	-42	-32	-16	-8	-4	-6	-9	-18
45°	-41	-32	-16	-8	-4	-5	-9	-18

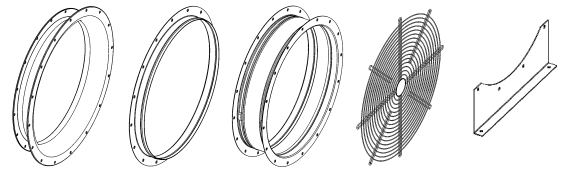

Accessories : see pages 100-102

Design	Pitch Angle	Type (G finish)	Part N°	Type (H finish)	Part N°	L1(mm)	L(mm)	Weight (kg)
K	25°	FV90V-6DK.C7.25.G	150633	FV90V-6DK.C7.25.H	150634	413	280	54
	30°	FV90V-6DK.D7.30.G	150637	FV90V-6DK.D7.30.H	150638	413	280	57
	35°	FV90V-6DK.E7.35.G	150641	FV90V-6DK.E7.35.H	150642	485	280	60
	40°	FV90V-6DK.F7.40.G	150645	FV90V-6DK.F7.40.H	150646	482	400	79
	45°	FV90V-6DK.G7.45.G	150649	FV90V-6DK.G7.45.H	150650	560	400	88
F	25°	FV90V-6DF.C7.25.G	150635	FV90V-6DF.C7.25.H	150636	---	500	68
	30°	FV90V-6DF.D7.30.G	150639	FV90V-6DF.D7.30.H	150640	---	500	71
	35°	FV90V-6DF.E7.35.G	150643	FV90V-6DF.E7.35.H	150644	---	500	74
	40°	FV90V-6DF.F7.40.G	150647	FV90V-6DF.F7.40.H	150648	---	500	85
	45°	FV90V-6DF.G7.45.G	150651	FV90V-6DF.G7.45.H	150652	---	700	106

FV90V-8D

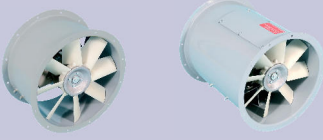

50Hz Motor	U	I	P ₂	n	
	V	A	kW	min ⁻¹	
25°	90 S	400	1,14	0,37	675
30°	90 L	400	1,58	0,55	675
35°	100 L	400	2,45	0,75	695
40°	100 L	400	2,45	0,75	695
45°	100 L	400	3,5	1,1	695

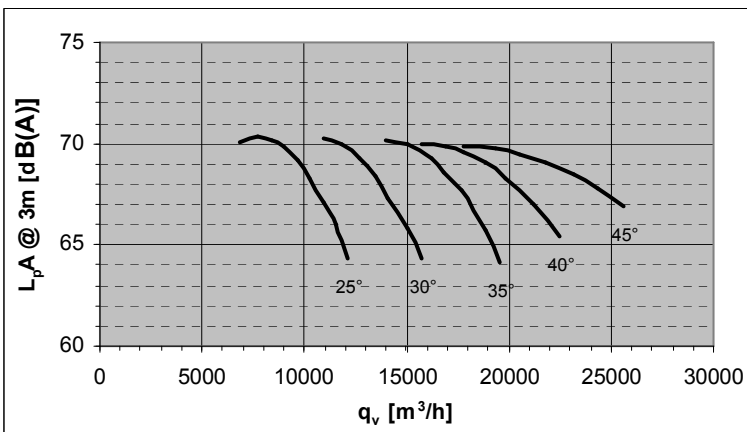
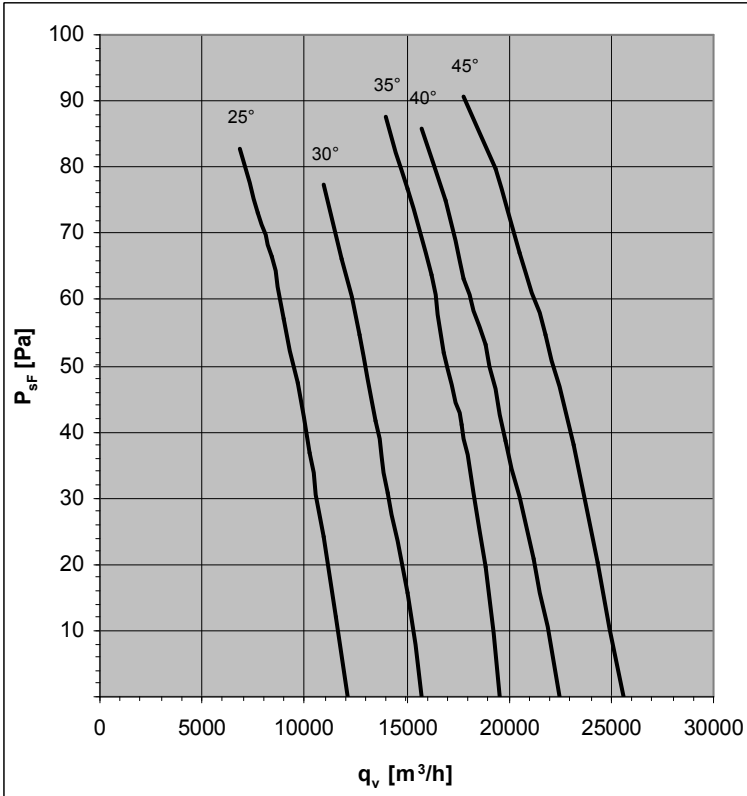

Design K

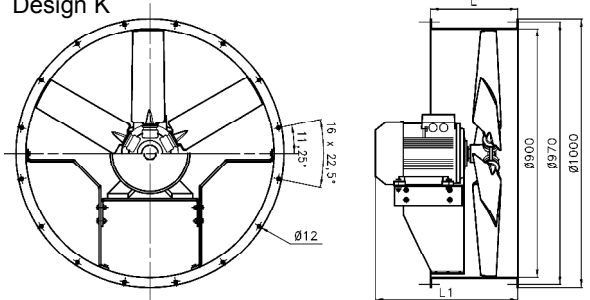

Design F

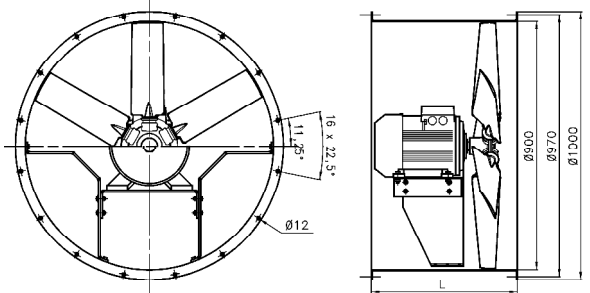

Pitch Angle	Relative spectrum							
	63	125	250	500	1000	2000	4000	8000
25°	-41	-32	-14	-7	-4	-6	-10	-20
30°	-40	-31	-14	-7	-4	-5	-10	-19
35°	-39	-30	-14	-7	-4	-5	-9	-18
40°	-38	-30	-15	-7	-4	-5	-9	-17
45°	-38	-29	-15	-7	-4	-5	-8	-16

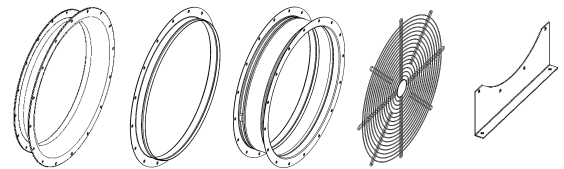

Accessories : see pages 100-102

Design	Pitch Angle	Type (G finish)	Part N°	Type (H finish)	Part N°	L1(mm)	L(mm)	Weight (kg)
K	25°	FV90V-8DK.C7.25.G	150653	FV90V-8DK.C7.25.H	150654	413	280	52
	30°	FV90V-8DK.D7.30.G	150657	FV90V-8DK.D7.30.H	150658	413	280	54
	35°	FV90V-8DK.E7.35.G	150661	FV90V-8DK.E7.35.H	150662	485	280	58
	40°	FV90V-8DK.E7.40.G	150665	FV90V-8DK.E7.40.H	150666	485	280	58
	45°	FV90V-8DK.E7.45.G	150669	FV90V-8DK.E7.45.H	150670	485	280	63
F	25°	FV90V-8DF.C7.25.G	150655	FV90V-8DF.C7.25.H	150656	---	500	66
	30°	FV90V-8DF.D7.30.G	150659	FV90V-8DF.D7.30.H	150660	---	500	68
	35°	FV90V-8DF.E7.35.G	150663	FV90V-8DF.E7.35.H	150664	---	500	72
	40°	FV90V-8DF.E7.40.G	150667	FV90V-8DF.E7.40.H	150668	---	500	72
	45°	FV90V-8DF.E7.45.G	150671	FV90V-8DF.E7.45.H	150672	---	500	77

FV10V-4D

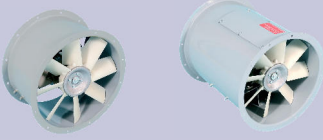

50Hz Motor	U	I	P ₂	n	
	V	A	kW	min ⁻¹	
30°	132 M	400	15	7,5	1450
35°	160 M	400	22	11	1460
40°	160 L	400	29,5	15	1460
45°	180 M	400	35	18,5	1465
50°	200 L	400	56	30	1465

Standard Temperature Range : -30°C / +50°C

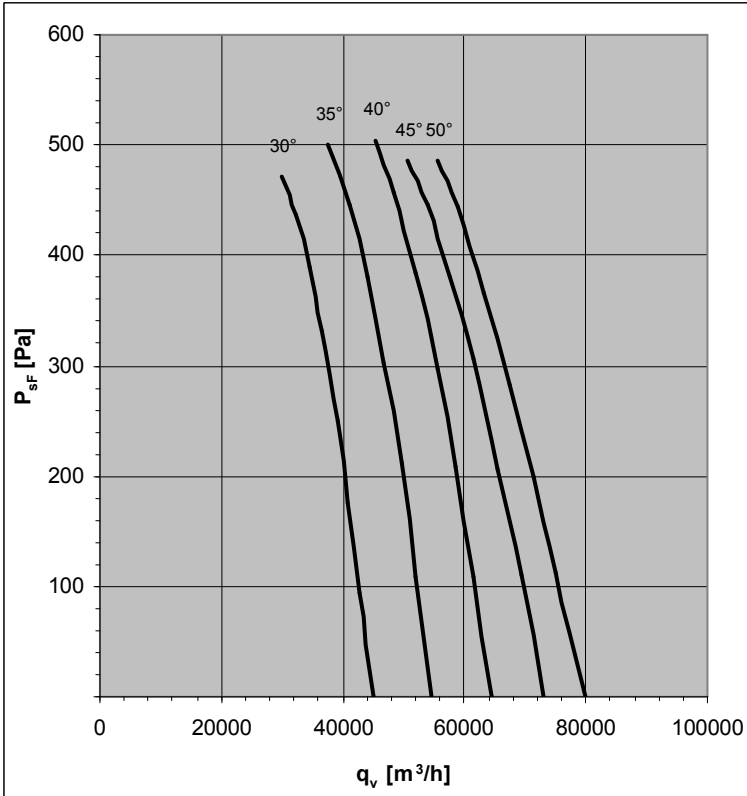

Design K

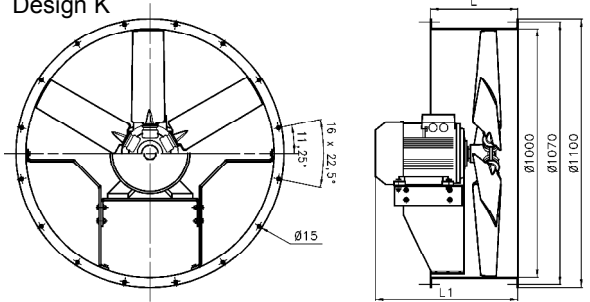

Design F

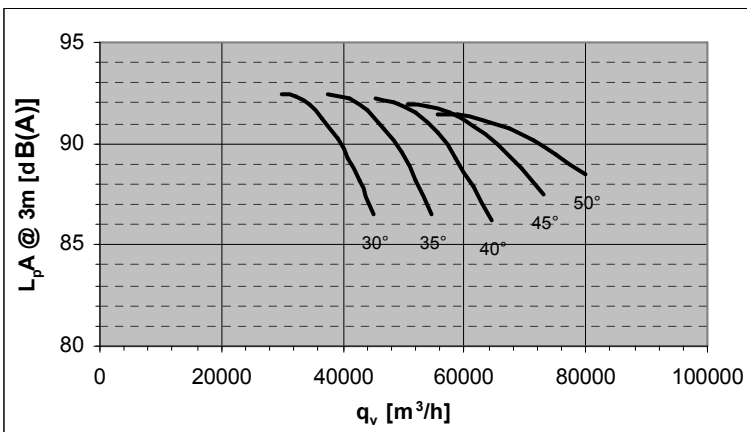
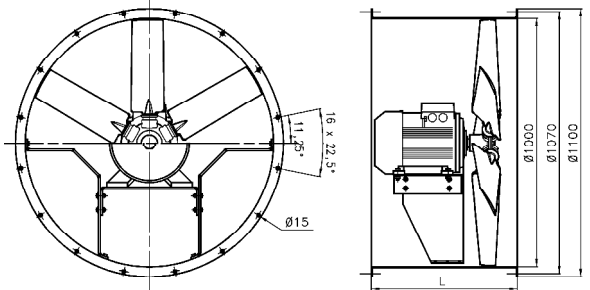

Pitch Angle	Relative spectrum							
	63	125	250	500	1000	2000	4000	8000
30°	-52	-41	-18	-9	-5	-7	-13	-25
35°	-51	-40	-18	-9	-5	-7	-12	-24
40°	-49	-39	-18	-9	-5	-7	-12	-22
45°	-49	-38	-19	-9	-5	-6	-11	-21
50°	-48	-37	-19	-9	-5	-6	-10	-20

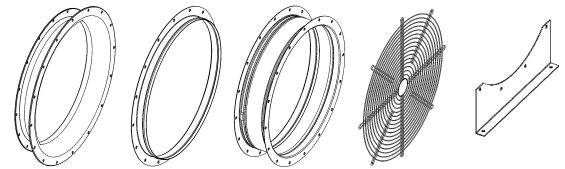

Accessories : see pages 100-102

Design	Pitch Angle	Type (G finish)	Part N°	Type (H finish)	Part N°	L1(mm)	L(mm)	Weight (kg)
K	30°	FV10V-4DK.H7.30.G	150693	FV10V-4DK.H7.30.H	150694	560	400	107
	35°	FV10V-4DK.I7.35.G	150697	FV10V-4DK.I7.35.H	150698	695	400	133
	40°	FV10V-4DK.K7.40.G	150701	FV10V-4DK.K7.40.H	150702	695	400	144
	45°	FV10V-4DK.L7.45.G	150705	FV10V-4DK.L7.45.H	150706	756	450	237
	50°	FV10V-4DK.N7.50.G	150709	FV10V-4DK.N7.50.H	150710	850	450	302
F	30°	FV10V-4DF.H7.30.G	150695	FV10V-4DF.H7.30.H	150696	---	700	130
	35°	FV10V-4DF.I7.35.G	150699	FV10V-4DF.I7.35.H	150700	---	700	155
	40°	FV10V-4DF.K7.40.G	150703	FV10V-4DF.K7.40.H	150704	---	700	166
	45°	FV10V-4DF.L7.45.G	150707	FV10V-4DF.L7.45.H	150708	---	860	268
	50°	FV10V-4DF.N7.50.G	150711	FV10V-4DF.N7.50.H	150712	---	860	333

FV10V-6D

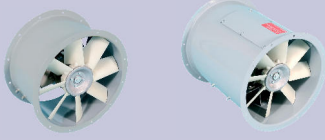

50Hz Motor	U	I	P ₂	n	
	V	A	kW	min ⁻¹	
30°	112 M	400	5,3	2,2	930
35°	132 S	400	7,2	3	955
40°	132 M	400	9,2	4	950
45°	132 M	400	12,4	5,5	950
50°	160 M	400	17,2	7,5	970

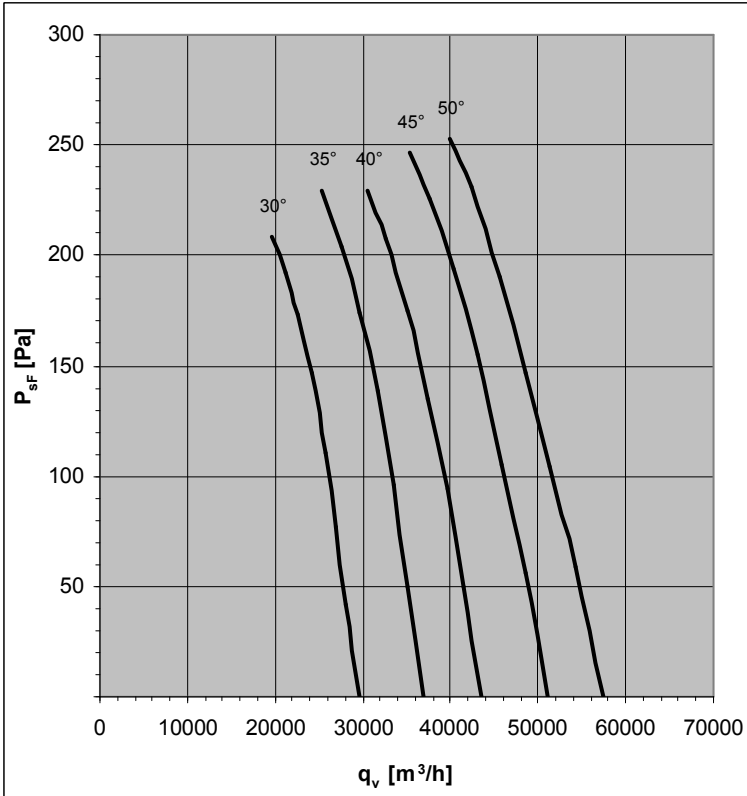

Design K

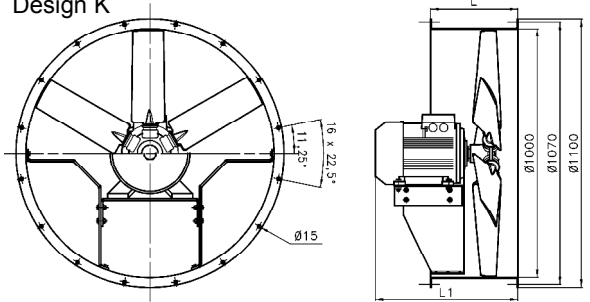

Design F

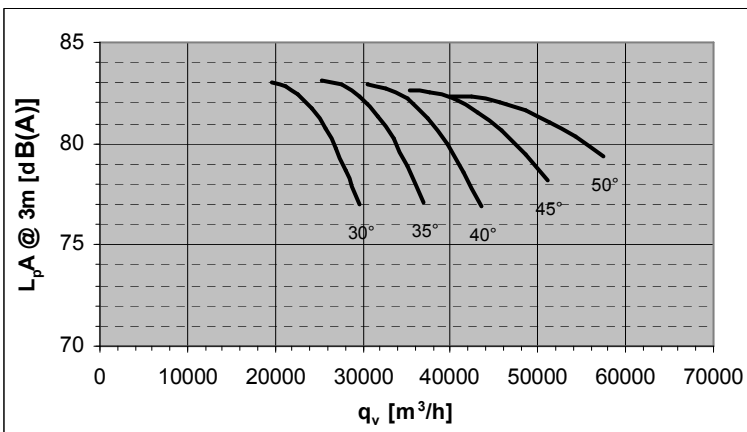
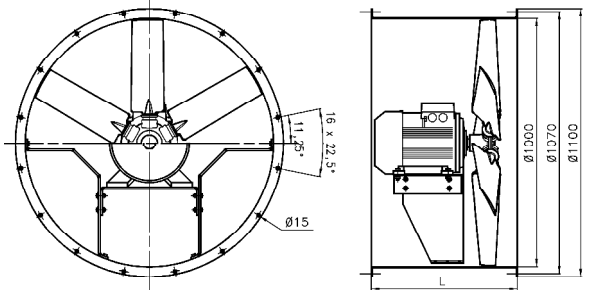

Pitch Angle	Relative spectrum							
	63	125	250	500	1000	2000	4000	8000
30°	-47	-37	-16	-8	-4	-6	-12	-23
35°	-46	-36	-17	-8	-4	-6	-11	-22
40°	-45	-35	-17	-8	-4	-6	-11	-20
45°	-44	-34	-17	-8	-4	-6	-10	-19
50°	-44	-34	-17	-9	-4	-6	-9	-19

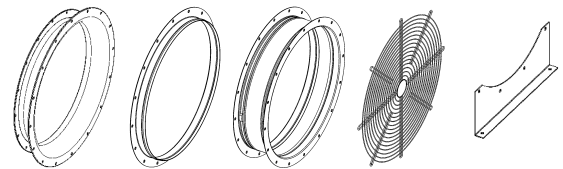

Accessories : see pages 100-102

Design	Pitch Angle	Type (G finish)	Part N°	Type (H finish)	Part N°	L1(mm)	L(mm)	Weight (kg)
K	30°	FV10V-6DK.F7.30.G	150713	FV10V-6DK.F7.30.H	150714	482	400	88
	35°	FV10V-6DK.G7.35.G	150717	FV10V-6DK.G7.35.H	150718	560	400	97
	40°	FV10V-6DK.H7.40.G	150721	FV10V-6DK.H7.40.H	150722	560	400	102
	45°	FV10V-6DK.H7.45.G	150725	FV10V-6DK.H7.45.H	150726	560	400	111
	50°	FV10V-6DK.I7.50.G	150729	FV10V-6DK.I7.50.H	150730	695	400	143
F	30°	FV10V-6DF.F7.30.G	150715	FV10V-6DF.F7.30.H	150716	---	700	111
	35°	FV10V-6DF.G7.35.G	150719	FV10V-6DF.G7.35.H	150720	---	700	120
	40°	FV10V-6DF.H7.40.G	150723	FV10V-6DF.H7.40.H	150724	---	700	125
	45°	FV10V-6DF.H7.45.G	150727	FV10V-6DF.H7.45.H	150728	---	700	134
	50°	FV10V-6DF.I7.50.G	150731	FV10V-6DF.I7.50.H	150732	---	700	165

FV10V-8D

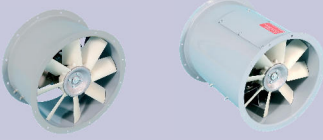

50Hz Motor	U	I	P ₂	n
	V	A	kW	min ⁻¹
30°	112 M	4,00	1,5	675
35°	112 M	4,00	1,5	675
40°	132 S	6,2	2,2	720
45°	132 S	6,2	2,2	720
50°	132 M	8,5	3	715

Standard Temperature Range : -30°C / +50°C

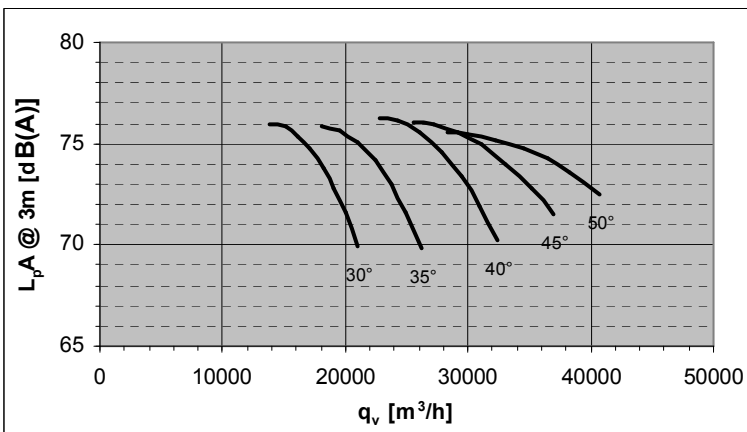
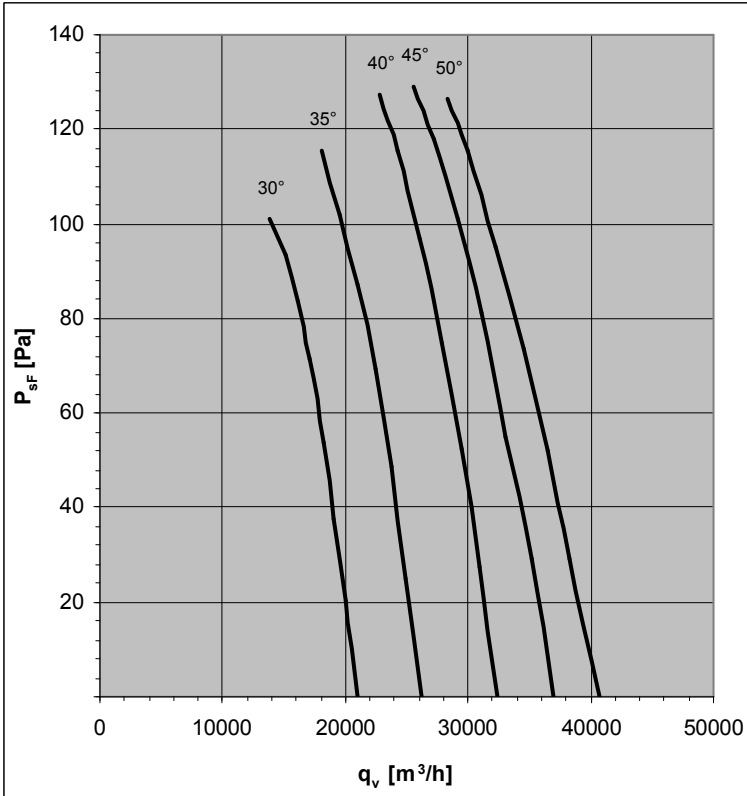

Design K

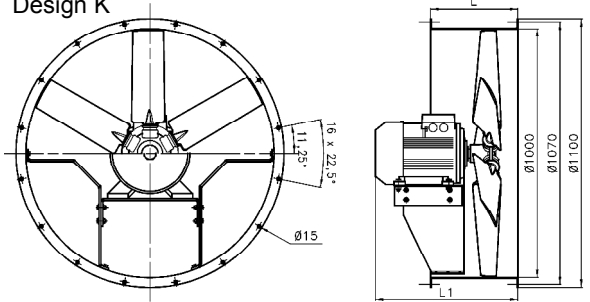

Design F

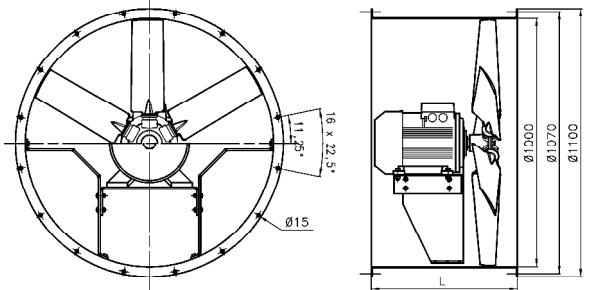

Pitch Angle	Relative spectrum							
	63	125	250	500	1000	2000	4000	8000
30°	-44	-35	-15	-7	-4	-6	-11	-21
35°	-43	-34	-15	-7	-4	-6	-10	-20
40°	-42	-33	-15	-8	-4	-6	-10	-19
45°	-41	-32	-16	-8	-4	-5	-9	-18
50°	-41	-31	-16	-8	-4	-5	-9	-17

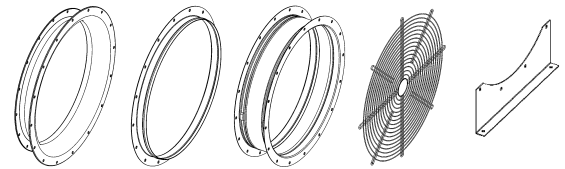

Accessories : see pages 100-102

Design	Pitch Angle	Type (G finish)	Part N°	Type (H finish)	Part N°	L1(mm)	L(mm)	Weight (kg)
K	30°	FV10V-8DK.F7.30.G	150733	FV10V-8DK.F7.30.H	150734	482	400	88
	35°	FV10V-8DK.F7.35.G	150737	FV10V-8DK.F7.35.H	150738	482	400	88
	40°	FV10V-8DK.G7.40.G	150741	FV10V-8DK.G7.40.H	150742	560	400	100
	45°	FV10V-8DK.G7.45.G	150745	FV10V-8DK.G7.45.H	150746	560	400	100
	50°	FV10V-8DK.H7.50.G	150749	FV10V-8DK.H7.50.H	150750	560	400	107
F	30°	FV10V-8DF.F7.30.G	150735	FV10V-8DF.F7.30.H	150736	---	700	111
	35°	FV10V-8DF.F7.35.G	150739	FV10V-8DF.F7.35.H	150740	---	700	111
	40°	FV10V-8DF.G7.40.G	150743	FV10V-8DF.G7.40.H	150744	---	700	123
	45°	FV10V-8DF.G7.45.G	150747	FV10V-8DF.G7.45.H	150748	---	700	123
	50°	FV10V-8DF.H7.50.G	150751	FV10V-8DF.H7.50.H	150752	---	700	130

FV12V-4D

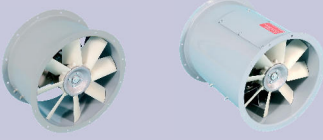

50Hz Motor	U	I	P ₂	n	
	V	A	kW	min ⁻¹	
22°	180 M	400	35	18,5	1465
24°	180 L	400	41,5	22	1465
29°	200 L	400	56	30	1465
32°	225 S	400	68	37	1475
36°	225 M	400	81	45	1475

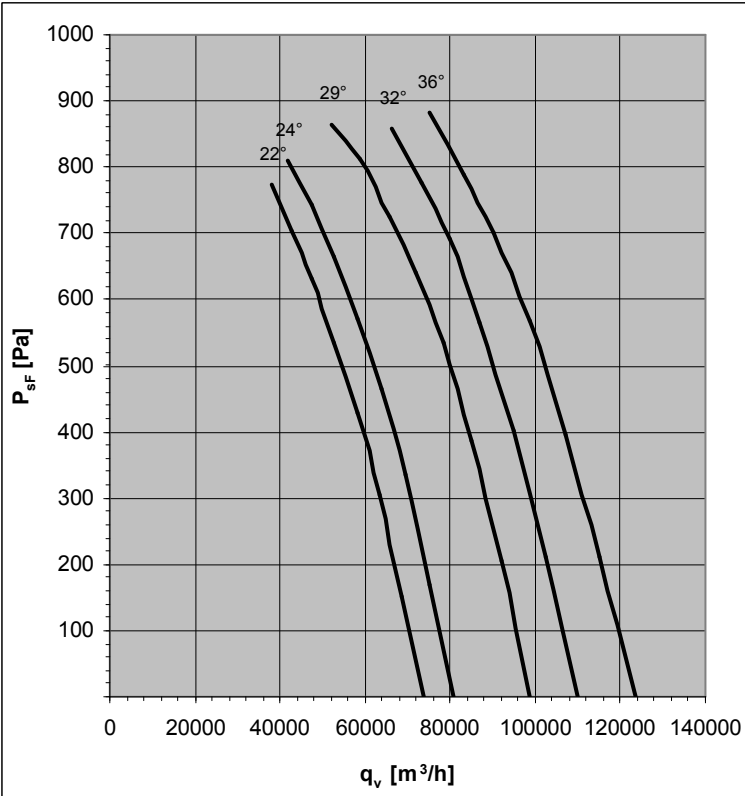

Design K

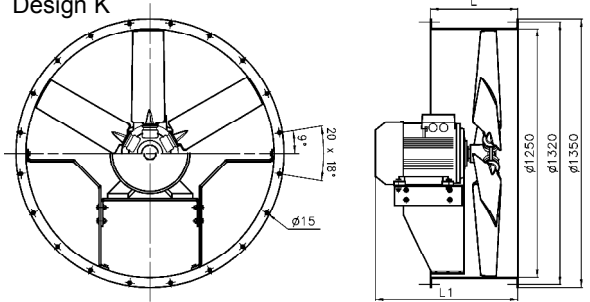

Design F

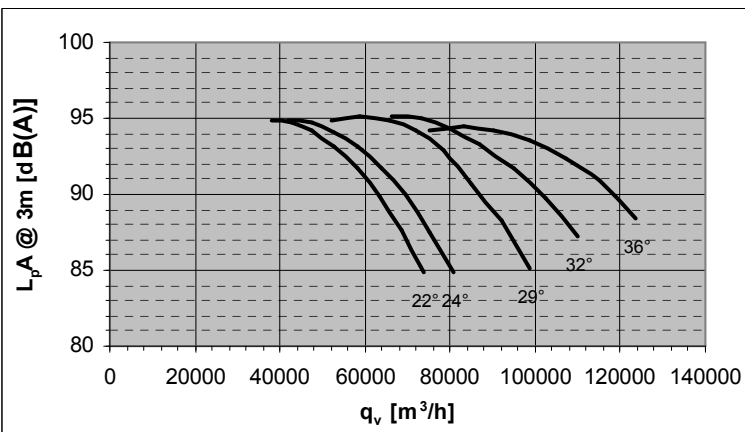
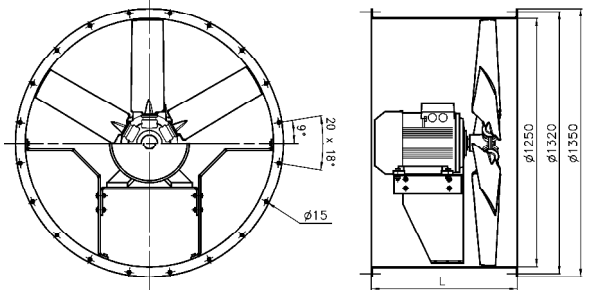

Pitch Angle	Relative spectrum							
	63	125	250	500	1000	2000	4000	8000
22°	-51	-40	-18	-9	-5	-7	-13	-25
24°	-50	-39	-18	-9	-5	-7	-12	-23
29°	-49	-38	-18	-9	-5	-7	-12	-22
32°	-48	-38	-19	-9	-5	-6	-11	-21
36°	-48	-37	-19	-9	-5	-6	-10	-20

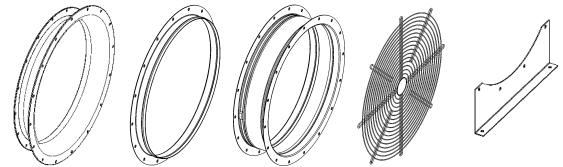

Accessories : see pages 100-102

Design	Pitch Angle	Type (G finish)	Part N°	Type (H finish)	Part N°	L1(mm)	L(mm)	Weight (kg)
K	22°	FV12V-4DK.L7.22.G	150785	FV12V-4DK.L7.22.H	150786	798	500	266
	24°	FV12V-4DK.M7.24.G	150789	FV12V-4DK.M7.24.H	150790	798	500	281
	29°	FV12V-4DK.N7.29.G	150793	FV12V-4DK.N7.29.H	150794	850	500	331
	32°	FV12V-4DK.P7.32.G	150797	FV12V-4DK.P7.32.H	150798	920	500	391
	36°	FV12V-4DK.R7.36.G	150801	FV12V-4DK.R7.36.H	150802	920	500	426
F	22°	FV12V-4DF.L7.22.G	150787	FV12V-4DF.L7.22.H	150788	---	930	306
	24°	FV12V-4DF.M7.24.G	150791	FV12V-4DF.M7.24.H	150792	---	930	321
	29°	FV12V-4DF.N7.29.G	150795	FV12V-4DF.N7.29.H	150796	---	930	371
	32°	FV12V-4DF.P7.32.G	150799	FV12V-4DF.P7.32.H	150800	---	930	431
	36°	FV12V-4DF.R7.36.G	150803	FV12V-4DF.R7.36.H	150804	---	930	466

FV12V-6D

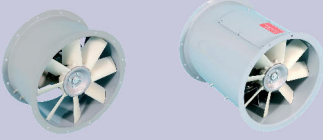

50Hz Motor	U	I	P ₂	n	
	V	A	kW	min ⁻¹	
23°	132 M	400	12,4	5,5	950
27°	160 M	400	17,2	7,5	970
34°	160 L	400	23,5	11	965
39°	180 L	400	29,5	15	965
43°	200 L	400	36,5	18,5	975

Standard Temperature Range : -30°C / +50°C

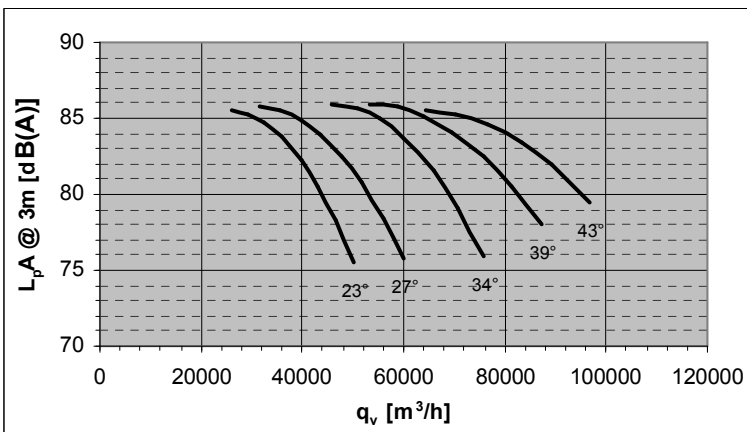
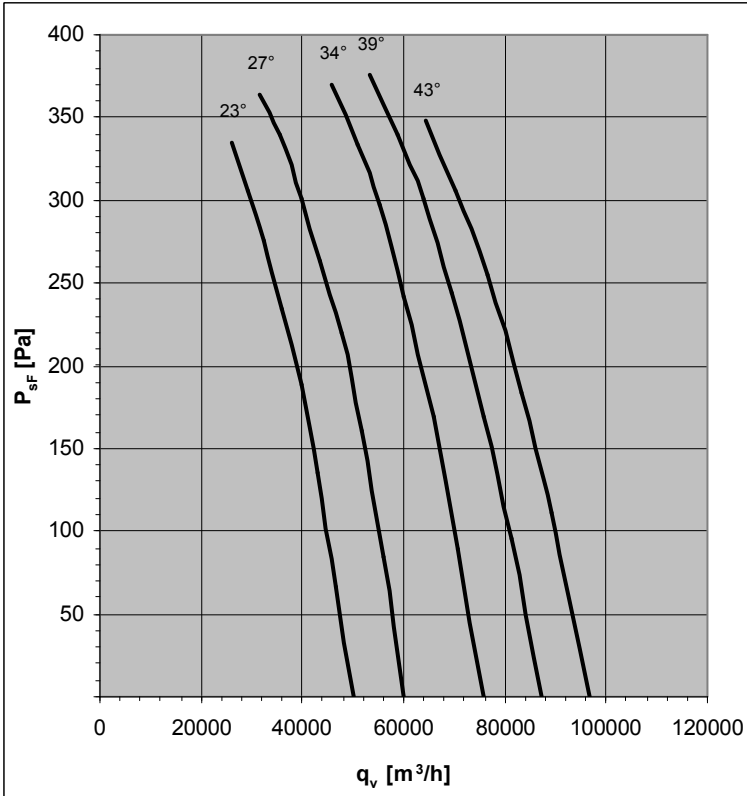

Design K

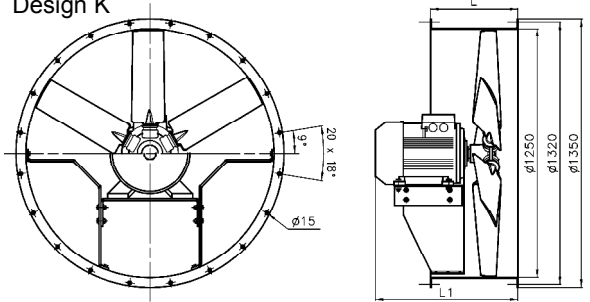

Design F

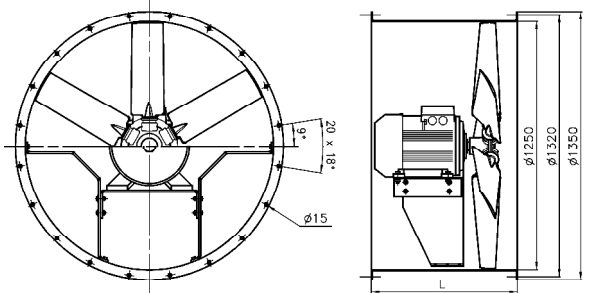

Pitch Angle	Relative spectrum							
	63	125	250	500	1000	2000	4000	8000
23°	-47	-37	-16	-8	-4	-6	-12	-22
27°	-45	-36	-16	-8	-4	-6	-11	-21
34°	-44	-35	-17	-8	-4	-6	-10	-20
39°	-44	-34	-17	-8	-4	-6	-10	-19
43°	-44	-34	-17	-9	-4	-6	-9	-19

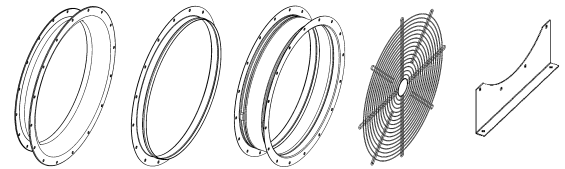

Accessories : see pages 100-102

Design	Pitch Angle	Type (G finish)	Part N°	Type (H finish)	Part N°	L1(mm)	L(mm)	Weight (kg)
K	23°	FV12V-6DK.H7.23.G	150805	FV12V-6DK.H7.23.H	150806	623	500	148
	27°	FV12V-6DK.I7.27.G	150809	FV12V-6DK.I7.27.H	150810	756	500	172
	34°	FV12V-6DK.K7.34.G	150813	FV12V-6DK.K7.34.H	150814	756	500	192
	39°	FV12V-6DK.M7.39.G	150817	FV12V-6DK.M7.39.H	150818	798	500	276
	43°	FV12V-6DK.N7.43.G	150821	FV12V-6DK.N7.43.H	150822	850	500	321
F	23°	FV12V-6DF.H7.23.G	150807	FV12V-6DF.H7.23.H	150808	---	760	171
	27°	FV12V-6DF.I7.27.G	150811	FV12V-6DF.I7.27.H	150812	---	760	195
	34°	FV12V-6DF.K7.34.G	150815	FV12V-6DF.K7.34.H	150816	---	760	215
	39°	FV12V-6DF.M7.39.G	150819	FV12V-6DF.M7.39.H	150820	---	930	316
	43°	FV12V-6DF.N7.43.G	150823	FV12V-6DF.N7.43.H	150824	---	930	361

FV12V-8D

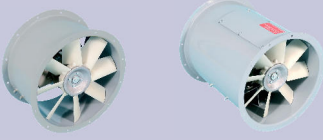

50Hz Motor	U	I	P ₂	n	
	V	A	kW	min ⁻¹	
28°	132 M	400	8,5	3	715
31°	160 M	400	10,4	4	720
38°	160 M	400	13,6	5,5	720
43°	160 L	400	18,6	7,5	715
50°	180 L	400	25	11	725

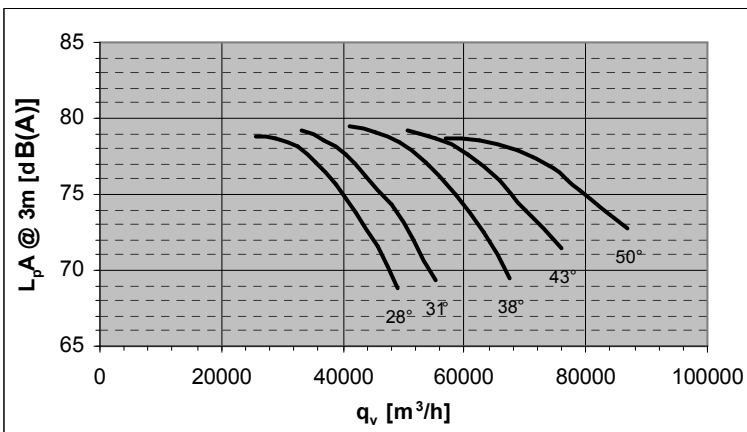
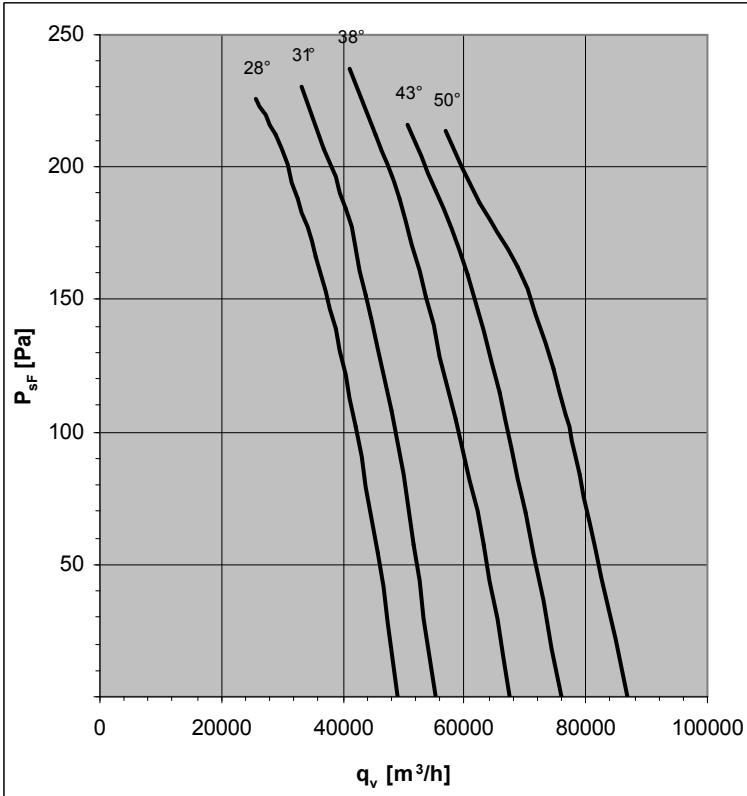

Design K

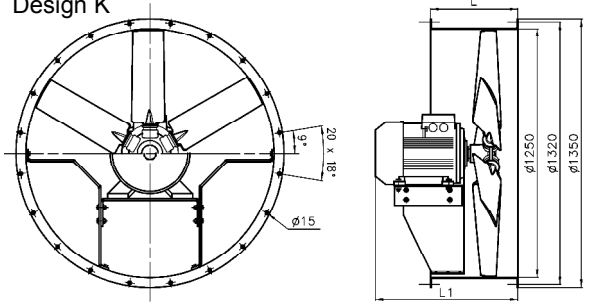

Design F

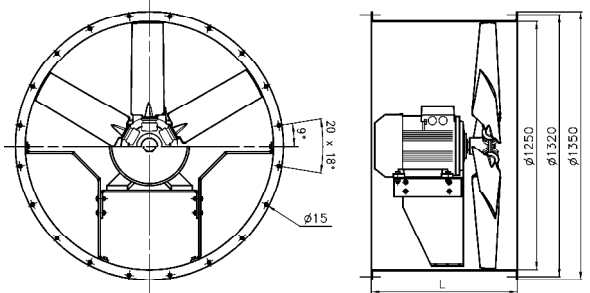

Pitch Angle	Relative spectrum							
	63	125	250	500	1000	2000	4000	8000
28°	-43	-34	-15	-7	-4	-6	-11	-21
31°	-42	-33	-15	-7	-4	-6	-10	-20
38°	-41	-32	-15	-8	-4	-6	-10	-19
43°	-41	-32	-16	-8	-4	-5	-9	-18
50°	-41	-31	-16	-8	-4	-5	-9	-17

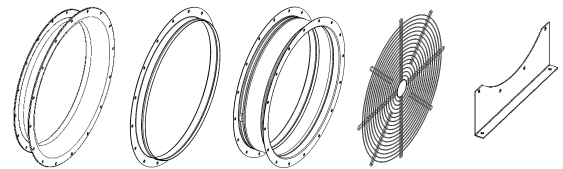

Accessories : see pages 100-102

Design	Pitch Angle	Type (G finish)	Part N°	Type (H finish)	Part N°	L1(mm)	L(mm)	Weight (kg)
K	28°	FV12V-8DK.H7.28.G	150825	FV12V-8DK.H7.28.H	150826	623	500	144
	31°	FV12V-8DK.I7.31.G	150829	FV12V-8DK.I7.31.H	150830	756	500	160
	38°	FV12V-8DK.I7.38.G	150833	FV12V-8DK.I7.38.H	150834	756	500	172
	43°	FV12V-8DK.K7.43.G	150837	FV12V-8DK.K7.43.H	150838	756	500	191
	50°	FV12V-8DK.M7.50.G	150841	FV12V-8DK.M7.50.H	150842	798	500	276
F	28°	FV12V-8DF.H7.28.G	150827	FV12V-8DF.H7.28.H	150828	---	760	167
	31°	FV12V-8DF.I7.31.G	150831	FV12V-8DF.I7.31.H	150832	---	760	183
	38°	FV12V-8DF.I7.38.G	150835	FV12V-8DF.I7.38.H	150836	---	760	195
	43°	FV12V-8DF.K7.43.G	150839	FV12V-8DF.K7.43.H	150840	---	760	214
	50°	FV12V-8DF.M7.50.G	150843	FV12V-8DF.M7.50.H	150844	---	930	316

FV14V-6D

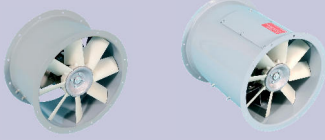

50Hz Motor	U	I	P ₂	n	
	V	A	kW	min ⁻¹	
22°	160 L	400	23,5	11	965
27°	180 L	400	29,5	15	965
29°	200 L	400	36,5	18,5	975
32°	200 L	400	43,5	22	975
38°	225 M	400	57	30	978

Standard Temperature Range : -30°C / +50°C

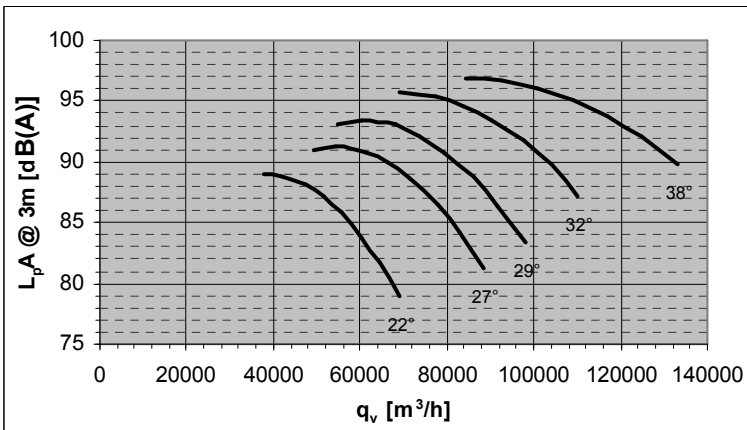
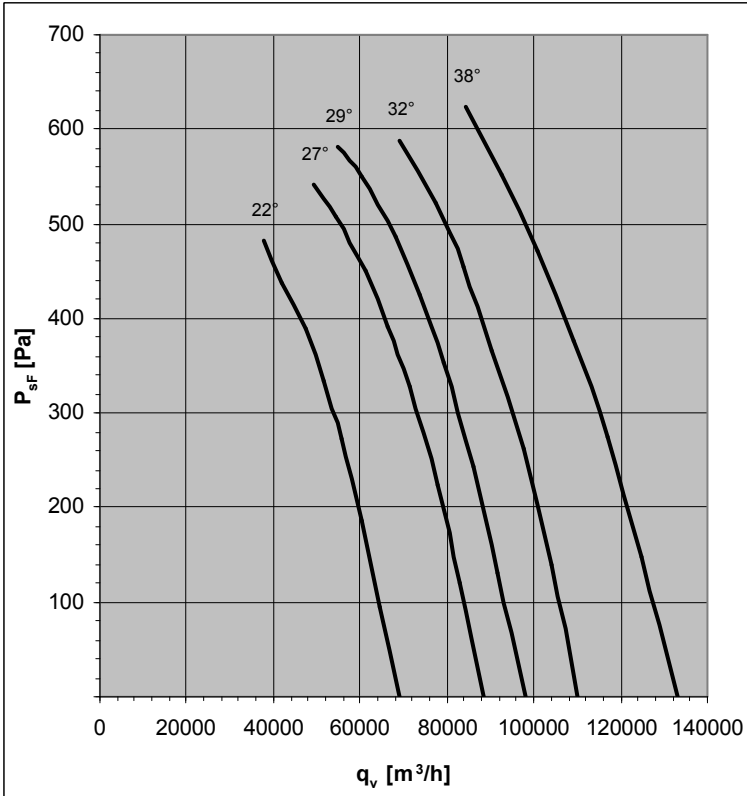

Design K

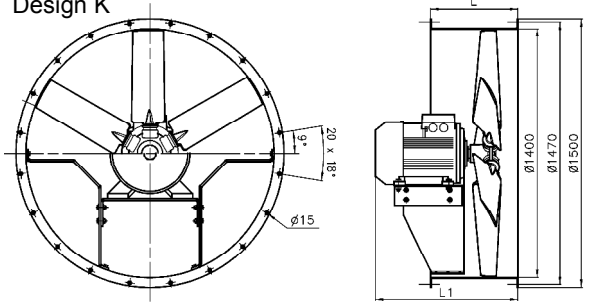

Design F

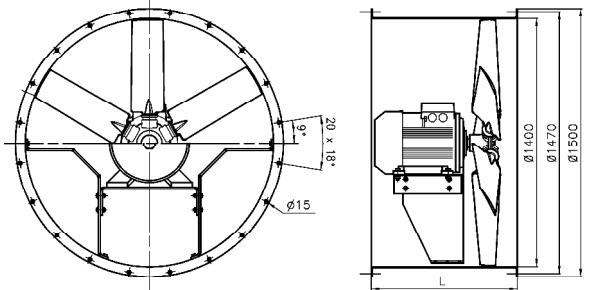

Pitch Angle	Relative spectrum							
	63	125	250	500	1000	2000	4000	8000
22°	-48	-38	-17	-8	-5	-7	-12	-23
27°	-48	-38	-17	-8	-5	-7	-12	-23
29°	-48	-37	-18	-9	-5	-6	-11	-22
32°	-48	-38	-19	-9	-5	-6	-11	-21
38°	-48	-37	-19	-9	-5	-6	-10	-21

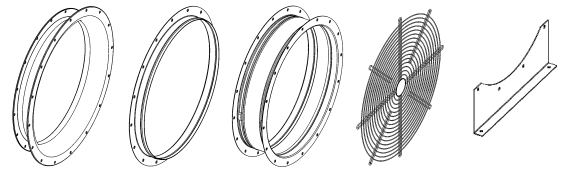

Accessories : see pages 100-102

Design	Pitch Angle	Type (G finish)	Part N°	Type (H finish)	Part N°	L1(mm)	L(mm)	Weight (kg)
K	22°	FV14V-6DK.K7.22.G	150901	FV14V-6DK.K7.22.H	150902	756	500	226
	27°	FV14V-6DK.M7.27.G	150905	FV14V-6DK.M7.27.H	150906	798	500	313
	29°	FV14V-6DK.N7.29.G	150909	FV14V-6DK.N7.29.H	150910	850	500	358
	32°	FV14V-6DK.N7.32.G	150913	FV14V-6DK.N7.32.H	150914	850	500	368
	38°	FV14V-6DK.R7.38.G	150917	FV14V-6DK.R7.38.H	150918	920	500	443
F	22°	FV14V-6DF.K7.22.G	150903	FV14V-6DF.K7.22.H	150904	---	760	261
	27°	FV14V-6DF.M7.27.G	150907	FV14V-6DF.M7.27.H	150908	---	930	372
	29°	FV14V-6DF.N7.29.G	150911	FV14V-6DF.N7.29.H	150912	---	930	417
	32°	FV14V-6DF.N7.32.G	150915	FV14V-6DF.N7.32.H	150916	---	930	427
	38°	FV14V-6DF.R7.38.G	150919	FV14V-6DF.R7.38.H	150920	---	930	502

FV14V-8D

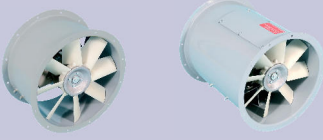

50Hz Motor	U	I	P ₂	n	
	V	A	kW	min ⁻¹	
25°	160 M	400	13,6	5,5	720
30°	160 L	400	18,6	7,5	715
36°	180 L	400	25	11	725
42°	200 L	400	32,5	15	725
47°	225 S	400	38,5	18,5	730

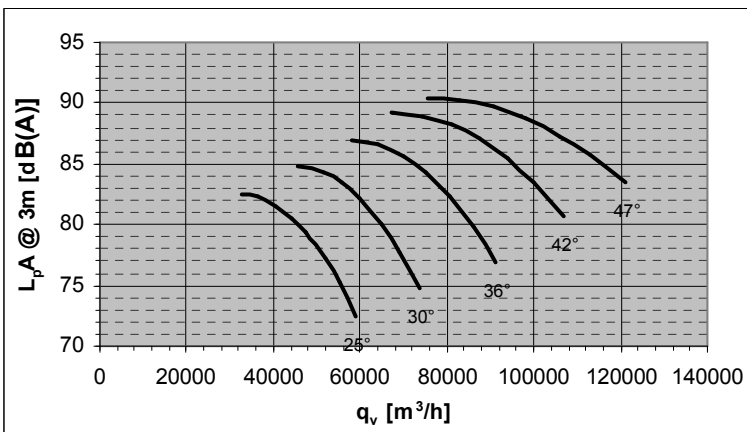
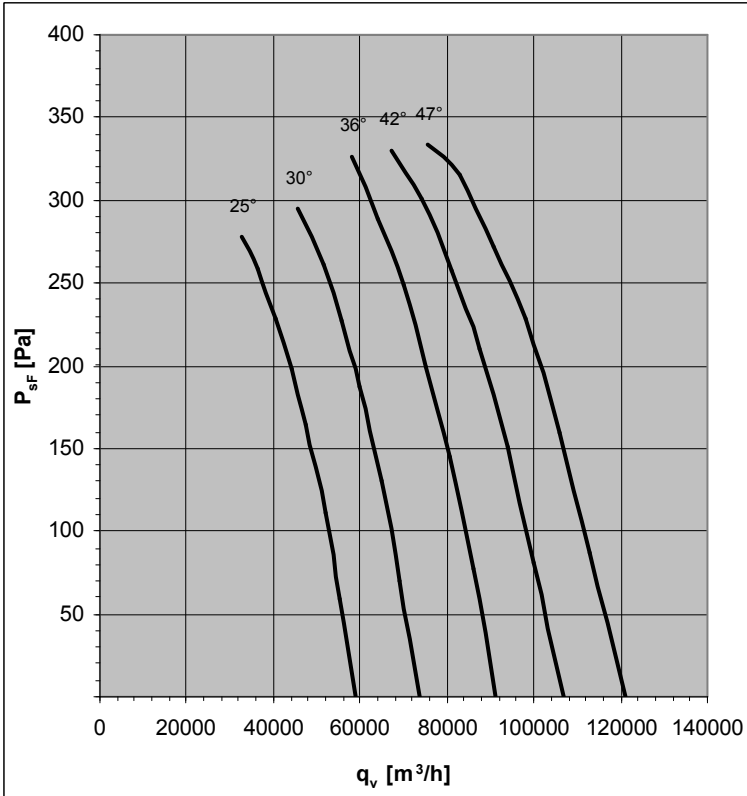

Design K

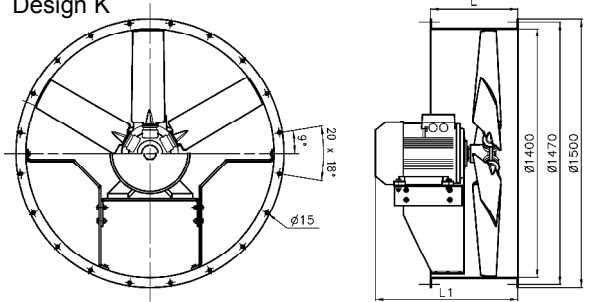

Design F

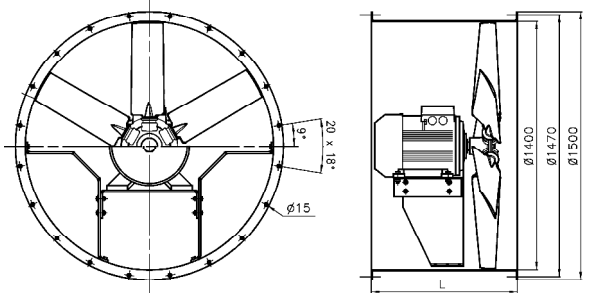

Pitch Angle	Relative spectrum							
	63	125	250	500	1000	2000	4000	8000
25°	-45	-36	-16	-8	-4	-6	-12	-22
30°	-45	-35	-16	-8	-4	-6	-11	-21
36°	-45	-35	-17	-8	-4	-6	-11	-20
42°	-45	-35	-18	-9	-5	-6	-10	-20
47°	-45	-35	-18	-9	-5	-6	-10	-19

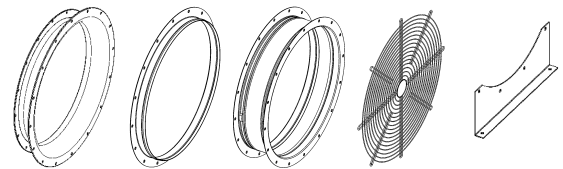

Accessories : see pages 100-102

Design	Pitch Angle	Type (G finish)	Part N°	Type (H finish)	Part N°	L1(mm)	L(mm)	Weight (kg)
K	25°	FV14V-8DK.I7.25.G	150921	FV14V-8DK.I7.25.H	150922	756	500	206
	30°	FV14V-8DK.K7.30.G	150925	FV14V-8DK.K7.30.H	150926	756	500	225
	36°	FV14V-8DK.M7.36.G	150929	FV14V-8DK.M7.36.H	150930	798	500	313
	42°	FV14V-8DK.N7.42.G	150933	FV14V-8DK.N7.42.H	150934	850	500	368
	47°	FV14V-8DK.P7.47.G	150937	FV14V-8DK.P7.47.H	150938	920	500	433
F	25°	FV14V-8DF.I7.25.G	150923	FV14V-8DF.I7.25.H	150924	---	760	241
	30°	FV14V-8DF.K7.30.G	150927	FV14V-8DF.K7.30.H	150928	---	760	260
	36°	FV14V-8DF.M7.36.G	150931	FV14V-8DF.M7.36.H	150932	---	930	372
	42°	FV14V-8DF.N7.42.G	150935	FV14V-8DF.N7.42.H	150936	---	930	427
	47°	FV14V-8DF.P7.47.G	150939	FV14V-8DF.P7.47.H	150940	---	930	492

Increased Temperature Range

Working Temperature : - 30°C / + 60°C

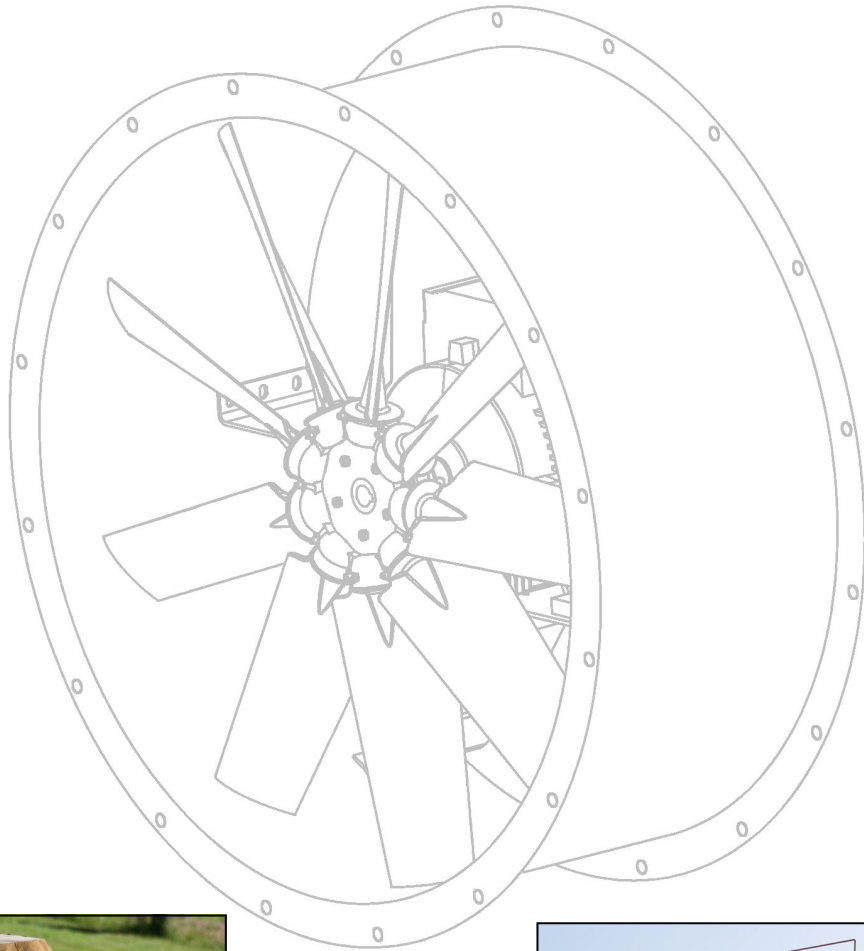

Increased Temperature Range : -30°C / +60°C

FV31V-2D

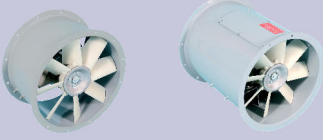

50Hz Motor	U	I	P ₂	n	
	V	A	kW	min ⁻¹	
25°	71 M	400	1	0,37	2740
30°	71 M	400	1	0,37	2740
35°	71 M	400	1,36	0,55	2800
40°	80 M	400	1,73	0,75	2855
45°	80 M	400	2,4	1,1	2845

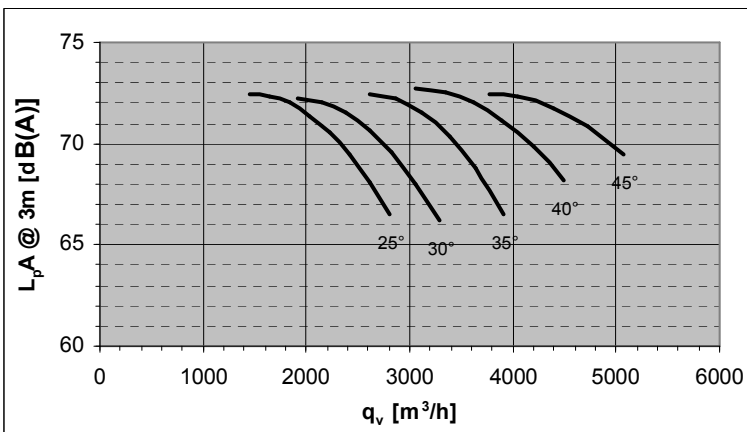
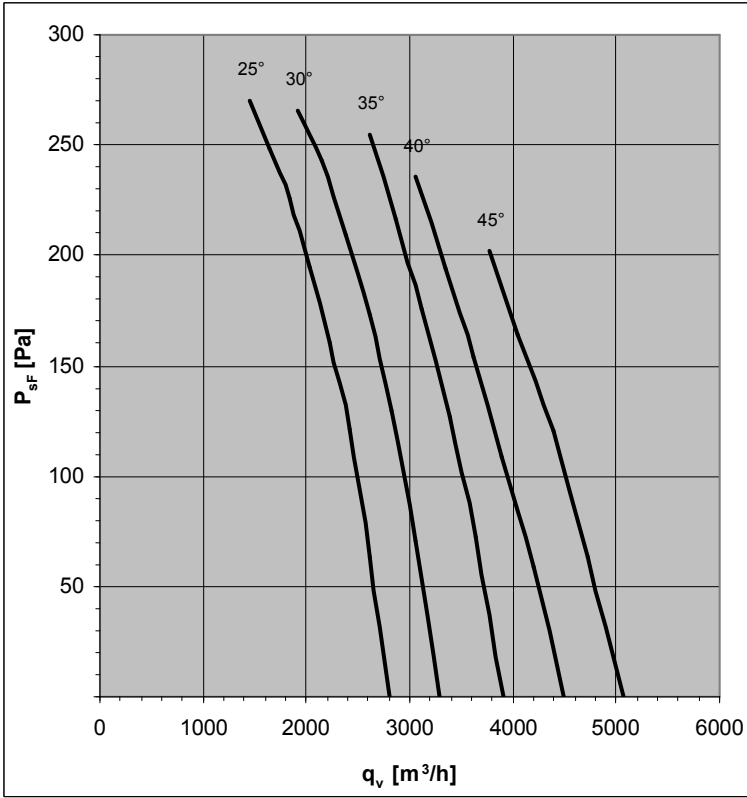

Design K

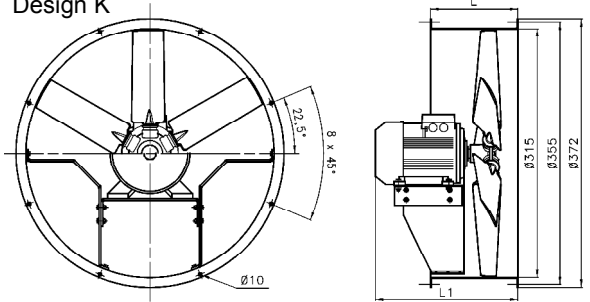

Design F

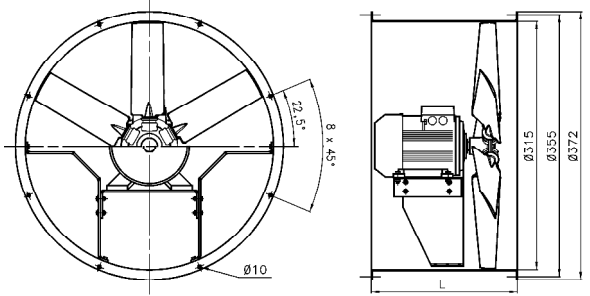

Pitch Angle	Relative spectrum							
	63	125	250	500	1000	2000	4000	8000
25°	-42	-33	-15	-7	-4	-6	-11	-20
30°	-41	-32	-15	-7	-4	-6	-10	-19
35°	-40	-31	-15	-7	-4	-5	-9	-18
40°	-40	-31	-15	-7	-4	-5	-9	-17
45°	-39	-30	-16	-8	-4	-5	-8	-17

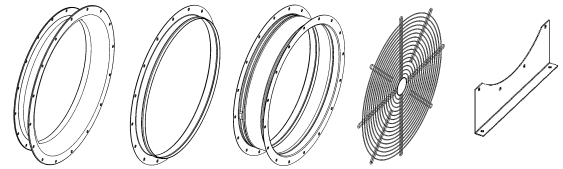

Accessories : see pages 100-102

Design	Pitch Angle	Type (G finish)	Part N°	Type (H finish)	Part N°	L1(mm)	L(mm)	Weight (kg)
K	25°	FV31V-2DK.A7.25.G	150000	FV31V-2DK.A7.25.H	150001	338	260	15
	30°	FV31V-2DK.A7.30.G	150004	FV31V-2DK.A7.30.H	150005	338	260	15
	35°	FV31V-2DK.A7.35.G	150008	FV31V-2DK.A7.35.H	150009	338	260	16
	40°	FV31V-2DK.B7.40.G	150040	FV31V-2DK.B7.40.H	150041	339	260	19
	45°	FV31V-2DK.B7.45.G	150044	FV31V-2DK.B7.45.H	150045	339	260	21
F	25°	FV31V-2DF.A7.25.G	150002	FV31V-2DF.A7.25.H	150003	---	350	17
	30°	FV31V-2DF.A7.30.G	150006	FV31V-2DF.A7.30.H	150007	---	350	17
	35°	FV31V-2DF.A7.35.G	150010	FV31V-2DF.A7.35.H	150011	---	350	18
	40°	FV31V-2DF.B7.40.G	150042	FV31V-2DF.B7.40.H	150043	---	350	21
	45°	FV31V-2DF.B7.45.G	150046	FV31V-2DF.B7.45.H	150047	---	350	23

FV31V-4D

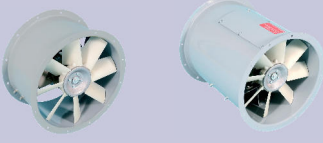

50Hz Motor	U	I	P ₂	n	
	V	A	kW	min ⁻¹	
25°	56 M	400	0,2	0,06	1350
30°	56 M	400	0,2	0,06	1350
35°	56 M	400	0,2	0,06	1350
40°	56 M	400	0,29	0,09	1350
45°	56 M	400	0,29	0,09	1350

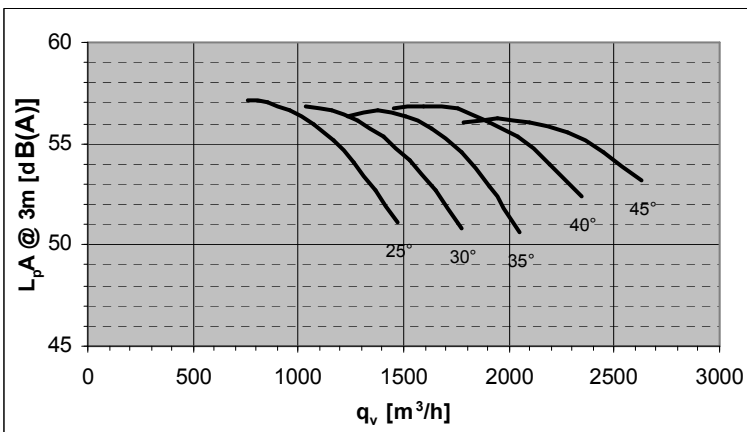
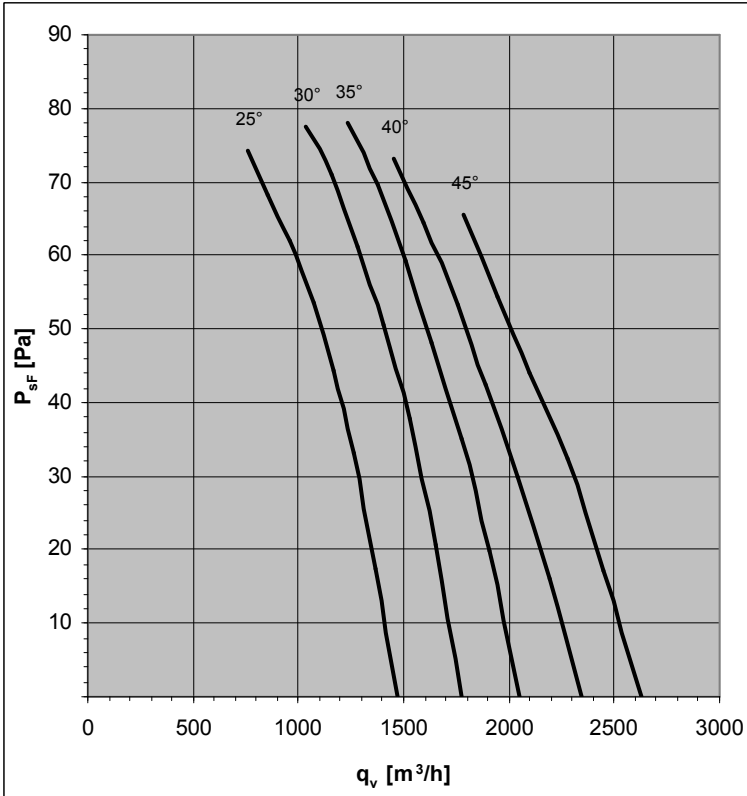

Design K

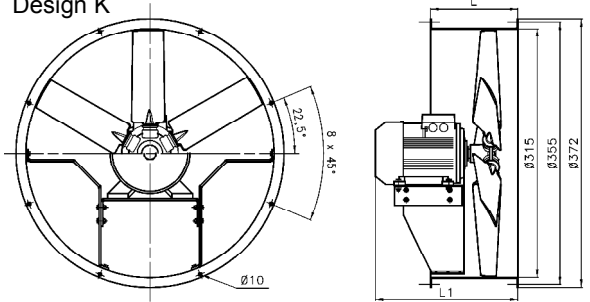

Design F

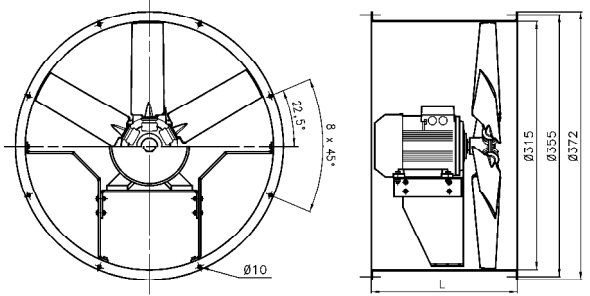

Pitch Angle	Relative spectrum							
	63	125	250	500	1000	2000	4000	8000
25°	-34	-27	-12	-6	-3	-5	-9	-17
30°	-33	-26	-12	-6	-3	-5	-8	-16
35°	-32	-25	-12	-6	-3	-4	-8	-15
40°	-32	-25	-12	-6	-3	-4	-7	-14
45°	-32	-25	-13	-6	-3	-4	-7	-14

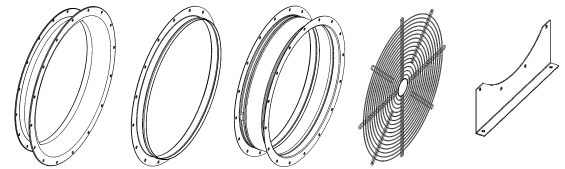

Accessories : see pages 100-102

Design	Pitch Angle	Type (G finish)	Part N°	Type (H finish)	Part N°	L1(mm)	L(mm)	Weight (kg)
K	25°	FV31V-4DK.87.25.G	150020	FV31V-4DK.87.25.H	150021	270	260	12
	30°	FV31V-4DK.87.30.G	150024	FV31V-4DK.87.30.H	150025	270	260	12
	35°	FV31V-4DK.87.35.G	150028	FV31V-4DK.87.35.H	150029	270	260	12
	40°	FV31V-4DK.87.40.G	150048	FV31V-4DK.87.40.H	150049	270	260	12
	45°	FV31V-4DK.87.45.G	150036	FV31V-4DK.87.45.H	150037	270	260	12
F	25°	FV31V-4DF.87.25.G	150022	FV31V-4DF.87.25.H	150023	---	350	14
	30°	FV31V-4DF.87.30.G	150026	FV31V-4DF.87.30.H	150027	---	350	14
	35°	FV31V-4DF.87.35.G	150030	FV31V-4DF.87.35.H	150031	---	350	14
	40°	FV31V-4DF.87.40.G	150050	FV31V-4DF.87.40.H	150051	---	350	14
	45°	FV31V-4DF.87.45.G	150038	FV31V-4DF.87.45.H	150039	---	350	14

FV35V-2D

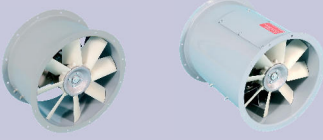

50Hz Motor	U	I	P ₂	n	
	V	A	kW	min ⁻¹	
25°	80 M	400	1,73	0,75	2855
30°	80 M	400	2,4	1,1	2845
35°	80 M	400	2,4	1,1	2845
40°	90 S	400	3,25	1,5	2860
45°	90 S	400	3,25	1,5	2860

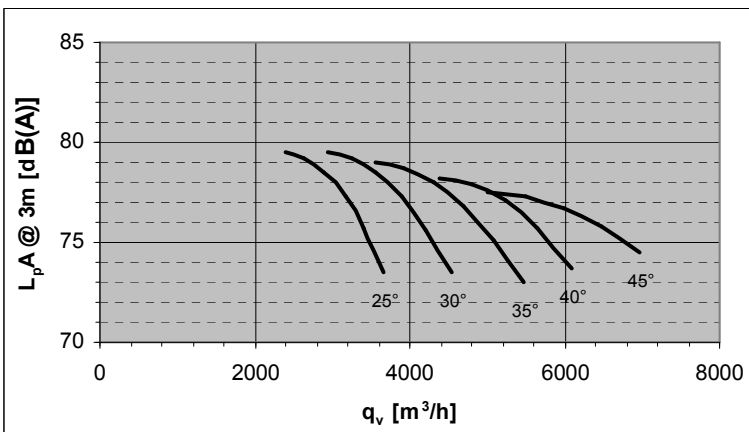
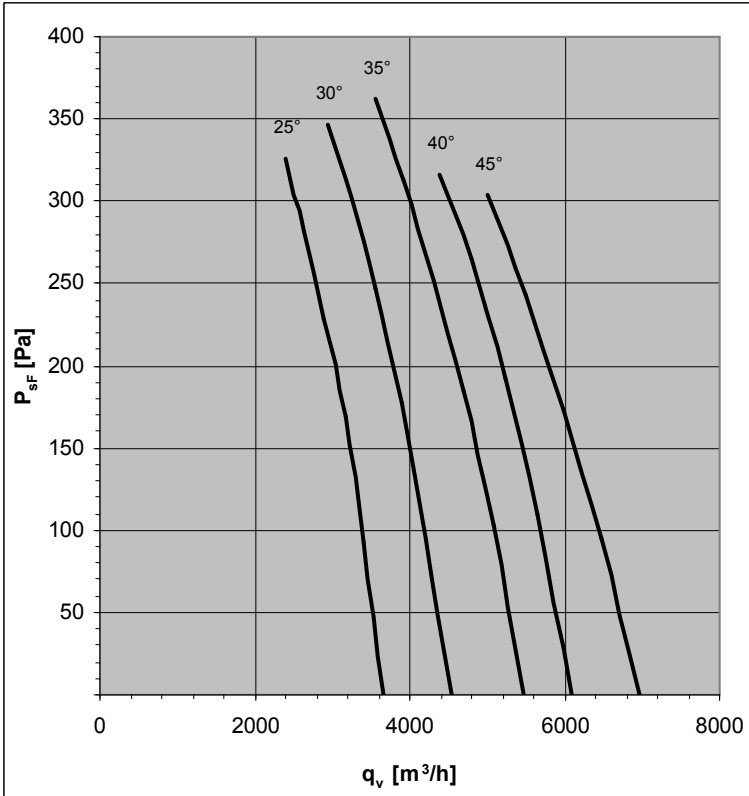

Design K

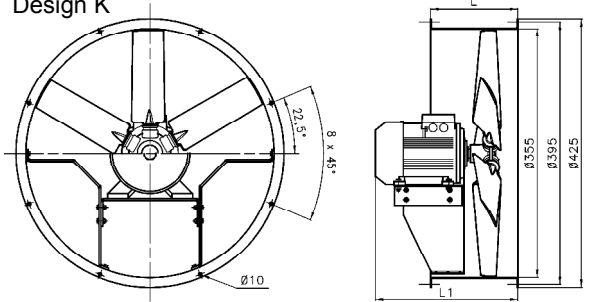

Design F

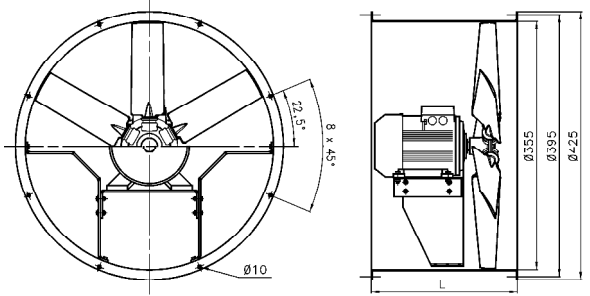

Pitch Angle	Relative spectrum							
	63	125	250	500	1000	2000	4000	8000
25°	-46	-36	-16	-8	-4	-6	-12	-22
30°	-44	-35	-16	-8	-4	-6	-11	-21
35°	-43	-34	-16	-8	-4	-6	-10	-20
40°	-42	-33	-16	-8	-4	-6	-10	-19
45°	-41	-32	-17	-8	-4	-5	-9	-18

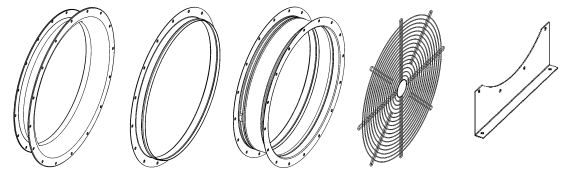

Accessories : see pages 100-102

Design	Pitch Angle	Type (G finish)	Part N°	Type (H finish)	Part N°	L1(mm)	L(mm)	Weight (kg)
K	25°	FV35V-2DK.B7.25.G	150092	FV35V-2DK.B7.25.H	150093	339	260	21
	30°	FV35V-2DK.B7.30.G	150096	FV35V-2DK.B7.30.H	150097	339	260	23
	35°	FV35V-2DK.B7.35.G	150060	FV35V-2DK.B7.35.H	150061	339	260	23
	40°	FV35V-2DK.C7.40.G	150100	FV35V-2DK.C7.40.H	150101	392	260	25
	45°	FV35V-2DK.C7.45.G	150068	FV35V-2DK.C7.45.H	150069	392	260	25
F	25°	FV35V-2DF.B7.25.G	150094	FV35V-2DF.B7.25.H	150095	---	400	24
	30°	FV35V-2DF.B7.30.G	150098	FV35V-2DF.B7.30.H	150099	---	400	26
	35°	FV35V-2DF.B7.35.G	150062	FV35V-2DF.B7.35.H	150063	---	400	26
	40°	FV35V-2DF.C7.40.G	150102	FV35V-2DF.C7.40.H	150103	---	400	28
	45°	FV35V-2DF.C7.45.G	150070	FV35V-2DF.C7.45.H	150071	---	400	28

FV35V-4D

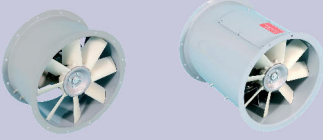

50Hz Motor	U	I	P ₂	n	
	V	A	kW	min ⁻¹	
25°	56 M	400	0,29	0,09	1350
30°	56 M	400	0,29	0,09	1350
35°	63 M	400	0,42	0,12	1350
40°	63 M	400	0,58	0,18	1350
45°	63 M	400	0,58	0,18	1350

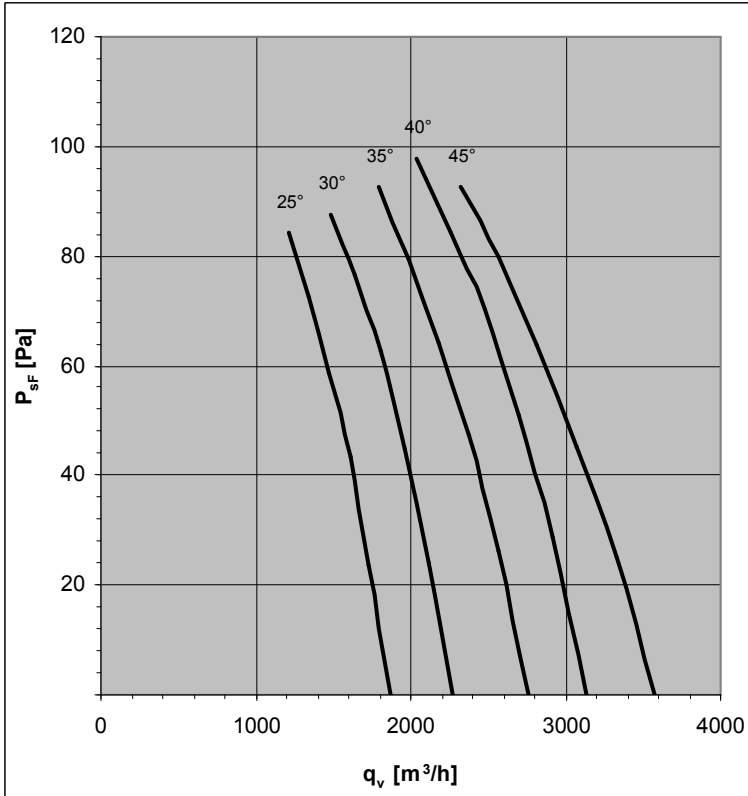

Design K

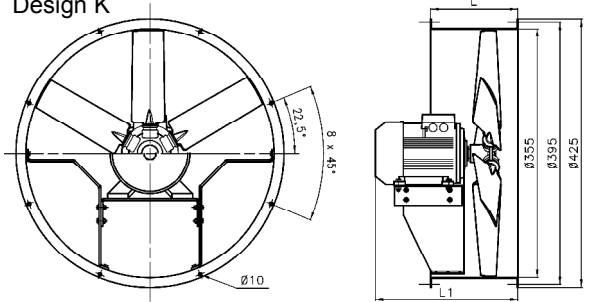

Design F

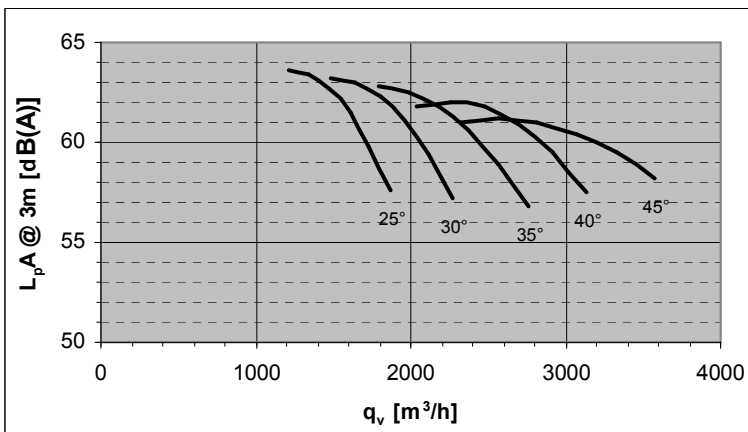
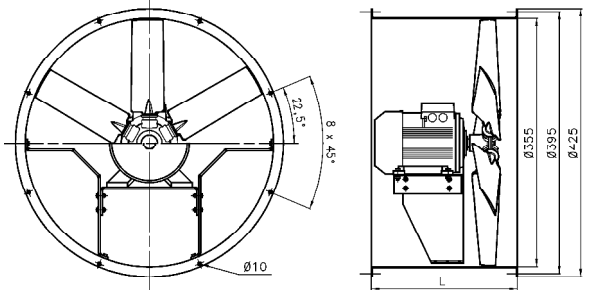

Pitch Angle	Relative spectrum							
	63	125	250	500	1000	2000	4000	8000
25°	-38	-30	-13	-6	-4	-5	-10	-18
30°	-36	-29	-13	-6	-3	-5	-9	-17
35°	-35	-28	-13	-6	-3	-5	-8	-16
40°	-35	-27	-13	-7	-3	-5	-8	-15
45°	-34	-26	-14	-7	-3	-4	-7	-14

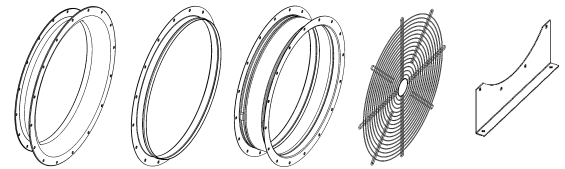

Accessories : see pages 100-102

Design	Pitch Angle	Type (G finish)	Part N°	Type (H finish)	Part N°	L1(mm)	L(mm)	Weight (kg)
K	25°	FV35V-4DK.87.25.G	150104	FV35V-4DK.87.25.H	150105	270	260	14
	30°	FV35V-4DK.87.30.G	150076	FV35V-4DK.87.30.H	150077	270	260	14
	35°	FV35V-4DK.97.35.G	150080	FV35V-4DK.97.35.H	150081	295	260	14
	40°	FV35V-4DK.97.40.G	150108	FV35V-4DK.97.40.H	150109	295	260	15
	45°	FV35V-4DK.97.45.G	150088	FV35V-4DK.97.45.H	150089	295	260	15
F	25°	FV35V-4DF.87.25.G	150106	FV35V-4DF.87.25.H	150107	---	400	17
	30°	FV35V-4DF.87.30.G	150078	FV35V-4DF.87.30.H	150079	---	400	17
	35°	FV35V-4DF.97.35.G	150082	FV35V-4DF.97.35.H	150083	---	400	17
	40°	FV35V-4DF.97.40.G	150110	FV35V-4DF.97.40.H	150111	---	400	18
	45°	FV35V-4DF.97.45.G	150090	FV35V-4DF.97.45.H	150091	---	400	18

FV40V-2D

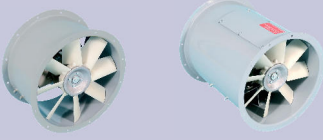

50Hz Motor	U	I	P ₂	n	
	V	A	kW	min ⁻¹	
25°	80 M	400	2,4	1,1	2845
30°	90 S	400	3,25	1,5	2860
35°	90 L	400	4,55	2,2	2880
40°	90 L	400	4,55	2,2	2880
45°	100 L	400	6	3	2835

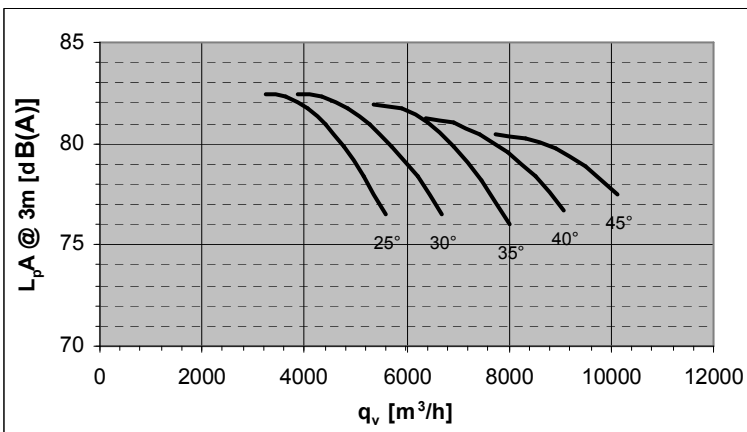
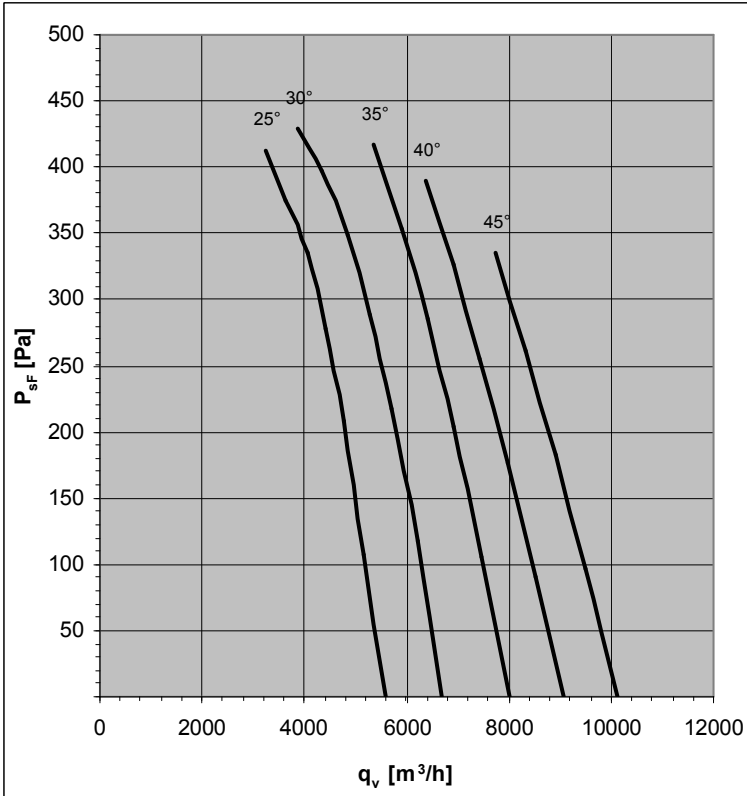

Design K

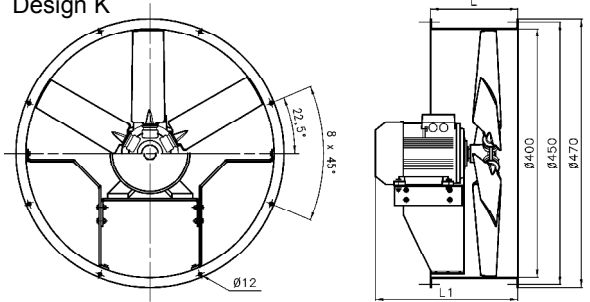

Design F

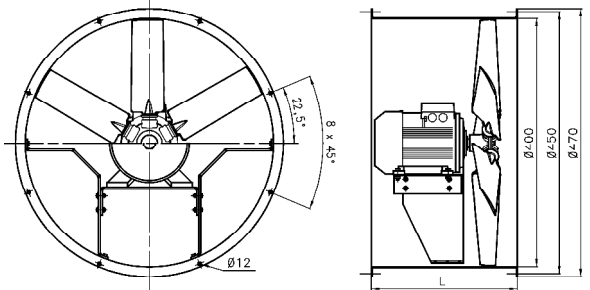

Pitch Angle	Relative spectrum							
	63	125	250	500	1000	2000	4000	8000
25°	-47	-37	-16	-8	-4	-6	-12	-23
30°	-46	-36	-16	-8	-4	-6	-11	-22
35°	-44	-35	-17	-8	-4	-6	-10	-20
40°	-44	-34	-17	-8	-4	-6	-10	-19
45°	-43	-33	-17	-8	-4	-6	-9	-18

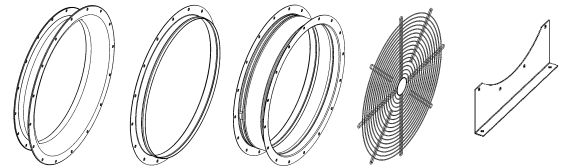

Accessories : see pages 100-102

Design	Pitch Angle	Type (G finish)	Part N°	Type (H finish)	Part N°	L1(mm)	L(mm)	Weight (kg)
K	25°	FV40V-2DK.B7.25.G	150112	FV40V-2DK.B7.25.H	150113	339	260	24
	30°	FV40V-2DK.C7.30.G	150172	FV40V-2DK.C7.30.H	150173	392	260	26
	35°	FV40V-2DK.D7.35.G	150176	FV40V-2DK.D7.35.H	150177	392	260	29
	40°	FV40V-2DK.D7.40.G	150124	FV40V-2DK.D7.40.H	150125	392	260	29
	45°	FV40V-2DK.E7.45.G	150128	FV40V-2DK.E7.45.H	150129	460	260	33
F	25°	FV40V-2DF.B7.25.G	150114	FV40V-2DF.B7.25.H	150115	---	470	29
	30°	FV40V-2DF.C7.30.G	150174	FV40V-2DF.C7.30.H	150175	---	470	31
	35°	FV40V-2DF.D7.35.G	150178	FV40V-2DF.D7.35.H	150179	---	470	33
	40°	FV40V-2DF.D7.40.G	150126	FV40V-2DF.D7.40.H	150127	---	470	33
	45°	FV40V-2DF.E7.45.G	150130	FV40V-2DF.E7.45.H	150131	---	470	38

FV40V-4D



50Hz Motor	U	I	P ₂	n	
	V	A	kW	min ⁻¹	
25°	63 M	400	0,42	0,12	1350
30°	63 M	400	0,58	0,18	1350
35°	63 M	400	0,58	0,18	1350
40°	71 M	400	0,77	0,25	1350
45°	71 M	400	1,06	0,37	1370

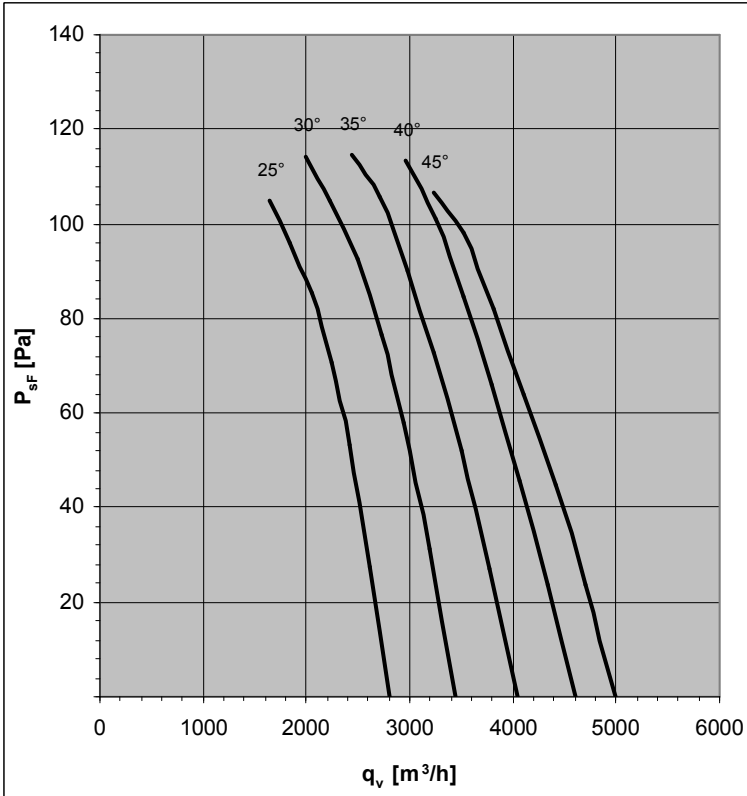

Design K

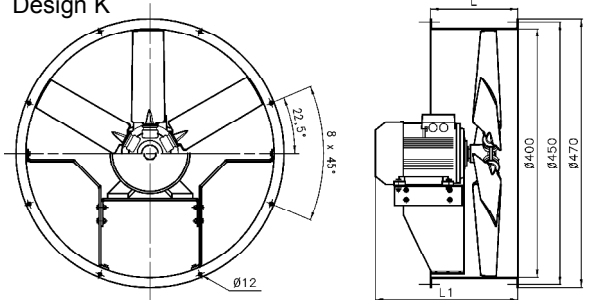

Design F

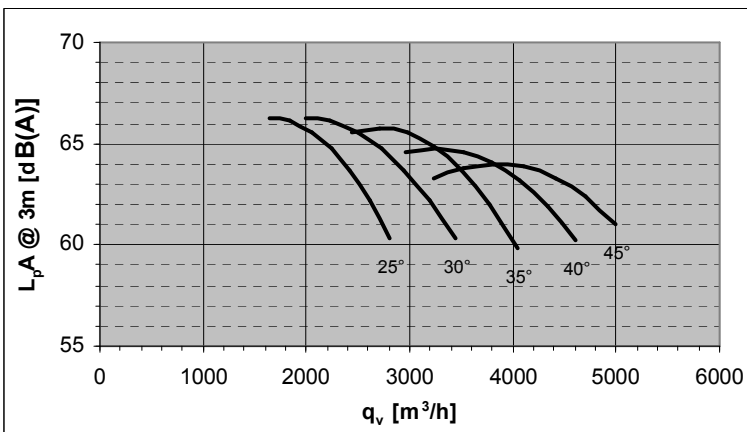
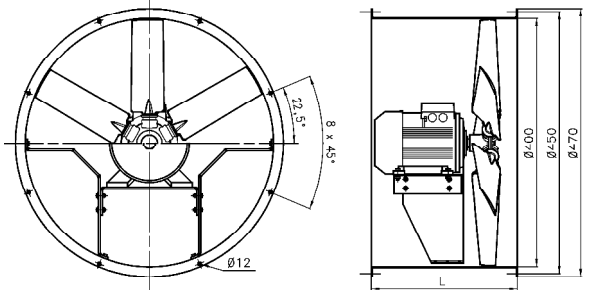

Pitch Angle	Relative spectrum							
	63	125	250	500	1000	2000	4000	8000
25°	-39	-31	-13	-7	-4	-5	-10	-19
30°	-38	-30	-14	-7	-4	-5	-9	-18
35°	-37	-29	-14	-7	-4	-5	-9	-17
40°	-36	-28	-14	-7	-4	-5	-8	-16
45°	-35	-27	-14	-7	-4	-5	-8	-15

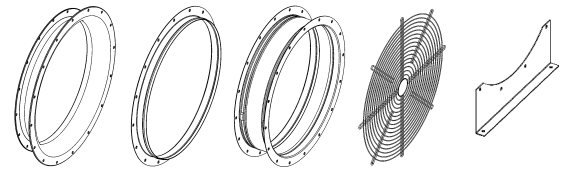

Accessories : see pages 100-102

Design	Pitch Angle	Type (G finish)	Part N°	Type (H finish)	Part N°	L1(mm)	L(mm)	Weight (kg)
K	25°	FV40V-4DK.97.25.G	150180	FV40V-4DK.97.25.H	150181	295	260	16
	30°	FV40V-4DK.97.30.G	150184	FV40V-4DK.97.30.H	150185	295	260	16
	35°	FV40V-4DK.97.35.G	150140	FV40V-4DK.97.35.H	150141	295	260	16
	40°	FV40V-4DK.A7.40.G	150144	FV40V-4DK.A7.40.H	150145	338	260	18
	45°	FV40V-4DK.A7.45.G	150188	FV40V-4DK.A7.45.H	150189	338	260	19
F	25°	FV40V-4DF.97.25.G	150182	FV40V-4DF.97.25.H	150183	---	470	20
	30°	FV40V-4DF.97.30.G	150186	FV40V-4DF.97.30.H	150187	---	470	21
	35°	FV40V-4DF.97.35.G	150142	FV40V-4DF.97.35.H	150143	---	470	21
	40°	FV40V-4DF.A7.40.G	150146	FV40V-4DF.A7.40.H	150147	---	470	22
	45°	FV40V-4DF.A7.45.G	150190	FV40V-4DF.A7.45.H	150191	---	470	24

FV40V-6D

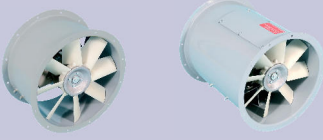

50Hz Motor	U	I	P ₂	n	
	V	A	kW	min ⁻¹	
25°	63 M	400	0,44	0,09	850
30°	63 M	400	0,44	0,09	850
35°	63 M	400	0,44	0,09	850
40°	63 M	400	0,44	0,09	850
45°	63 M	400	0,44	0,09	850

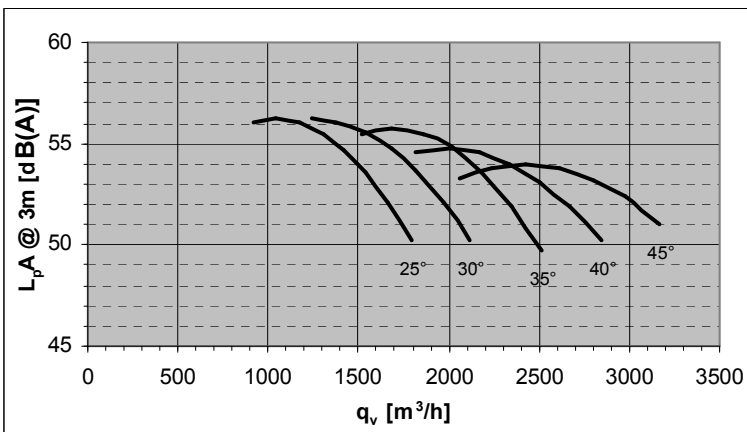
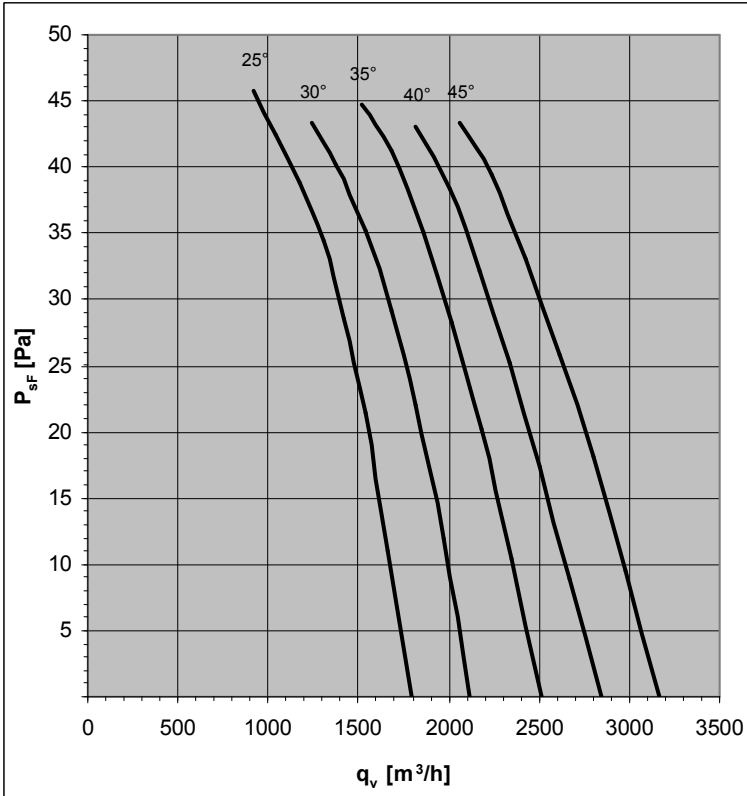

Design K

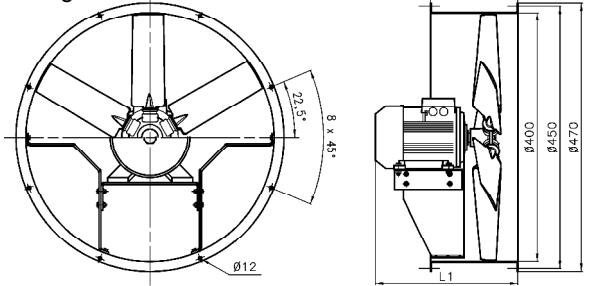

Design F

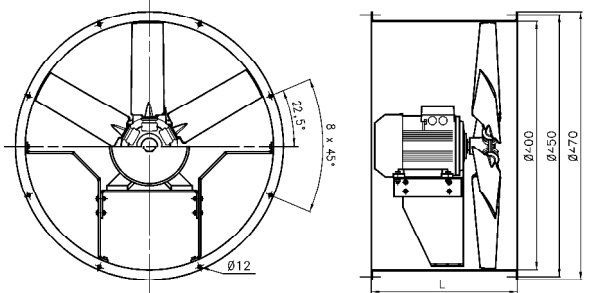

Pitch Angle	Relative spectrum							
	63	125	250	500	1000	2000	4000	8000
25°	-34	-27	-12	-6	-3	-5	-9	-16
30°	-33	-26	-12	-6	-3	-4	-8	-16
35°	-32	-25	-12	-6	-3	-4	-8	-15
40°	-31	-24	-12	-6	-3	-4	-7	-14
45°	-31	-24	-12	-6	-3	-4	-7	-13

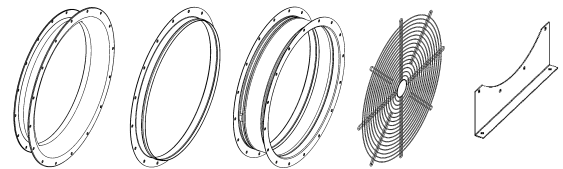

Accessories : see pages 100-102

Design	Pitch Angle	Type (G finish)	Part N°	Type (H finish)	Part N°	L1(mm)	L(mm)	Weight (kg)
K	25°	FV40V-6DK.97.25.G	150152	FV40V-6DK.97.25.H	150153	295	260	16
	30°	FV40V-6DK.97.30.G	150156	FV40V-6DK.97.30.H	150157	295	260	16
	35°	FV40V-6DK.97.35.G	150160	FV40V-6DK.97.35.H	150161	295	260	16
	40°	FV40V-6DK.97.40.G	150164	FV40V-6DK.97.40.H	150165	295	260	16
	45°	FV40V-6DK.97.45.G	150168	FV40V-6DK.97.45.H	150169	295	260	16
F	25°	FV40V-6DF.97.25.G	150154	FV40V-6DF.97.25.H	150155	---	470	21
	30°	FV40V-6DF.97.30.G	150158	FV40V-6DF.97.30.H	150159	---	470	21
	35°	FV40V-6DF.97.35.G	150162	FV40V-6DF.97.35.H	150163	---	470	21
	40°	FV40V-6DF.97.40.G	150166	FV40V-6DF.97.40.H	150167	---	470	21
	45°	FV40V-6DF.97.45.G	150170	FV40V-6DF.97.45.H	150171	---	470	21

FV45V-2D

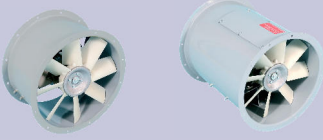

50Hz Motor	U	I	P ₂	n	
	V	A	kW	min ⁻¹	
25°	90 L	4,00	4,55	2,2	2880
30°	90 L	4,00	4,55	2,2	2880
35°	112 M	4,00	7,9	4	2930
40°	112 M	4,00	7,9	4	2930
45°	112 M	4,00	10,6	5,5	2905

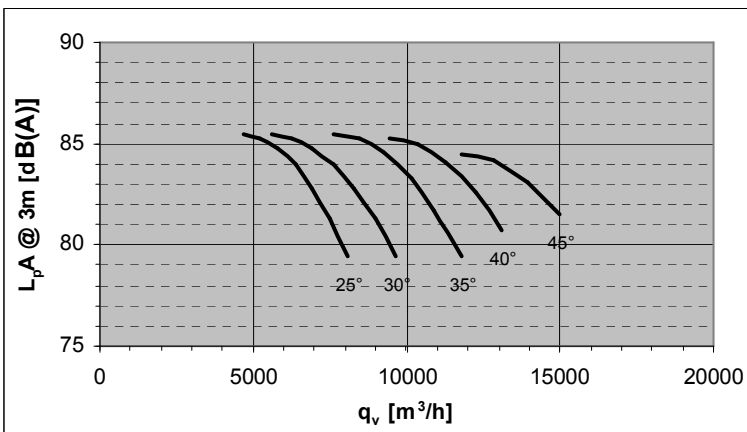
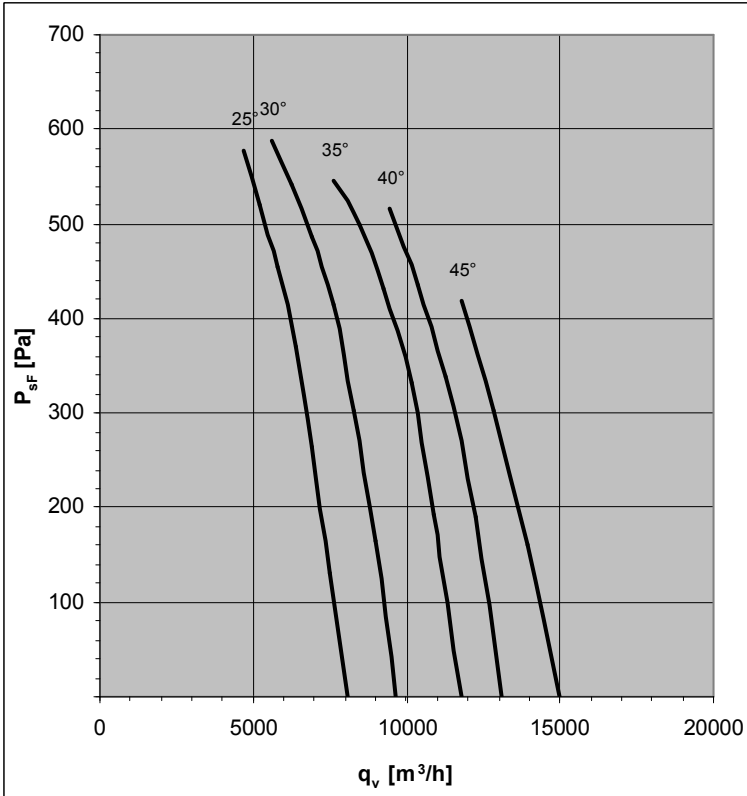

Design K

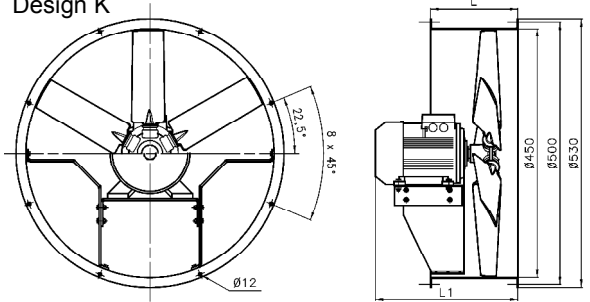

Design F

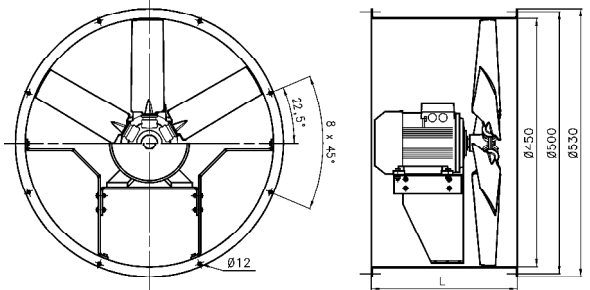

Pitch Angle	Relative spectrum							
	63	125	250	500	1000	2000	4000	8000
25°	-49	-38	-17	-8	-5	-7	-12	-23
30°	-47	-37	-17	-8	-5	-6	-12	-22
35°	-46	-36	-17	-8	-4	-6	-11	-21
40°	-45	-35	-18	-9	-5	-6	-10	-20
45°	-45	-34	-18	-9	-5	-6	-10	-19

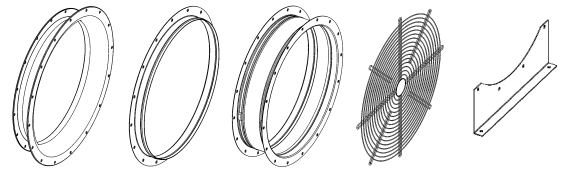

Accessories : see pages 100-102

Design	Pitch Angle	Type (G finish)	Part N°	Type (H finish)	Part N°	L1(mm)	L(mm)	Weight (kg)
K	25°	FV45V-2DK.D7.25.G	150192	FV45V-2DK.D7.25.H	150193	392	260	31
	30°	FV45V-2DK.D7.30.G	150196	FV45V-2DK.D7.30.H	150197	392	260	31
	35°	FV45V-2DK.F7.35.G	150252	FV45V-2DK.F7.35.H	150253	460	385	49
	40°	FV45V-2DK.F7.40.G	150204	FV45V-2DK.F7.40.H	150205	460	385	49
	45°	FV45V-2DK.F7.45.G	150208	FV45V-2DK.F7.45.H	150209	460	385	59
F	25°	FV45V-2DF.D7.25.G	150194	FV45V-2DF.D7.25.H	150195	---	470	36
	30°	FV45V-2DF.D7.30.G	150198	FV45V-2DF.D7.30.H	150199	---	470	36
	35°	FV45V-2DF.F7.35.G	150254	FV45V-2DF.F7.35.H	150255	---	530	53
	40°	FV45V-2DF.F7.40.G	150206	FV45V-2DF.F7.40.H	150207	---	530	53
	45°	FV45V-2DF.F7.45.G	150210	FV45V-2DF.F7.45.H	150211	---	530	63

FV45V-4D



50Hz Motor	U	I	P ₂	n
	V	A	kW	min ⁻¹
25°	63 M	400	0,58	1350
30°	71 M	400	0,77	1350
35°	71 M	400	1,06	1370
40°	80 M	400	1,93	1395
45°	80 M	400	1,93	1395

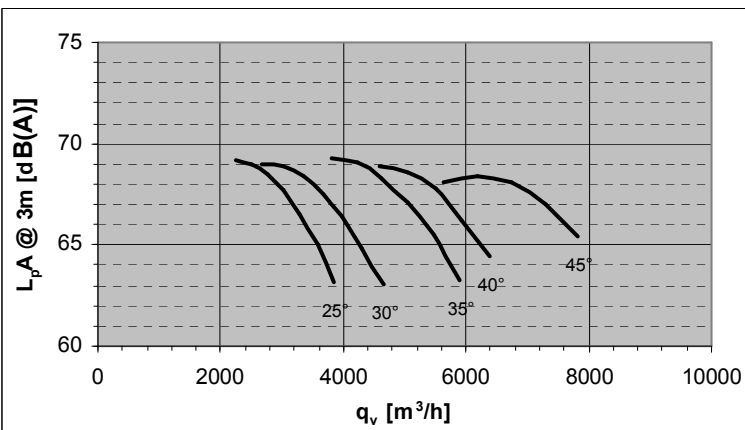
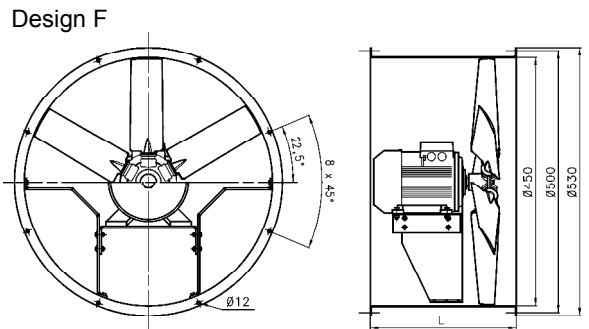
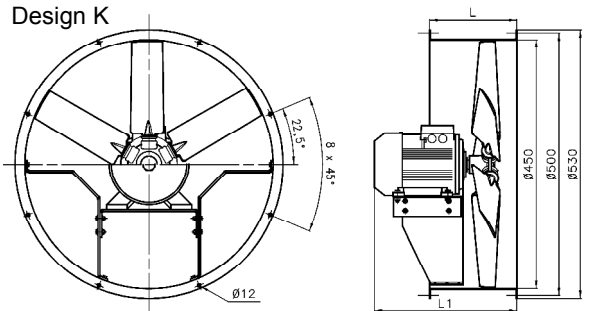
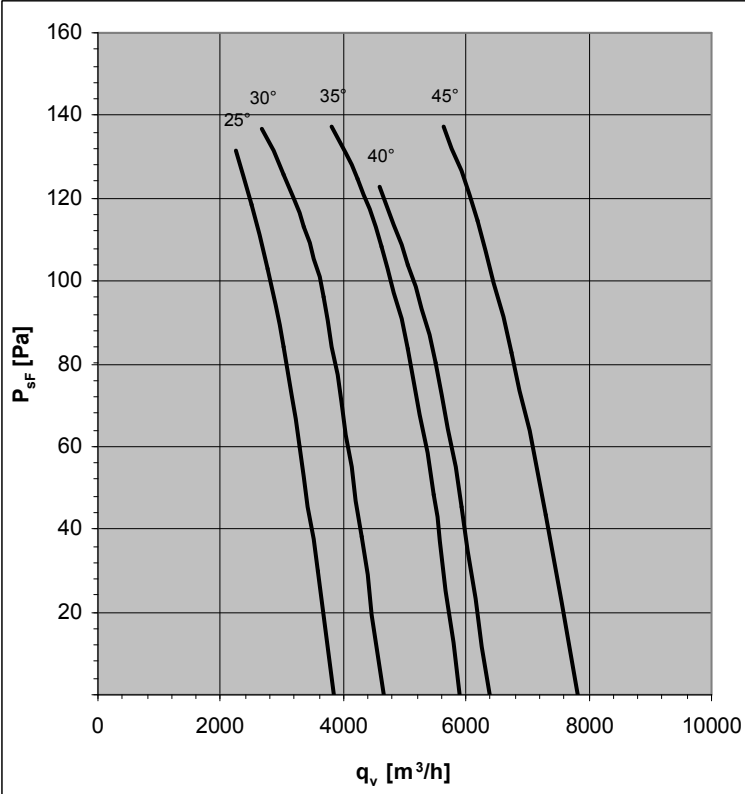

Pitch Angle	Relative spectrum							
	63	125	250	500	1000	2000	4000	8000
25°	-40	-32	-14	-7	-4	-6	-10	-20
30°	-39	-31	-14	-7	-4	-5	-10	-18
35°	-38	-30	-14	-7	-4	-5	-9	-17
40°	-38	-29	-15	-7	-4	-5	-9	-17
45°	-37	-29	-15	-7	-4	-5	-8	-16

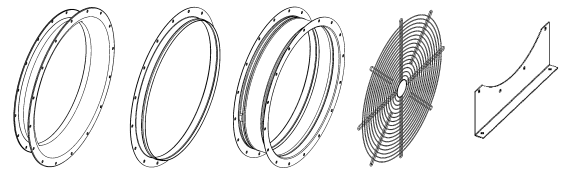

Accessories : see pages 100-102

Design	Pitch Angle	Type (G finish)	Part N°	Type (H finish)	Part N°	L1(mm)	L(mm)	Weight (kg)
K	25°	FV45V-4DK.97.25.G	150212	FV45V-4DK.97.25.H	150213	343	260	20
	30°	FV45V-4DK.A7.30.G	150216	FV45V-4DK.A7.30.H	150217	343	260	21
	35°	FV45V-4DK.A7.35.G	150220	FV45V-4DK.A7.35.H	150221	343	260	22
	40°	FV45V-4DK.B7.40.G	150256	FV45V-4DK.B7.40.H	150257	343	260	25
	45°	FV45V-4DK.B7.45.G	150228	FV45V-4DK.B7.45.H	150229	343	260	25
F	25°	FV45V-4DF.97.25.G	150214	FV45V-4DF.97.25.H	150215	---	470	25
	30°	FV45V-4DF.A7.30.G	150218	FV45V-4DF.A7.30.H	150219	---	470	26
	35°	FV45V-4DF.A7.35.G	150222	FV45V-4DF.A7.35.H	150223	---	470	27
	40°	FV45V-4DF.B7.40.G	150258	FV45V-4DF.B7.40.H	150259	---	470	30
	45°	FV45V-4DF.B7.45.G	150230	FV45V-4DF.B7.45.H	150231	---	470	30

FV45V-6D

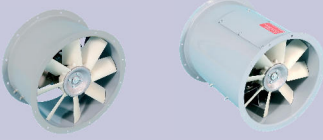

50Hz Motor	U	I	P ₂	n	
	V	A	kW	min ⁻¹	
25°	63 M	400	0,44	0,09	850
30°	63 M	400	0,44	0,09	850
35°	63 M	400	0,44	0,09	850
40°	71 M	400	0,72	0,18	850
45°	71 M	400	0,72	0,18	850

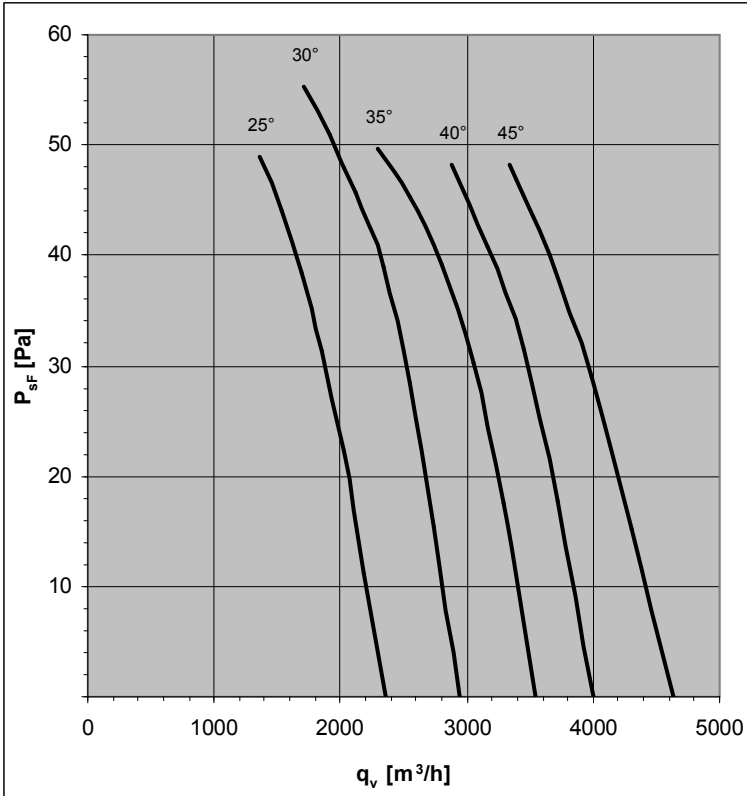

Design K

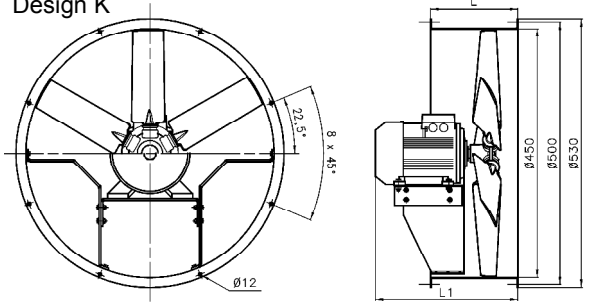

Design F

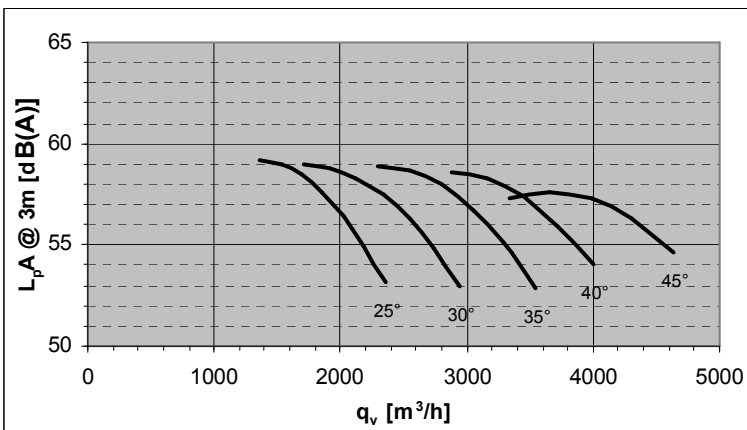
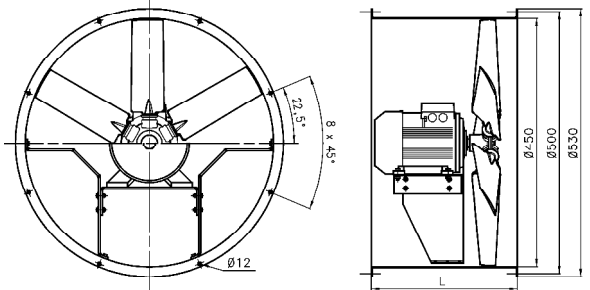

Pitch Angle	Relative spectrum							
	63	125	250	500	1000	2000	4000	8000
25°	-35	-28	-12	-6	-3	-5	-9	-17
30°	-34	-27	-12	-6	-3	-5	-8	-16
35°	-33	-26	-12	-6	-3	-4	-8	-15
40°	-33	-26	-13	-6	-3	-4	-7	-15
45°	-32	-25	-13	-6	-3	-4	-7	-14

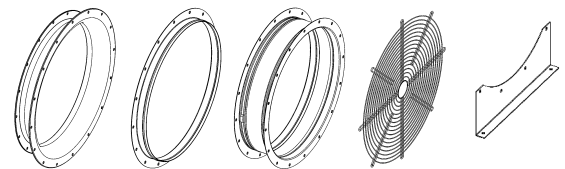

Accessories : see pages 100-102

Design	Pitch Angle	Type (G finish)	Part N°	Type (H finish)	Part N°	L1(mm)	L(mm)	Weight (kg)
K	25°	FV45V-6DK.97.25.G	150232	FV45V-6DK.97.25.H	150233	343	260	20
	30°	FV45V-6DK.97.30.G	150236	FV45V-6DK.97.30.H	150237	343	260	20
	35°	FV45V-6DK.97.35.G	150240	FV45V-6DK.97.35.H	150241	343	260	20
	40°	FV45V-6DK.A7.40.G	150260	FV45V-6DK.A7.40.H	150261	343	260	21
	45°	FV45V-6DK.A7.45.G	150248	FV45V-6DK.A7.45.H	150249	343	260	21
F	25°	FV45V-6DF.97.25.G	150234	FV45V-6DF.97.25.H	150235	---	470	25
	30°	FV45V-6DF.97.30.G	150238	FV45V-6DF.97.30.H	150239	---	470	25
	35°	FV45V-6DF.97.35.G	150242	FV45V-6DF.97.35.H	150243	---	470	25
	40°	FV45V-6DF.A7.40.G	150262	FV45V-6DF.A7.40.H	150263	---	470	26
	45°	FV45V-6DF.A7.45.G	150250	FV45V-6DF.A7.45.H	150251	---	470	26

FV50V-2D



50Hz Motor	U	I	P ₂	n	
	V	A	kW	min ⁻¹	
25°	100 L	400	6	3	2835
30°	112 M	400	7,9	4	2930
35°	132 S	400	10,4	5,5	2905
40°	132 S	400	14	7,5	2925
45°	132 S	400	14	7,5	2925

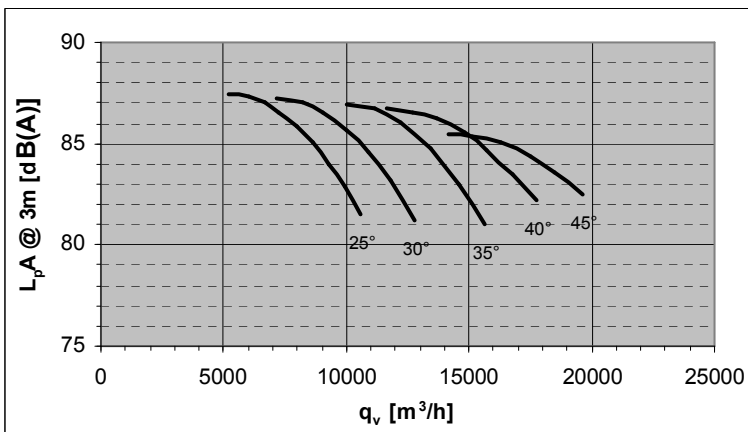
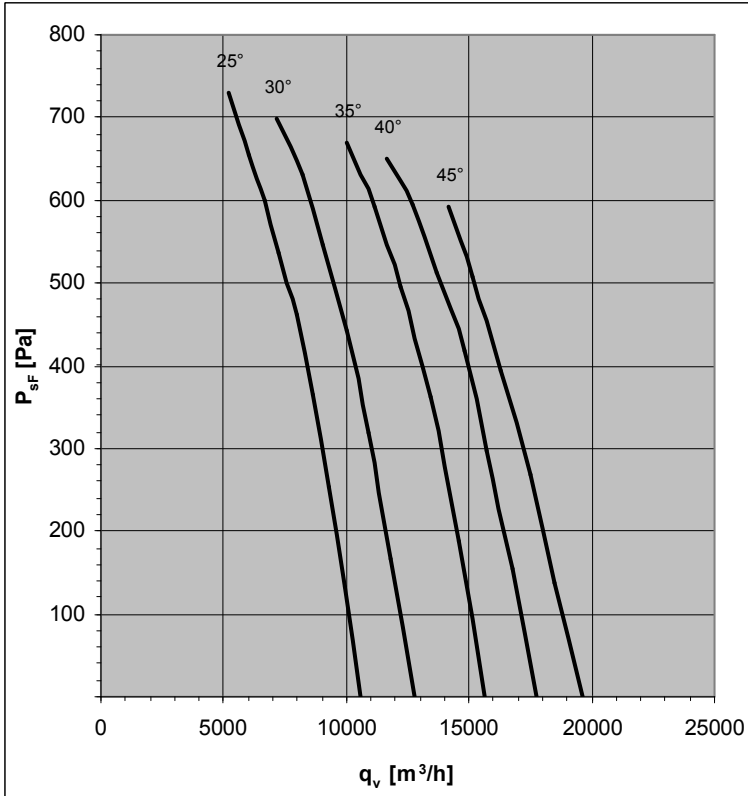

Design K

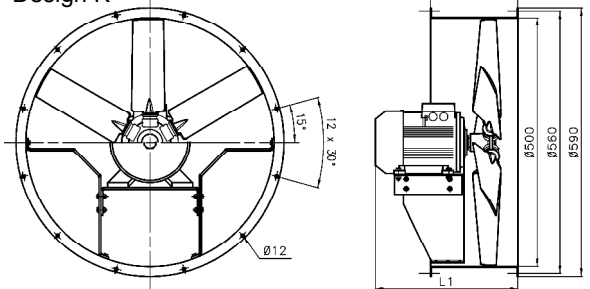

Design F

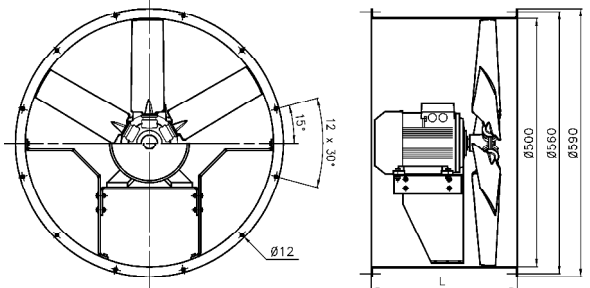

Pitch Angle	Relative spectrum							
	63	125	250	500	1000	2000	4000	8000
25°	-50	-39	-17	-8	-5	-7	-13	-24
30°	-48	-38	-17	-8	-5	-7	-12	-23
35°	-47	-37	-17	-9	-5	-6	-11	-21
40°	-46	-36	-18	-9	-5	-6	-10	-20
45°	-45	-35	-18	-9	-5	-6	-10	-19

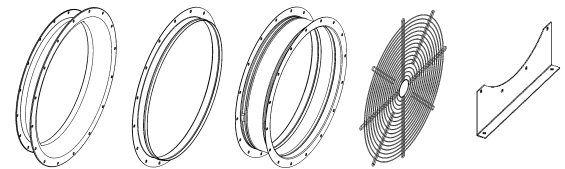

Accessories : see pages 100-102

Design	Pitch Angle	Type (G finish)	Part N°	Type (H finish)	Part N°	L1(mm)	L(mm)	Weight (kg)
K	25°	FV50V-2DK.E7.25.G	150325	FV50V-2DK.E7.25.H	150326	460	260	38
	30°	FV50V-2DK.F7.30.G	150329	FV50V-2DK.F7.30.H	150330	460	385	51
	35°	FV50V-2DK.G7.35.G	150273	FV50V-2DK.G7.35.H	150274	540	385	61
	40°	FV50V-2DK.G7.40.G	150333	FV50V-2DK.G7.40.H	150334	540	385	66
	45°	FV50V-2DK.G7.45.G	150281	FV50V-2DK.G7.45.H	150282	540	385	66
F	25°	FV50V-2DF.E7.25.G	150327	FV50V-2DF.E7.25.H	150328	---	470	43
	30°	FV50V-2DF.F7.30.G	150331	FV50V-2DF.F7.30.H	150332	---	540	55
	35°	FV50V-2DF.G7.35.G	150275	FV50V-2DF.G7.35.H	150276	---	540	65
	40°	FV50V-2DF.G7.40.G	150335	FV50V-2DF.G7.40.H	150336	---	540	70
	45°	FV50V-2DF.G7.45.G	150283	FV50V-2DF.G7.45.H	150284	---	540	70

FV50V-4D



50Hz Motor	U	I	P ₂	n	
	V	A	kW	min ⁻¹	
25°	71 M	400	0,77	0,25	1350
30°	71 M	400	1,06	0,37	1370
35°	80 M	400	1,93	0,55	1395
40°	80 M	400	1,91	0,75	1395
45°	90 S	400	2,55	1,1	1415

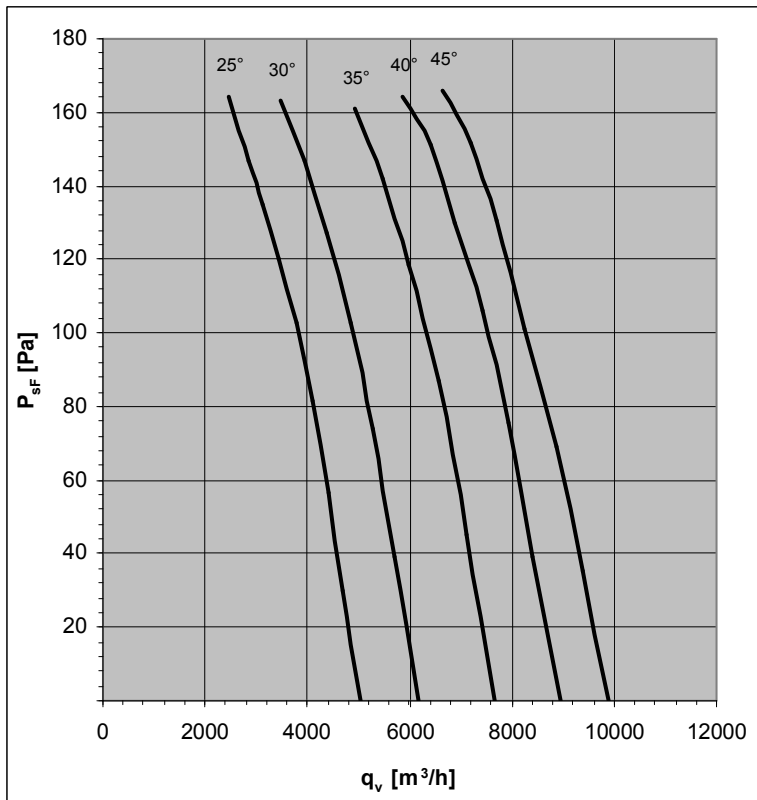

Design K

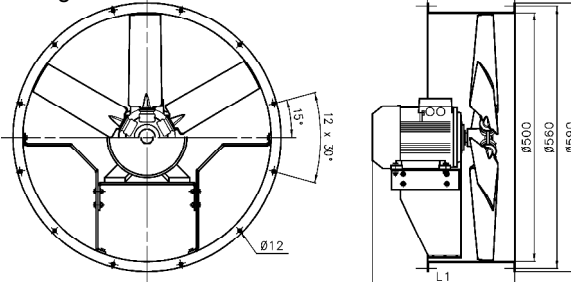

Design F

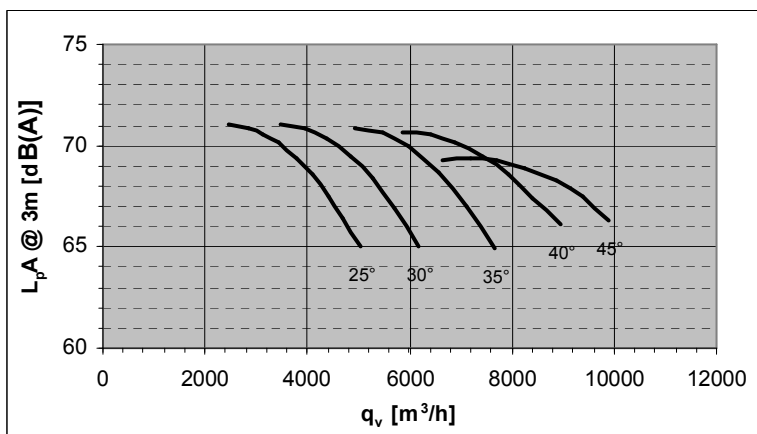
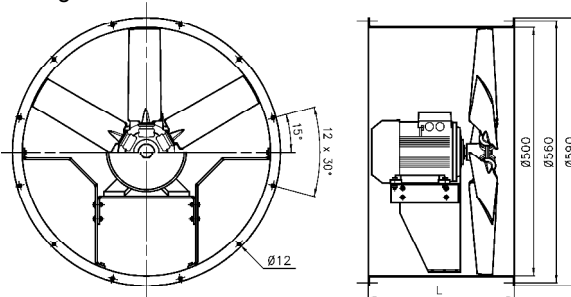

Pitch Angle	Relative spectrum							
	63	125	250	500	1000	2000	4000	8000
25°	-41	-33	-14	-7	-4	-6	-11	-20
30°	-40	-32	-14	-7	-4	-5	-10	-19
35°	-39	-31	-15	-7	-4	-5	-9	-18
40°	-39	-30	-15	-7	-4	-5	-9	-17
45°	-38	-29	-15	-7	-4	-5	-8	-16

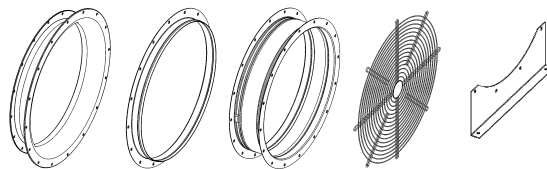

Accessories : see pages 100-102

Design	Pitch Angle	Type (G finish)	Part N°	Type (H finish)	Part N°	L1(mm)	L(mm)	Weight (kg)
K	25°	FV50V-4DK.A7.25.G	150285	FV50V-4DK.A7.25.H	150286	343	260	23
	30°	FV50V-4DK.A7.30.G	150289	FV50V-4DK.A7.30.H	150290	343	260	24
	35°	FV50V-4DK.B7.35.G	150293	FV50V-4DK.B7.35.H	150294	343	260	27
	40°	FV50V-4DK.B7.40.G	150297	FV50V-4DK.B7.40.H	150298	343	260	28
	45°	FV50V-4DK.C7.45.G	150337	FV50V-4DK.C7.45.H	150338	392	260	31
F	25°	FV50V-4DF.A7.25.G	150287	FV50V-4DF.A7.25.H	150288	---	470	28
	30°	FV50V-4DF.A7.30.G	150291	FV50V-4DF.A7.30.H	150292	---	470	29
	35°	FV50V-4DF.B7.35.G	150295	FV50V-4DF.B7.35.H	150296	---	470	32
	40°	FV50V-4DF.B7.40.G	150299	FV50V-4DF.B7.40.H	150300	---	470	33
	45°	FV50V-4DF.C7.45.G	150339	FV50V-4DF.C7.45.H	150340	---	470	36

FV50V-6D

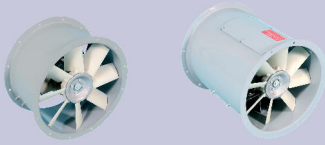

50Hz Motor	U V	I A	P ₂ kW	n min ⁻¹	
25°	63 M	400	0,44	0,09	850
30°	63 M	400	0,44	0,09	850
35°	71 M	400	0,72	0,18	850
40°	71 M	400	0,72	0,18	850
45°	71 M	400	0,72	0,18	850

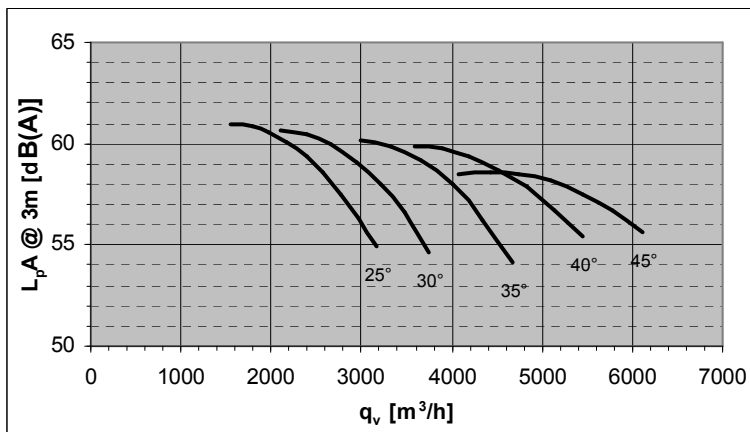
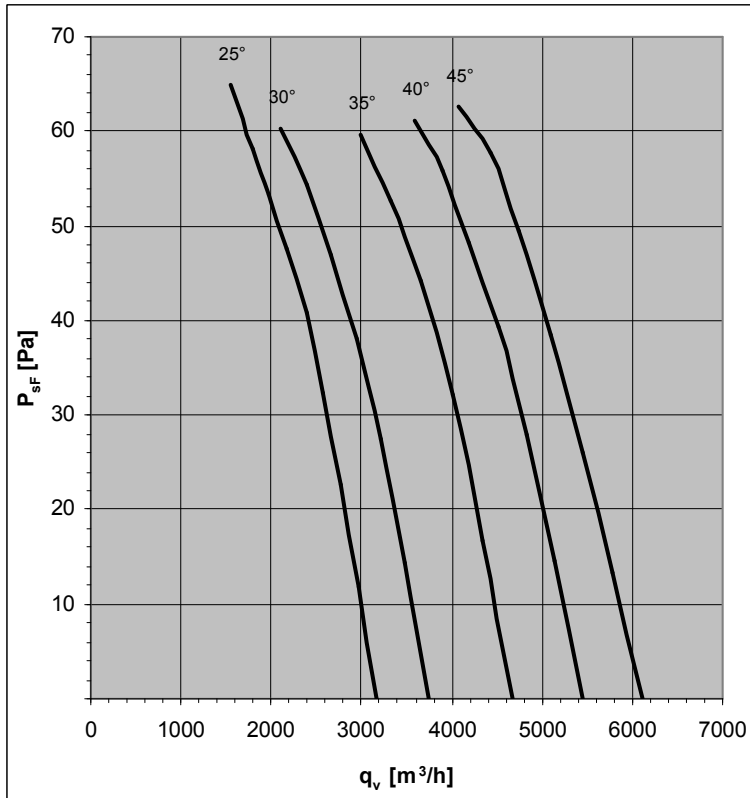

Design K

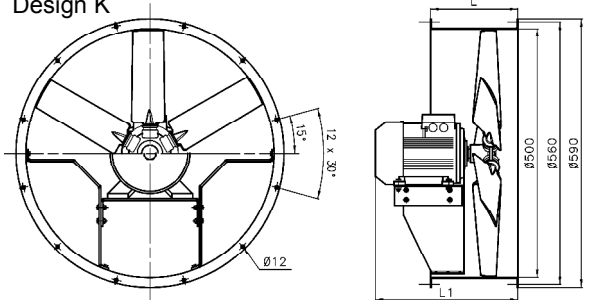

Design F

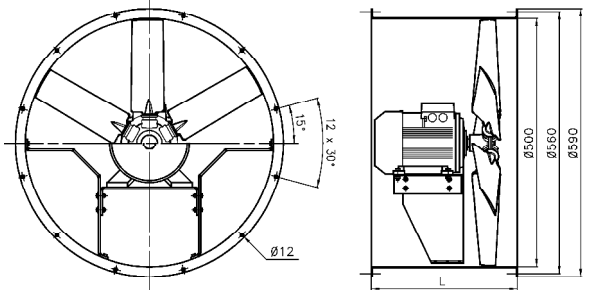

Pitch Angle	Relative spectrum							
	63	125	250	500	1000	2000	4000	8000
25°	-36	-29	-13	-6	-3	-5	-9	-18
30°	-35	-28	-13	-6	-3	-5	-9	-17
35°	-34	-27	-13	-6	-3	-5	-8	-16
40°	-34	-26	-13	-6	-3	-4	-8	-15
45°	-33	-25	-13	-6	-3	-4	-7	-14

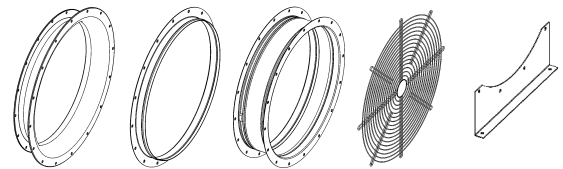

Accessories : see pages 100-102

Design	Pitch Angle	Type (G finish)	Part N°	Type (H finish)	Part N°	L1(mm)	L(mm)	Weight (kg)
K	25°	FV50V-6DK.97.25.G	150305	FV50V-6DK.97.25.H	150306	343	260	22
	30°	FV50V-6DK.97.30.G	150309	FV50V-6DK.97.30.H	150310	343	260	22
	35°	FV50V-6DK.A7.35.G	150313	FV50V-6DK.A7.35.H	150314	343	260	23
	40°	FV50V-6DK.A7.40.G	150317	FV50V-6DK.A7.40.H	150318	343	260	23
	45°	FV50V-6DK.A7.45.G	150321	FV50V-6DK.A7.45.H	150322	343	260	23
F	25°	FV50V-6DF.97.25.G	150307	FV50V-6DF.97.25.H	150308	---	470	27
	30°	FV50V-6DF.97.30.G	150311	FV50V-6DF.97.30.H	150312	---	470	27
	35°	FV50V-6DF.A7.35.G	150315	FV50V-6DF.A7.35.H	150316	---	470	28
	40°	FV50V-6DF.A7.40.G	150319	FV50V-6DF.A7.40.H	150320	---	470	28
	45°	FV50V-6DF.A7.45.G	150323	FV50V-6DF.A7.45.H	150324	---	470	28

FV56V-4D



50Hz Motor	U	I	P ₂	n	
	V	A	kW	min ⁻¹	
30°	80 M	400	1,93	0,55	1395
35°	80 M	400	1,91	0,75	1395
40°	90 S	400	2,55	1,1	1415
45°	90 L	400	3,4	1,5	1420
50°	90 L	400	3,4	1,5	1420

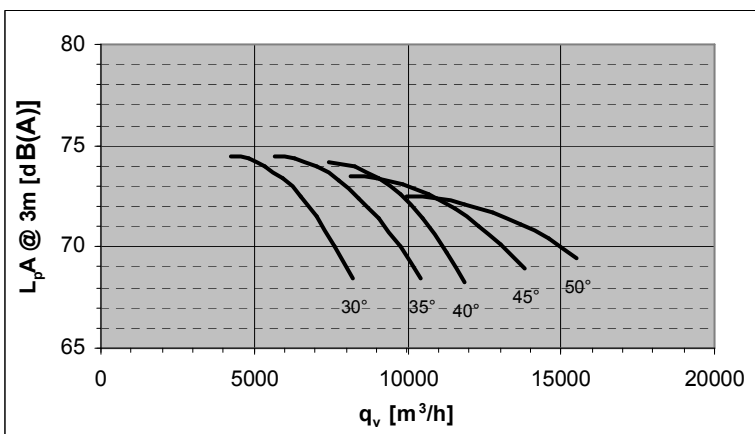
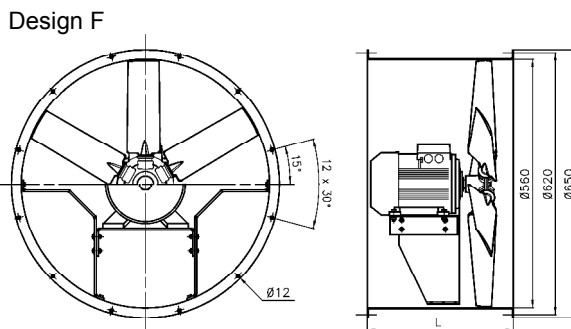
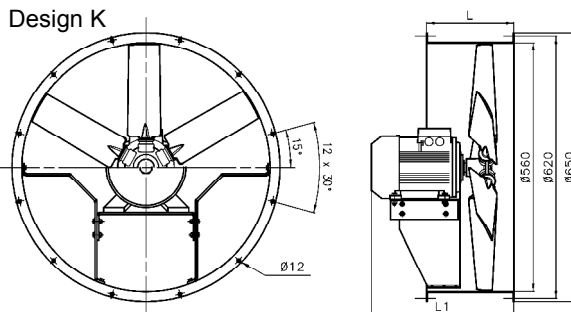
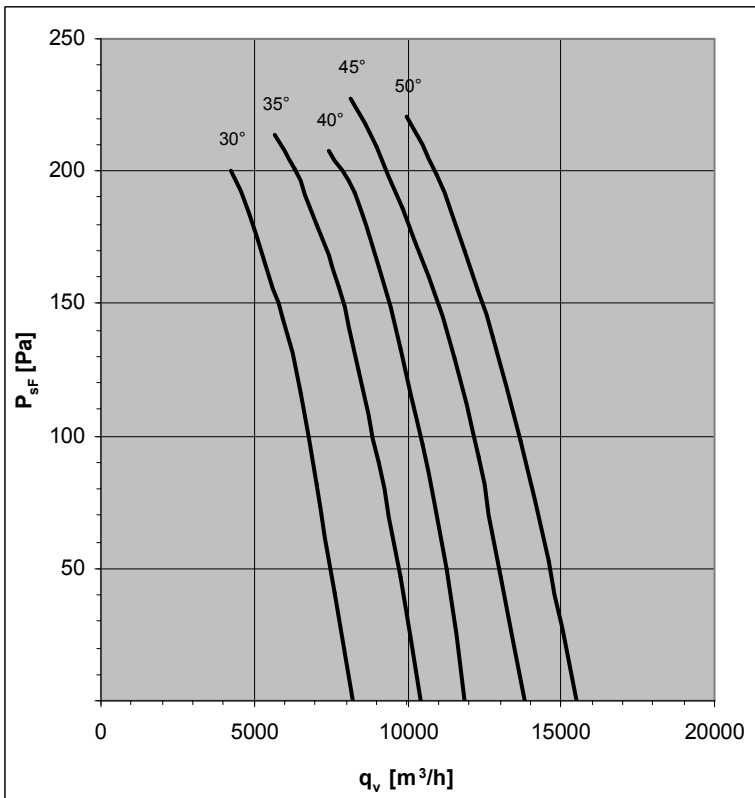

Pitch Angle	Relative spectrum							
	63	125	250	500	1000	2000	4000	8000
30°	-43	-34	-15	-7	-4	-6	-11	-21
35°	-42	-33	-15	-7	-4	-6	-10	-20
40°	-41	-32	-15	-7	-4	-5	-10	-19
45°	-40	-31	-15	-8	-4	-5	-9	-18
50°	-39	-30	-16	-8	-4	-5	-8	-17

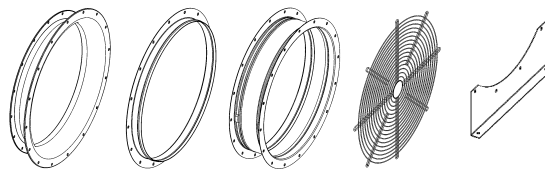

Accessories : see pages 100-102

Design	Pitch Angle	Type (G finish)	Part N°	Type (H finish)	Part N°	L1(mm)	L(mm)	Weight (kg)
K	30°	FV56V-4DK.B7.30.G	150341	FV56V-4DK.B7.30.H	150342	343	260	29
	35°	FV56V-4DK.B7.35.G	150345	FV56V-4DK.B7.35.H	150346	343	260	30
	40°	FV56V-4DK.C7.40.G	150349	FV56V-4DK.C7.40.H	150350	392	260	33
	45°	FV56V-4DK.D7.45.G	150381	FV56V-4DK.D7.45.H	150382	392	260	35
	50°	FV56V-4DK.D7.50.G	150357	FV56V-4DK.D7.50.H	150358	392	260	35
F	30°	FV56V-4DF.B7.30.G	150343	FV56V-4DF.B7.30.H	150344	---	470	35
	35°	FV56V-4DF.B7.35.G	150347	FV56V-4DF.B7.35.H	150348	---	470	36
	40°	FV56V-4DF.C7.40.G	150351	FV56V-4DF.C7.40.H	150352	---	470	39
	45°	FV56V-4DF.D7.45.G	150383	FV56V-4DF.D7.45.H	150384	---	470	42
	50°	FV56V-4DF.D7.50.G	150359	FV56V-4DF.D7.50.H	150360	---	470	42

FV56V-6D

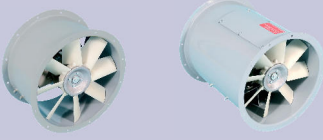

50Hz Motor	U V	I A	P ₂ kW	n min ⁻¹	
30°	71 M	400	0,72	0,18	850
35°	71 M	400	0,72	0,18	850
40°	71 M	400	0,79	0,25	830
45°	80 M	400	1,2	0,37	920
50°	80 M	400	1,6	0,55	910

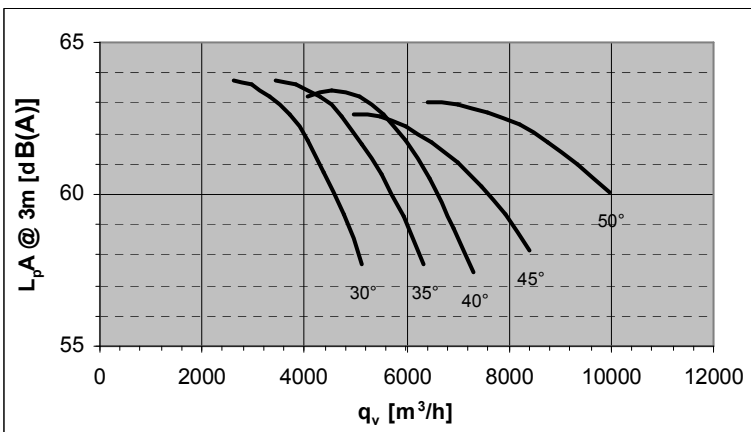
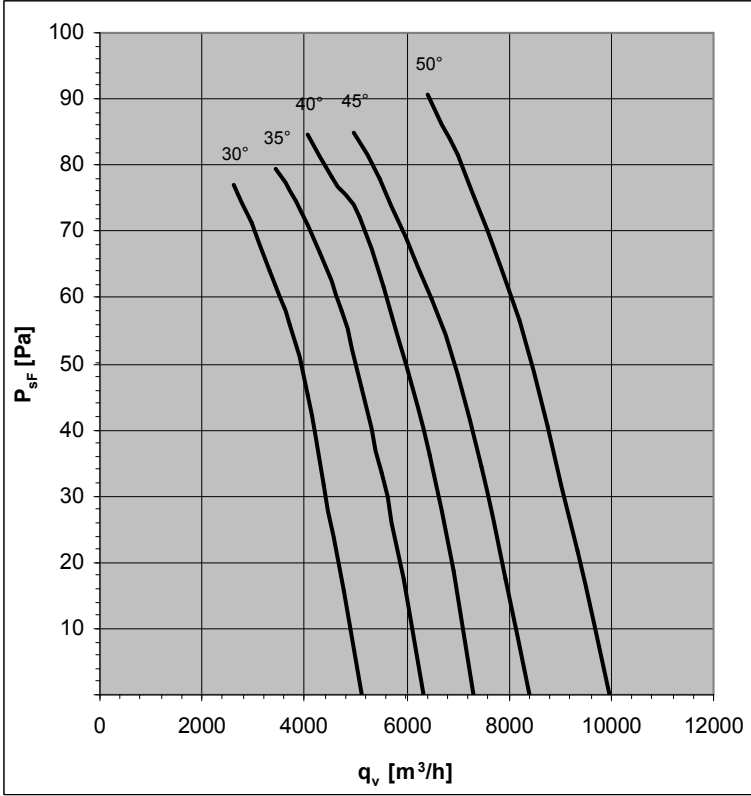

Design K

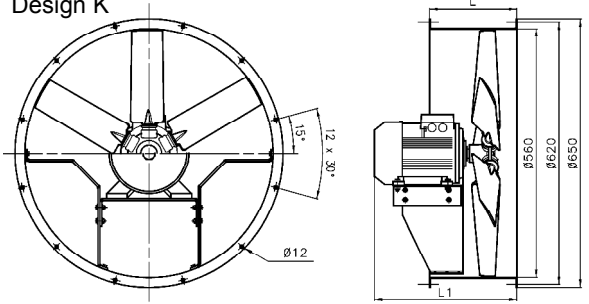

Design F

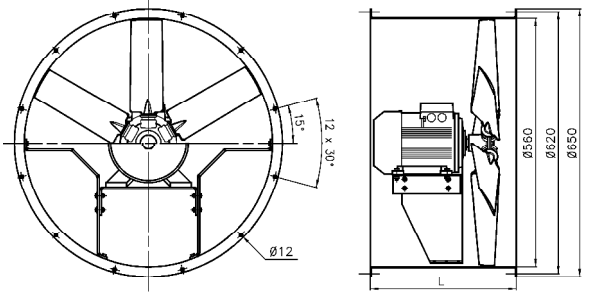

Pitch Angle	Relative spectrum							
	63	125	250	500	1000	2000	4000	8000
30°	-38	-30	-13	-6	-4	-5	-10	-18
35°	-37	-29	-13	-6	-3	-5	-9	-17
40°	-36	-28	-13	-6	-3	-5	-8	-16
45°	-35	-27	-13	-7	-3	-5	-8	-15
50°	-35	-27	-14	-7	-4	-5	-8	-15

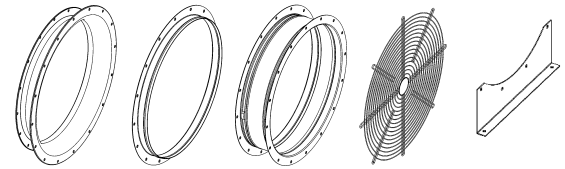

Accessories : see pages 100-102

Design	Pitch Angle	Type (G finish)	Part N°	Type (H finish)	Part N°	L1(mm)	L(mm)	Weight (kg)
K	30°	FV56V-6DK.A7.30.G	150361	FV56V-6DK.A7.30.H	150362	343	260	25
	35°	FV56V-6DK.A7.35.G	150365	FV56V-6DK.A7.35.H	150366	343	260	25
	40°	FV56V-6DK.A7.40.G	150369	FV56V-6DK.A7.40.H	150370	343	260	26
	45°	FV56V-6DK.B7.45.G	150385	FV56V-6DK.B7.45.H	150386	343	260	29
	50°	FV56V-6DK.B7.50.G	150389	FV56V-6DK.B7.50.H	150390	343	260	30
F	30°	FV56V-6DF.A7.30.G	150363	FV56V-6DF.A7.30.H	150364	---	470	31
	35°	FV56V-6DF.A7.35.G	150367	FV56V-6DF.A7.35.H	150368	---	470	31
	40°	FV56V-6DF.A7.40.G	150371	FV56V-6DF.A7.40.H	150372	---	470	32
	45°	FV56V-6DF.B7.45.G	150387	FV56V-6DF.B7.45.H	150388	---	470	35
	50°	FV56V-6DF.B7.50.G	150391	FV56V-6DF.B7.50.H	150392	---	470	36

FV63V-4D

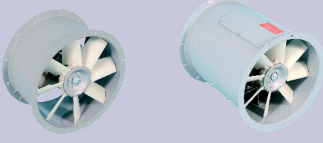

50Hz Motor	U	I	P ₂	n	
	V	A	kW	min ⁻¹	
30°	90 S	400	2,55	1,1	1415
35°	90 L	400	3,4	1,5	1420
40°	100 L	400	4,85	2,2	1425
45°	100 L	400	4,85	2,2	1425
50°	100 L	400	6,2	3	1425

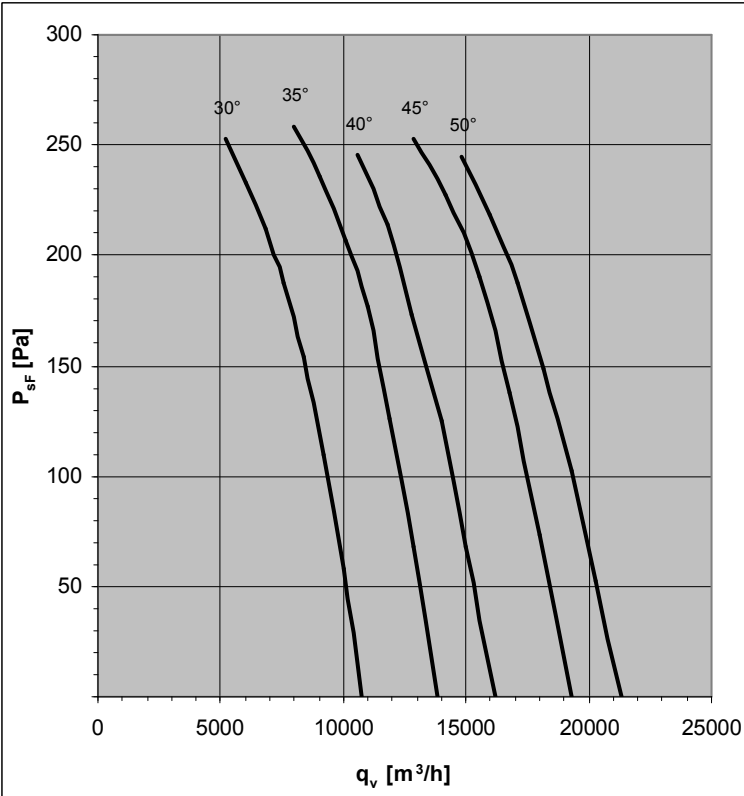

Design K

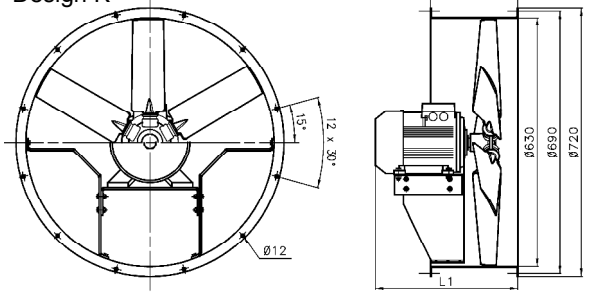

Design F

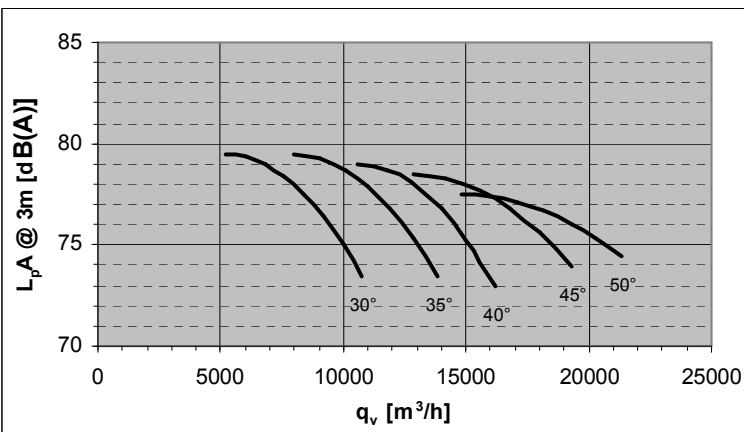
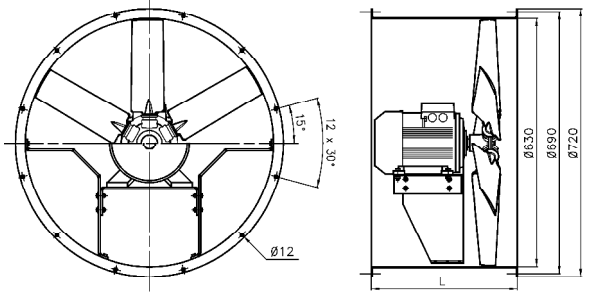

Pitch Angle	Relative spectrum							
	63	125	250	500	1000	2000	4000	8000
30°	-46	-36	-16	-8	-4	-6	-12	-22
35°	-44	-35	-16	-8	-4	-6	-11	-21
40°	-43	-34	-16	-8	-4	-6	-10	-20
45°	-42	-33	-16	-8	-4	-6	-10	-19
50°	-41	-32	-17	-8	-4	-5	-9	-18

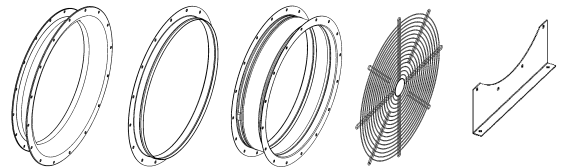

Accessories : see pages 100-102

Design	Pitch Angle	Type (G finish)	Part N°	Type (H finish)	Part N°	L1(mm)	L(mm)	Weight (kg)
K	30°	FV63V-4DK.C7.30.G	150393	FV63V-4DK.C7.30.H	150394	392	260	35
	35°	FV63V-4DK.D7.35.G	150397	FV63V-4DK.D7.35.H	150398	392	260	38
	40°	FV63V-4DK.E7.40.G	150453	FV63V-4DK.E7.40.H	150454	460	260	40
	45°	FV63V-4DK.E7.45.G	150405	FV63V-4DK.E7.45.H	150406	460	260	40
	50°	FV63V-4DK.E7.50.G	150409	FV63V-4DK.E7.50.H	150410	460	260	44
F	30°	FV63V-4DF.C7.30.G	150395	FV63V-4DF.C7.30.H	150396	---	470	43
	35°	FV63V-4DF.D7.35.G	150399	FV63V-4DF.D7.35.H	150400	---	470	45
	40°	FV63V-4DF.E7.40.G	150455	FV63V-4DF.E7.40.H	150456	---	470	48
	45°	FV63V-4DF.E7.45.G	150407	FV63V-4DF.E7.45.H	150408	---	470	48
	50°	FV63V-4DF.E7.50.G	150411	FV63V-4DF.E7.50.H	150412	---	470	52

Increased Temperature Range : -30°C / +60°C

FV63V-6D

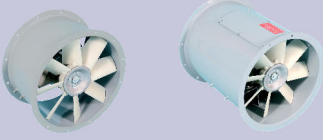

50Hz Motor	U	I	P ₂	n	
	V	A	kW	min ⁻¹	
30°	71 M	400	0,79	0,25	830
35°	80 M	400	1,2	0,37	920
40°	80 M	400	1,6	0,55	910
45°	90 S	400	2,05	0,75	915
50°	90 S	400	2,05	0,75	915

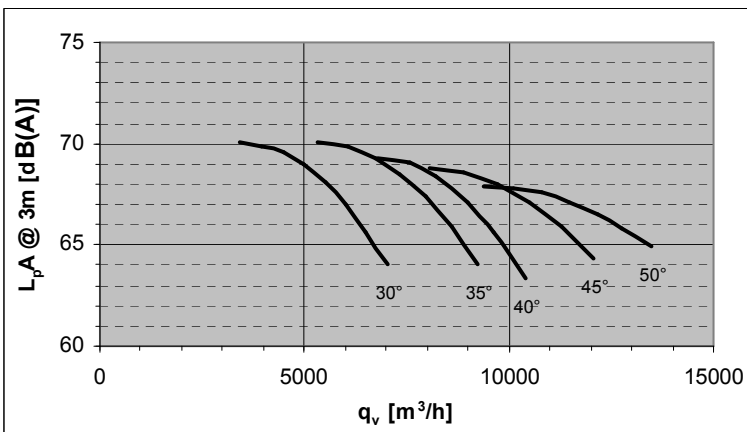
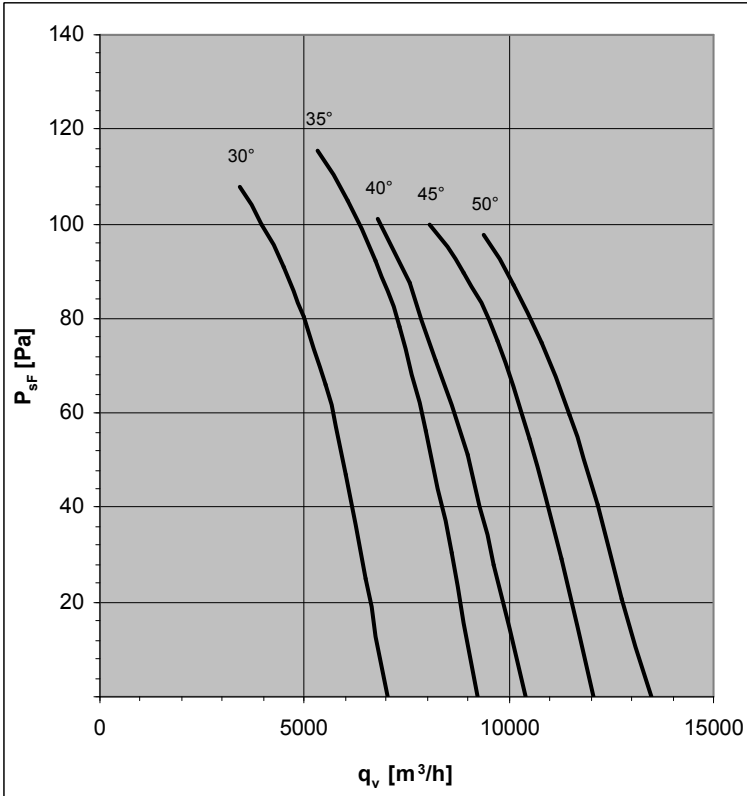

Design K

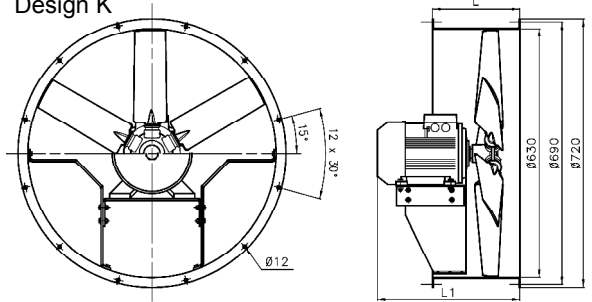

Design F

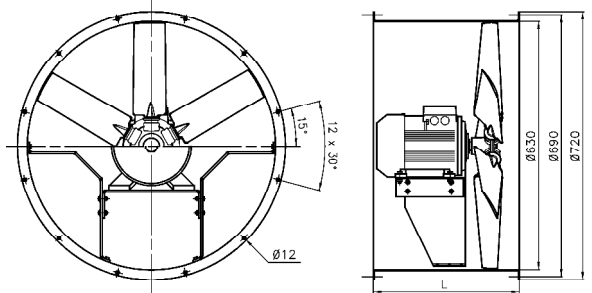

Pitch Angle	Relative spectrum							
	63	125	250	500	1000	2000	4000	8000
30°	-41	-32	-14	-7	-4	-6	-10	-20
35°	-40	-31	-14	-7	-4	-5	-10	-19
40°	-38	-30	-14	-7	-4	-5	-9	-17
45°	-38	-29	-15	-7	-4	-5	-9	-17
50°	-37	-29	-15	-7	-4	-5	-8	-16

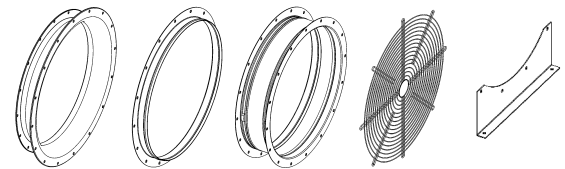

Accessories : see pages 100-102

Design	Pitch Angle	Type (G finish)	Part N°	Type (H finish)	Part N°	L1(mm)	L(mm)	Weight (kg)
K	30°	FV63V-6DK.A7.30.G	150413	FV63V-6DK.A7.30.H	150414	343	260	28
	35°	FV63V-6DK.B7.35.G	150417	FV63V-6DK.B7.35.H	150418	343	260	31
	40°	FV63V-6DK.B7.40.G	150421	FV63V-6DK.B7.40.H	150422	343	260	32
	45°	FV63V-6DK.C7.45.G	150457	FV63V-6DK.C7.45.H	150458	392	260	35
	50°	FV63V-6DK.C7.50.G	150429	FV63V-6DK.C7.50.H	150430	392	260	35
F	30°	FV63V-6DF.A7.30.G	150415	FV63V-6DF.A7.30.H	150416	---	470	36
	35°	FV63V-6DF.B7.35.G	150419	FV63V-6DF.B7.35.H	150420	---	470	39
	40°	FV63V-6DF.B7.40.G	150423	FV63V-6DF.B7.40.H	150424	---	470	40
	45°	FV63V-6DF.C7.45.G	150459	FV63V-6DF.C7.45.H	150460	---	470	43
	50°	FV63V-6DF.C7.50.G	150431	FV63V-6DF.C7.50.H	150432	---	470	43

FV63V-8D

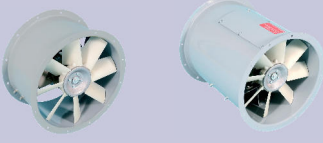

50Hz Motor	U	I	P ₂	n	
	V	A	kW	min ⁻¹	
30°	71 M	400	0,36	0,09	630
35°	71 M	400	0,51	0,12	645
40°	80 M	400	0,75	0,18	675
45°	80 M	400	1,02	0,25	685
50°	90 S	400	1,14	0,37	675

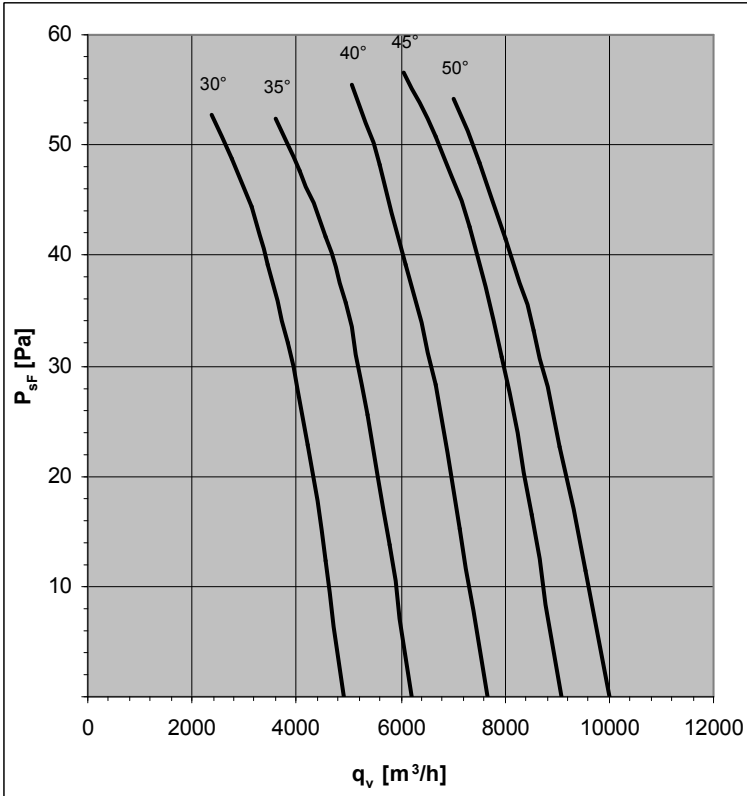

Design K

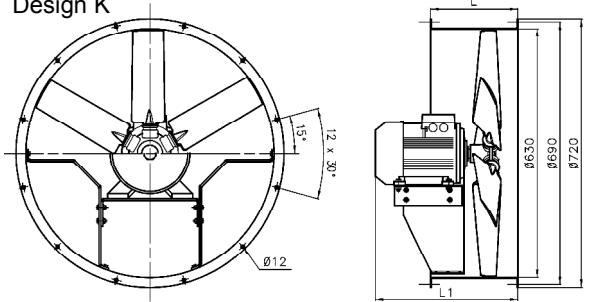

Design F

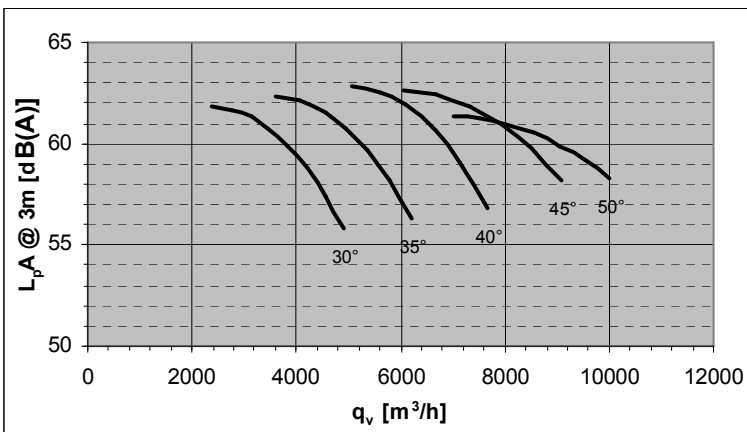
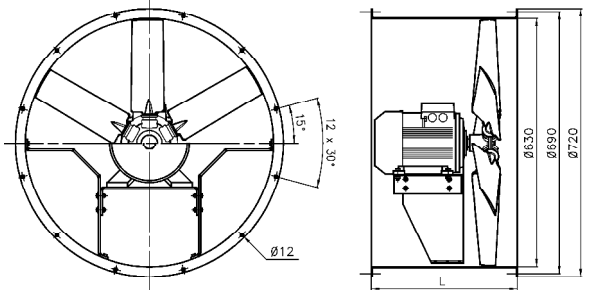

Pitch Angle	Relative spectrum							
	63	125	250	500	1000	2000	4000	8000
30°	-37	-29	-13	-6	-3	-5	-9	-18
35°	-36	-28	-13	-6	-3	-5	-9	-17
40°	-35	-28	-13	-6	-3	-5	-8	-16
45°	-35	-27	-13	-7	-3	-5	-8	-15
50°	-34	-26	-14	-7	-3	-4	-7	-14

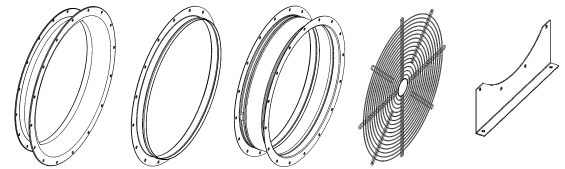

Accessories : see pages 100-102

Design	Pitch Angle	Type (G finish)	Part N°	Type (H finish)	Part N°	L1(mm)	L(mm)	Weight (kg)
K	30°	FV63V-8DK.A7.30.G	150433	FV63V-8DK.A7.30.H	150434	343	260	28
	35°	FV63V-8DK.A7.35.G	150437	FV63V-8DK.A7.35.H	150438	343	260	28
	40°	FV63V-8DK.B7.40.G	150441	FV63V-8DK.B7.40.H	150442	343	260	31
	45°	FV63V-8DK.B7.45.G	150445	FV63V-8DK.B7.45.H	150446	343	260	32
	50°	FV63V-8DK.C7.50.G	150461	FV63V-8DK.C7.50.H	150462	392	260	33
F	30°	FV63V-8DF.A7.30.G	150435	FV63V-8DF.A7.30.H	150436	---	470	36
	35°	FV63V-8DF.A7.35.G	150439	FV63V-8DF.A7.35.H	150440	---	470	36
	40°	FV63V-8DF.B7.40.G	150443	FV63V-8DF.B7.40.H	150444	---	470	39
	45°	FV63V-8DF.B7.45.G	150447	FV63V-8DF.B7.45.H	150448	---	470	40
	50°	FV63V-8DF.C7.50.G	150463	FV63V-8DF.C7.50.H	150464	---	470	41

FV71V-4D

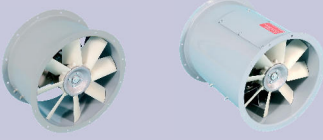

50Hz Motor	U	I	P ₂	n	
	V	A	kW	min ⁻¹	
25°	90 L	400	3,4	1,5	1420
30°	100 L	400	4,85	2,2	1425
35°	100 L	400	6,2	3	1425
40°	112 M	400	8,2	4	1435
45°	132 S	400	11,2	5,5	1450

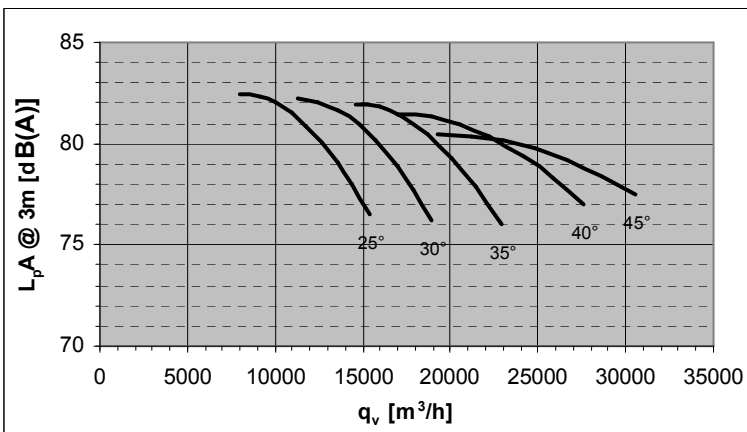
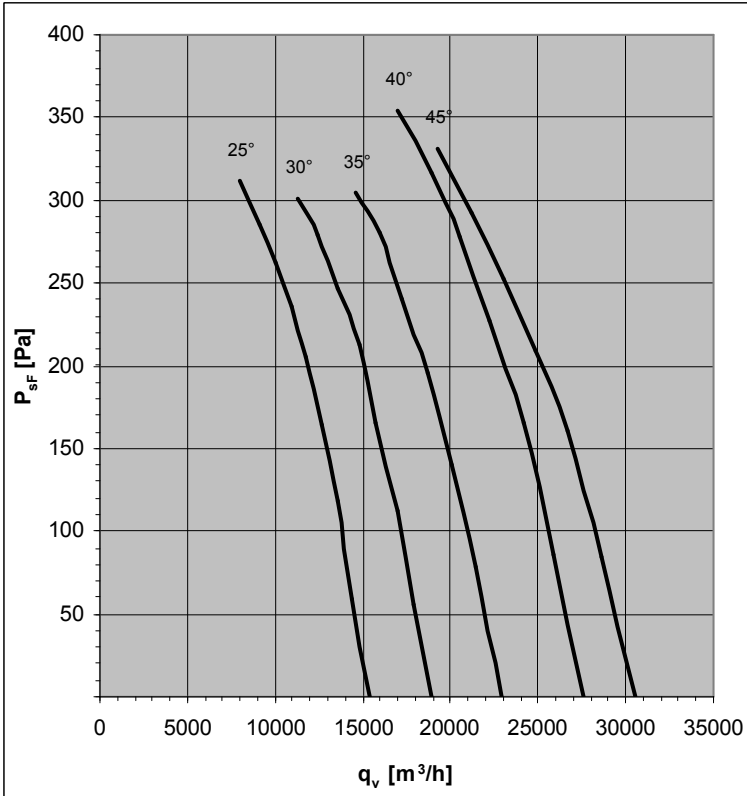

Design K

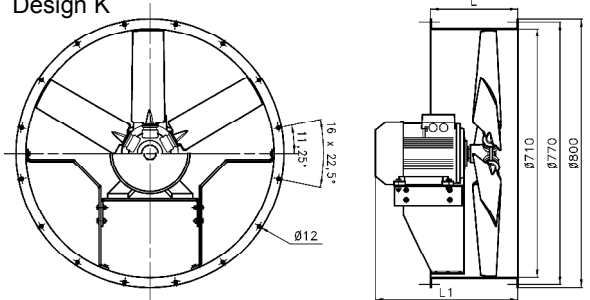

Design F

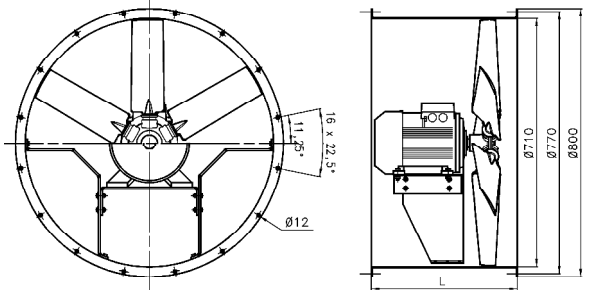

Pitch Angle	Relative spectrum							
	63	125	250	500	1000	2000	4000	8000
25°	-47	-37	-16	-8	-4	-6	-12	-23
30°	-46	-36	-16	-8	-4	-6	-11	-21
35°	-44	-35	-17	-8	-4	-6	-10	-20
40°	-44	-34	-17	-8	-4	-6	-10	-19
45°	-43	-33	-17	-8	-4	-6	-9	-18

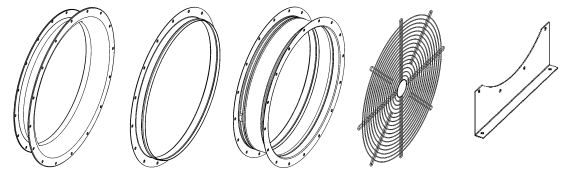

Accessories : see pages 100-102

Design	Pitch Angle	Type (G finish)	Part N°	Type (H finish)	Part N°	L1(mm)	L(mm)	Weight (kg)
K	25°	FV71V-4DK.D7.25.G	150465	FV71V-4DK.D7.25.H	150466	413	280	43
	30°	FV71V-4DK.E7.30.G	150469	FV71V-4DK.E7.30.H	150470	485	280	45
	35°	FV71V-4DK.E7.35.G	150473	FV71V-4DK.E7.35.H	150474	485	280	49
	40°	FV71V-4DK.F7.40.G	150477	FV71V-4DK.F7.40.H	150478	482	400	64
	45°	FV71V-4DK.G7.45.G	150525	FV71V-4DK.G7.45.H	150526	560	400	75
F	25°	FV71V-4DF.D7.25.G	150467	FV71V-4DF.D7.25.H	150468	---	500	52
	30°	FV71V-4DF.E7.30.G	150471	FV71V-4DF.E7.30.H	150472	---	500	55
	35°	FV71V-4DF.E7.35.G	150475	FV71V-4DF.E7.35.H	150476	---	500	59
	40°	FV71V-4DF.F7.40.G	150479	FV71V-4DF.F7.40.H	150480	---	560	71
	45°	FV71V-4DF.G7.45.G	150527	FV71V-4DF.G7.45.H	150528	---	560	82

FV71V-6D

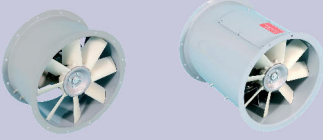

50Hz Motor	U	I	P ₂	n	
	V	A	kW	min ⁻¹	
25°	80 M	400	1,6	0,55	910
30°	80 M	400	1,6	0,55	910
35°	90 S	400	2,05	0,75	915
40°	90 L	400	2,85	1,1	915
45°	90 L	400	2,85	1,1	915

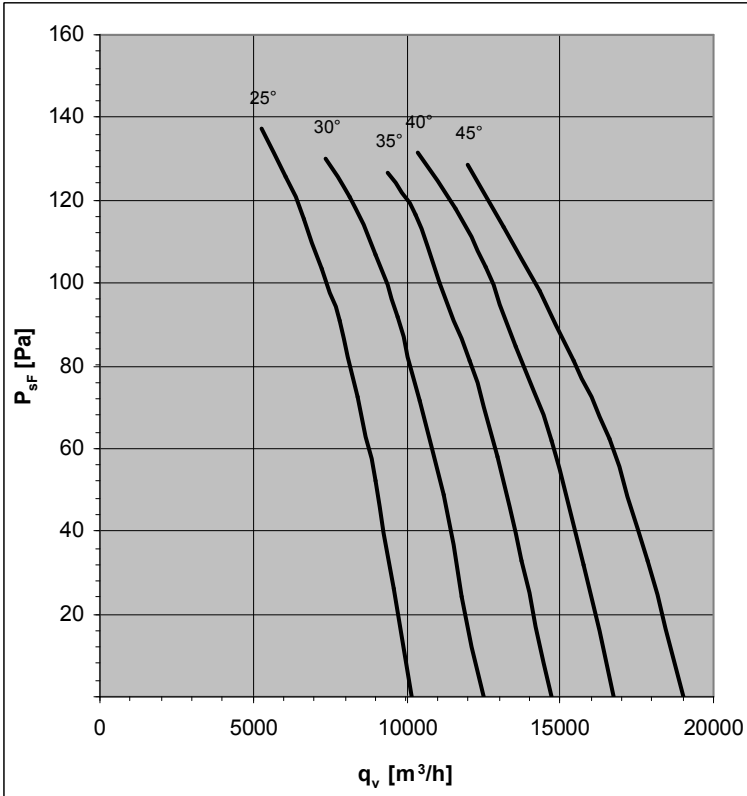

Design K

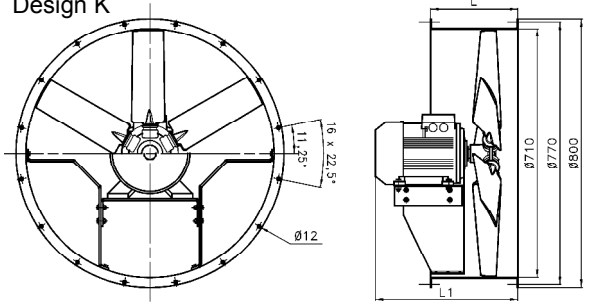

Design F

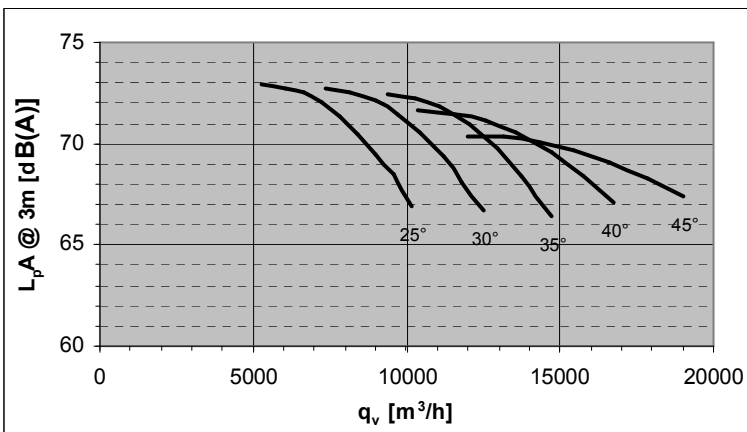
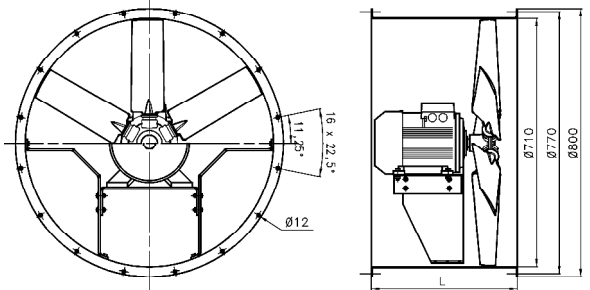

Pitch Angle	Relative spectrum							
	63	125	250	500	1000	2000	4000	8000
25°	-42	-33	-15	-7	-4	-6	-11	-20
30°	-41	-32	-15	-7	-4	-6	-10	-19
35°	-40	-31	-15	-7	-4	-5	-9	-18
40°	-39	-30	-15	-7	-4	-5	-9	-17
45°	-38	-30	-15	-7	-4	-5	-8	-16

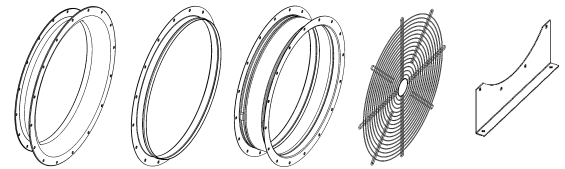

Accessories : see pages 100-102

Design	Pitch Angle	Type (G finish)	Part N°	Type (H finish)	Part N°	L1(mm)	L(mm)	Weight (kg)
K	25°	FV71V-6DK.B7.25.G	150529	FV71V-6DK.B7.25.H	150530	365	280	37
	30°	FV71V-6DK.B7.30.G	150489	FV71V-6DK.B7.30.H	150490	365	280	37
	35°	FV71V-6DK.C7.35.G	150493	FV71V-6DK.C7.35.H	150494	413	280	40
	40°	FV71V-6DK.D7.40.G	150497	FV71V-6DK.D7.40.H	150498	413	280	43
	45°	FV71V-6DK.D7.45.G	150501	FV71V-6DK.D7.45.H	150502	413	280	43
F	25°	FV71V-6DF.B7.25.G	150531	FV71V-6DF.B7.25.H	150532	---	500	47
	30°	FV71V-6DF.B7.30.G	150491	FV71V-6DF.B7.30.H	150492	---	500	47
	35°	FV71V-6DF.C7.35.G	150495	FV71V-6DF.C7.35.H	150496	---	500	50
	40°	FV71V-6DF.D7.40.G	150499	FV71V-6DF.D7.40.H	150500	---	500	53
	45°	FV71V-6DF.D7.45.G	150503	FV71V-6DF.D7.45.H	150504	---	500	53

FV71V-8D

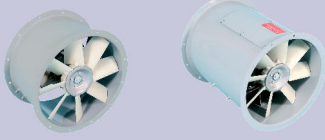

50Hz Motor	U	I	P ₂	n	
	V	A	kW	min ⁻¹	
25°	80 M	400	0,75	0,18	675
30°	80 M	400	1,02	0,25	685
35°	90 S	400	1,14	0,37	675
40°	90 S	400	1,14	0,37	675
45°	90 L	400	1,58	0,55	675

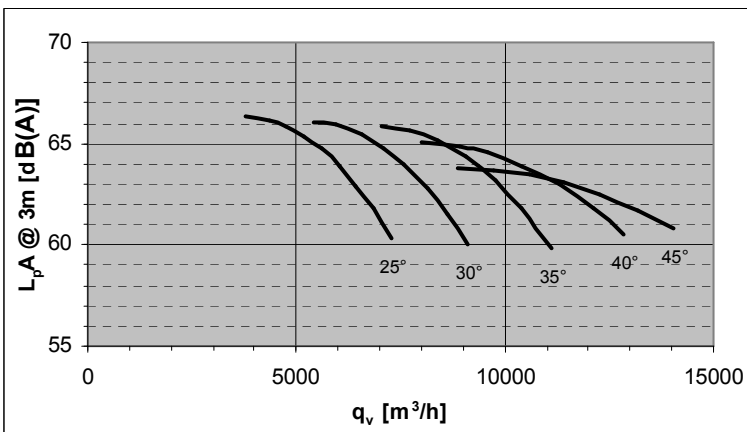
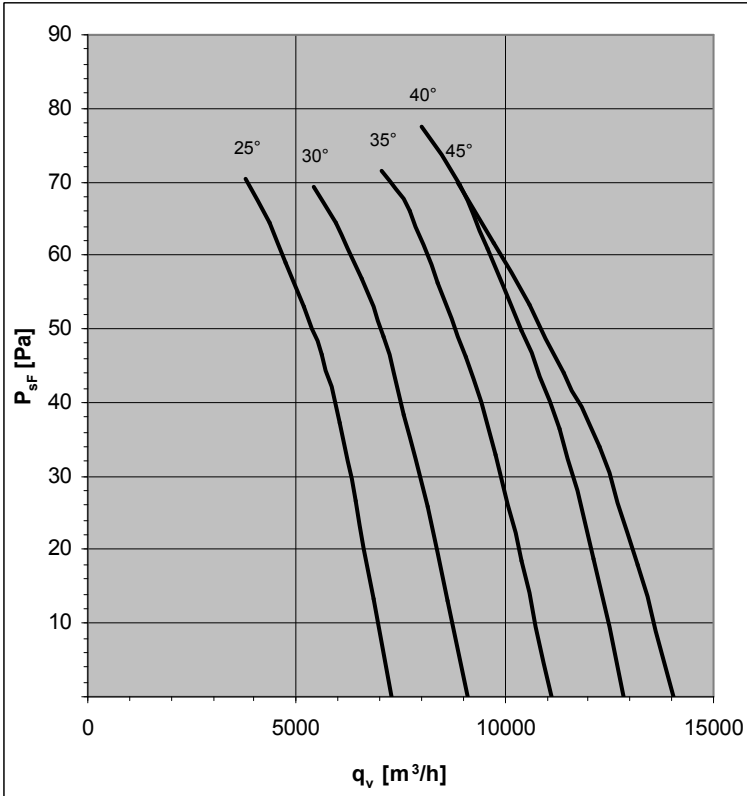

Design K

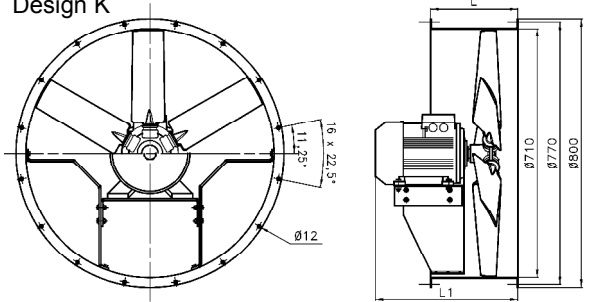

Design F

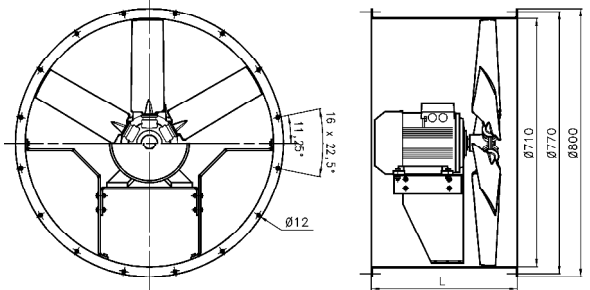

Pitch Angle	Relative spectrum							
	63	125	250	500	1000	2000	4000	8000
25°	-39	-31	-13	-7	-4	-5	-10	-19
30°	-38	-30	-14	-7	-4	-5	-9	-18
35°	-37	-29	-14	-7	-4	-5	-9	-17
40°	-36	-28	-14	-7	-4	-5	-8	-16
45°	-35	-27	-14	-7	-4	-5	-8	-15

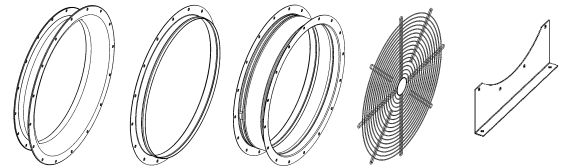

Accessories : see pages 100-102

Design	Pitch Angle	Type (G finish)	Part N°	Type (H finish)	Part N°	L1(mm)	L(mm)	Weight (kg)
K	25°	FV71V-8DK.B7.25.G	150505	FV71V-8DK.B7.25.H	150506	365	280	36
	30°	FV71V-8DK.B7.30.G	150509	FV71V-8DK.B7.30.H	150510	365	280	37
	35°	FV71V-8DK.C7.35.G	150513	FV71V-8DK.C7.35.H	150514	413	280	38
	40°	FV71V-8DK.C7.40.G	150517	FV71V-8DK.C7.40.H	150518	413	280	38
	45°	FV71V-8DK.D7.45.G	150521	FV71V-8DK.D7.45.H	150522	413	280	40
F	25°	FV71V-8DF.B7.25.G	150507	FV71V-8DF.B7.25.H	150508	---	500	46
	30°	FV71V-8DF.B7.30.G	150511	FV71V-8DF.B7.30.H	150512	---	500	47
	35°	FV71V-8DF.C7.35.G	150515	FV71V-8DF.C7.35.H	150516	---	500	48
	40°	FV71V-8DF.C7.40.G	150519	FV71V-8DF.C7.40.H	150520	---	500	48
	45°	FV71V-8DF.D7.45.G	150523	FV71V-8DF.D7.45.H	150524	---	500	50

FV80V-4D

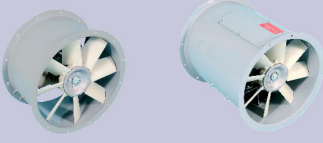

50Hz Motor	U	I	P ₂	n	
	V	A	kW	min ⁻¹	
25°	100 L	400	4,85	2,2	1425
30°	100 L	400	6,2	3	1425
35°	132 S	400	11,2	5,5	1450
40°	132 M	400	15	7,5	1450
45°	132 M	400	15	7,5	1450

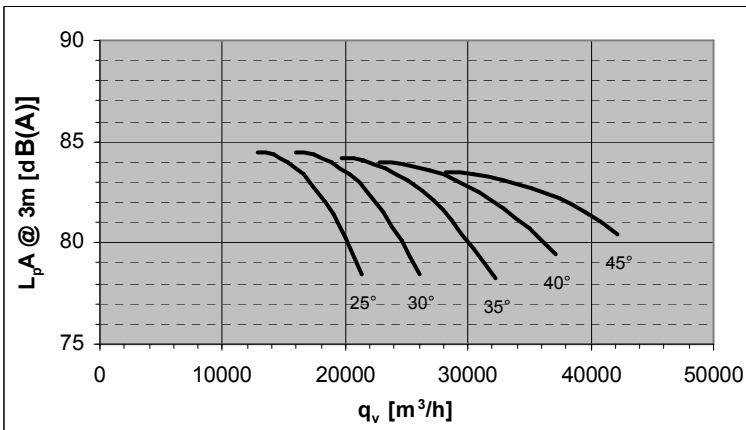
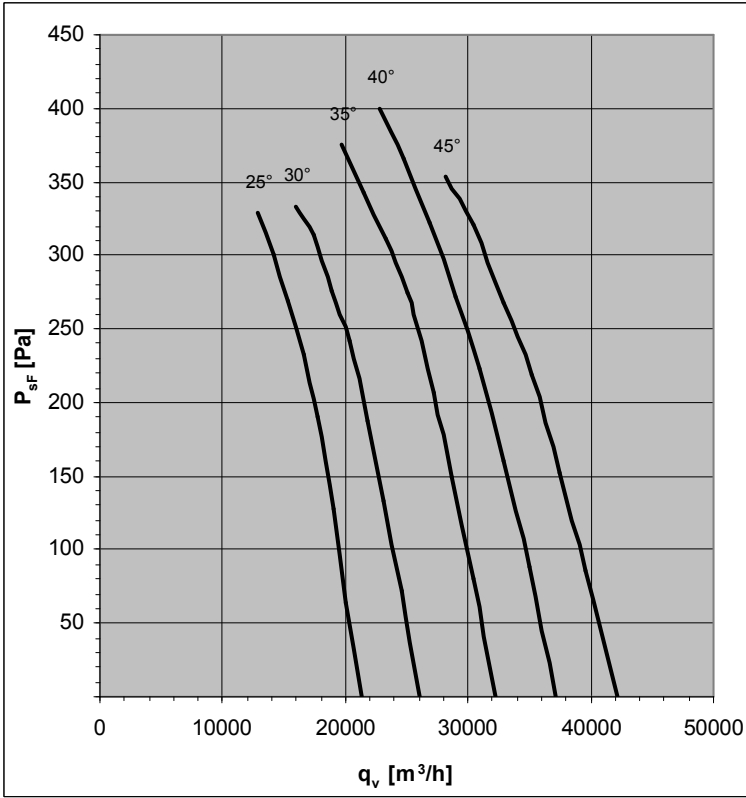

Design K

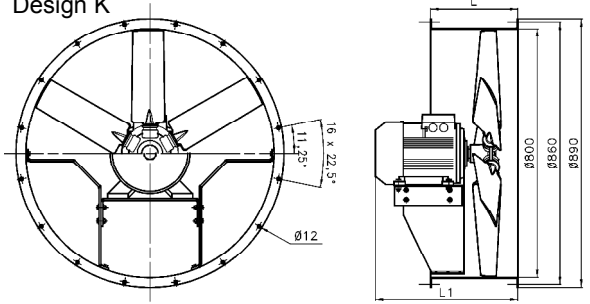

Design F

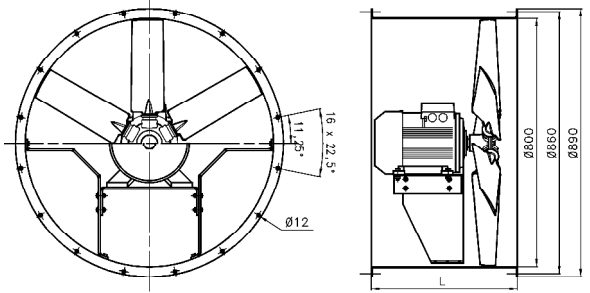

Pitch Angle	Relative spectrum							
	63	125	250	500	1000	2000	4000	8000
25°	-48	-38	-17	-8	-4	-7	-12	-23
30°	-47	-37	-17	-8	-4	-6	-12	-22
35°	-45	-36	-17	-8	-4	-6	-11	-21
40°	-45	-35	-17	-8	-4	-6	-10	-20
45°	-44	-34	-18	-9	-4	-6	-9	-19

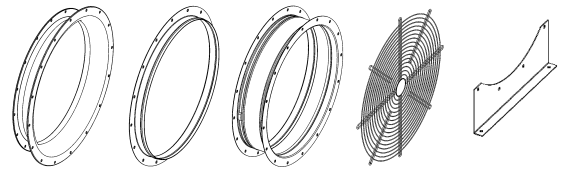

Accessories : see pages 100-102

Design	Pitch Angle	Type (G finish)	Part N°	Type (H finish)	Part N°	L1(mm)	L(mm)	Weight (kg)
K	25°	FV80V-4DK.E7.25.G	150533	FV80V-4DK.E7.25.H	150534	485	280	53
	30°	FV80V-4DK.E7.30.G	150537	FV80V-4DK.E7.30.H	150538	485	280	57
	35°	FV80V-4DK.G7.35.G	150593	FV80V-4DK.G7.35.H	150594	560	400	85
	40°	FV80V-4DK.H7.40.G	150597	FV80V-4DK.H7.40.H	150598	560	400	91
	45°	FV80V-4DK.H7.45.G	150549	FV80V-4DK.H7.45.H	150550	560	400	91
F	25°	FV80V-4DF.E7.25.G	150535	FV80V-4DF.E7.25.H	150536	---	500	65
	30°	FV80V-4DF.E7.30.G	150539	FV80V-4DF.E7.30.H	150540	---	500	69
	35°	FV80V-4DF.G7.35.G	150595	FV80V-4DF.G7.35.H	150596	---	700	102
	40°	FV80V-4DF.H7.40.G	150599	FV80V-4DF.H7.40.H	150600	---	700	108
	45°	FV80V-4DF.H7.45.G	150551	FV80V-4DF.H7.45.H	150552	---	700	108

Increased Temperature Range : -30°C / +60°C

FV80V-6D

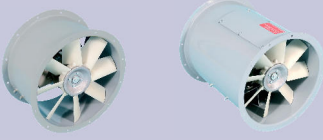

50Hz Motor	U	I	P ₂	n	
	V	A	kW	min ⁻¹	
25°	80 M	400	1,6	0,55	910
30°	90 L	400	2,85	1,1	915
35°	100 L	400	3,8	1,5	940
40°	100 L	400	3,8	1,5	940
45°	112 M	400	5,3	2,2	930

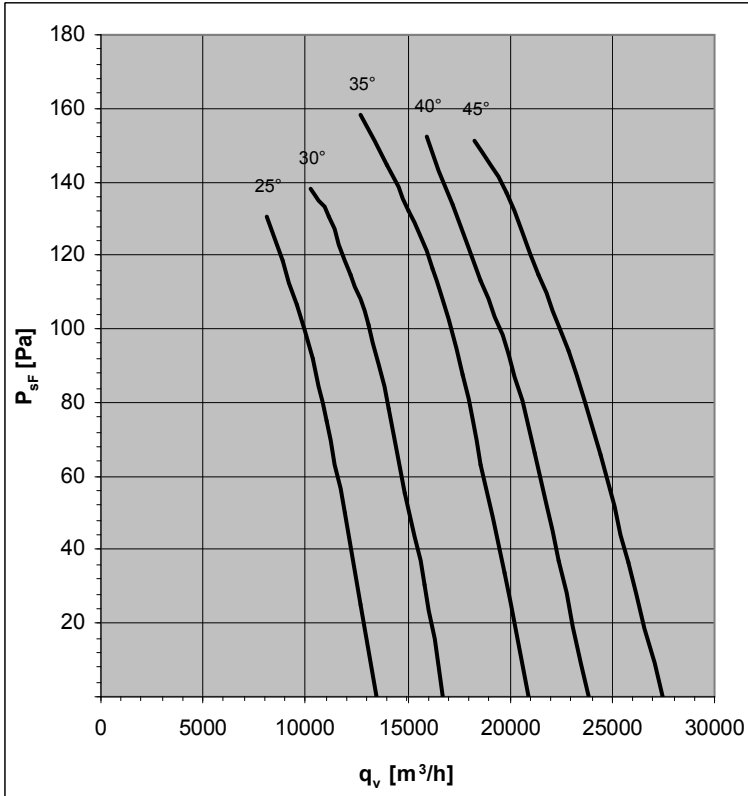

Design K

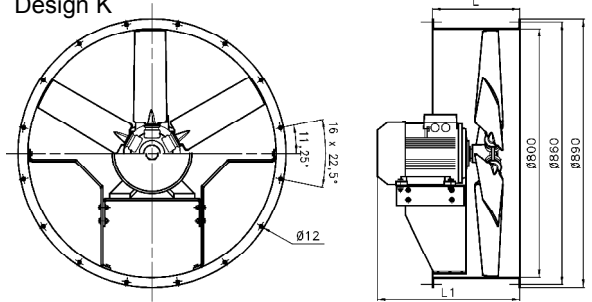

Design F

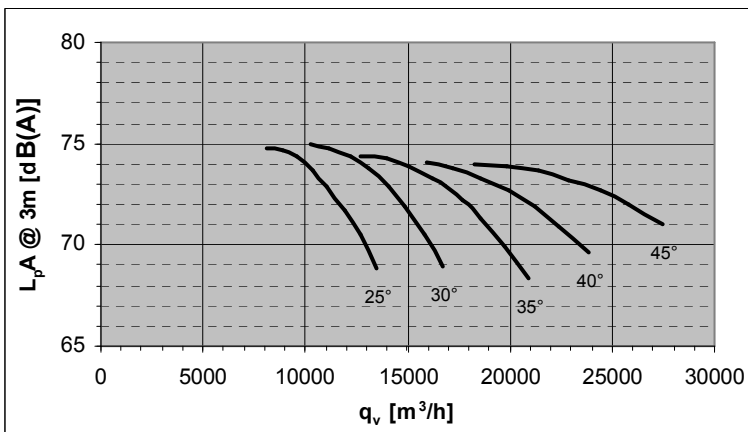
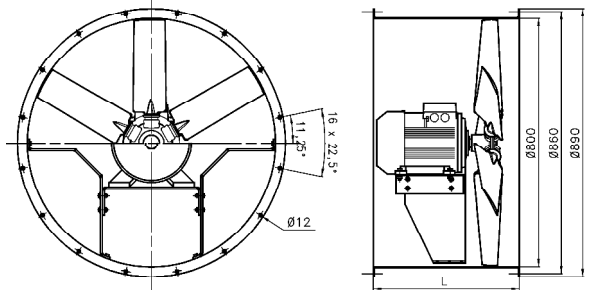

Pitch Angle	Relative spectrum							
	63	125	250	500	1000	2000	4000	8000
25°	-43	-34	-15	-7	-4	-6	-11	-21
30°	-42	-33	-15	-7	-4	-6	-10	-20
35°	-41	-32	-15	-7	-4	-5	-10	-19
40°	-40	-31	-16	-8	-4	-5	-9	-18
45°	-40	-31	-16	-8	-4	-5	-9	-17

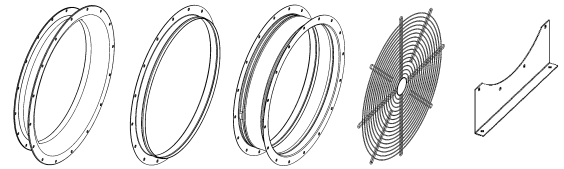

Accessories : see pages 100-102

Design	Pitch Angle	Type (G finish)	Part N°	Type (H finish)	Part N°	L1(mm)	L(mm)	Weight (kg)
K	25°	FV80V-6DK.B7.25.G	150553	FV80V-6DK.B7.25.H	150554	365	280	45
	30°	FV80V-6DK.D7.30.G	150601	FV80V-6DK.D7.30.H	150602	413	280	51
	35°	FV80V-6DK.E7.35.G	150605	FV80V-6DK.E7.35.H	150606	485	280	54
	40°	FV80V-6DK.E7.40.G	150565	FV80V-6DK.E7.40.H	150566	485	280	54
	45°	FV80V-6DK.F7.45.G	150569	FV80V-6DK.F7.45.H	150570	482	400	72
F	25°	FV80V-6DF.B7.25.G	150555	FV80V-6DF.B7.25.H	150556	---	500	57
	30°	FV80V-6DF.D7.30.G	150603	FV80V-6DF.D7.30.H	150604	---	500	63
	35°	FV80V-6DF.E7.35.G	150607	FV80V-6DF.E7.35.H	150608	---	500	66
	40°	FV80V-6DF.E7.40.G	150567	FV80V-6DF.E7.40.H	150568	---	500	66
	45°	FV80V-6DF.F7.45.G	150571	FV80V-6DF.F7.45.H	150572	---	500	78

FV80V-8D

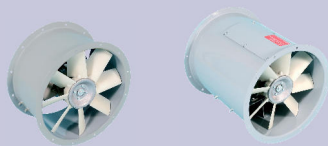

50Hz Motor	U	I	P ₂	n	
	V	A	kW	min ⁻¹	
25°	80 M	400	1,02	0,25	685
30°	90 S	400	1,14	0,37	675
35°	90 L	400	1,58	0,55	675
40°	100 L	400	2,45	0,75	695
45°	100 L	400	2,45	0,75	695

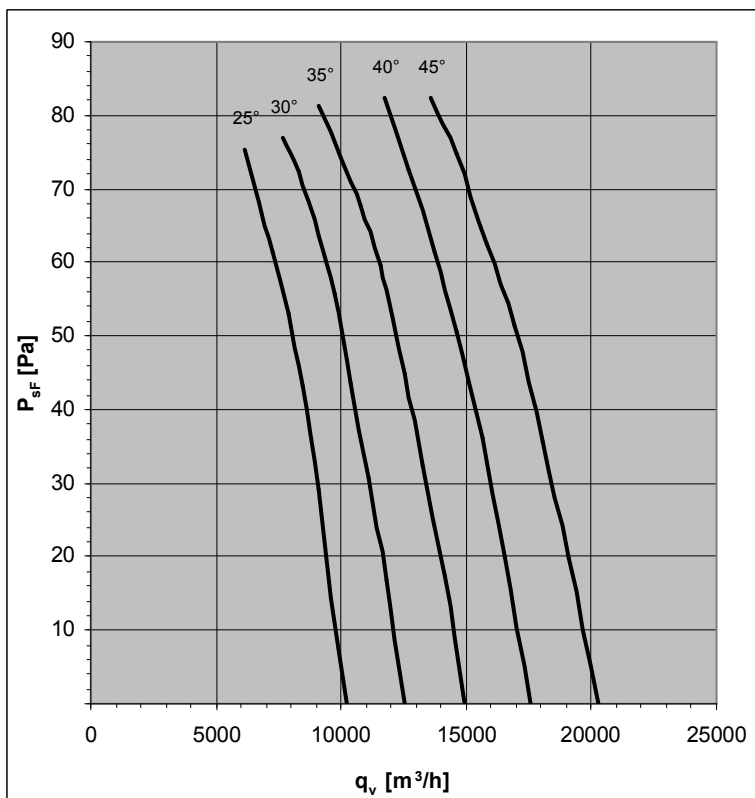

Design K

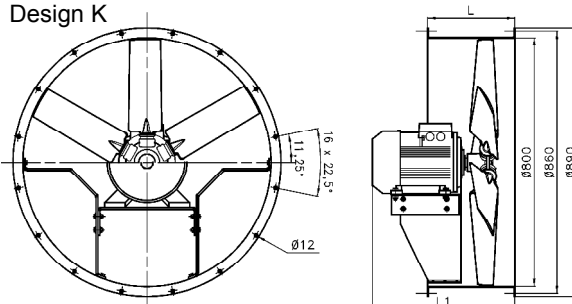

Design F

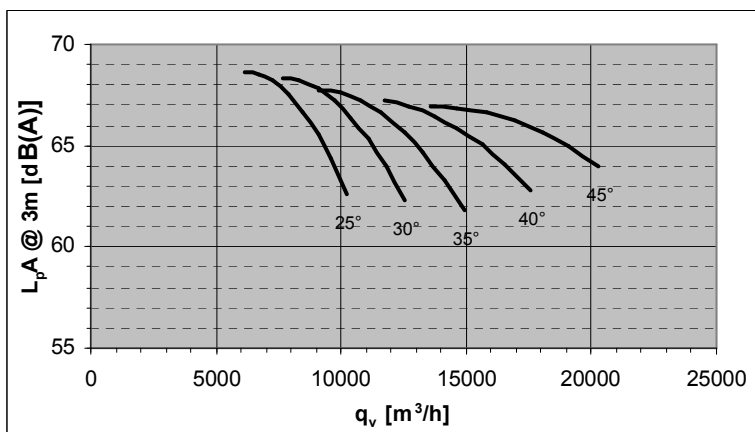
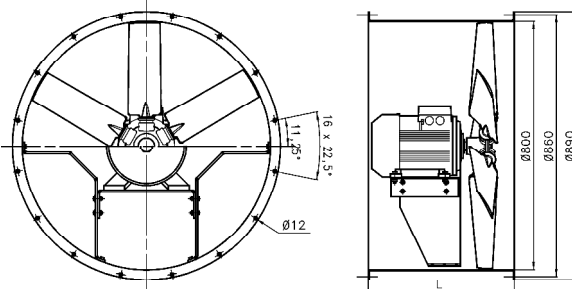

Pitch Angle	Relative spectrum							
	63	125	250	500	1000	2000	4000	8000
25°	-40	-32	-14	-7	-4	-5	-10	-19
30°	-39	-31	-14	-7	-4	-5	-10	-18
35°	-38	-29	-14	-7	-4	-5	-9	-17
40°	-37	-29	-14	-7	-4	-5	-8	-16
45°	-37	-28	-15	-7	-4	-5	-8	-16

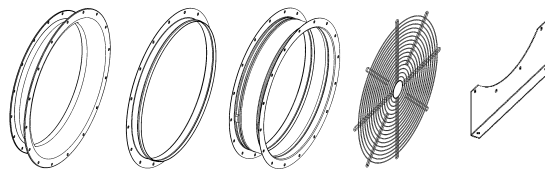

Accessories : see pages 100-102

Design	Pitch Angle	Type (G finish)	Part N°	Type (H finish)	Part N°	L1(mm)	L(mm)	Weight (kg)
K	25°	FV80V-8DK.B7.25.G	150573	FV80V-8DK.B7.25.H	150574	365	280	45
	30°	FV80V-8DK.C7.30.G	150577	FV80V-8DK.C7.30.H	150578	413	280	46
	35°	FV80V-8DK.D7.35.G	150581	FV80V-8DK.D7.35.H	150582	413	280	48
	40°	FV80V-8DK.E7.40.G	150609	FV80V-8DK.E7.40.H	150610	485	280	52
	45°	FV80V-8DK.E7.45.G	150589	FV80V-8DK.E7.45.H	150590	485	280	52
F	25°	FV80V-8DF.B7.25.G	150575	FV80V-8DF.B7.25.H	150576	---	500	57
	30°	FV80V-8DF.C7.30.G	150579	FV80V-8DF.C7.30.H	150580	---	500	58
	35°	FV80V-8DF.D7.35.G	150583	FV80V-8DF.D7.35.H	150584	---	500	60
	40°	FV80V-8DF.E7.40.G	150611	FV80V-8DF.E7.40.H	150612	---	500	64
	45°	FV80V-8DF.E7.45.G	150591	FV80V-8DF.E7.45.H	150592	---	500	64

FV90V-4D

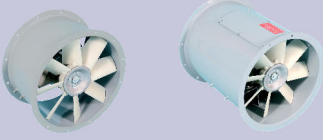

50Hz Motor	U	I	P ₂	n	
	V	A	kW	min ⁻¹	
25°	100 L	400	6,2	3	1425
30°	132 S	400	11,2	5,5	1450
35°	132 M	400	15	7,5	1450
40°	160 M	400	22	11	1460
45°	160 M	400	22	11	1460

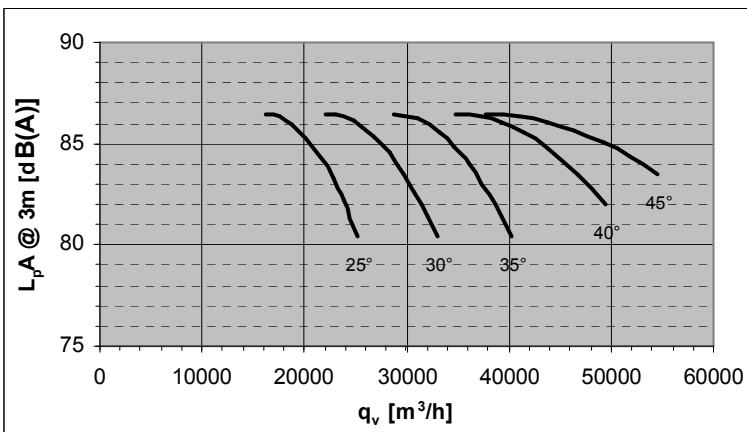
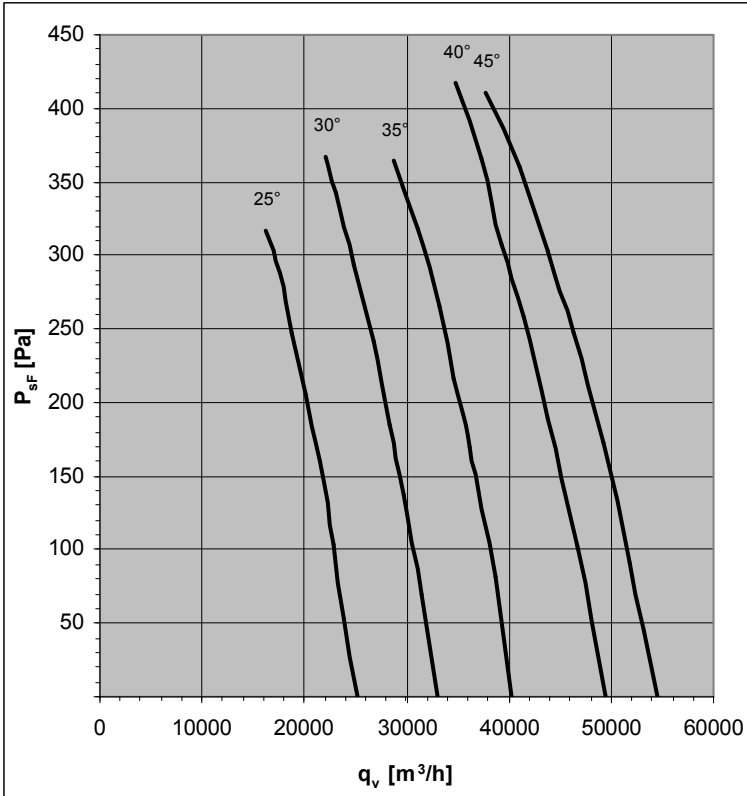

Design K

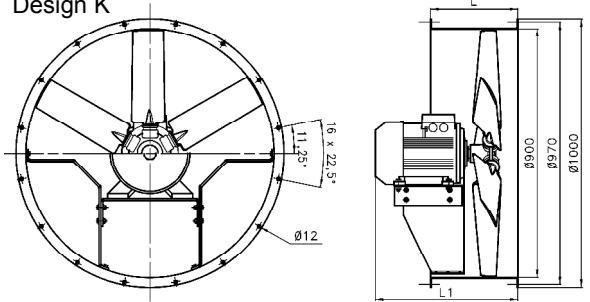

Design F

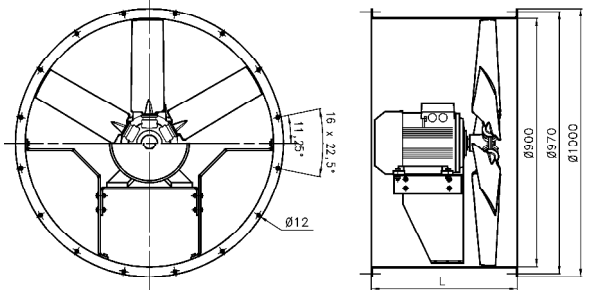

Pitch Angle	Relative spectrum							
	63	125	250	500	1000	2000	4000	8000
25°	-49	-39	-17	-8	-5	-7	-13	-24
30°	-48	-38	-17	-8	-5	-6	-12	-22
35°	-47	-36	-17	-8	-5	-6	-11	-21
40°	-46	-36	-18	-9	-5	-6	-10	-20
45°	-45	-35	-18	-9	-5	-6	-10	-19

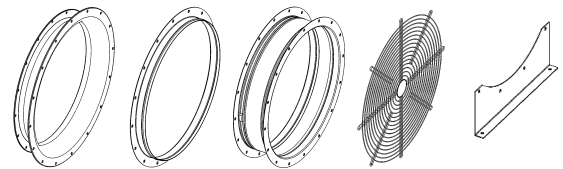

Accessories : see pages 100-102

Design	Pitch Angle	Type (G finish)	Part N°	Type (H finish)	Part N°	L1(mm)	L(mm)	Weight (kg)
K	25°	FV90V-4DK.E7.25.G	150613	FV90V-4DK.E7.25.H	150614	485	280	63
	30°	FV90V-4DK.G7.30.G	150673	FV90V-4DK.G7.30.H	150674	560	400	92
	35°	FV90V-4DK.H7.35.G	150677	FV90V-4DK.H7.35.H	150678	560	400	98
	40°	FV90V-4DK.I7.40.G	150681	FV90V-4DK.I7.40.H	150682	695	400	121
	45°	FV90V-4DK.I7.45.G	150629	FV90V-4DK.I7.45.H	150630	695	400	121
F	25°	FV90V-4DF.E7.25.G	150615	FV90V-4DF.E7.25.H	150616	---	500	77
	30°	FV90V-4DF.G7.30.G	150675	FV90V-4DF.G7.30.H	150676	---	700	110
	35°	FV90V-4DF.H7.35.G	150679	FV90V-4DF.H7.35.H	150680	---	700	116
	40°	FV90V-4DF.I7.40.G	150683	FV90V-4DF.I7.40.H	150684	---	700	140
	45°	FV90V-4DF.I7.45.G	150631	FV90V-4DF.I7.45.H	150632	---	700	140

FV90V-6D

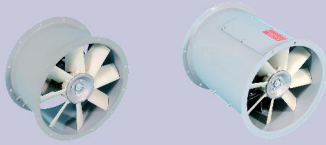

50Hz Motor	U	I	P ₂	n	
	V	A	kW	min ⁻¹	
25°	90 S	400	2,05	0,75	915
30°	90 L	400	2,85	1,1	915
35°	112 M	400	5,3	2,2	930
40°	112 M	400	5,3	2,2	930
45°	132 S	400	7,2	3	955

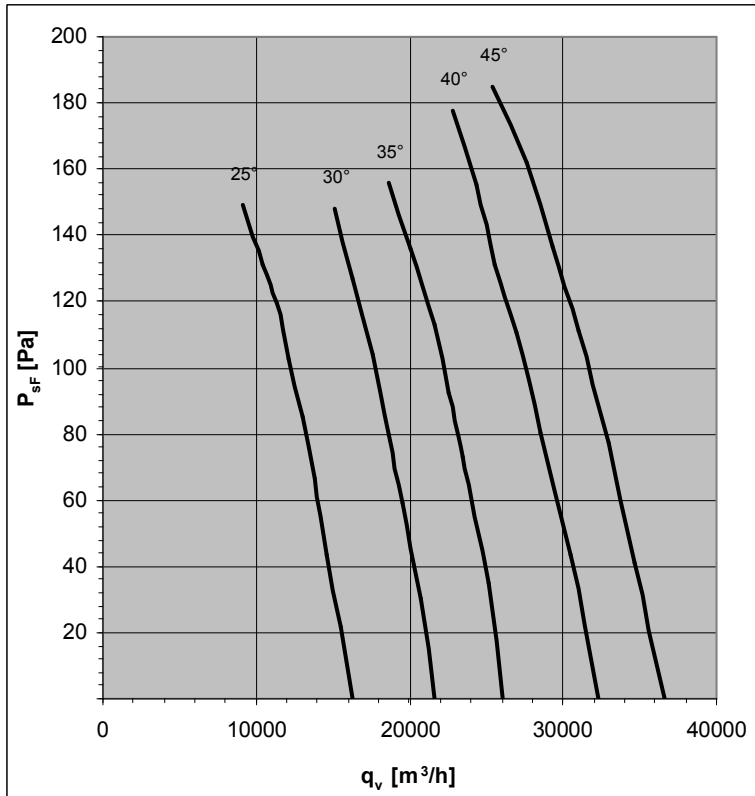

Design K

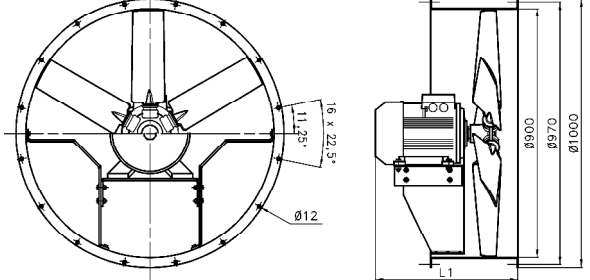

Design F

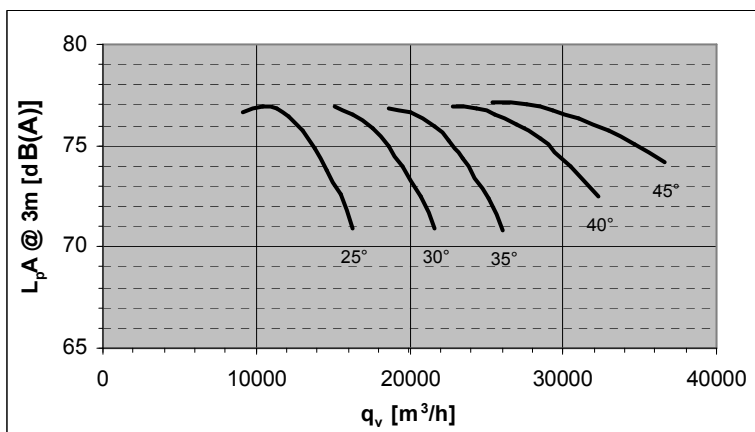
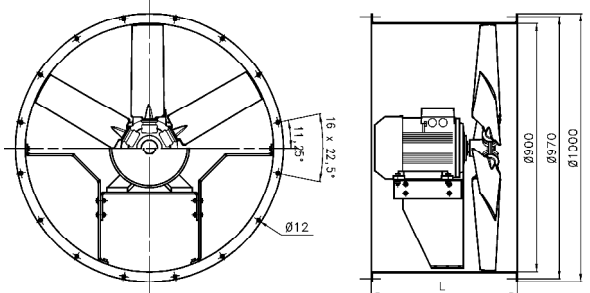

Pitch Angle	Relative spectrum							
	63	125	250	500	1000	2000	4000	8000
25°	-44	-35	-15	-8	-4	-6	-11	-21
30°	-43	-34	-15	-8	-4	-6	-11	-20
35°	-42	-33	-16	-8	-4	-6	-10	-19
40°	-42	-32	-16	-8	-4	-6	-9	-18
45°	-41	-32	-16	-8	-4	-5	-9	-18

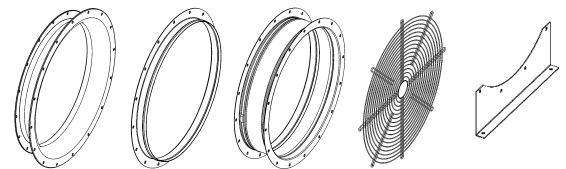

Accessories : see pages 100-102

Design	Pitch Angle	Type (G finish)	Part N°	Type (H finish)	Part N°	L1(mm)	L(mm)	Weight (kg)
K	25°	FV90V-6DK.C7.25.G	150633	FV90V-6DK.C7.25.H	150634	413	280	54
	30°	FV90V-6DK.D7.30.G	150637	FV90V-6DK.D7.30.H	150638	413	280	57
	35°	FV90V-6DK.F7.35.G	150685	FV90V-6DK.F7.35.H	150686	482	400	79
	40°	FV90V-6DK.F7.40.G	150645	FV90V-6DK.F7.40.H	150646	482	400	79
	45°	FV90V-6DK.G7.45.G	150649	FV90V-6DK.G7.45.H	150650	560	400	88
F	25°	FV90V-6DF.C7.25.G	150635	FV90V-6DF.C7.25.H	150636	---	500	68
	30°	FV90V-6DF.D7.30.G	150639	FV90V-6DF.D7.30.H	150640	---	500	71
	35°	FV90V-6DF.F7.35.G	150687	FV90V-6DF.F7.35.H	150688	---	500	85
	40°	FV90V-6DF.F7.40.G	150647	FV90V-6DF.F7.40.H	150648	---	500	85
	45°	FV90V-6DF.G7.45.G	150651	FV90V-6DF.G7.45.H	150652	---	700	106

FV90V-8D



50Hz Motor	U	I	P ₂	n	
	V	A	kW	min ⁻¹	
25°	90 S	400	1,14	0,37	675
30°	90 L	400	1,58	0,55	675
35°	100 L	400	2,45	0,75	695
40°	100 L	400	3,5	1,1	695
45°	100 L	400	3,5	1,1	695

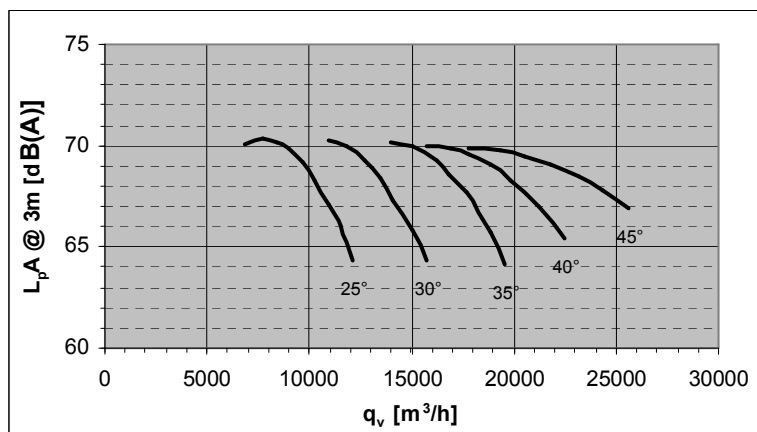
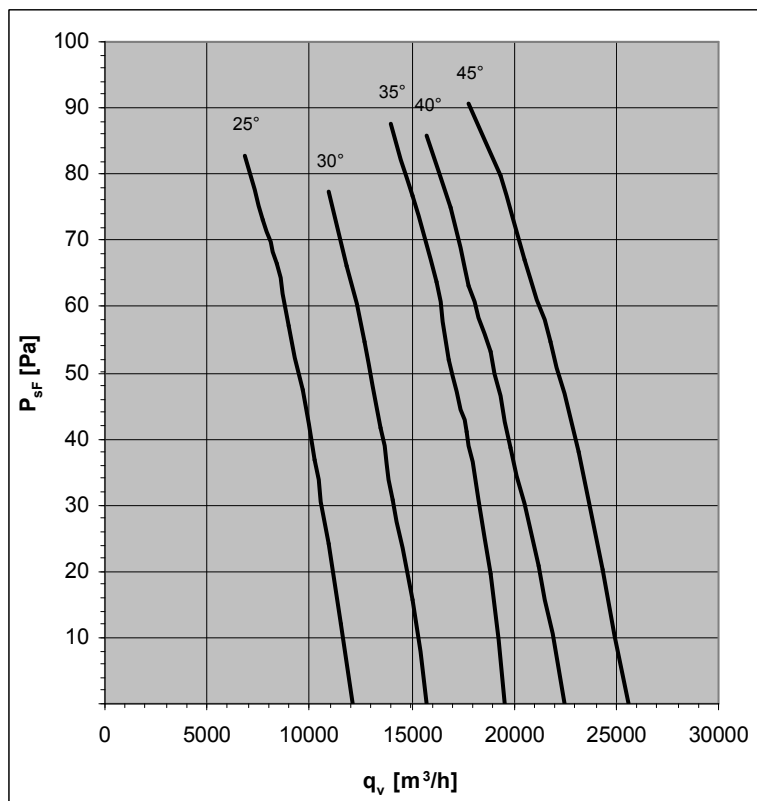

Design K

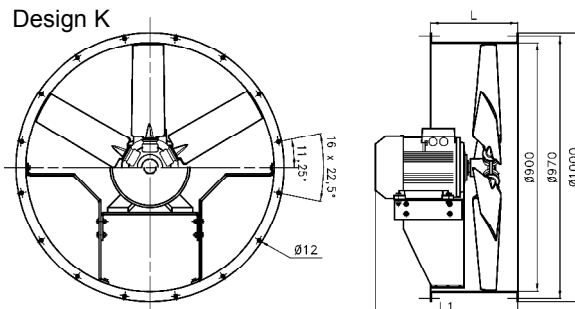

Design F

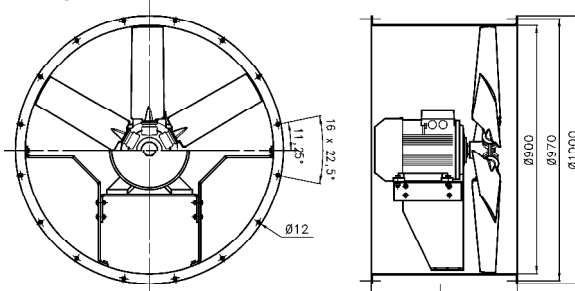

Pitch Angle	Relative spectrum							
	63	125	250	500	1000	2000	4000	8000
25°	-41	-32	-14	-7	-4	-6	-10	-20
30°	-40	-31	-14	-7	-4	-5	-10	-19
35°	-39	-30	-14	-7	-4	-5	-9	-18
40°	-38	-30	-15	-7	-4	-5	-9	-17
45°	-38	-29	-15	-7	-4	-5	-8	-16

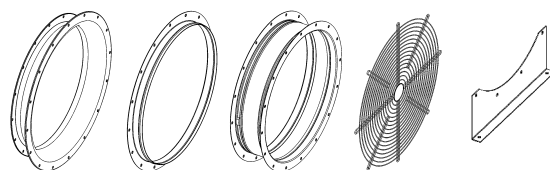

Accessories : see pages 100-102

Design	Pitch Angle	Type (G finish)	Part N°	Type (H finish)	Part N°	L1(mm)	L(mm)	Weight (kg)
K	25°	FV90V-8DK.C7.25.G	150653	FV90V-8DK.C7.25.H	150654	413	280	52
	30°	FV90V-8DK.D7.30.G	150657	FV90V-8DK.D7.30.H	150658	413	280	54
	35°	FV90V-8DK.E7.35.G	150661	FV90V-8DK.E7.35.H	150662	485	280	58
	40°	FV90V-8DK.E7.40.G	150689	FV90V-8DK.E7.40.H	150690	485	280	63
	45°	FV90V-8DK.E7.45.G	150669	FV90V-8DK.E7.45.H	150670	485	280	63
F	25°	FV90V-8DF.C7.25.G	150655	FV90V-8DF.C7.25.H	150656	---	500	66
	30°	FV90V-8DF.D7.30.G	150659	FV90V-8DF.D7.30.H	150660	---	500	68
	35°	FV90V-8DF.E7.35.G	150663	FV90V-8DF.E7.35.H	150664	---	500	72
	40°	FV90V-8DF.E7.40.G	150691	FV90V-8DF.E7.40.H	150692	---	500	77
	45°	FV90V-8DF.E7.45.G	150671	FV90V-8DF.E7.45.H	150672	---	500	77

FV10V-4D

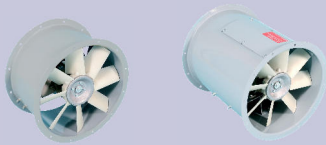

50Hz Motor	U V	I A	P ₂ kW	n min ⁻¹	
30°	160 M	400	22	11	1460
35°	160 L	400	29,5	15	1460
40°	180 M	400	35	18,5	1465
45°	180 L	400	41,5	22	1465
50°	200 L	400	56	30	1465

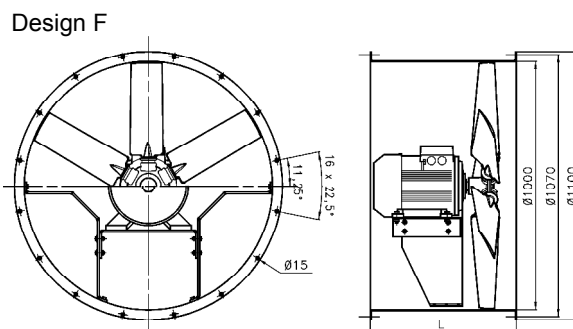
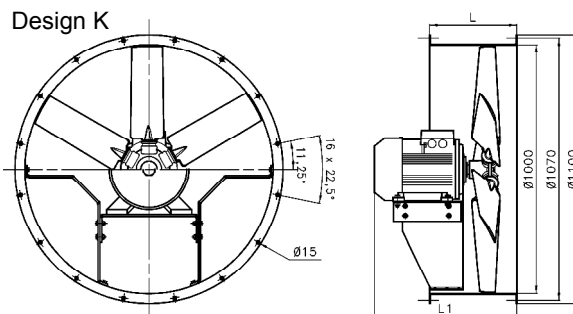
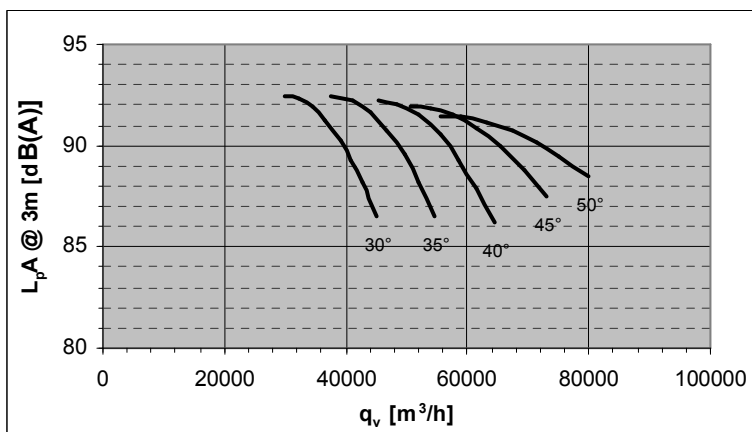
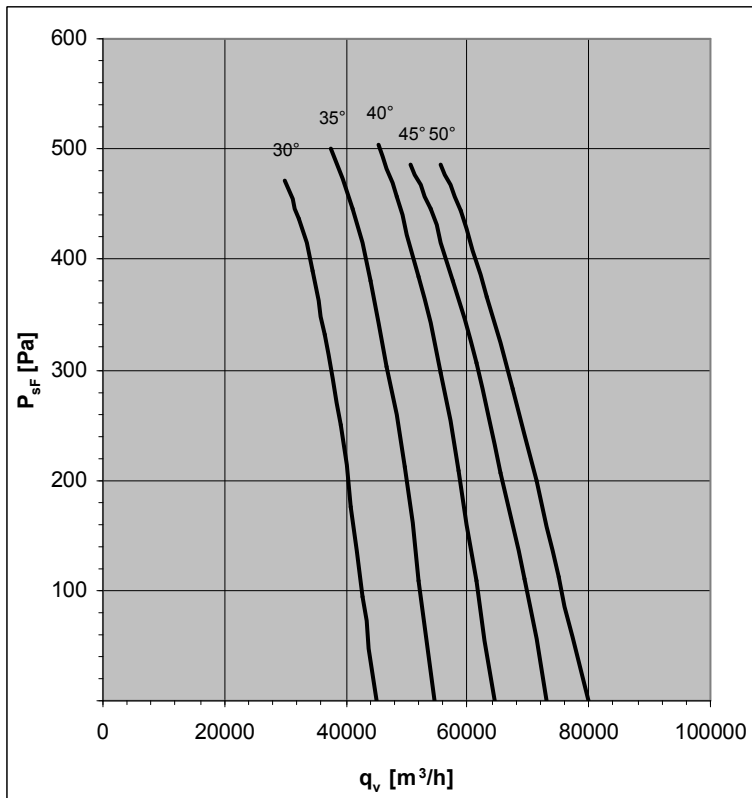

Pitch Angle	Relative spectrum							
	63	125	250	500	1000	2000	4000	8000
30°	-52	-41	-18	-9	-5	-7	-13	-25
35°	-51	-40	-18	-9	-5	-7	-12	-24
40°	-49	-39	-18	-9	-5	-7	-12	-22
45°	-49	-38	-19	-9	-5	-6	-11	-21
50°	-48	-37	-19	-9	-5	-6	-10	-20

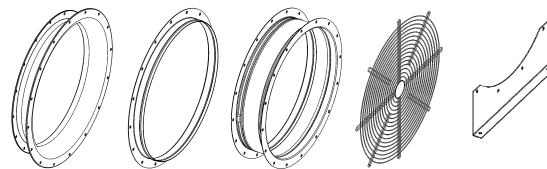

Accessories : see pages 100-102

Design	Pitch Angle	Type (G finish)	Part N°	Type (H finish)	Part N°	L1(mm)	L(mm)	Weight (kg)
K	30°	FV10V-4DK.I7.30.G	150753	FV10V-4DK.I7.30.H	150754	695	400	133
	35°	FV10V-4DK.K7.35.G	150757	FV10V-4DK.K7.35.H	150758	695	400	144
	40°	FV10V-4DK.L7.40.G	150761	FV10V-4DK.L7.40.H	150762	756	450	237
	45°	FV10V-4DK.M7.45.G	150765	FV10V-4DK.M7.45.H	150766	756	450	252
	50°	FV10V-4DK.N7.50.G	150709	FV10V-4DK.N7.50.H	150710	850	450	302
F	30°	FV10V-4DF.I7.30.G	150755	FV10V-4DF.I7.30.H	150756	---	700	155
	35°	FV10V-4DF.K7.35.G	150759	FV10V-4DF.K7.35.H	150760	---	700	166
	40°	FV10V-4DF.L7.40.G	150763	FV10V-4DF.L7.40.H	150764	---	860	268
	45°	FV10V-4DF.M7.45.G	150767	FV10V-4DF.M7.45.H	150768	---	860	283
	50°	FV10V-4DF.N7.50.G	150711	FV10V-4DF.N7.50.H	150712	---	860	333

Increased Temperature Range : -30°C / +60°C

FV10V-6D

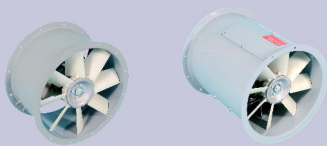

50Hz Motor	U	I	P ₂	n	
	V	A	kW	min ⁻¹	
30°	112 M	400	5,3	2,2	930
35°	132 M	400	9,2	4	950
40°	132 M	400	12,4	5,5	950
45°	160 M	400	17,2	7,5	970
50°	160 M	400	17,2	7,5	970

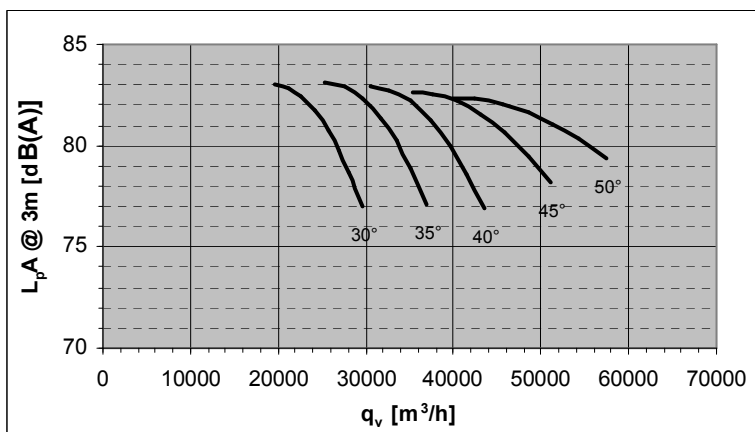
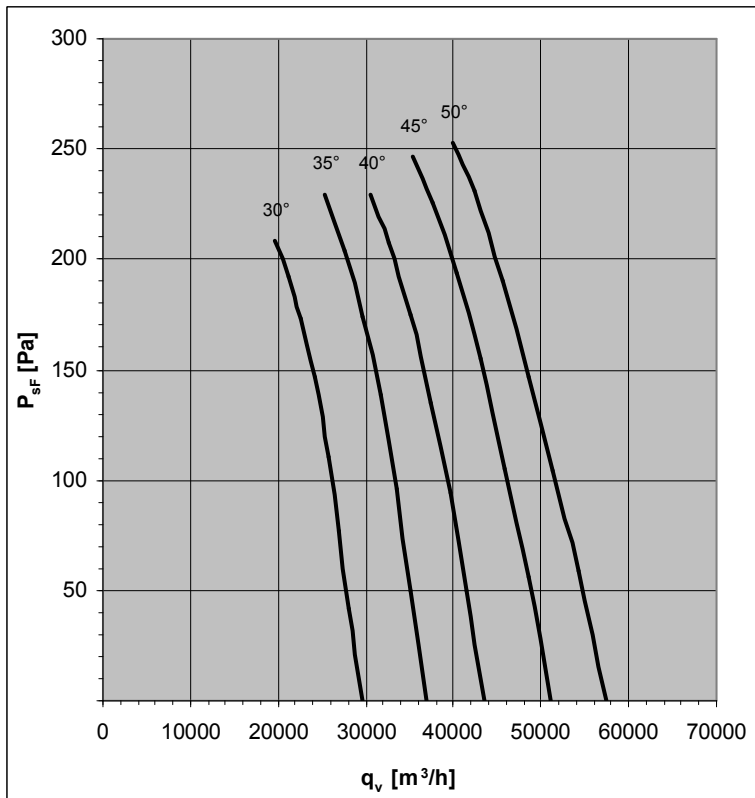

Design K

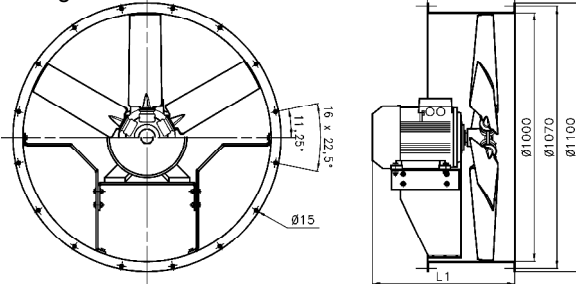

Design F

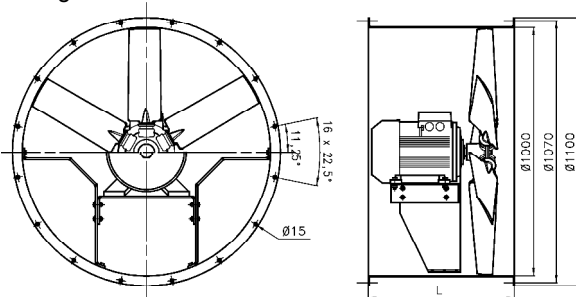

Pitch Angle	Relative spectrum							
	63	125	250	500	1000	2000	4000	8000
30°	-47	-37	-16	-8	-4	-6	-12	-23
35°	-46	-36	-17	-8	-4	-6	-11	-22
40°	-45	-35	-17	-8	-4	-6	-11	-20
45°	-44	-34	-17	-8	-4	-6	-10	-19
50°	-44	-34	-17	-9	-4	-6	-9	-19

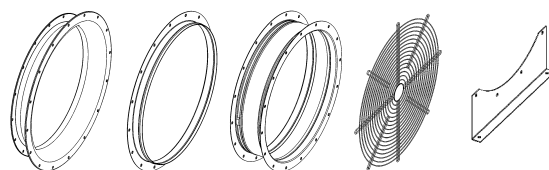

Accessories : see pages 100-102

Design	Pitch Angle	Type (G finish)	Part N°	Type (H finish)	Part N°	L1(mm)	L(mm)	Weight (kg)
K	30°	FV10V-6DK.F7.30.G	150713	FV10V-6DK.F7.30.H	150714	482	400	88
	35°	FV10V-6DK.H7.35.G	150769	FV10V-6DK.H7.35.H	150770	560	400	102
	40°	FV10V-6DK.H7.40.G	150773	FV10V-6DK.H7.40.H	150774	560	400	111
	45°	FV10V-6DK.I7.45.G	150777	FV10V-6DK.I7.45.H	150778	695	400	143
	50°	FV10V-6DK.I7.50.G	150729	FV10V-6DK.I7.50.H	150730	695	400	143
F	30°	FV10V-6DF.F7.30.G	150715	FV10V-6DF.F7.30.H	150716	---	700	111
	35°	FV10V-6DF.H7.35.G	150771	FV10V-6DF.H7.35.H	150772	---	700	125
	40°	FV10V-6DF.H7.40.G	150775	FV10V-6DF.H7.40.H	150776	---	700	134
	45°	FV10V-6DF.I7.45.G	150779	FV10V-6DF.I7.45.H	150780	---	700	165
	50°	FV10V-6DF.I7.50.G	150731	FV10V-6DF.I7.50.H	150732	---	700	165

FV10V-8D



50Hz Motor	U	I	P ₂	n
	V	A	kW	min ⁻¹
30°	112 M	4,00	1,5	675
35°	112 M	4,00	1,5	675
40°	132 S	4,00	2,2	720
45°	132 M	4,00	3,0	715
50°	132 M	4,00	3,0	715

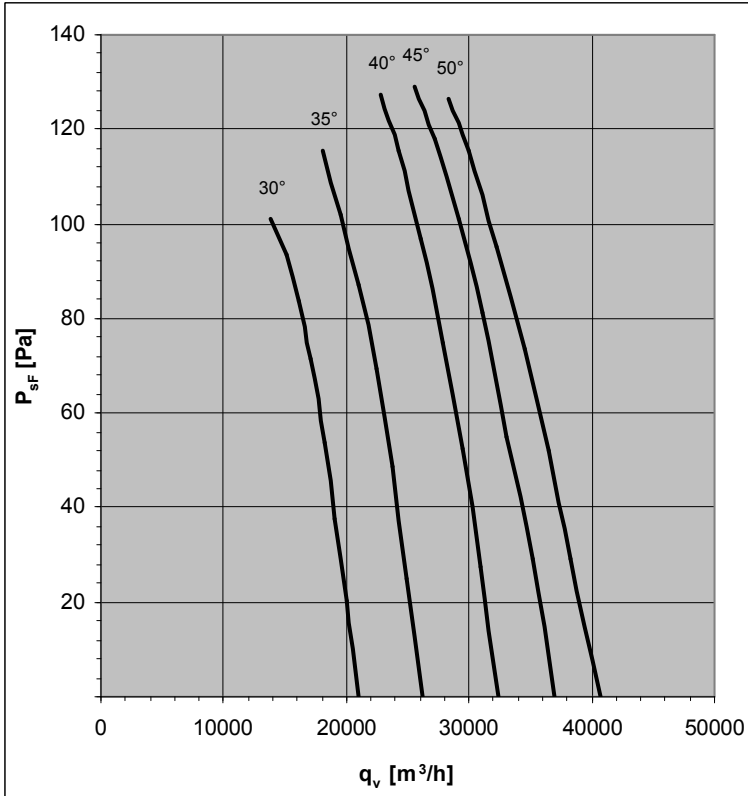

Design K

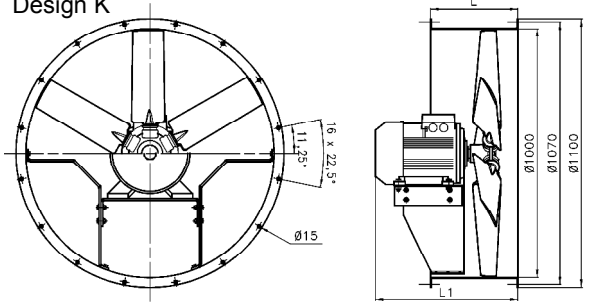

Design F

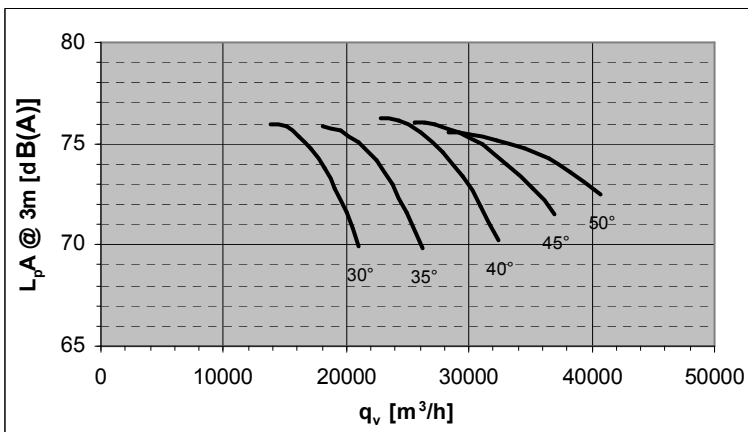
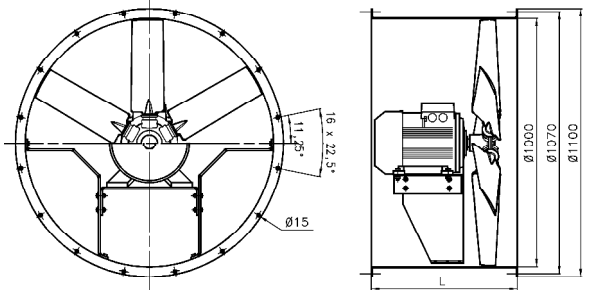

Pitch Angle	Relative spectrum							
	63	125	250	500	1000	2000	4000	8000
30°	-44	-35	-15	-7	-4	-6	-11	-21
35°	-43	-34	-15	-7	-4	-6	-10	-20
40°	-42	-33	-15	-8	-4	-6	-10	-19
45°	-41	-32	-16	-8	-4	-5	-9	-18
50°	-41	-31	-16	-8	-4	-5	-9	-17

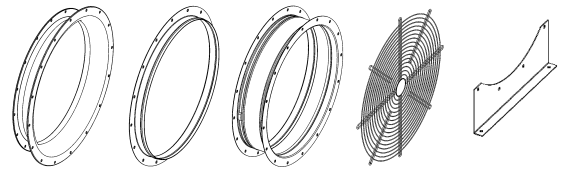

Accessories : see pages 100-102

Design	Pitch Angle	Type (G finish)	Part N°	Type (H finish)	Part N°	L1(mm)	L(mm)	Weight (kg)
K	30°	FV10V-8DK.F7.30.G	150733	FV10V-8DK.F7.30.H	150734	482	400	88
	35°	FV10V-8DK.F7.35.G	150737	FV10V-8DK.F7.35.H	150738	482	400	88
	40°	FV10V-8DK.G7.40.G	150741	FV10V-8DK.G7.40.H	150742	560	400	100
	45°	FV10V-8DK.H7.45.G	150781	FV10V-8DK.H7.45.H	150782	560	400	107
	50°	FV10V-8DK.H7.50.G	150749	FV10V-8DK.H7.50.H	150750	560	400	107
F	30°	FV10V-8DF.F7.30.G	150735	FV10V-8DF.F7.30.H	150736	---	700	111
	35°	FV10V-8DF.F7.35.G	150739	FV10V-8DF.F7.35.H	150740	---	700	111
	40°	FV10V-8DF.G7.40.G	150743	FV10V-8DF.G7.40.H	150744	---	700	123
	45°	FV10V-8DF.H7.45.G	150783	FV10V-8DF.H7.45.H	150784	---	700	130
	50°	FV10V-8DF.H7.50.G	150751	FV10V-8DF.H7.50.H	150752	---	700	130

FV12V-4D

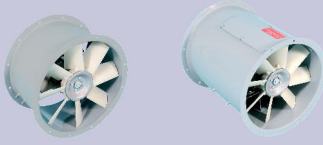

50Hz Motor	U	I	P ₂	n	
	V	A	kW	min ⁻¹	
22°	180 L	400	41,5	22	1465
24°	200 L	400	56	30	1465
29°	225 S	400	68	37	1475
32°	225 M	400	81	45	1475
-	-	400	-	-	-

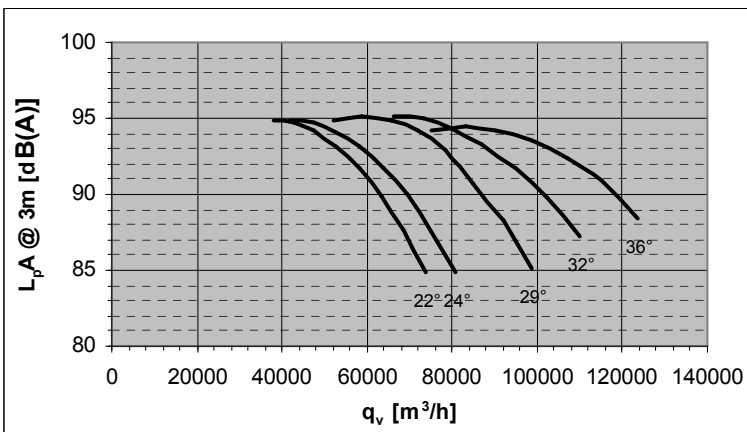
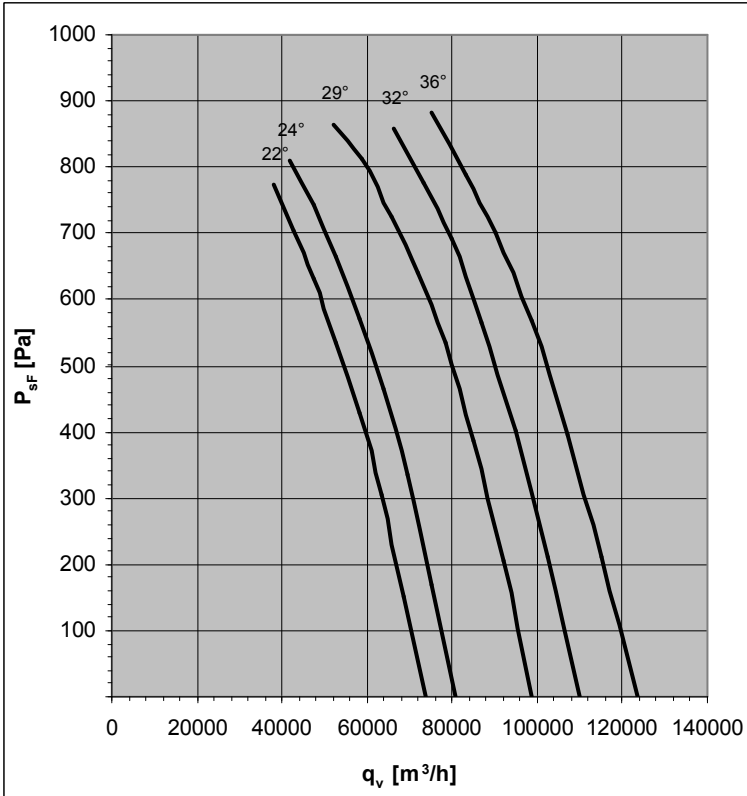

Design K

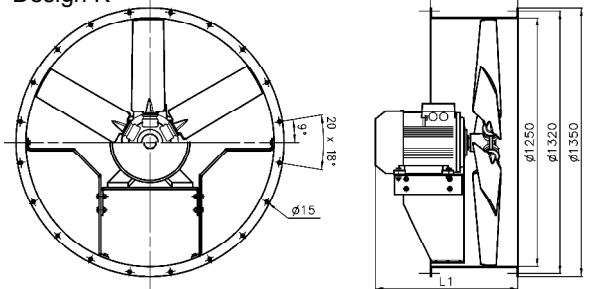

Design F

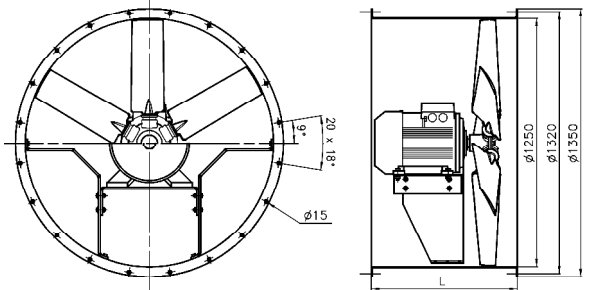

Pitch Angle	Relative spectrum							
	63	125	250	500	1000	2000	4000	8000
22°	-51	-40	-18	-9	-5	-7	-13	-25
24°	-50	-39	-18	-9	-5	-7	-12	-23
29°	-49	-38	-18	-9	-5	-7	-12	-22
32°	-48	-38	-19	-9	-5	-6	-11	-21
36°	-48	-37	-19	-9	-5	-6	-10	-20

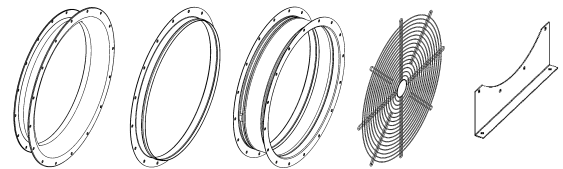

Accessories : see pages 100-102

Design	Pitch Angle	Type (G finish)	Part N°	Type (H finish)	Part N°	L1(mm)	L(mm)	Weight (kg)
K	22°	FV12V-4DK.M7.22.G	150845	FV12V-4DK.M7.22.H	150846	798	500	281
	24°	FV12V-4DK.N7.24.G	150849	FV12V-4DK.N7.24.H	150850	850	500	331
	29°	FV12V-4DK.P7.29.G	150853	FV12V-4DK.P7.29.H	150854	920	500	391
	32°	FV12V-4DK.R7.32.G	150857	FV12V-4DK.R7.32.H	150858	920	500	426
	-	-	-	-	-	---	---	---
F	22°	FV12V-4DF.M7.22.G	150847	FV12V-4DF.M7.22.H	150848	---	930	321
	24°	FV12V-4DF.N7.24.G	150851	FV12V-4DF.N7.24.H	150852	---	930	371
	29°	FV12V-4DF.P7.29.G	150855	FV12V-4DF.P7.29.H	150856	---	930	431
	32°	FV12V-4DF.R7.32.G	150859	FV12V-4DF.R7.32.H	150860	---	930	466
	-	-	-	-	-	---	---	---

FV12V-6D

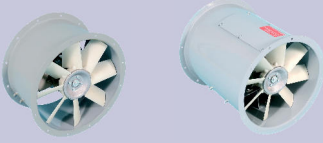

50Hz Motor	U V	I A	P ₂ kW	n min ⁻¹	
23°	160 M	400	17,2	7,5	970
27°	160 L	400	23,5	11	965
34°	180 L	400	29,5	15	965
39°	200 L	400	36,5	18,5	975
43°	200 L	400	43,5	22	975

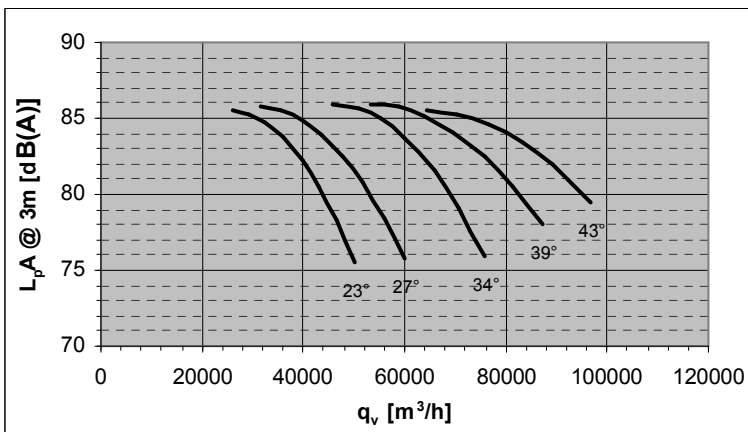
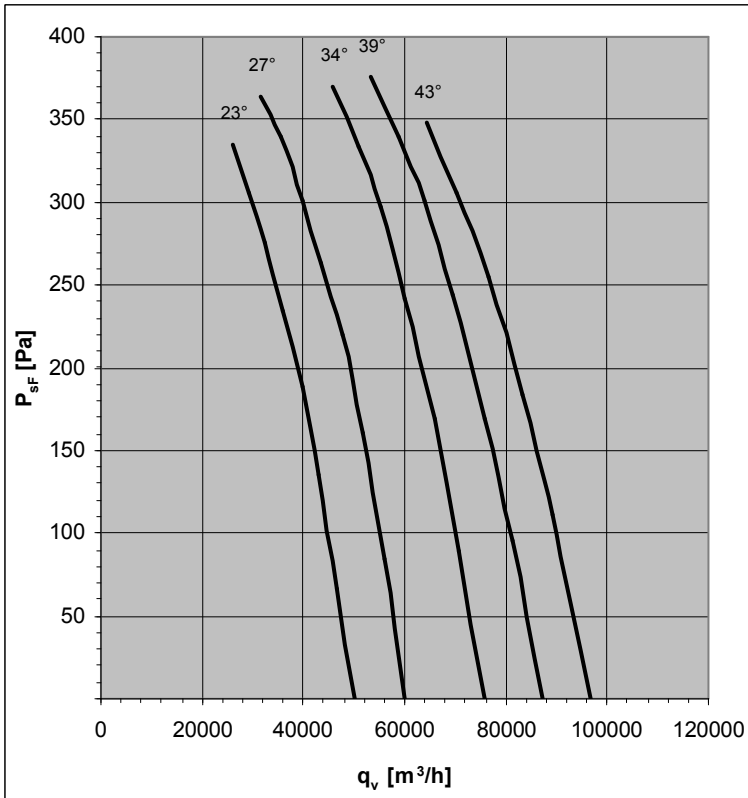

Design K

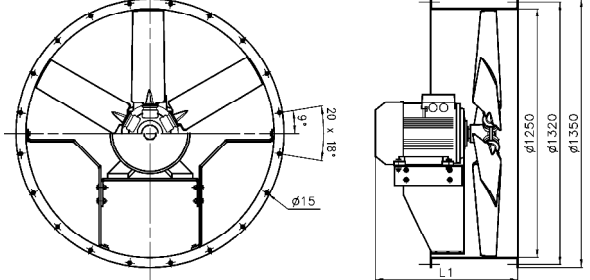

Design F

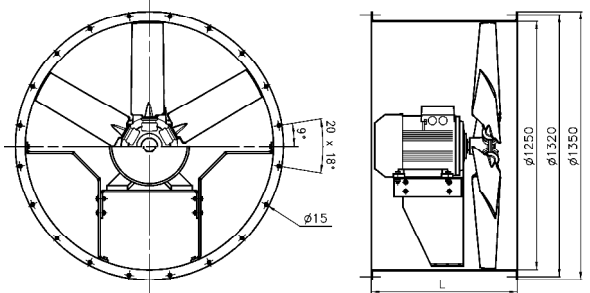

Pitch Angle	Relative spectrum							
	63	125	250	500	1000	2000	4000	8000
23°	-47	-37	-16	-8	-4	-6	-12	-22
27°	-45	-36	-16	-8	-4	-6	-11	-21
34°	-44	-35	-17	-8	-4	-6	-10	-20
39°	-44	-34	-17	-8	-4	-6	-10	-19
43°	-44	-34	-17	-9	-4	-6	-9	-19

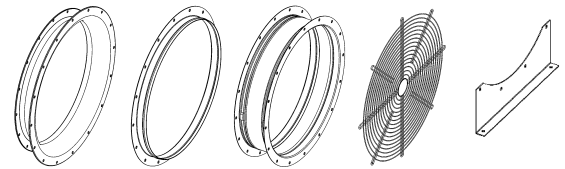

Accessories : see pages 100-102

Design	Pitch Angle	Type (G finish)	Part N°	Type (H finish)	Part N°	L1(mm)	L(mm)	Weight (kg)
K	23°	FV12V-6DK.I7.23.G	150861	FV12V-6DK.I7.23.H	150862	756	500	172
	27°	FV12V-6DK.K7.27.G	150865	FV12V-6DK.K7.27.H	150866	756	500	192
	34°	FV12V-6DK.M7.34.G	150869	FV12V-6DK.M7.34.H	150870	798	500	276
	39°	FV12V-6DK.N7.39.G	150873	FV12V-6DK.N7.39.H	150874	850	500	321
	43°	FV12V-6DK.N7.43.G	150877	FV12V-6DK.N7.43.H	150878	850	500	331
F	23°	FV12V-6DF.I7.23.G	150863	FV12V-6DF.I7.23.H	150864	---	760	195
	27°	FV12V-6DF.K7.27.G	150867	FV12V-6DF.K7.27.H	150868	---	760	215
	34°	FV12V-6DF.M7.34.G	150871	FV12V-6DF.M7.34.H	150872	---	930	316
	39°	FV12V-6DF.N7.39.G	150875	FV12V-6DF.N7.39.H	150876	---	930	361
	43°	FV12V-6DF.N7.43.G	150879	FV12V-6DF.N7.43.H	150880	---	930	371



Increased Temperature Range : -30°C / +60°C

FV12V-8D

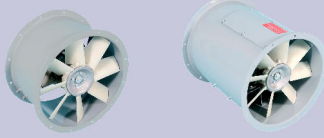

50Hz Motor	U	I	P ₂	n	
	V	A	kW	min ⁻¹	
28°	160 M	400	10,4	4	720
31°	160 M	400	13,6	5,5	720
38°	160 L	400	18,6	7,5	715
43°	180 L	400	25	11	725
50°	200 L	400	32,5	15	725

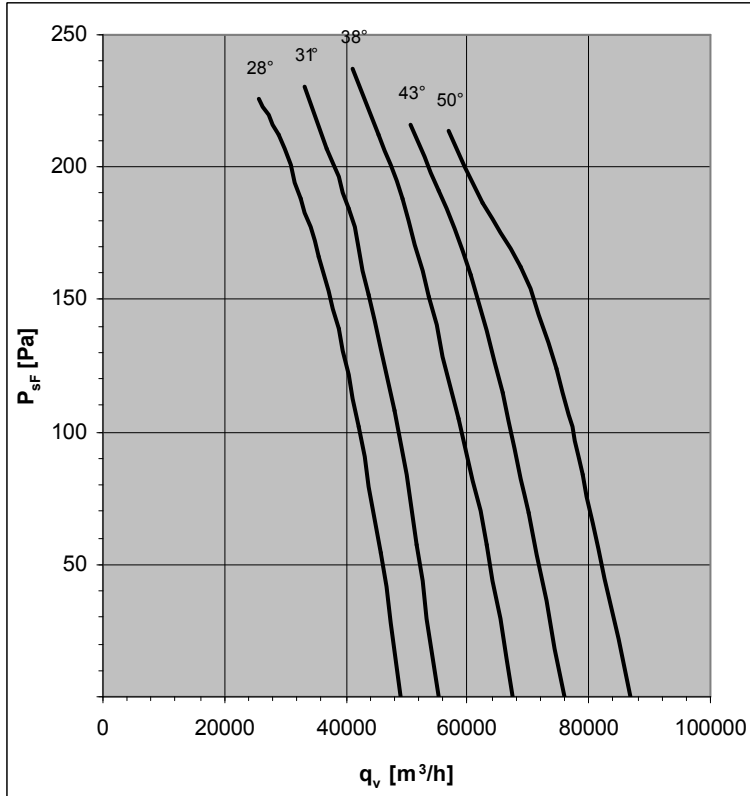

Design K

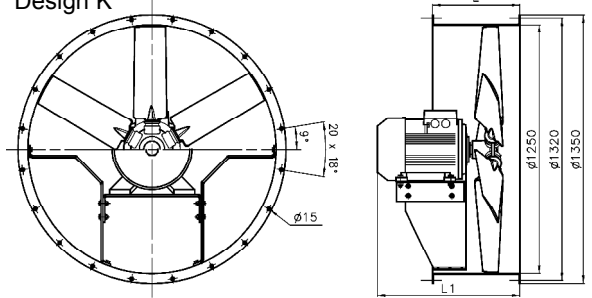

Design F

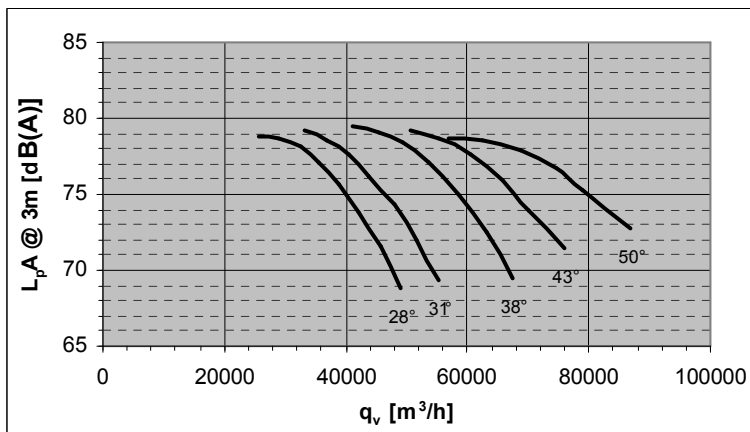
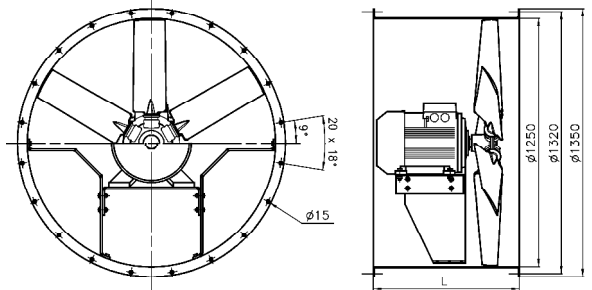

Pitch Angle	Relative spectrum							
	63	125	250	500	1000	2000	4000	8000
28°	-43	-34	-15	-7	-4	-6	-11	-21
31°	-42	-33	-15	-7	-4	-6	-10	-20
38°	-41	-32	-15	-8	-4	-6	-10	-19
43°	-41	-32	-16	-8	-4	-5	-9	-18
50°	-41	-31	-16	-8	-4	-5	-9	-17

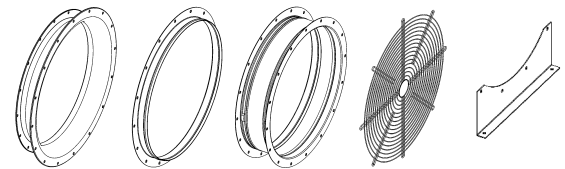

Accessories : see pages 100-102

Design	Pitch Angle	Type (G finish)	Part N°	Type (H finish)	Part N°	L1(mm)	L(mm)	Weight (kg)
K	28°	FV12V-8DK.I7.28.G	150881	FV12V-8DK.I7.28.H	150882	756	500	160
	31°	FV12V-8DK.I7.31.G	150885	FV12V-8DK.I7.31.H	150886	756	500	172
	38°	FV12V-8DK.K7.38.G	150889	FV12V-8DK.K7.38.H	150890	756	500	191
	43°	FV12V-8DK.M7.43.G	150893	FV12V-8DK.M7.43.H	150894	798	500	276
	50°	FV12V-8DK.N7.50.G	150897	FV12V-8DK.N7.50.H	150898	850	500	331
F	28°	FV12V-8DF.I7.28.G	150883	FV12V-8DF.I7.28.H	150884	---	760	183
	31°	FV12V-8DF.I7.31.G	150887	FV12V-8DF.I7.31.H	150888	---	760	195
	38°	FV12V-8DF.K7.38.G	150891	FV12V-8DF.K7.38.H	150892	---	760	214
	43°	FV12V-8DF.M7.43.G	150895	FV12V-8DF.M7.43.H	150896	---	930	316
	50°	FV12V-8DF.N7.50.G	150899	FV12V-8DF.N7.50.H	150900	---	930	371

FV14V-6D

50Hz Motor	U	I	P ₂	n	
	V	A	kW	min ⁻¹	
22°	180 L	400	29,5	15	965
27°	200 L	400	36,5	18,5	975
29°	200 L	400	43,5	22	975
32°	225 M	400	57	30	978
-	-	400	-	-	-

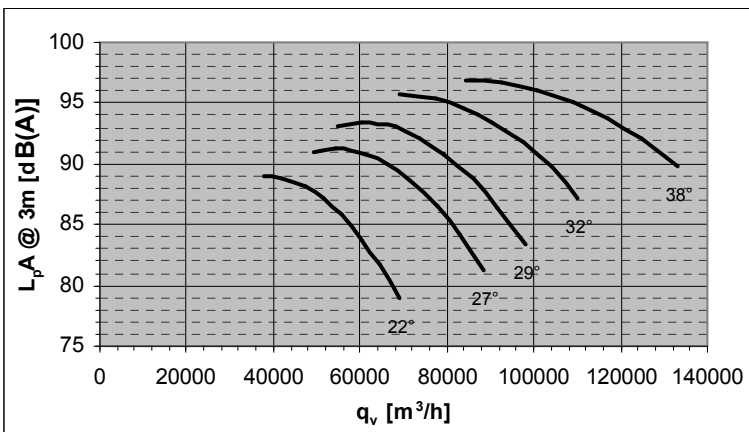
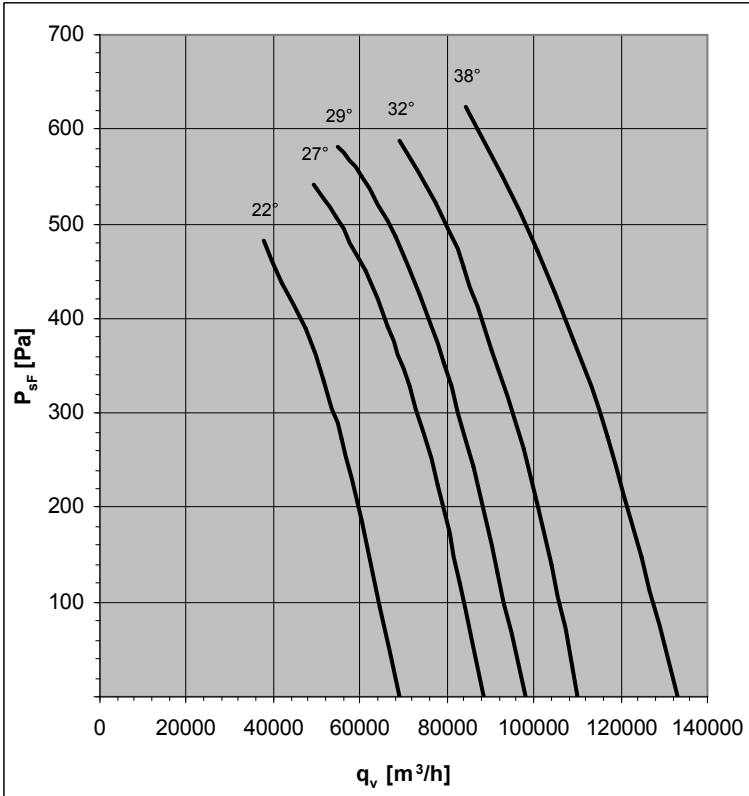

Design K

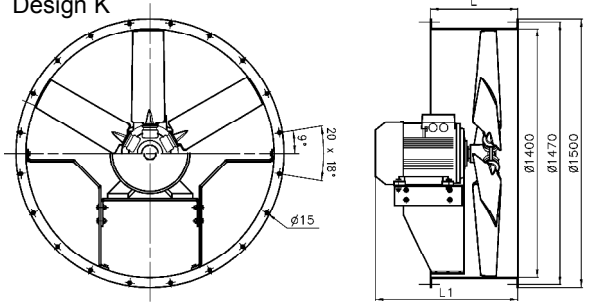

Design F

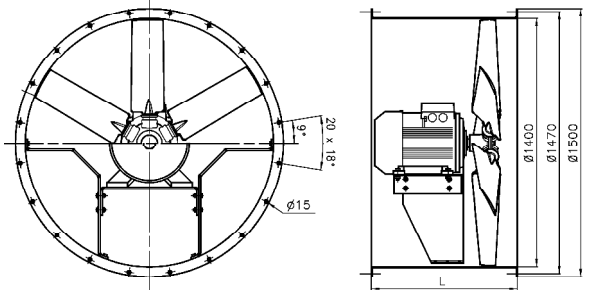

Pitch Angle	Relative spectrum							
	63	125	250	500	1000	2000	4000	8000
22°	-48	-38	-17	-8	-5	-7	-12	-23
27°	-48	-38	-17	-8	-5	-7	-12	-23
29°	-48	-37	-18	-9	-5	-6	-11	-22
32°	-48	-38	-19	-9	-5	-6	-11	-21
38°	-48	-37	-19	-9	-5	-6	-10	-21

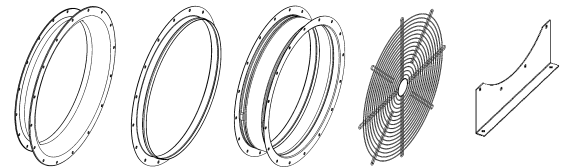

Accessories : see pages 100-102

Design	Pitch Angle	Type (G finish)	Part N°	Type (H finish)	Part N°	L1(mm)	L(mm)	Weight (kg)
K	22°	FV14V-6DK.M7.22.G	150941	FV14V-6DK.M7.22.H	150942	798	500	313
	27°	FV14V-6DK.N7.27.G	150945	FV14V-6DK.N7.27.H	150946	850	500	358
	29°	FV14V-6DK.N7.29.G	150949	FV14V-6DK.N7.29.H	150950	850	500	368
	32°	FV14V-6DK.R7.32.G	150953	FV14V-6DK.R7.32.H	150954	920	500	443
	-	-	-	-	-	---	---	---
F	22°	FV14V-6DF.M7.22.G	150943	FV14V-6DF.M7.22.H	150944	---	930	372
	27°	FV14V-6DF.N7.27.G	150947	FV14V-6DF.N7.27.H	150948	---	930	417
	29°	FV14V-6DF.N7.29.G	150951	FV14V-6DF.N7.29.H	150952	---	930	427
	32°	FV14V-6DF.R7.32.G	150955	FV14V-6DF.R7.32.H	150956	---	930	502
	-	-	-	-	-	---	---	---

Increased Temperature Range : -30°C / +60°C

FV14V-8D

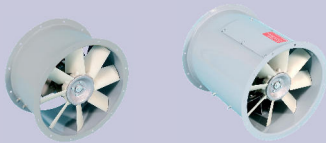

50Hz Motor	U	I	P ₂	n	
	V	A	kW	min ⁻¹	
25°	160 L	400	18,6	7,5	715
30°	180 L	400	25	11	725
36°	200 L	400	32,5	15	725
42°	225 S	400	38,5	18,5	730
47°	225 M	400	45	22	730

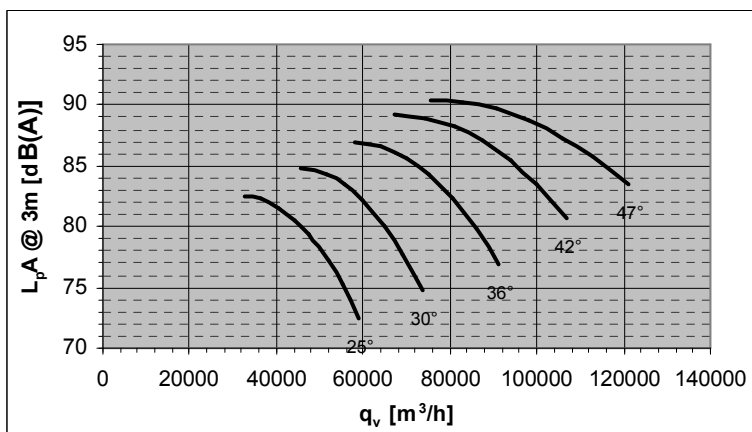
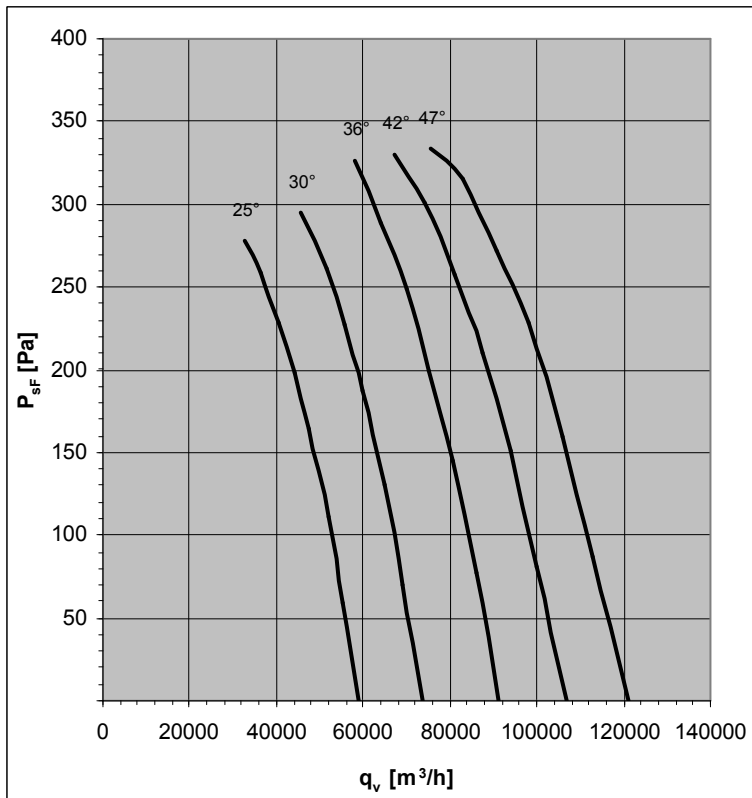

Design K

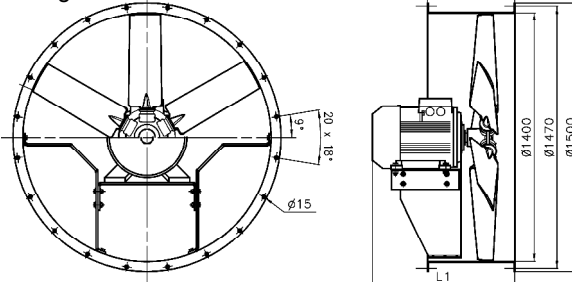

Design F

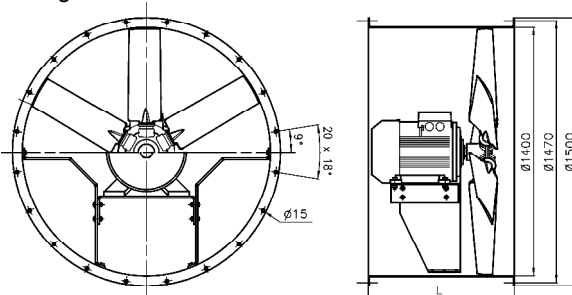

Pitch Angle	Relative spectrum							
	63	125	250	500	1000	2000	4000	8000
25°	-45	-36	-16	-8	-4	-6	-12	-22
30°	-45	-35	-16	-8	-4	-6	-11	-21
36°	-45	-35	-17	-8	-4	-6	-11	-20
42°	-45	-35	-18	-9	-5	-6	-10	-20
47°	-45	-35	-18	-9	-5	-6	-10	-19

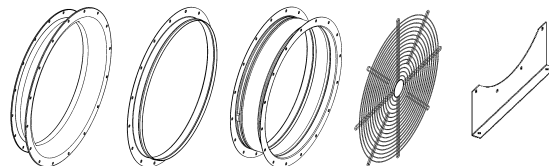

Accessories : see pages 100-102

Design	Pitch Angle	Type (G finish)	Part N°	Type (H finish)	Part N°	L1(mm)	L(mm)	Weight (kg)
K	25°	FV14V-8DK.K7.25.G	150957	FV14V-8DK.K7.25.H	150958	756	500	225
	30°	FV14V-8DK.M7.30.G	150961	FV14V-8DK.M7.30.H	150962	798	500	313
	36°	FV14V-8DK.N7.36.G	150965	FV14V-8DK.N7.36.H	150966	850	500	368
	42°	FV14V-8DK.P7.42.G	150969	FV14V-8DK.P7.42.H	150970	920	500	433
	47°	FV14V-8DK.R7.47.G	150973	FV14V-8DK.R7.47.H	150974	920	500	453
F	25°	FV14V-8DF.K7.25.G	150959	FV14V-8DF.K7.25.H	150960	---	760	260
	30°	FV14V-8DF.M7.30.G	150963	FV14V-8DF.M7.30.H	150964	---	930	372
	36°	FV14V-8DF.N7.36.G	150967	FV14V-8DF.N7.36.H	150968	---	930	427
	42°	FV14V-8DF.P7.42.G	150971	FV14V-8DF.P7.42.H	150972	---	930	492
	47°	FV14V-8DF.R7.47.G	150975	FV14V-8DF.R7.47.H	150976	---	930	512

Inlet Bellmouth / Virole d'entrée d'air / Einströmdüse / Virolas de entrada de aire

/ Boccagli d'ingresso d'aria

Part N° (G finish)	Part N° (H finish)	Type	ØA	ØB	ØC	ØD	ØE	H
00500107	00500356	FV31	315	355	372	425	395	65
00500354	00500357	FV35	355	395	425	470	450	75
00500108	00500358	FV40	400	450	470	530	500	75
00500355	00500359	FV45	450	500	530	590	560	110
00500109	00500360	FV50	500	560	590	650	620	110
00500110	00500361	FV56	560	650	620	720	690	110
00500111	00500362	FV63	630	690	720	800	770	110
00500112	00500363	FV71	710	770	800	890	860	115
00500113	00500364	FV80	800	860	890	1000	970	125
00500114	00500365	FV90	900	970	1000	1100	1070	125
00500115	00500366	FV10	1000	1070	1100	1220	1190	150
00500116	00500367	FV12	1250	1320	1350	1500	1470	180
00500117	00500368	FV14	1400	1470	1500	1720	1680	230

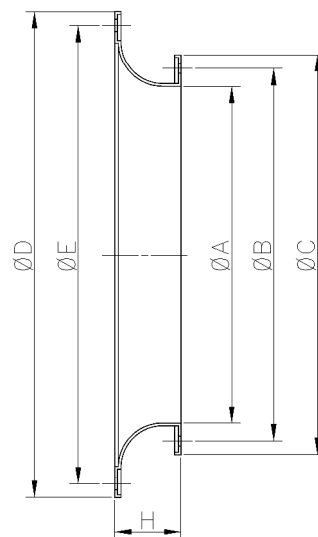

Flexible connector / Virole élastique / Elastischer stutzen / Virolas elásticas / Giunti elastici

Part N° (G finish)	Part N° (H finish)	Type	ØB	ØE	n x Ød	α	H
00500424	00500437	FV31	372	355	8 x Ø10	45°	120
00500425	00500438	FV35	425	395	8 x Ø10	45°	120
00500426	00500439	FV40	470	450	8 x Ø12	45°	120
00500427	00500440	FV45	530	500	8 x Ø12	45°	120
00500428	00500441	FV50	590	560	12 x Ø12	30°	120
00500429	00500442	FV56	650	620	12 x Ø12	30°	150
00500430	00500443	FV63	720	690	12 x Ø12	30°	150
00500431	00500444	FV71	800	770	16 x Ø12	22.5°	150
00500432	00500445	FV80	890	860	16 x Ø12	22.5°	150
00500433	00500446	FV90	1000	970	16 x Ø15	22.5°	180
00500434	00500447	FV10	1100	1070	16 x Ø15	22.5°	180
00500435	00500448	FV12	1350	1320	20 x Ø15	18°	180
00500436	00500449	FV14	1500	1470	20 x Ø15	18°	180

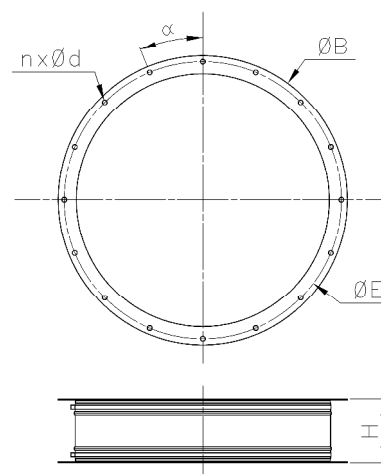

Matching flange / Contre-bride / Gegenflansche / Contrabridas / Contro-flange

Part N° (G finish)	Part N° (H finish)	Type	ØB	ØE	n x Ød	α	H
00500118	00500340	FV31	372	355	8 x Ø10	45°	35
00500093	00500341	FV35	425	395	8 x Ø10	45°	35
00500119	00500342	FV40	470	450	8 x Ø12	45°	35
00500339	00500343	FV45	530	500	8 x Ø12	45°	35
00500120	00500344	FV50	590	560	12 x Ø12	30°	35
00500121	00500345	FV56	650	620	12 x Ø12	30°	35
00500122	00500346	FV63	720	690	12 x Ø12	30°	50
00500123	00500347	FV71	800	770	16 x Ø12	22.5°	50
00500124	00500348	FV80	890	860	16 x Ø12	22.5°	50
00500125	00500349	FV90	1000	970	16 x Ø15	22.5°	50
00500126	00500350	FV10	1100	1070	16 x Ø15	22.5°	50
00500127	00500351	FV12	1350	1320	20 x Ø15	18°	50
00500128	00500352	FV14	1500	1470	20 x Ø15	18°	50

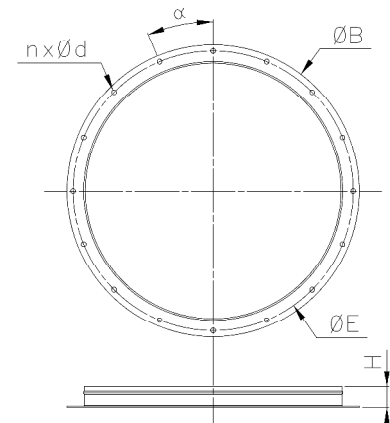

Foot / Pieds / Füße / Patas de montaje / Piedi di montaggio

Part N° (G finish)	Part N° (H finish)	Type	A	B	C	D	ØE	H	H ₁
00500129	00500370	FV31	200	40	150	20	Ø7	200	50
00500094	00500371	FV35	200	40	150	20	Ø7	230	70
00500130	00500372	FV40	330	40	280	20	Ø7	250	80
00500369	00500373	FV45	400	40	350	20	Ø7	280	125
00500131	00500374	FV50	440	60	390	40	Ø12	315	140
00500132	00500375	FV56	480	60	430	40	Ø12	355	155
00500133	00500376	FV63	530	60	480	40	Ø12	400	175
00500134	00500377	FV71	530	60	480	40	Ø18	450	160
00500135	00500378	FV80	530	80	480	50	Ø18	500	160
00500136	00500379	FV90	600	80	550	50	Ø18	560	180
00500137	00500380	FV10	660	80	610	50	Ø18	630	215
00500138	00500381	FV12	1000	80	950	50	Ø18	710	270
00500139	00500382	FV14	1100	80	1050	50	Ø18	800	310

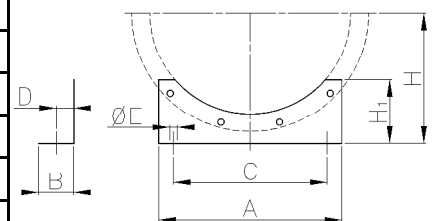

Guard grill / Grille de protection / Schutzgitter / Rejillas de protección / Griglie di protezione

Part N°	Type	ØB	ØC	ØD	E	n x α
00500140	FV31	Ø355	Ø310	Ø375	8	4 x 90°
00500141	FV35	Ø395	Ø370	Ø415	8	4 x 90°
00500142	FV40	Ø450	Ø410	Ø470	8	4 x 90°
00500143	FV45	Ø500	Ø470	Ø520	8	4 x 90°
00500144	FV50	Ø560	Ø510	Ø580	8	4 x 90°
00500145	FV56	Ø620	Ø570	Ø640	8	4 x 90°
00500146	FV63	Ø690	Ø650	Ø710	8	4 x 90°
00500147	FV71	Ø770	Ø710	Ø795	9	8 x 45°
00500148	FV80	Ø860	Ø810	Ø885	9	8 x 45°
00500149	FV90	Ø970	Ø910	Ø1010	13	8 x 45°
00500150	FV10	Ø1070	Ø1010	Ø1100	13	16 x 22.5°
00500151	FV10+B	Ø1190	Ø1130	Ø1220	13	20 x 18°
00500152	FV12	Ø1320	Ø1250	Ø1350	13	20 x 18°
00500153	FV14	Ø1470	Ø1410	Ø1500	13	20 x 18°
00500154	FV14+B	Ø1680	Ø1610	Ø1710	13	24 x 15°

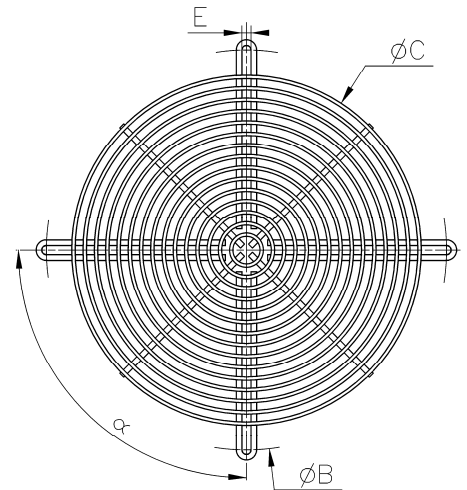

B = Inlet Bellmouth / Virole d'entrée d'air / Einströmdüse / Virolas de entrada de aire / Virole d'ingresso dell'aria

Anti-vibration mounts / Pieds anti-vibration / Schwingungs-dämpfer / Tacos antivibración

/ Giunti anti-vibranti

Part N°		A	B	C	D	ØE	ØF
032017	FV31-40	90	64	40	76	M6	8.2
032018	FV50-71	152	104	40	124	M10	10.2
032019	FV80-14	280	204	40	240	M16	14.2

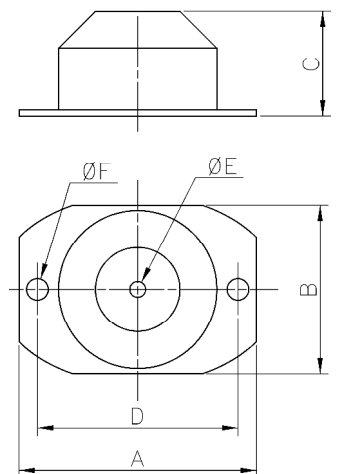

AXIAL FAN DEFINITION

Date Qty of fans per year
 Company Qty of fans per batch
 Project
 Deadline

Size: mm
 Impeller type PPG: PAG^(*) ALU
 Explosion-proof: No

Fan Selection:

Air volume m³/h
 Static pressure drop Pa
 Airflow temperature °C
 Altitude m
 Expected diameter mm
 Expected speed rotation rpm
 Expected sound level LWA(dbA)

Motor:

Supply voltage V Thermal protection PTO / PTC
 Frequency Hz 1-phase / **3-phase**
 Insulation class F^(*) or H **1 speed^(*) / 2 speeds**
 Protection class IP55^(*) Speed controllable
 Other option

Construction and installation (see catalogue drawings):

Casing Long Short
 Motor shaft position Horizontal Up Down
 Airflow direction Motor→impeller Impeller→motor
 Number of starts per day
 Specific dimensions (please attach drawing or sketch)
 Surface treatment: **Galvanized** Hot dip galvanized Other
 Paint RAL Salt fog Capability (h)

Accessories:

Set of mounting feet	Yes	<input type="checkbox"/>	No	<input type="checkbox"/>
Anti-vibrating mounts	Yes	<input type="checkbox"/>	No	<input type="checkbox"/>
flexible connection	Yes	<input type="checkbox"/>	No	<input type="checkbox"/>
Matching flange	Yes	<input type="checkbox"/>	No	<input type="checkbox"/>
Bellmouth inlet	Yes	<input type="checkbox"/>	No	<input type="checkbox"/>
Fan guard	Yes	<input type="checkbox"/>	No	<input type="checkbox"/>
Square top plate	Yes	<input type="checkbox"/>	No	<input type="checkbox"/>
Speed controller	Yes	<input type="checkbox"/>	No	<input type="checkbox"/>

(if yes: please specify dimensions)

General / Commercial:

Current solution:
 Target price:

Other informations:

(*) Standard configuration in **bolded characters**

Please refer to the homepage at
www.ziehl-abegg.com
For a list of our subsidiaries worldwide

Ziehl-Abegg FMV S.A.R.L.
Rue de la Gare, BP 8 · F-01800 VILLIEU France
Tél : 33 (0) 474 460 620, Fax : 33 (0) 474 611 958
societe@ziehl-abegg.fr www.ziehl-abegg.fr

ZIEHL-ABEGG 
Française de Motoventilateurs **FMV**