



Selection: 2-stage Semi-hermetic Reciprocating Compressors

Input Values

Compressor model	S4G-12.2Y	Suction gas temperature	20,00 °C
Refrigerant	R404A	Useful superheat	100%
Reference temperature	Dew point temp.	Power supply	400V-3-50Hz
Operating mode	with sub cooler		

Result

Q [W]	Cooling capacity	COP [-]	COP/EER
Q* [W]	Cooling capacity *	COP* [-]	COP/EER *
P [kW]	Power input	mLP [kg/h]	Mass flow LP
I [A]	Current	pm [bar(a)]	Intermed. pressure
Qc [W]	Condenser capacity		

tc	to	-25°C	-30°C	-35°C	-40°C	-45°C	-50°C	-55°C	-60°C
30°C	Q [W]	19482	16825	14267	11853	9639	7672	5979	4562
	Q* [W]	15857	13269	10913	8803	6959	5391	4094	3048
	P [kW]	9,74	9,06	8,35	7,61	6,85	6,10	5,35	4,62
	I [A]	16,99	16,09	15,14	14,19	13,26	12,36	11,53	10,79
	Qc [W]	29222	25889	22616	19462	16493	13768	11326	9180
	COP [-]	2,00	1,86	1,71	1,56	1,41	1,26	1,12	0,99
	COP* [-]	1,63	1,46	1,31	1,16	1,02	0,88	0,77	0,66
	mLP [kg/h]	386	321	263	212	166,8	128,9	97,7	72,6
	pm [bar(a)]	5,49	4,81	4,20	3,65	3,15	2,70	2,31	1,96
	40°C	Q [W]	18913	16222	13680	11331	9215	7356	5755
Q* [W]		14161	11758	9605	7714	6089	4724	3596	2677
P [kW]		11,05	10,23	9,37	8,49	7,60	6,72	5,85	5,01
I [A]		18,79	17,66	16,50	15,33	14,19	13,09	12,08	11,18
Qc [W]		29959	26450	23053	19824	16819	14074	11603	9404
COP [-]		1,71	1,59	1,46	1,33	1,21	1,10	0,98	0,88
COP* [-]		1,28	1,15	1,02	0,91	0,80	0,70	0,61	0,53
mLP [kg/h]		387	320	260	208	163,5	126,5	96,1	71,4
pm [bar(a)]		6,08	5,36	4,69	4,09	3,54	3,05	2,62	2,23
50°C		Q [W]	18060	15463	13046	10837	8855	7093	5531
	Q* [W]	12175	10080	8226	6614	5236	4069	3082	
	P [kW]	12,32	11,40	10,44	9,44	8,42	7,41	6,41	
	I [A]	20,6	19,29	17,94	16,59	15,24	13,94	12,72	
	Qc [W]	30381	26867	23483	20275	17276	14499	11938	
	COP [-]	1,47	1,36	1,25	1,15	1,05	0,96	0,86	
	COP* [-]	0,99	0,88	0,79	0,70	0,62	0,55	0,48	
	mLP [kg/h]	383	315	256	205	161,6	125,2	94,6	
	pm [bar(a)]	6,78	5,99	5,27	4,61	4,01	3,47	3,00	

-- No calculation possible (see message in single point selection)
 *According to EN12900 (20°C suction gas temp., 0K liquid subcooling)

Application Limits S4G-12.2

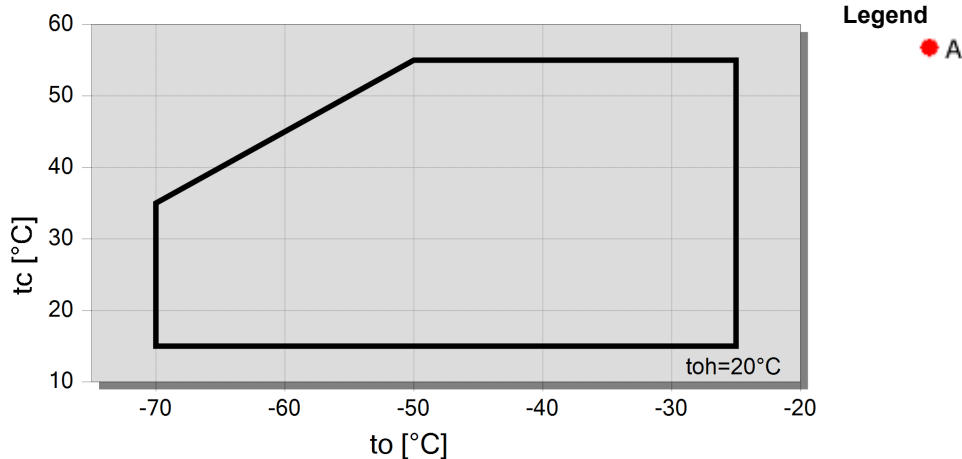



Technical Data: S4G-12.2Y

Dimensions and Connections

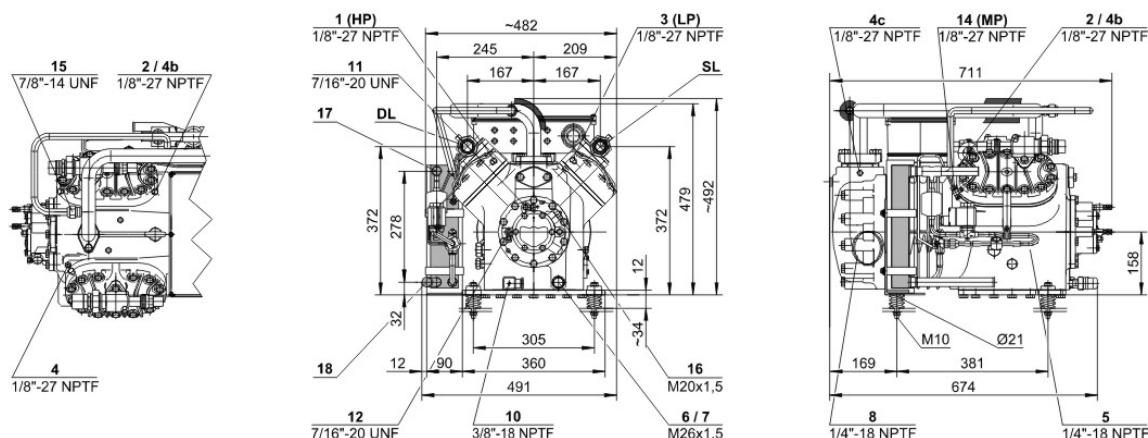

Technical Data

Technical Data

Displacement (1450 RPM 50Hz)	42.30 / 27.00 m ³ /h
Displacement (1750 RPM 60Hz)	51.05 / 32.59 m ³ /h
No. of cylinder x bore LP/HP x stroke	4 x 75/ 60 mm x 55 mm
Weight	180 kg
Max. pressure (LP/MP/HP)	19 / 19 / 28 bar
Connection suction line	35 mm - 1 3/8"
Connection discharge line	28 mm - 1 1/8"
Oil type R404A/R507A	BSE32 (Standard)
Oil type R448A/R449A	BSE32 (Standard)
Oil type R22	B5.2 (Option)

Motor data

Motor voltage (more on request)	380-420V PW-3-50Hz
Max operating current	24.0 A
Winding ratio	50/50
Starting current (Rotor locked)	69.0 A Y / 113.0 A YY
Max. Power input	13,8 kW

Extent of delivery (Standard)

Motor protection	SE-B2 (Standard)
Enclosure class	IP54 (Standard), IP66 (Option)
Vibration dampers	Standard
TX valve for liquid injection	Standard
Sight glass	Standard
Filter Drier	Standard
Solenoid valve	Standard
Oil charge	4.50 dm ³

Available Options

Crankcase heater	140 W (Option)
Oil pressure monitoring	MP54 (Option), Delta P II (Option)
Oil service valve	Option
Discharge gas temperature sensor	Option
CIC (only for R22, instead of TX valve for LI)	Option
Liquid sub cooler (also mounted)	Option



2-stage Semi-hermetic Reciprocating Compressors

Note

For R22 / R407F / R448A / R449A applications the CIC-system can be used instead of a thermostatic post-injection valve.
For R404A / R507A applications the use of the CIC-system is not recommended.

Condensing capacity

Condensing capacity: The condensing capacity can be calculated with or without heat rejection. This option can be set in the menu Program Optionen. The heat rejection is constantly 5% of the power consumption. The condensing capacity is to be found in the line Condensing cap. (with HR) resp. Condensing capacity.

Legend of connection positions according to "Dimensions":

- 1 High pressure connection (HP)
 - 2 Connection for discharge gas temperature sensor (HP) (for 4VE(S)-6Y .. 4NE(S)-20(Y) connection for CIC sensor as alternative)
 - 3 Low pressure connection (LP)
 - 4 CIC system: injection nozzle (LP)
 - 4b Connection for CIC sensor
 - 4c Connection for CIC sensor (MP / operation with liquid subcooler)
 - 5 Oil fill plug
 - 6 Oil drain
 - 7 Oil filter (magnetic screw)
 - 8 Oil return (oil separator)
 - 8* Oil return with NH₃ and insoluble oil
 - 9 Connection for oil and gas equalization (parallel operation)
 - 9a Connection for gas equalization (parallel operation)
 - 9b Connection for oil equalization (parallel operation)
 - 10 Oil heater connection
 - 11 Oil pressure connection +
 - 12 Oil pressure connection –
 - 13 Cooling water connection
 - 14 Intermediate pressure connection (MP)
 - 15 Liquid injection (operation without liquid subcooler and with thermostatic expansion valve)
 - 16 Connection for oil monitoring (opto-electrical oil monitoring "OLC-K1" or differential oil pressure switch "Delta-PII")
 - 17 Refrigerant inlet at liquid subcooler
 - 18 Refrigerant outlet at liquid subcooler
 - 19 Clamp space
 - 20 Terminal plate
 - 21 Maintenance connection for oil valve
 - 22 Pressure relief valve to the atmosphere (discharge side)
 - 23 Pressure relief valve to the atmosphere (suction side)
 - SL Suction gas line
 - DL Discharge gas line
- Dimensions can show tolerances according to EN ISO 13920-B.