



TECHNICAL DATA



# CXV Evaporative Condenser

# Technical Data

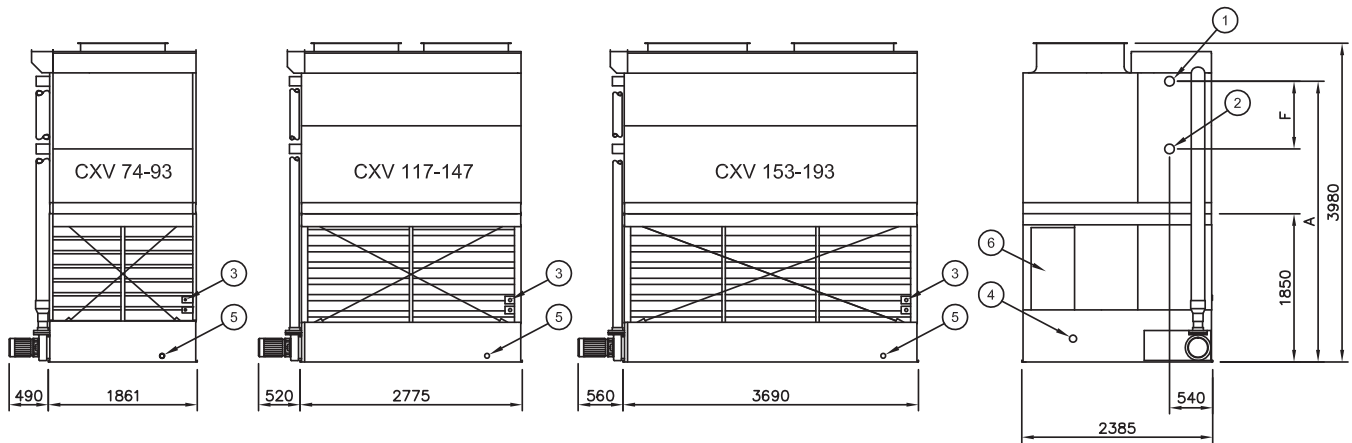

1. Refrigerant in ND 100, 2. Refrigerant out ND 100, 3. Make-up ND 15, 4. Overflow ND 80, 5. Drain ND 50, 6. Access



**Do not use for construction.** Refer to factory certified dimensions. In the interest of product improvement, specifications and dimensions are subject to change without notice.

Model Number CXV	Base Heat Rejection (kW)	Weight			Air Flow (m <sup>3</sup> /s)	Fan Motor (kW)	Spray Water Flow (l/s)	Pump Motor (kW)	R-717 Charge (kg)	Remote Sump		F (mm)
		Shipping (kg)	Operating (kg)	Heaviest Section (Coil) (kg)						Drain Size (mm)	Operating Weight (kg)	
CXV 74	319	2350	3400	1440	12.5	4.0	12	1.1	30	150	3270	845
CXV 80	345	2370	3410	1450	14.3	5.5	12	1.1	30	150	3280	845
CXV 84	362	2370	3420	1450	15.7	7.5	12	1.1	30	150	3290	845
CXV 89	383	2520	3590	1600	13.9	5.5	12	1.1	38	150	3460	1080
CXV 93	401	2530	3600	1610	15.3	7.5	12	1.1	38	150	3470	1080
CXV 117	505	3370	4980	2140	20.0	5.5	18	1.5	46	150	4830	845
CXV 123	530	3390	4980	2140	22.0	7.5	18	1.5	46	150	4840	845
CXV 131	564	3410	5000	2160	25.1	11.0	18	1.5	46	150	4860	845
CXV 137	589	3610	5240	2360	21.4	7.5	18	1.5	57	150	5090	1080
CXV 147	632	3640	5260	2390	24.5	11.0	18	1.5	57	150	5110	1080
CXV 153	661	4150	6290	2590	25.6	7.5	31.5	2.2	61	200	6030	845
CXV 164	706	4180	6310	2610	29.2	11.0	31.5	2.2	61	200	6060	845
CXV 173	744	4190	6320	2620	32.1	15.0	31.5	2.2	61	200	6070	845
CXV 184	795	4480	6650	2910	28.6	11.0	31.5	2.2	76	200	6400	1080
CXV 193	832	4490	6660	2920	31.4	15.0	31.5	2.2	76	200	6410	1080

# Technical Data

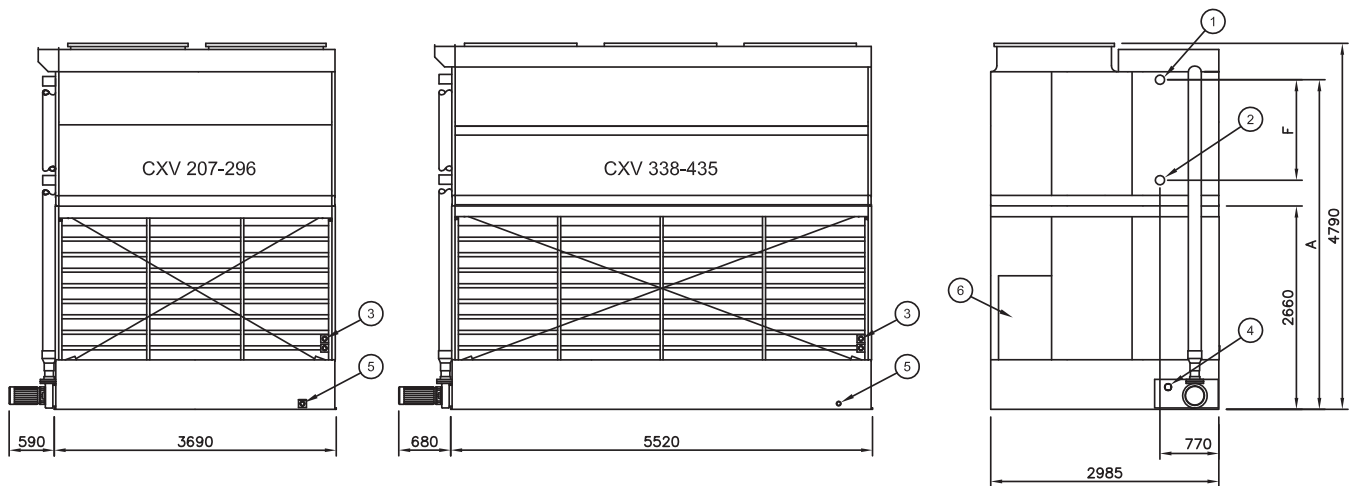

1. Refrigerant in ND 100, 2. Refrigerant out ND 100, 3. Make-up ND 25, 4. Overflow ND 80, 5. Drain ND 50, 6. Access



**Do not use for construction.** Refer to factory certified dimensions. In the interest of product improvement, specifications and dimensions are subject to change without notice.

Model Number CXV	Base Heat Rejection (kW)	Weight			Air Flow (m <sup>3</sup> /s)	Fan Motor (kW)	Spray Water Flow (l/s)	Pump Motor (kW)	R-717 Charge (kg)	Remote Sump		F (mm)
		Shipping (kg)	Operating (kg)	Heaviest Section (Coil) (kg)						Drain Size (mm)	Operating Weight (kg)	
CXV 207	892	4560	6970	2830	38.0	18.5	38	3.0	69	200	6718	610
CXV 214	918	4570	6980	2840	40.4	22.0	38	3.0	69	200	6727	610
CXV 229	987	4970	7450	3240	31.7	11.0	38	3.0	91	200	7191	845
CXV 241	1034	4970	7450	3250	34.9	15.0	38	3.0	91	200	7195	845
CXV 253	1086	5000	7480	3270	37.6	18.5	38	3.0	91	200	7223	845
CXV 258	1112	5010	7490	3280	39.9	22.0	38	3.0	91	200	7232	845
CXV 269	1159	5410	7950	3690	33.9	15.0	38	3.0	114	200	7700	1080
CXV 280	1202	5440	7980	3710	36.5	18.5	38	3.0	114	200	7723	1080
CXV 288	1241	5450	7990	3720	38.8	22.0	38	3.0	114	200	7736	1080
CXV 296	1275	5890	8500	4160	38.1	22.0	38	3.0	136	200	8241	1314
CXV 338	1452	7070	10810	4670	47.9	11 & 5.5	52	5.5	136	200	10555	845
CXV 354	1525	7090	10820	4680	52.7	15 & 7.5	52	5.5	136	200	10568	845
CXV 369	1585	7140	10870	4730	56.7	18.5 & 11	52	5.5	136	200	10618	845
CXV 379	1633	7150	10880	4740	60.3	22 & 11	52	5.5	136	200	10627	845
CXV 396	1702	7760	11590	5350	51.2	15 & 7.5	52	5.5	170	200	11132	1080
CXV 411	1771	7810	11640	5400	55.1	18.5 & 11	52	5.5	170	200	11386	1080
CXV 424	1822	7820	11650	5410	58.6	22 & 11	52	5.5	170	200	11395	1080
CXV 435	1874	8490	12410	6090	57.5	22 & 11	52	5.5	201	200	12155	1314

# Technical Data

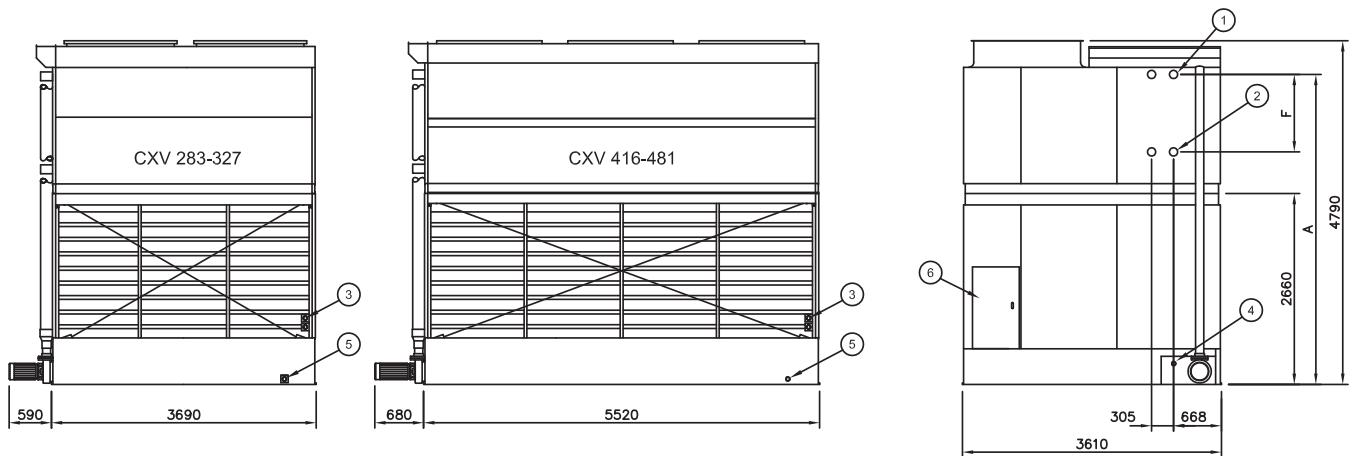

1. Refrigerant in ND 100, 2. Refrigerant out ND 100, 3. Make-up ND 25, 4. Overflow ND 80, 5. Drain ND 50, 6. Access



**Do not use for construction.** Refer to factory certified dimensions. In the interest of product improvement, specifications and dimensions are subject to change without notice.

Model Number CXV	Base Heat Rejection (kW)	Weight			Air Flow (m <sup>3</sup> /s)	Fan Motor (kW)	Spray Water Flow (l/s)	Pump Motor (kW)	R-717 Charge (kg)	Remote Sump		F (mm)
		Shipping (kg)	Operating (kg)	Heaviest Section (Coil) (kg)						Drain Size (mm)	Operating Weight (kg)	
CXV 283	1219	5850	9050	3960	35.0	11.0	45.1	4.0	123	200	8800	1080
<b>CXV 297</b>	<b>1280</b>	<b>5850</b>	<b>9080</b>	<b>3990</b>	<b>38.5</b>	<b>15.0</b>	<b>45.1</b>	<b>4.0</b>	<b>123</b>	<b>200</b>	<b>8823</b>	<b>1080</b>
CXV 309	1331	5900	9100	4010	41.5	18.5	45.1	4.0	123	200	8845	1080
CXV 327	1409	6380	9650	4490	43.1	22.0	45.1	4.0	146	200	9395	1314
CXV 416	1792	8400	13230	5750	53.0	11 & 5.5	53.6	5.5	182	200	12936	1080
CXV 437	1883	8440	13270	5790	58.3	15 & 7.5	53.6	5.5	182	200	12977	1080
CXV 454	1956	8490	13320	5840	62.8	18.5 & 11	53.6	5.5	182	200	13014	1080
CXV 468	2016	8500	13330	5850	66.7	22 & 11	53.6	5.5	182	200	13064	1080
CXV 481	2072	9220	14150	6570	65.3	22 & 11	53.6	5.5	216	200	13882	1314

**NOTES:****APPLICABLE ON ALL MODELS**

1. The standard right hand arrangement as shown has the air inlet side on the right when facing the connection end. Left hand can be furnished by special order. Pump and refrigerant connections are always located on the same end of the unit.
2. Standard refrigerant in-and outlet connection sizes are ND100, beveled for welding for all CXV models. Other connection sizes are available on special order.
3. Fan motor sizes shown in the table are for 0 mm external static pressure (ESP).
4. Refrigerant charge listed is R717 operating charge. To determine operating charge for R22, multiply charge by 1.93 and for R134A by 1.98.
5. Operating weight shown in the tables is based on total unit weight, weight of refrigerant operating charge and basin filled to overflow level.

# Structural Support

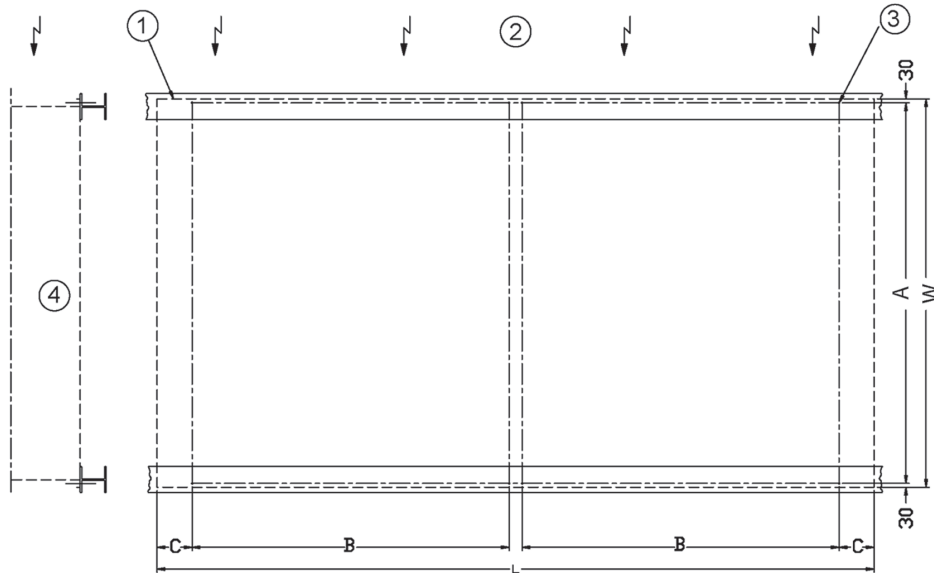

Model Number CXV	Max. Deflection (mm) (4)	Dimensions (mm)					No. of 16 mm Anchor bolts
		W	L	A	B	C	
74 - 93	5	2385	1860	2325	-	255	4
117 - 147	8	2385	2775	2325	-	255	4
153 - 193	10	2385	3690	2325	-	255	4
207 - 296	10	2985	3690	2925	-	255	4
<b>283 - 327</b>	<b>10</b>	<b>3610</b>	<b>3690</b>	<b>3550</b>	<b>2440</b>	<b>255</b>	<b>4</b>
338 - 435	12	2985	5520	2925	2440	270	8
416 - 481	12	3610	5520	3550	2440	270	8



## NOTES:

- Support beams and anchor bolts to be selected and installed by others.
- All support steel must be level at the top.
- Beams must be selected in accordance with accepted structural practice.
- Maximum deflection is for units with water level in pan at overflow.
- Consult your BAC representative for the weight loading diagram before selecting support beams.



# CXV Questions?

---

VISIT [WWW.BALTIMOREAIRCOIL.COM.AU](http://WWW.BALTIMOREAIRCOIL.COM.AU):

OR CALL 1300 134 662 (AUSTRALIA)  
0800 225 842 (NEW ZEALAND)



**BALTIMORE  
AIRCOIL AUSTRALIA**

COOLING TOWERS

---

CLOSED CIRCUIT COOLING TOWERS

---

ICE THERMAL STORAGE

---

EVAPORATIVE CONDENSERS

---

HYBRID PRODUCTS

---

PARTS & SERVICES

[www.BaltimoreAircoil.com.au](http://www.BaltimoreAircoil.com.au)

120 Wisemans Ferry Road, Somersby NSW 2250 > Telephone (Australia): 1300.134.622 > Telephone (New Zealand): 0800.225.842