

HGX6/1410-4 S

Engine: 380-420V Y/YY -3- 50Hz PW

Refrigerant: R404A, R507

Subject: HGX6/1410-4 S

Performance data

Application: Refrigeration & AC

Refrigerant	R404A, R507	Compressor refrigeration capacity	76.90 kW
Reference temperature	Dew point	Evaporator refrigeration capacity	75.00 kW
Power supply	50 Hz, 400 V	Power consumption	31.50 kW
Supply frequency	50 Hz	Current draw (400 V)	58.90 A
Evaporating temperature	-5.0 °C	Coefficient of performance (COP/EER)	2.44
<i>Evaporating pressure (abs.)</i>	<i>5.14 bar</i>	Condensing capacity	109.00 kW
Condensing temperature	40.0 °C	Mass flow	0.681 kg/s
<i>Condensing pressure (abs.)</i>	<i>18.17 bar</i>	Discharge end temperature	70.1 °C ¹⁾
Suction gas superheat	10 K		
Subcooling (outside cond.)	0 K		
Usable superheat	7 K		

Certifications



ASERCOM certified performance data

The performance data of compressors bearing this label has been certified to the strict requirements of ASERCOM.

ASERCOM is the Association of European Refrigeration Compressors and Controls Manufacturers. Information about the Association and the constantly updated overview of certified Bock compressors can be found at www.asercom.org.

This certification is based on EN 12900. This signifies: 20 °C suction gas temperature without liquid subcooling at 50 Hz power supply frequency.

¹⁾ The stated value of the discharge end temperature is a mere calculated value. Additional cooling and heat dissipation are not considered. Deviations (particularly in deep freezing applications) from the real measured discharge temperature during operation are possible.

Subject to change without notice

To:

From:

22.03.2022
Page 1 of 7

VAP 11.10.0

HGX6/1410-4 S



Engine: 380-420V Y/YY -3- 50Hz PW

Refrigerant: R404A, R507

Subject: HGX6/1410-4 S

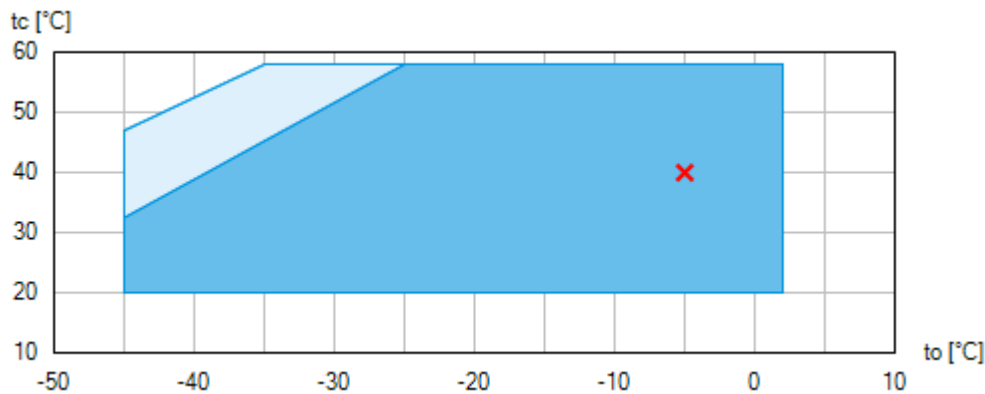
Operating limits



-  Unlimited application range
-  Supplementary cooling or reduced suction gas temperature ($\Delta t_{oh} < 20K$)

Compressor operation is possible within the limits shown on the diagrams of application. Please note the coloured areas. Compressor application limits should not be chosen for design purposes or continuous operation. Axis values refer to dew point (saturated vapour line).

Subject to change without notice

To:

From:

22.03.2022
Page 2 of 7

VAP 11.10.0

HGX6/1410-4 S

Engine: 380-420V Y/YY -3- 50Hz PW

Refrigerant: R404A, R507

Subject: HGX6/1410-4 S

Technical data

Number of cylinders / Bore / Stroke	4 / 80 mm / 70 mm
Displacement 50/60 Hz (1450/1740 ¹ /min)	122,40 / 146,90 m ³ /h
Voltage ¹⁾	380-420V Y/YY -3- 50Hz PW
	440-480V Y/YY -3- 60Hz PW
Winding divided into	66% / 33%
Max. working current ²⁾	76.0 A
Max. power consumption ²⁾	42.3 kW
Starting current (rotor blocked) ²⁾	204.0 / 250.0 A
Motor protection	MP10
Protection terminal box	IP 65
Weight	222 kg
Max. permissible overpressure (g) (LP/HP) ³⁾	19 / 28 bar
Connection suction line SV	54 mm - 2 1/8 "
Connection discharge line DV	35 mm - 1 3/8 "
Lubrication	Oil pump
Oil type R134a, R404A, R407A/C/F, R448A, R449A, R450A, R513A	BOCKlub E55
Oil type R22	BOCKlub A46
Oil charge	3,6 Ltr.
Oil sump heater	230 V - 1 - 50/60 Hz, 140 W
Dimensions Length / Width / Height	850 / 455 / 405 mm

1) Tolerance ($\pm 10\%$) relates to the mean value of the voltage range. Other voltages and current types on request

All data are based on voltage rms values

PW = part winding, motors for part winding starting
(no start unloaders required)
Designs for Y/D on request

2) - The stated value for the max. power consumption is valid for the adjusted power supply.

- Starting current (rotor blocked):

- Part winding (PW) motors: Winding 1 / Winding 1+2
- Delta/Star (Δ/Y) motors: Δ / Y

- Take account of the max. operating current / max. power consumption for designing motor contractors, feed lines, fuses and motor protection switches. Motor contractors: Consumption category AC3.

3) LP = Low pressure
HP = High pressure

Subject to change without notice

To:

From:

22.03.2022
Page 3 of 7

VAP 11.10.0

HGX6/1410-4 S

Engine: 380-420V Y/YY -3- 50Hz PW

Refrigerant: R404A, R507

Subject: HGX6/1410-4 S

Performance data table

Application: Refrigeration & AC

Reference temperature: Dew point

Supply frequency: 50 Hz

Voltage: 400 V

Suction gas superheat: 10 K

Subcooling (outside cond.): 0 K

tc [°C]		to [°C]									
		5.0	0.0	-5.0	-10.0	-15.0	-20.0	-25.0	-30.0		
30.0	Q [W]		111000	91600	74900	60400	48100	37600	28900		
	P [kW]		28.90	27.50	25.90	23.90	21.80	19.50	17.20		
	I [A]		55.30	53.50	51.20	48.80	46.20	43.60	41.10		
35.0	Q [W]		103000	84300	68600	55200	43700	34000	26000		
	P [kW]		31.40	29.60	27.50	25.20	22.70	20.20	17.60		
	I [A]		58.80	56.20	53.40	50.40	47.30	44.30	41.50		
40.0	Q [W]		93800	76900	62400	49900	39400	30500	23100		
	P [kW]		33.70	31.50	29.00	26.40	23.60	20.70	17.90		
	I [A]		62.10	58.90	55.50	51.90	48.40	45.00	41.80		
45.0	Q [W]		85300	69600	56200	44700	35100	27000	20300		
	P [kW]		35.90	33.20	30.40	27.40	24.30	21.20	18.10		
	I [A]		65.30	61.40	57.30	53.20	49.30	45.50	42.10		
50.0	Q [W]		76800	62300	50000	39500	30800	23500	17500		
	P [kW]		37.90	34.80	31.60	28.30	24.90	21.60	18.30		
	I [A]		68.40	63.80	59.10	54.50	50.00	45.90	42.30		
55.0	Q [W]		68400	55000	43800	34400	26500	20100	14800		
	P [kW]		39.70	36.30	32.70	29.10	25.40	21.80	18.40		
	I [A]		71.30	66.00	60.70	55.50	50.70	46.30	42.30		

 Supplementary cooling or reduced suction gas temperature ($\Delta t_{oh} < 20K$)

to Evaporating temperature

tc Condensing temperature

Q Compressor refrigeration capacity

P Power consumption

I Current draw

Subject to change without notice

To:

From:

22.03.2022
Page 4 of 7

VAP 11.10.0

HGX6/1410-4 S

Engine: 380-420V Y/YY -3- 50Hz PW

Refrigerant: R404A, R507

Subject: HGX6/1410-4 S

Dimensions and connections

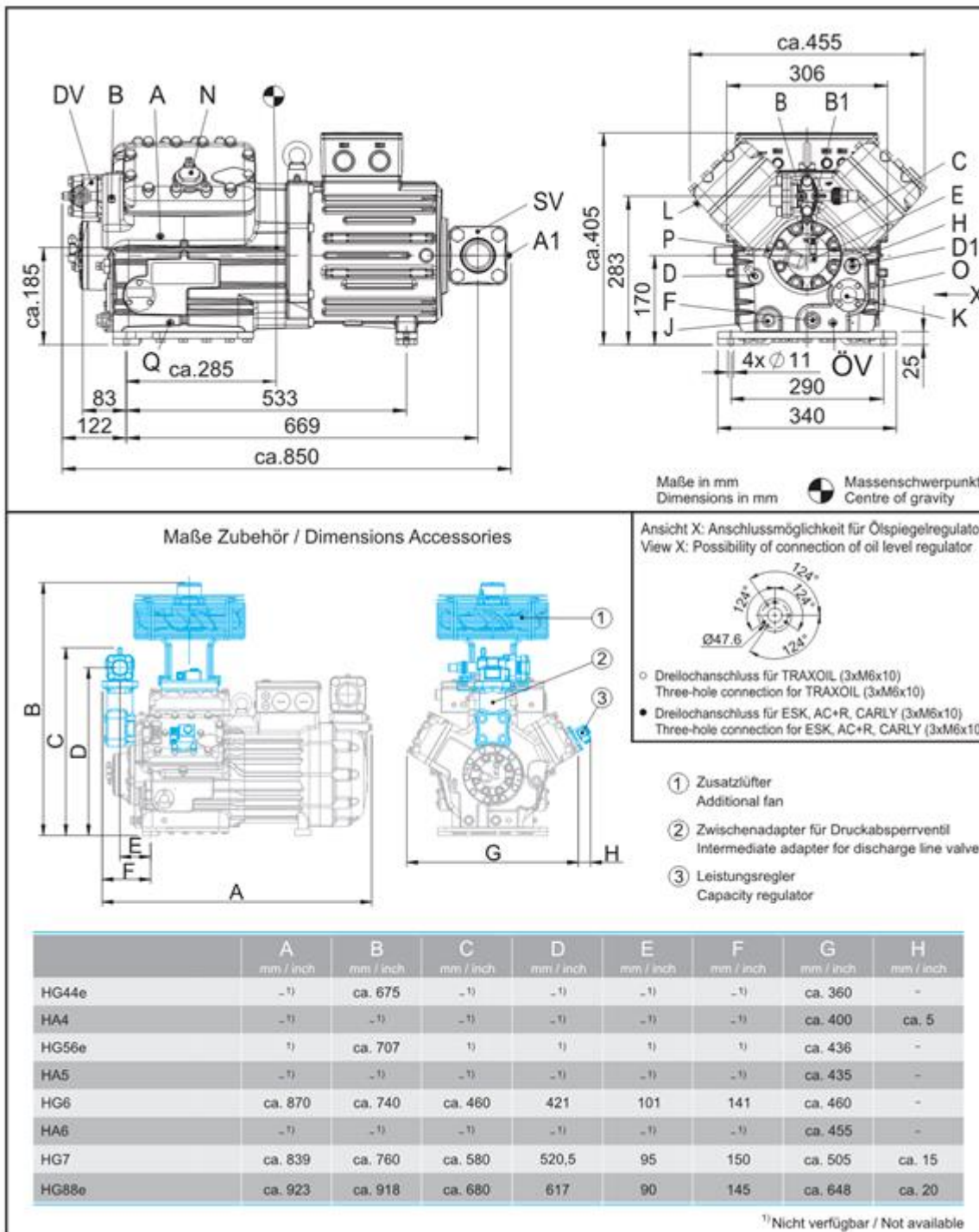

Subject to change without notice

To:

From:

22.03.2022
Page 5 of 7

VAP 11.10.0

HGX6/1410-4 S

Engine: 380-420V Y/YY -3- 50Hz PW

Refrigerant: R404A, R507

Subject: HGX6/1410-4 S

SV	Suction line valve, tube \varnothing ¹⁾	54 mm - 2 1/8 "
DV	Discharge line valve, tube \varnothing ¹⁾	35 mm - 1 3/8 "
A	Connection suction side, not lockable	1/8 " NPTF
A1	Connection suction side, lockable	7/16 " UNF
B	Connection discharge side, not lockable	1/8 " NPTF
B1	Connection discharge side, lockable	7/16 " UNF
C	Connection oil pressure safety switch OIL	7/16 " UNF
D	Connection oil pressure safety switch LP	7/16 " UNF
D1	Connection oil return from oil separator	1/4 " NPTF
E	Connection oil pressure gauge	7/16 " UNF
F	Oil drain	M 22 x 1.5
H	Oil charge plug	M 22 x 1.5
J	Connection oil sump heater	M 22 x 1.5
K	Sight glass	-
L	Connection thermal protection thermostat	1/8 " NPTF
N	Connection capacity regulator	M 45 x 1.5
O	Connection oil level regulator	3 x M 6
ÖV	Connection oil service valve	1/4" NPTF
P	Connection oil differential pressure sensor	M 20 x 1.5
Q	Connection oil temperature sensor	1/8" NPTF

1) Brazing connection

Subject to change without notice

To:

From:

22.03.2022
Page 6 of 7

VAP 11.10.0

HGX6/1410-4 S

Engine: 380-420V Y/YY -3- 50Hz PW

Refrigerant: R404A, R507

Subject: HGX6/1410-4 S

Product photo



Subject to change without notice

To:

From:

22.03.2022
Page 7 of 7

VAP 11.10.0