



BITZER Output data

Created on : 22.01.2021 10:46:51



Table of content

Selection: Open Screw Compressors OS.....	3
Technical Data: OSKA7452-K.....	5
Information: Open Screw Compressors OS.....	6



Selection: Open Screw Compressors OS

Input Values

Compressor model	OSKA7452-K	Operating mode	Standard
Refrigerant	R717	Speed	2900 /min
Reference temperature	Dew point temp.	Useful superheat	100%
Liq. subc. (in condenser)	0 K	Additional cooling	Automatic
Suct. gas superheat	1,00 K	Max. discharge gas temp.	80,0 °C

Result

Q [W]	Cooling capacity	Qac [kW]	Additional cooling
P [kW]	Power input	tcu [°C]	Liquid temp.
COP [-]	COP/EER	pm [bar(a)]	ECO pressure
mLP [kg/h]	Mass flow LP	Qsc [kW]	sub cooler capacity (ECO)
mHP [kg/h]	Mass flow HP		

tc	to	10°C	5°C	0°C	-5°C	-10°C	-15°C	-20°C	-25°C
30°C	Q [W]	282251	236797	197075	162500	132517	106589	84194	--
	P [kW]	36,8	37,9	37,6	36,5	35,1	33,7	32,9	
	COP [-]	7,66	6,25	5,24	4,45	3,78	3,17	2,56	
	mLP [kg/h]	897	756	632	523	429	347	276	
	mHP [kg/h]	897	756	632	523	429	347	276	
	Qac [kW]	--	5,28	9,48	12,41	14,58	16,51	18,73	
	tcu [°C]	30,0	30,0	30,0	30,0	30,0	30,0	30,0	
	pm [bar(a)]	--	--	--	--	--	--	--	
	Qsc [kW]	--	--	--	--	--	--	--	
40°C	Q [W]	269256	224505	185519	151746	122668	97804	--	--
	P [kW]	49,3	48,4	47,0	45,5	44,1	43,4		
	COP [-]	5,46	4,64	3,95	3,34	2,78	2,26		
	mLP [kg/h]	894	748	621	511	415	333		
	mHP [kg/h]	894	748	621	511	415	333		
	Qac [kW]	15,82	19,41	22,1	24,2	26,2	28,4		
	tcu [°C]	40,0	40,0	40,0	40,0	40,0	40,0		
	pm [bar(a)]	--	--	--	--	--	--		
	Qsc [kW]	--	--	--	--	--	--		
50°C	Q [W]	250568	207123	169486	137159	109697	--	--	--
	P [kW]	61,3	59,5	58,2	57,4	57,2			
	COP [-]	4,09	3,48	2,91	2,39	1,92			
	mLP [kg/h]	871	723	594	484	389			
	mHP [kg/h]	871	723	594	484	389			
	Qac [kW]	33,7	35,6	37,8	40,1	42,7			
	tcu [°C]	50,0	50,0	50,0	50,0	50,0			
	pm [bar(a)]	--	--	--	--	--			
	Qsc [kW]	--	--	--	--	--			

-- No calculation possible (see message in single point selection)

*According to EN12900 (5K suction gas superheat, 0K liquid subcooling)

Application Limits Standard OSKA7451

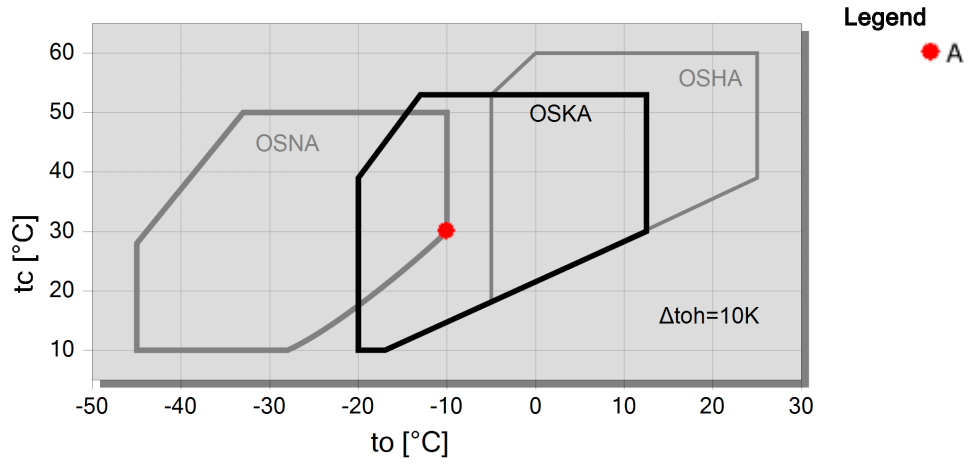



Technical Data: OSKA7451-K

Dimensions and Connections

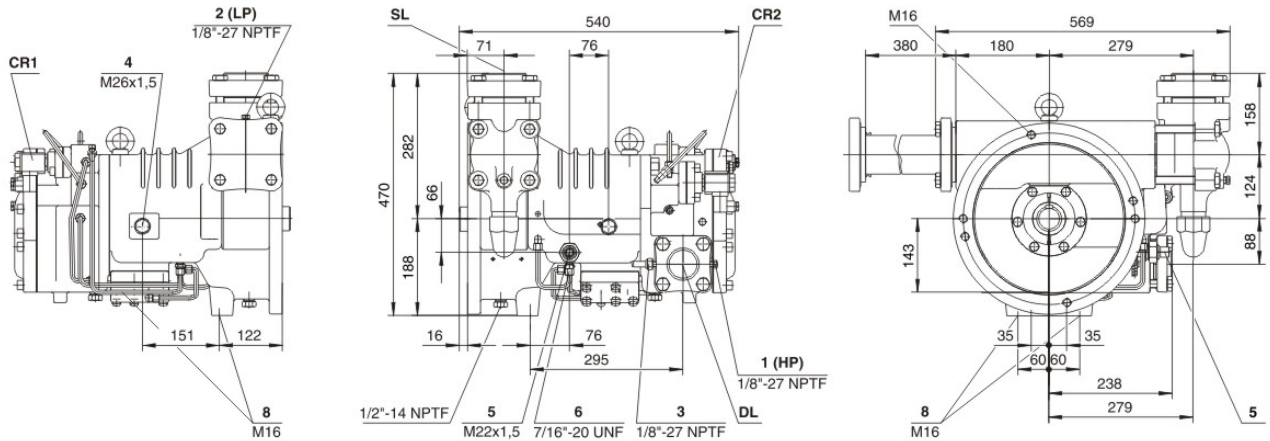

Technical Data

Technical Data

Displacement (2900 RPM 50 Hz)	192 m ³ /h
Displacement (3500 RPM 60 Hz)	232 m ³ /h
Allowed speed range	1450 .. 4000 min ⁻¹
Sens of rotation (compressor)	links / counter-clockwise
Weight	176 kg
Max. pressure (LP/HP)	19 / 28 bar
Connection suction line	76 mm - 3 1/8"
Connection suction line (NH3)	DN 80
Connection discharge line	54 mm - 2 1/8"
Connection discharge line (NH3)	DN 50
Adapter for ECO (NH3)	DN 20 (Option)
Oil type NH3	Reniso KC68 , SHC 226E

Extent of delivery (Standard)

Suction shut-off valve	Standard
Pressure relief valve	Standard
Check valve	Standard
Oil injection kit	Standard
Built in oil filter	Standard
discharge gas temperature monitoring	SE-B2
Discharge gas temperature sensor	Standard
Start unloading	Standard
Capacity control	100-75-50% (Standard)
Protective charge	Standard

Available Options

Oil flow control	Option
Discharge shut-off valve	Option
ECO connection with shut-off valve	Option
Coupling housing	Option



Open Screw Compressors OS

OSK = Application for air-conditioning and medium temperature cooling.

OSN = Application for low temperature cooling.

OSH = Application for air-conditioning and heat pumps.

Notes regarding application limits (see "T.Data - Limits")

* Ranges are valid for standart operation and at full-load conditions.

* With high pressure conditions, part-laod operation is partly limited (see application limits in applications manual SH-500/SH-510).

* With Economizer operation the maximum admissible evaporation temperature is shifted by 10K downward (otherwise there is a danger of excessive compression and overlaod of the motor because of a higher mass flow). At pull-down conditions from higher evaporation temperatures, the ECO injection must remain closed until the evaporation temperature is below the maximum admissible value and a stable operation is achieved (e.g. control of the ECO solenoid valve by means of a low pressure cut-out). The use of the ECO-System with higher evaporation temperatures requires individual consultation with Bitzer.

OS53..OS74

* Capacity control with ECO operation at the same time is limited to one single regulating step (CR 75%). At CR 50% the ECO injection should be closed.

* Combined operation (ECO + CR 50%) is possible under certain conditions, control and system design, however, require individual consultation with Bitzer.

Motor Selection

The required driving motor is selected for starting conditions at direct start as well as at star-delta-start with start unloading (50% capcaity regulation). The starting conditions refer to the following defined operation points resp. to the maximum application limit of the compressor. Should the evaporation- or the condensing temperature of the plant be higher at the start, an individual motor selection is necessary.

Evaporation temperature for motor selection				
	HH	H	M	L
R134a	+20 °C	+12,5 °C	-5 °C	
R404A / R507A		+7,5 °C	-5 °C	-15 °C
R22		+12,5 °C	-5 °C	-10 °C
R407C		+12,5 °C	-5 °C	
NH ₃	+25 °C	+12,5 °C	-5 °C	-10 °C

The stated motor data refer to IEC motors at which the pull-up torque should not fall below 90% of the max. torque. In addition the following starting torque (referring to direct start) must be reached:

* open screw compressors 120%

Should the motor not fulfil these criteria, an individual selection is also necessary.

Lubricants and additional cooling for NH3 applications

	Type	Viscosity	Discharge gas temp. (°C)	Oil injection temp. (°C)
Reniso KM32	MO	32	ca. 60 .. max. 100	max. 50
Reniso KS46	MO	46	ca. 60 .. max. 80 (100 [1])	max. 60
Reniso KC68	MO	68		
Reflo 68A	MO (HT)	58		
SHC226E	PAO	68		

[1] 100°C only after consultation with BITZER

Further information on the selection of lubricants can be found in the Application Manuals SH-500 and SH-510.

Legend of connection positions according to "Dimensions":



- 1 High pressure connection (HP)
 - 1a Additional high pressure connection
 - 1b Connection for high pressure transmitter (HP)
 - 2 Low pressure connection (LP)
 - 2a Additional low pressure transmitter (LP)
 - 2b Connection for low pressure transmitter (LP)
 - 3 Discharge gas temperature sensor connection (HP)
 - 4 Connection for economiser (ECO)
 - HS.85: ECO valve with connection pipe (option)
 - HS.95, OS.85, OS.95: ECO valve (option)
 - 5 Oil injection connection
 - 6 Oil pressure connection for HS.85 and OS.85:
Oil drain (compressor housing)
 - 7 Oil drain (motor housing)
 - 7a Oil drain (suction gas filter)
 - 7b Oil drain out of shaft seal (maintenance connection)
 - 7c Oil drain tube (shaft seal)
 - 8 Threaded bore for foot fastening
 - 9 Threaded bore for pipe support (ECO and LI line)
 - 10 Maintenance connection (oil filter)
 - 11 Oil drain (oil filter)
 - 12 Monitoring of oil stop valve
 - OS.85: Monitoring rotation direction and oil stop valve
 - 13 Oil filter monitoring
 - 14 Oil flow switch
 - 15 Earth screw for housing
 - 16 Pressure relief (oil filter chamber)
 - 17 Maintenance connection for shaft seal
 - 18 Liquid injection (LI)
 - 19 Compressor module
 - 20 Slider position indicator
 - 21 Oil level switch
 - 22 Connection for oil pressure transmitter
 - 23 Connection for oil and gas return
(for systems with flooded evaporator adaptor optional)
 - 24 Acces to oil circulation restrictor
 - SL Suction gas line
 - DL Discharge gas line
- Dimensions can show tolerances according to EN ISO 13920-B.