



Compressor
Voltage Code : HZ

CAJ9513T-HZ

High Temp. Commercial (MHP)

208 - 220V 1~ 60 Hz

R22

AJK513T-HZ3C

Conditions	Frequency	Nominal Cooling Capacity		Sound Power ISO3745 / ISO 3743-1
		Watts	BTU/h	
ARI 520-90 / R22	60 Hz	2185	7452	

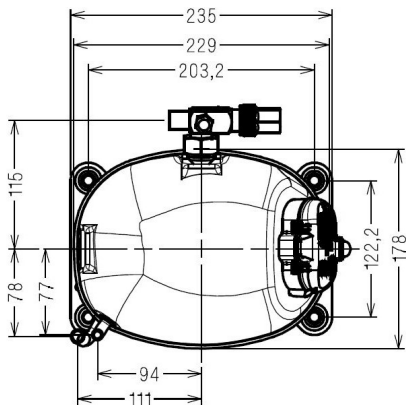
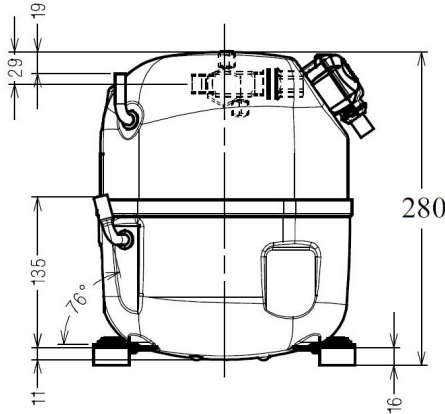

* ARI 520-90 : T°Cond. 48.9°C / T°Evap. -6.7°C / T°Return gas temp.. 4.4°C
T°Subcooling. 0.0K

Certificates :



Displacement (cc)	24,2
Net Weight (Kg)	22.2
Oil Quantity (cc)	475.0
Oil Type	Synthetic_Alkylate
Expansion Device	Capillary_Tube/Expansion_Valve
Cooling	Fan
Main Winding (Ohm)	1.3
Start Winding (Ohm)	4.5
Current	
RLA (A)	7.6
MCC (A)	12.5
LRA (A)	40
Electrical Equipment	CSR
Overload	T0889
Time Check	7.5s - 14s / 23.5 A
Open Temp	150° C
Close Temp	61° C
Start Capacitor	88 µF / 330 V
Run Capacitor	15 µF / 400 V
Potential Relay	RVA2AL**
Pick Up	224/252V
Drop Out	40/105V
Refrigerating connection for OD	
Suction Tube	15.9 (5/8")
Discharge Tube	7.9 (5/16")
Process Tube	6.35 (1/4")

Note : Tecumseh reserves the right to change information contained in this document without notification.



Tecumseh

CAJ9513T-HZ	Tension HZ : 208 - 220V 1~ 60 Hz
--------------------	---

Les performances sont données dans les conditions ARI 520-90 :	Gaz aspirés :	4.4 °C
Condition Dew	Sous refroidissement :	0.0 K
The performance data are in ARI 520-90 conditions :	Return gas :	4.4 °C
Dew Condition	Subcooling :	0.0 K

60 Hz R22

N°2526

4 T condensation	5 T évaporation	(°C)	-20	-15	-10	-5	0
40	1 P frigorifique	(Watt)	1339	1731	2188	2722	3346
	2 P absorbée	(W)	872	970	1070	1170	1266
	3 I absorbée	(A)	4.32	4.80	5.26	5.71	6.15
50	1 P frigorifique	(Watt)	1077	1432	1838	2306	2848
	2 P absorbée	(W)	930	1036	1152	1272	1394
	3 I absorbée	(A)	4.46	5.06	5.65	6.22	6.78
60	1 P frigorifique	(Watt)	799	1127	1490	1900	2368
	2 P absorbée	(W)	991	1102	1226	1361	1503
	3 I absorbée	(A)	4.51	5.23	5.95	6.65	7.33

© 2021 Tecumseh Products Company
All rights reserved

1 = cooling capacity 2 = power input 3 = current 4 = condensing temperature 5 = evaporating temperature

Nota : Tecumseh se réserve le droit de modifier les informations contenues dans ce document sans préavis.
Note : Tecumseh reserves the right to change information contained in this document without notification.