

Model: SZ300

Data

Type: Hermetic scroll compressors

Producer: Maneurop

Series: SZ

Model: SZ300

Technical data

Displacement [m ³ /h]:	76,1
:	437,5
RPM [min ⁻¹]:	2900
Weight [kg]:	157
Oil charge [dm ³]:	8
Oil type:	160SZ
Maximum system test pressure low side / high side:	25 / 32
Maximum number of starts without softstart [1/h]:	12
Refrigerant charge limit [dm ³]:	20
Refrigerant:	R407C, R134a

Connections

	<u>inches</u>
Suction Rotolock valve connection:	2 1/4"
Discharge Rotolock valve connection:	1 3/4"
Suction connection with supplied sleeve:	1 5/8"
Discharge connection with supplied sleeve:	1 1/8"

Approvals

CCC	-
CE	+
UL	+

Model: SZ300

Capacity

R134a

Cooling capacity [W]

$t_c \setminus t_e$	-15	-10	-5	0	5	10	15
30	23 221	29 286	36 550	45 170	55 302	67 104	80 733
35	21 926	27 748	34 715	42 986	52 717	64 065	77 186
40	20 606	26 167	32 823	40 728	50 041	60 917	73 514
45	19 268	24 553	30 879	38 402	47 280	57 669	69 725
50	17 919	22 912	28 892	36 017	44 443	54 328	65 827
55	-	21 251	26 869	33 579	41 537	50 901	61 827
60	-	-	24 819	31 097	38 571	47 397	57 733
65	-	-	-	28 578	35 551	43 824	53 553
70	-	-	-	-	32 486	40 188	49 293

Power input [W]

$t_c \setminus t_e$	-15	-10	-5	0	5	10	15
30	9 246	9 378	9 476	9 552	9 620	9 691	9 779
35	10 233	10 390	10 516	10 622	10 722	10 828	10 953
40	11 267	11 450	11 605	11 742	11 875	12 017	12 179
45	12 372	12 583	12 767	12 936	13 104	13 282	13 483
50	13 575	13 814	14 028	14 230	14 433	14 649	14 889
55	-	15 167	15 414	15 650	15 889	16 143	16 424
60	-	-	16 948	17 220	17 495	17 789	18 112
65	-	-	-	18 965	19 279	19 613	19 979
70	-	-	-	-	21 264	21 639	22 049

Current [A]

$t_c \setminus t_e$	-15	-10	-5	0	5	10	15
30	23.87	23.97	23.96	23.89	23.85	23.88	24.08
35	24.54	24.69	24.71	24.67	24.64	24.69	24.88
40	25.39	25.59	25.66	25.66	25.66	25.73	25.94
45	26.40	26.67	26.80	26.86	26.91	27.02	27.27
50	27.58	27.94	28.15	28.28	28.40	28.56	28.85
55	-	29.40	29.70	29.92	30.12	30.35	30.71
60	-	-	31.46	31.78	32.07	32.40	32.83
65	-	-	-	33.86	34.26	34.69	35.22
70	-	-	-	-	36.70	37.24	37.88

Model: SZ300

Capacity

Mass flow [kg/s]

$t_c \setminus t_e$	-15	-10	-5	0	5	10	15
30	537.07	664.33	812.51	984.11	1 181.66	1 407.65	1 664.62
35	532.53	659.92	808.31	980.21	1 178.14	1 404.61	1 662.14
40	527.32	654.57	802.90	974.83	1 172.88	1 399.56	1 657.39
45	521.52	648.36	796.38	968.08	1 165.98	1 392.60	1 650.46
50	515.22	641.39	788.81	960.01	1 157.51	1 383.81	1 641.43
55	-	633.72	780.30	950.73	1 147.55	1 373.26	1 630.38
60	-	-	770.91	940.31	1 136.19	1 361.04	1 617.39
65	-	-	-	928.84	1 123.50	1 347.24	1 602.55
70	-	-	-	-	1 109.58	1 331.93	1 585.94

C.O.P. [W/W]

$t_c \setminus t_e$	-15	-10	-5	0	5	10	15
30	2.51	3.12	3.86	4.73	5.75	6.92	8.26
35	2.14	2.67	3.30	4.05	4.92	5.92	7.05
40	1.83	2.29	2.83	3.47	4.21	5.07	6.04
45	1.56	1.95	2.42	2.97	3.61	4.34	5.17
50	1.32	1.66	2.06	2.53	3.08	3.71	4.42
55	-	1.40	1.74	2.15	2.61	3.15	3.76
60	-	-	1.46	1.81	2.20	2.66	3.19
65	-	-	-	1.51	1.84	2.23	2.68
70	-	-	-	-	1.53	1.86	2.24

Operating conditions: suction superheat: 10 K, subcooling: 0 K

t_c - Condensing temperature [°C]

t_e - Evaporating temperature [°C]

Application range

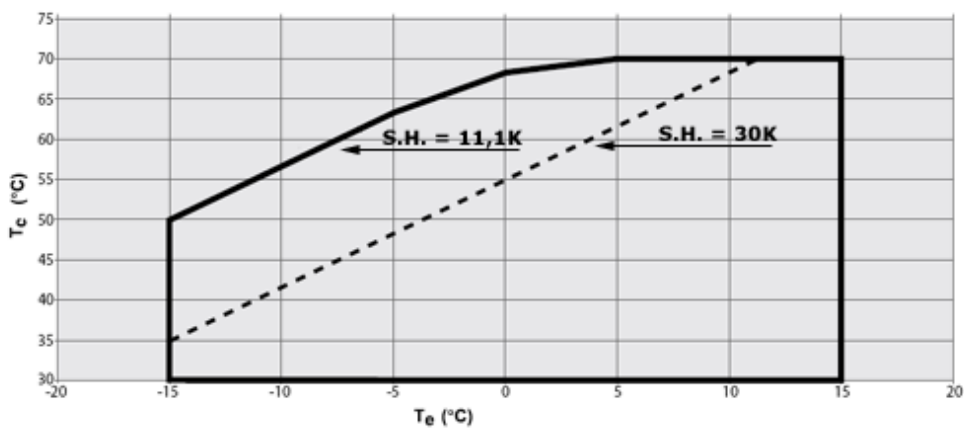

Model: SZ300

Capacity

R407C

Cooling capacity [W]

$t_c \setminus t_e$	-20	-15	-10	-5	0	5	10	15
30	29 974	37 621	46 676	57 336	69 801	84 267	100 933	119 997
35	28 636	36 132	44 973	55 359	67 487	81 555	97 761	116 304
40	27 141	34 421	42 986	53 033	64 761	78 367	94 050	112 007
45	25 528	32 530	40 755	50 400	61 665	74 746	89 842	107 150
50	23 841	30 501	38 323	47 503	58 240	70 733	85 178	101 775
55	-	28 376	35 731	44 382	54 529	66 370	80 101	95 923
60	-	-	33 021	41 081	50 574	61 699	74 653	89 636
65	-	-	-	-	46 416	56 762	68 876	82 956

Power input [W]

$t_c \setminus t_e$	-20	-15	-10	-5	0	5	10	15
30	12 224	12 358	12 495	12 642	12 803	12 986	13 197	13 442
35	13 685	13 885	14 081	14 278	14 483	14 702	14 942	15 208
40	15 233	15 501	15 757	16 008	16 259	16 517	16 789	17 079
45	16 896	17 235	17 555	17 862	18 162	18 461	18 766	19 083
50	18 706	19 118	19 504	19 869	20 220	20 564	20 905	21 251
55	-	21 179	21 633	22 059	22 464	22 854	23 235	23 612
60	-	-	23 972	24 462	24 924	25 362	25 784	26 196
65	-	-	-	-	27 628	28 118	28 584	29 032

Current [A]

$t_c \setminus t_e$	-20	-15	-10	-5	0	5	10	15
30	24.79	25.11	25.32	25.46	25.57	25.68	25.84	26.09
35	26.98	27.37	27.64	27.85	28.03	28.22	28.46	28.78
40	29.04	29.49	29.83	30.10	30.35	30.62	30.93	31.33
45	31.12	31.62	32.03	32.37	32.69	33.02	33.41	33.89
50	33.37	33.93	34.39	34.80	35.18	35.58	36.04	36.60
55	-	36.55	37.07	37.54	37.99	38.46	38.99	39.62
60	-	-	40.23	40.75	41.26	41.80	42.40	43.10
65	-	-	-	-	45.16	45.76	46.42	47.19

Model: SZ300

Capacity

Mass flow [kg/s]

$t_c \setminus t_e$	-20	-15	-10	-5	0	5	10	15
30	584.69	723.71	884.67	1 070.62	1 284.60	1 529.66	1 808.84	2 125.19
35	583.33	724.55	887.83	1 076.21	1 292.75	1 540.48	1 822.45	2 141.71
40	579.51	722.01	886.69	1 076.59	1 294.76	1 544.24	1 828.08	2 149.33
45	573.37	716.23	881.39	1 071.89	1 290.78	1 541.10	1 825.90	2 148.22
50	565.06	707.37	872.09	1 062.28	1 280.97	1 531.21	1 816.05	2 138.53
55	-	695.58	858.95	1 047.90	1 265.47	1 514.71	1 798.68	2 120.40
60	-	-	842.10	1 028.90	1 244.44	1 491.77	1 773.94	2 093.98
65	-	-	-	-	1 218.03	1 462.53	1 741.99	2 059.44

C.O.P. [W/W]

$t_c \setminus t_e$	-20	-15	-10	-5	0	5	10	15
30	2.45	3.04	3.74	4.54	5.45	6.49	7.65	8.93
35	2.09	2.60	3.19	3.88	4.66	5.55	6.54	7.65
40	1.78	2.22	2.73	3.31	3.98	4.74	5.60	6.56
45	1.51	1.89	2.32	2.82	3.40	4.05	4.79	5.61
50	1.27	1.60	1.96	2.39	2.88	3.44	4.07	4.79
55	-	1.34	1.65	2.01	2.43	2.90	3.45	4.06
60	-	-	1.38	1.68	2.03	2.43	2.90	3.42
65	-	-	-	-	1.68	2.02	2.41	2.86

Operating conditions: suction superheat: 11.1 K, subcooling: 8.3 K

t_c - Condensing temperature [°C]

t_e - Evaporating temperature [°C]

Application range

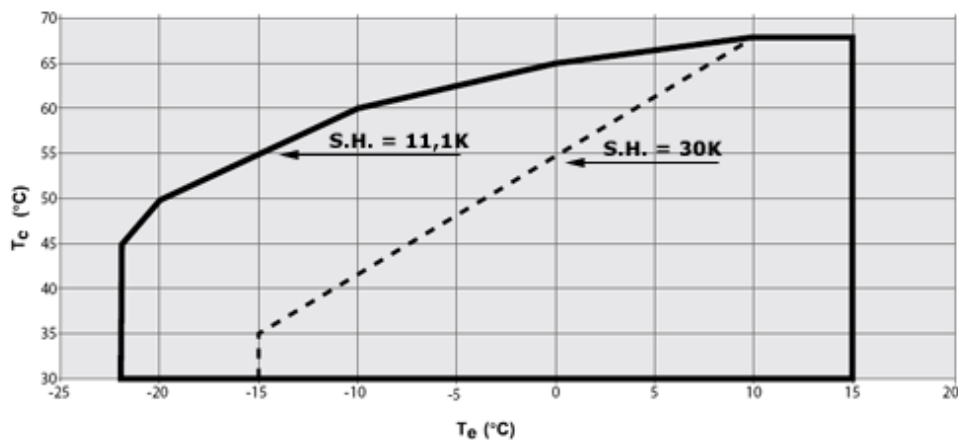

Model: SZ300

Electrical

Electrical data

Starting current [A]:	270
Maximum Continuous Current (MCC) [A]:	69
Winding resistance (between phases) [Ω]:	0,516

Connection diagram for systems with refrigerant suction

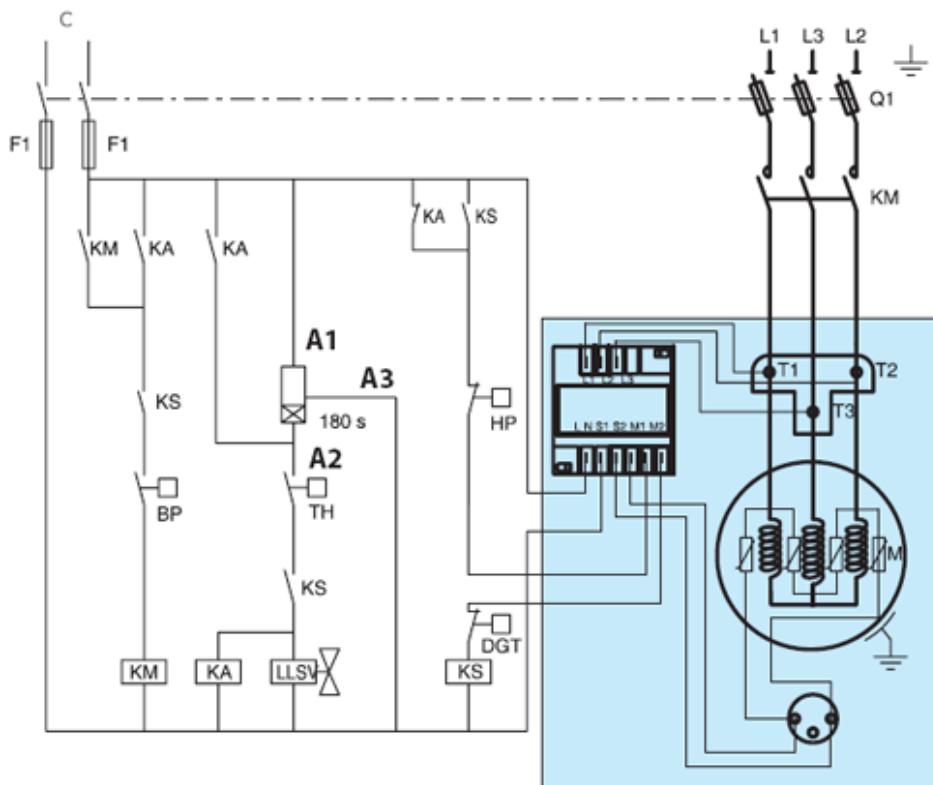

- TH: Thermostat
- 180 s: ATI electronic timer
- KA: Control transmitter CI 4-2
- LLSV: Electromagnetic liquid valve
- KM: Main contactor CI
- KS: Fuses' switch
- BP: Low pressure switch
- HP: High pressure switch
- Q1: Safety switch
- F1: Fuses / S: Thermal relay TI
- F2: Thermal relay TI
- M: Compressor's engine
- DGT: Discharge gas thermostat

Model: SZ300

Electrical

Connection diagram for systems without refrigerant suction

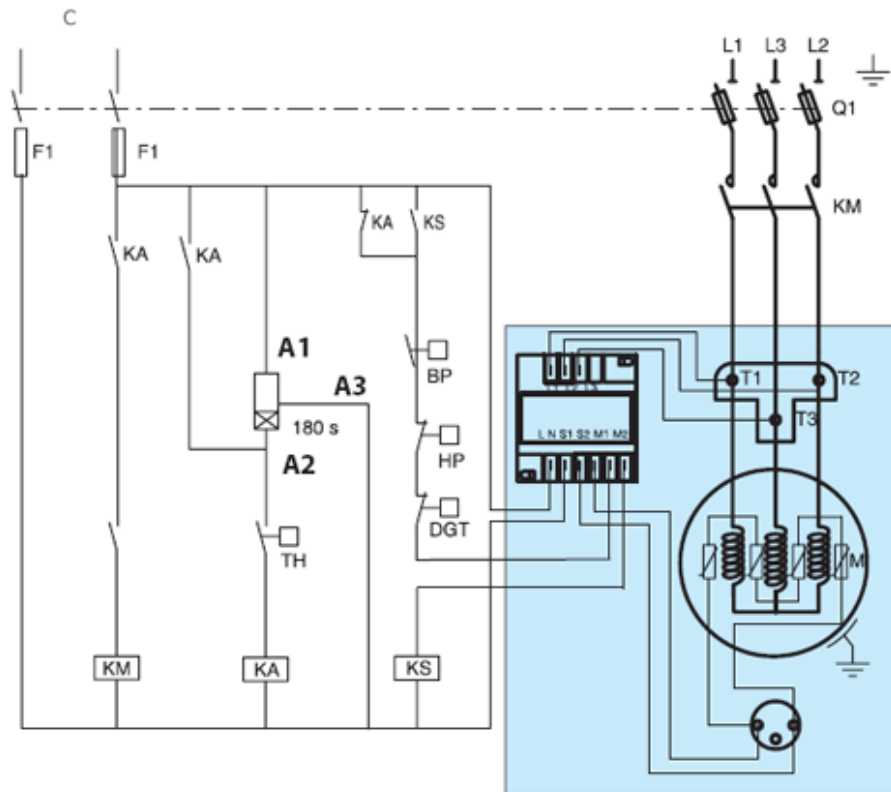

- TH: Thermostat
- 180 s: ATI electronic timer
- KA: Control transmitter CI 4-2
- LLSV: Electromagnetic liquid valve
- KM: Main contactor CI
- KS: Fuses' switch
- BP: Low pressure switch
- HP: High pressure switch
- Q1: Safety switch
- F1: Fuses / S: Thermal relay TI
- F2: Thermal relay TI
- M: Compressor's engine
- DGT: Discharge gas thermostat

Model: SZ300

Equipment

Equipment

- ▶ oil equalization - thread adapter 1/2"
 - ▶ belt type heater - crankcase heater 130W, 230V
 - ▶ soft-start kit - electronic softstart MCI 50C
 - ▶ acoustic hood - acoustic shield of Danfoss catalogue number 7755016
 - ▶ discharge thermostatic protection - discharge temperature protection accessory - Danfoss catalogue number 7750009
-