



Compressor
Voltage Code : TZ

TAJ4519T-TZ

High Temp. Commercial (HP)

400V 3~ 50Hz / 440V 3~ 60 Hz

R22

AJ4519T-TZ1C

Conditions	Frequency	Nominal Cooling Capacity		Sound Power ISO3745 / ISO 3743-1
		Watts	BTU/h	
EN12900 / R22	50 Hz / 60 Hz	4453 / 5264	15186 / 17950	70 dBA

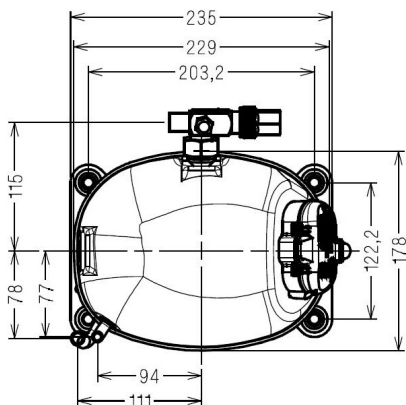
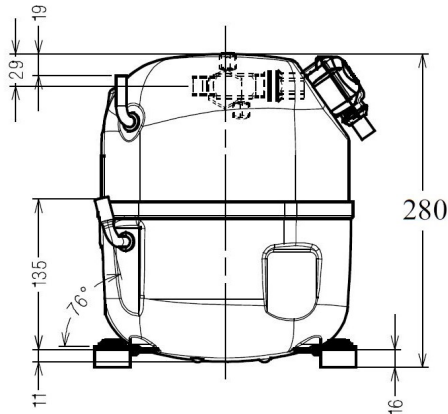

Displacement (cc)	34.5
Net Weight (Kg)	20.2
Oil Quantity (cc)	475.0
Oil Type	Mineral
Expansion Device	Capillary_Tube/Expansion_Valve
Cooling	Fan
Main Winding (Ohm)	8.7
Current	
RLA (A)	3.5 3.6
MCC (A)	4.2 4.2
LRA (A)	22 23
Electrical Equipment	TRI
Overload	Interne
Refrigerating connection for OD	
Suction Tube	15.9 (5/8")
Discharge Tube	9.5 (3/8")
Process Tube	6.35 (1/4")

* EN12900 : T°Cond. 50.0°C / T°Evap. 5.0°C / T°Return gas temp.. 20.0°C
T°Subcooling. 0.0K

Certificates :



Note : Tecumseh reserves the right to change information contained in this document without notification.



Tecumseh

TAJ4519T-TZ	Tension TZ : 400V 3~ 50Hz / 440V 3~ 60 Hz
--------------------	--

Les performances sont données dans les conditions EN12900 :	Gaz aspirés :	20.0 °C
Condition Dew	Sous refroidissement :	0.0 K
The performance data are in EN12900 conditions :	Return gas :	20.0 °C
Dew Condition	Subcooling :	0.0 K

50 Hz R22

N°234SU-TZ

4 T condensation	5 T évaporation	(°C)	-20	-15	-10	-5	0	5	10	15
40	1 P frigorifique	(Watt)	1971	2462	3039	3700	4441	5260	6155	7121
	2 P absorbée	(W)	1240	1303	1370	1440	1514	1590	1671	1754
	3 I absorbée	(A)	2.47	2.54	2.61	2.69	2.78	2.87	2.97	3.08
50	1 P frigorifique	(Watt)	1535	1975	2489	3076	3731	4453	5238	6083
	2 P absorbée	(W)	1174	1291	1407	1522	1635	1748	1858	1968
	3 I absorbée	(A)	2.34	2.48	2.63	2.78	2.94	3.10	3.26	3.43
60	1 P frigorifique	(Watt)		1462	1922	2443	3022	3655	4339	5071
	2 P absorbée	(W)		1278	1444	1604	1758	1906	2048	2184
	3 I absorbée	(A)		2.44	2.66	2.88	3.10	3.33	3.55	3.77

60 Hz R22

N°234SU-TZ

4 T condensation	5 T évaporation	(°C)	-20	-15	-10	-5	0	5	10	15
40	1 P frigorifique	(Watt)	2513	3024	3653	4398	5254	6218	7285	8453
	2 P absorbée	(W)	1369	1513	1653	1788	1919	2045	2165	2281
	3 I absorbée	(A)	2.29	2.48	2.66	2.83	3.00	3.17	3.33	3.48
50	1 P frigorifique	(Watt)	1961	2425	2991	3655	4414	5264	6200	7219
	2 P absorbée	(W)	1289	1499	1699	1890	2073	2245	2409	2563
	3 I absorbée	(A)	2.16	2.42	2.68	2.93	3.17	3.41	3.65	3.88
60	1 P frigorifique	(Watt)		1796	2309	2904	3575	4321	5135	6014
	2 P absorbée	(W)		1482	1744	1993	2227	2448	2655	2849
	3 I absorbée	(A)		2.37	2.70	3.03	3.35	3.66	3.97	4.28

1 = cooling capacity 2 = power input 3 = current 4 = condensing temperature 5 = evaporating temperature

Nota : Tecumseh se réserve le droit de modifier les informations contenues dans ce document sans préavis.

Note : Tecumseh reserves the right to change information contained in this document without notification.

© 2020 Tecumseh Products Company
All rights reserved