

# Model: D9RS-1500

## Data

---

Type: Semi-hermetic piston compressors

Producer: Copeland

Series: S

## Model: D9RS-1500

### Technical data

Cylinder count:	3
Displacement [m <sup>3</sup> /h]:	49,9
Weight [kg]:	176
Oil charge [dm <sup>3</sup> ]:	2,9
Max. operating current [A]:	31,4
Locked rotor current [A]:	129
Power supply [V/~/Hz]:	400V/3/50Hz

### Connections

	<u>milimeters</u>	<u>inches</u>
Suction line:		
Discharge line:		

# Model: D9RS-1500

## Capacity

R407C

### Cooling capacity [kW]

$t_c \setminus t_e$	-25	-20	-15	-10	-5	0	5	10
30	12.57	16.71	21.51	27.06	33.47	40.81	49.19	58.69
35	11.28	15.29	19.93	25.28	31.45	38.52	46.59	55.74
40	10.00	13.87	18.34	23.48	29.41	36.20	43.94	52.74
45	-	12.46	16.75	21.68	27.35	33.85	41.28	49.71
50	-	-	15.17	19.88	25.29	31.50	38.59	46.66
55	-	-	13.60	18.08	23.23	29.13	35.89	43.58
60	-	-	-	16.31	21.18	26.78	33.18	40.49

### Power input [kW]

$t_c \setminus t_e$	-25	-20	-15	-10	-5	0	5	10
30	5.82	6.56	7.25	7.87	8.38	8.77	9.01	9.08
35	6.02	6.86	7.66	8.40	9.05	9.59	10.00	10.25
40	6.18	7.11	8.02	8.89	9.68	10.38	10.95	11.38
45	-	7.33	8.35	9.34	10.27	11.11	11.85	12.46
50	-	-	8.63	9.74	10.81	11.80	12.71	13.49
55	-	-	8.88	10.11	11.31	12.45	13.52	14.48
60	-	-	-	10.44	11.76	13.05	14.28	15.41

# Model: D9RS-1500

## Capacity

---

### Current [A]

<b>t<sub>c</sub> \ t<sub>e</sub></b>	<b>-25</b>	<b>-20</b>	<b>-15</b>	<b>-10</b>	<b>-5</b>	<b>0</b>	<b>5</b>	<b>10</b>
<b>30</b>	13.30	14.26	15.20	16.06	16.81	17.38	17.73	17.82
<b>35</b>	13.55	14.65	15.76	16.82	17.79	18.61	19.24	19.63
<b>40</b>	13.76	15.01	16.28	17.54	18.73	19.81	20.72	21.41
<b>45</b>	-	15.31	16.76	18.22	19.64	20.97	22.16	23.17
<b>50</b>	-	-	17.18	18.84	20.49	22.08	23.56	24.88
<b>55</b>	-	-	17.54	19.41	21.30	23.15	24.91	26.55
<b>60</b>	-	-	-	19.91	22.03	24.15	26.21	28.16

### Mass flow [kg/s]

<b>t<sub>c</sub> \ t<sub>e</sub></b>	<b>-25</b>	<b>-20</b>	<b>-15</b>	<b>-10</b>	<b>-5</b>	<b>0</b>	<b>5</b>	<b>10</b>
<b>30</b>	273.16	358.88	456.17	566.66	691.95	833.68	993.48	1 172.95
<b>35</b>	255.49	341.57	439.08	549.66	674.92	816.49	975.99	1 155.05
<b>40</b>	236.65	323.03	420.73	531.37	656.56	797.94	957.12	1 135.72
<b>45</b>	-	303.35	401.21	511.87	636.96	778.10	936.93	1 115.05
<b>50</b>	-	-	380.58	491.23	616.18	757.06	915.49	1 093.09
<b>55</b>	-	-	358.93	469.53	594.31	734.89	892.89	1 069.93
<b>60</b>	-	-	-	446.85	571.42	711.66	869.19	1 045.64

# Model: D9RS-1500

Capacity

## C.O.P. [W/W]

$t_c \setminus t_e$	-25	-20	-15	-10	-5	0	5	10
30	2.16	2.55	2.97	3.44	3.99	4.66	5.46	6.47
35	1.88	2.23	2.60	3.01	3.47	4.01	4.66	5.44
40	1.62	1.95	2.29	2.64	3.04	3.49	4.01	4.63
45	-	1.70	2.01	2.32	2.66	3.05	3.48	3.99
50	-	-	1.76	2.04	2.34	2.67	3.04	3.46
55	-	-	1.53	1.79	2.05	2.34	2.66	3.01
60	-	-	-	1.56	1.80	2.05	2.32	2.63

## Application range

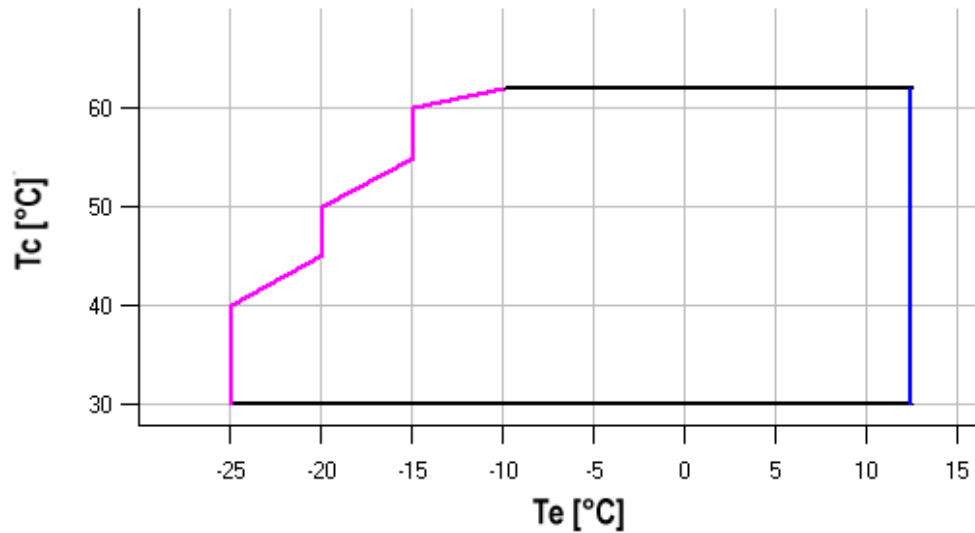

Maximum evaporating temperature

Operating conditions: ISO; subcooling: 0 K, suction superheat: 10 K, return gas temperature: -

$t_c$  - Condensing temperature [°C]

$t_e$  - Evaporating temperature [°C]

# Model: D9RS-1500

## Dimensions

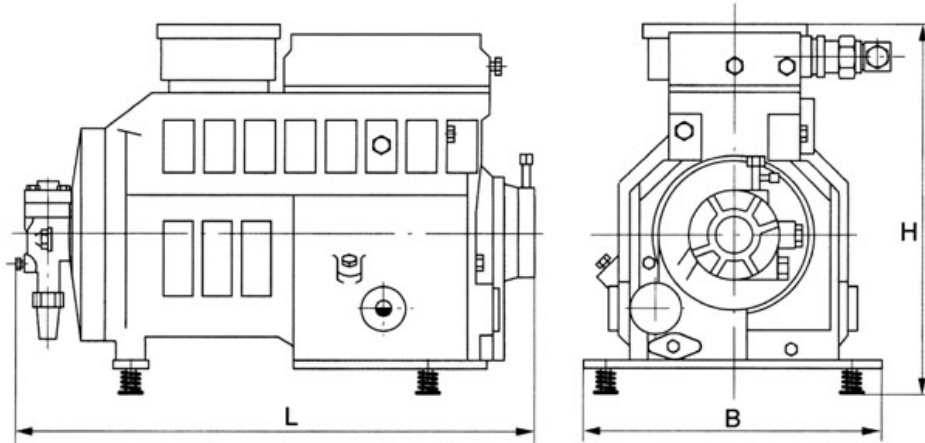

L	730 mm
B	355 mm
H	480 mm

# Model: D9RS-1500

Image

---

