



Installation Operation Maintenance

**Cooling only: CGAN 200 - 250 - 300 -
400 - 450 - 490 - 500 - 600 - 700 - 800 -
900 - 925**

**Reversible: CXAN 200 - 250 - 300 - 400
- 450 - 490 - 500 - 600 - 700 - 800 - 900
- 925**

AquaStream²®



CG-SVX01C-E4



General information

Foreword

These instructions are given as a guide to good practice in the installation, start-up, operation, and maintenance by the user, of Trane CGAN/CXAN 200-925 chillers. They do not contain full service procedures necessary for the continued successful operation of this equipment. The services of a qualified technician should be employed through the medium of a maintenance contract with a reputable service company. Read this manual thoroughly before unit start-up.

Units are assembled, pressure tested, dehydrated, charged and run tested before shipment.

Warnings and cautions

Warnings and Cautions appear at appropriate sections throughout this manual. Your personal safety and the proper operation of this machine require that you follow them carefully. The constructor assumes no liability for installations or servicing performed by unqualified personnel.

WARNING! : Indicates a potentially hazardous situation which, if not avoided, could result in death or serious injury.

CAUTION! : Indicates a potentially hazardous situation which, if not avoided, may result in minor or moderate injury. It may also be used to alert against unsafe practices or for equipment or property-damage-only accidents.

Safety recommendations

To avoid death, injury, equipment or property damage, the following recommendations should be observed during maintenance and service visits:

1. The maximum allowable pressures for system leak testing on low and high pressure side are given in the chapter "Installation". Always provide a pressure regulator.
2. Disconnect the main power supply before any servicing on the unit.
3. Service work on the refrigeration system and the electrical system should be carried out only by qualified and experienced personnel.

General information

Reception

On arrival, inspect the unit before signing the delivery note.

Reception in France only:

In case of visible damage: The consignee (or the site representative) must specify any damage on the delivery note, legibly sign and date the delivery note, and the truck driver must countersign it.

The consignee (or the site representative) must notify Trane Epinal Operations - Claims team and send a copy of the delivery note.

The customer (or the site representative) should send a registered letter to the last carrier within 3 days of delivery.

Note: for deliveries in France, even concealed damage must be looked for at delivery and immediately treated as visible damage.

Reception in all countries except France:

In case of concealed damage: The consignee (or the site representative) must send a registered letter to the last carrier within 7 days of delivery, claiming for the described damage. A copy of this letter must be sent to Trane Epinal Operations - Claims team.

Warranty

Warranty is based on the general terms and conditions of the manufacturer. The warranty is void if the equipment is repaired or modified without the written approval of the manufacturer, if the operating limits are exceeded or if the control system or the electrical wiring is modified. Damage due to misuse, lack of maintenance or failure to comply with the manufacturer's instructions or recommendations is not covered by the warranty obligation. If the user does not conform to the rules of this manual, it may entail cancellation of warranty and liabilities by the manufacturer.

Refrigerant

The refrigerant provided by the manufacturer meets all the requirements of our units. When using recycled or reprocessed refrigerant, it is advisable to ensure its quality is equivalent to that of a new refrigerant. For this, it is necessary to have a precise analysis made by a specialized laboratory. If this condition is not respected, the manufacturer warranty could be cancelled.

General information

Maintenance contract

It is strongly recommended that you sign a maintenance contract with your local Service Agency. This contract provides regular maintenance of your installation by a specialist in our equipment. Regular maintenance ensures that any malfunction is detected and corrected in good time and minimizes the possibility that serious damage will occur. Finally, regular maintenance ensures the maximum operating life of your equipment. We would remind you that failure to respect these installation and maintenance instructions may result in immediate cancellation of the warranty.

Training

To assist you in obtaining the best use of it and maintaining it in perfect operating condition over a long period of time, the manufacturer has at your disposal a refrigeration and air conditioning service school. The principal aim of this is to give operators and technicians a better knowledge of the equipment they are using, or that is under their charge. Emphasis is particularly given to the importance of periodic checks on the unit operating parameters as well as on preventive maintenance, which reduces the cost of owning the unit by avoiding serious and costly breakdown.

Contents

General information	2
Installation	
General data	6
General unit characteristics	15
Unit nameplate	15
Installation instructions	15
Handling	15
Minimal installation water content	18
Water treatment	20
Antifreeze protection	20
Electrical connections	20
General start-up	
Preparation	22
Start-up	22
Operation	
Control and unit operation	27
Weekly start up and week-end shutdown	27
Start-up and seasonal shutdown	27
Maintenance	
Maintenance instructions	28
Installation checklist	29
Troubleshooting guide	30



General Data

Table 1 - CGAN Cooling only - Standard version - R407C

		CGAN 200	CGAN 250	CGAN 300	CGAN 400	CGAN 450	CGAN 490
Eurovent Performances (1)							
Net Cooling Capacity	(kW)	50.7	62.5	76.2	102.8	121.8	132.3
Total Power input in cooling	(kW)	19.1	24.4	28.8	38.7	43.6	50.5
Water pressure drop	(kPa)	29	33	38	46	43	44
Pressure available (5)	(kPa)	195	180	173	139	195	181
Main Power supply		400/3/50	400/3/50	400/3/50	400/3/50	400/3/50	400/3/50
Units Amps							
Nominal (4)	(A)	47	57	69	89	102	111
Start-up Amps	(A)	148	203	215	236	327	336
Short circuit unit capacity	(kA)	10	10	10	10	10	10
Max supply cable size	(mm ²)	16	35	35	95	95	95
Min supply cable size	(mm ²)	10	16	16	50	50	50
Compressor							
Number		2	2	2	3	2	2
Type		Scroll	Scroll	Scroll	Scroll	Scroll	Scroll
Model		(10T+10T)	(10T+15T)	(15T+15T)	(15T+15T+10T)	(20T+25T)	(25T+25T)
Rated Amps (4)	(A)	19+19	19+28.5	28.5+28.5	28.5+28.5+19	38+47	47+47
Locked rotor Amps (2)	(A)	120	175	175	175	272	272
Motor RPM	(rpm)	2900	2900	2900	2900	2900	2900
Power factor		0.84	0.85	0.85	0.85	0.87	0.87
Sump Heater (2)	(W)	100	160	160	160	150	150
Evaporator							
Number		1	1	1	1	1	1
Type		Brazed plate	Brazed plate	Brazed plate	Brazed plate	Brazed plate	Brazed plate
Model		V200x38	V200x46	V200x54	V200x72	AC 120-108 EQ	AC 120-120 EQ
Water volume (total)	(l)	5.3	6.8	8.2	10.5	11.3	12.6
Antifreeze Heater	(W)	115	115	115	115	115	115
Unit Water Connections		Male ISO R7	Male ISO R7	Male ISO R7	Male ISO R7	Male ISO R7	Male ISO R7
Water Connections Diameter		2"	2"	2 1/2"	2 1/2"	2 1/2"	2 1/2"
Coil							
Type		Slit Fin	Slit Fin	Slit Fin	Slit Fin	Slit Fin	Slit Fin
Length	(mm)	2489	2489	2896	2896	2896	2896
Height	(mm)	1422	1422	1422	1626	1626	1626
Face Area (3)	(m ²)	3.54	3.54	4.12	4.71	4.71	4.71
Rows		2	3	3	3	4	4
Fins per foot	(fpf)	204	180	180	180	168	168
Fan							
Type		Propeller	Propeller	Propeller	Propeller	Propeller	Propeller
Number		2	2	3	3	3	3
Diameter	(mm)	710	710	710	800	800	800
Drive type		Direct drive	Direct drive	Direct drive	Direct drive	Direct drive	Direct drive
Air flow	(m ³ /h)	20200	19100	26300	37300	37100	37100
Number of motors		2	2	3	3	3	3
Motor HP (2)	(kW)	0.57	0.57	0.57	1.05	1.05	1.05
Rated Amps (2)	(A)	1.5	1.5	1.5	2.4	2.4	2.4
Motor RPM	(rpm)	700	700	700	680	680	680
Dimensions							
Height (6)	(mm)	1897	1897	1897	2074	2074	2074
Length	(mm)	2800	2800	3200	3200	3200	3200
Width	(mm)	1100	1100	1100	1100	1100	1100
Operating Weight	(kg)	748	842	968	1143	1267	1292
Shipping Weight	(kg)	743	834	954	1124	1260	1284
System Data							
Number of refrigerant circuits		1	1	1	1	1	1
Capacity steps		2	2	2	2	2	2
Minimum capacity	(%)	50	40/60	50	37/63	37/63	37/63
Refrigerant Charge (3)							
Circuit A	(kg)	13	18	21	24	28	28
Circuit B	(kg)	-	-	-	-	-	-

- (1) at Eurovent Conditions (Evap 12°C/7°C - Air. 35°C)
- (2) per motor
- (3) per circuit
- (4) Max rated conditions.
- (5) Dual Pump Option
- (6) For units with HESP option, contact your local sales office

General Data

Table 1 - cont

		CGAN 500	CGAN 600	CGAN 700	CGAN 800	CGAN 900	CGAN 925
Eurovent Performances (1)							
Net Cooling Capacity	(kW)	128.9	157.1	182.8	214.2	241.3	267.0
Total Power input in cooling	(kW)	49.1	57.9	68.4	77.9	88.3	102.4
Water pressure drop	(kPa)	30	36	30	35	35	41
Pressure available (5)	(kPa)	206	185	196	174	137	124
Main Power supply		400/3/50	400/3/50	400/3/50	400/3/50	400/3/50	400/3/50
Units Amps							
Nominal (4)	(A)	113	136	153	188	208	225
Start-up Amps	(A)	259	282	300	334	354	450
Short circuit unit capacity	(kA)	10	10	10	10	10	10
Max supply cable size	(mm ²)	95	95	150	150	150	150
Min supply cable size	(mm ²)	50	50	95	95	95	95
Compressor							
Number		4	4	6	6	6	4
Type		Scroll	Scroll	Scroll	Scroll	Scroll	Scroll
Model		(10T+15T)	(15T+15T)	(10T+10T+15T)	(15T+15T+10T)	(15T+15T+15T)	(25T+25T)
Rated Amps (4)	(A)	2x(19+28.5)	2x(28.5+28.5)	2x(19+19+28.5)	2x(28.5+28.5+19)	2x(28.5+28.5+28.5)	2x(47+47)
Locked rotor Amps (2)	(A)	175	175	175	175	175	272
Motor RPM	(rpm)	2900	2900	2900	2900	2900	2900
Power factor		0.85	0.85	0.85	0.85	0.85	0.87
Sump Heater (2)	(W)	160	160	160	160	160	150
Evaporator							
Number		1	1	1	1	1	1
Type		Brazed plate	Brazed plate	Brazed plate	Brazed plate	Brazed plate	Brazed plate
Model		DV58-82	DV58-94	DV58x122	DV58x138	DV58x170	DV58x170
Water volume (total)	(l)	17.2	19.8	25.6	29.0	35.7	35.7
Antifreeze Heater	(W)	180	180	180	180	180	180
Unit Water Connections		Male ISO R7	Male ISO R7	Male ISO R7	Male ISO R7	Male ISO R7	Male ISO R7
Water Connections Diameter		2 1/2"	2 1/2"	3"	3"	3"	3"
Coil							
Type		Slit Fin	Slit Fin	Slit Fin	Slit Fin	Slit Fin	Slit Fin
Length	(mm)	2489	2896	2896	2896	2896	2896
Height	(mm)	1422	1422	1626	1626	1626	1626
Face Area (3)	(m ²)	3.54	4.12	4.71	4.71	4.71	4.71
Rows		3	3	3	3	4	4
Fins per foot	(fpf)	180	180	180	180	180	168
Fan							
Type		Propeller	Propeller	Propeller	Propeller	Propeller	Propeller
Number		4	6	6	6	6	6
Diameter	(mm)	710	710	710	800	800	800
Drive type		Direct drive	Direct drive	Direct drive	Direct drive	Direct drive	Direct drive
Air flow	(m ³ /h)	38300	52700	55400	86300	83000	79300
Number of motors		4	6	6	6	6	6
Motor HP (2)	(kW)	0.57	0.57	0.57	1.4	1.4	1.4
Rated Amps (2)	(A)	1.5	1.5	1.5	4	4	4
Motor RPM	(rpm)	700	700	700	680	680	680
Dimensions							
Height (6)	(mm)	1897	1897	2100	2100	2100	2100
Length	(mm)	3400	3400	3400	3400	3400	3400
Width	(mm)	2300	2300	2300	2300	2300	2300
Operating Weight	(kg)	1623	1818	2087	2245	2423	2456
Shipping Weight	(kg)	1588	1778	2030	2181	2344	2377
System Data							
Number of refrigerant circuits		2	2	2	2	2	2
Capacity steps		4	4	4	4	4	4
Minimum capacity	(%)	20/30	25	22/29	19/32	17/33	17/33
Refrigerant Charge (3)							
Circuit A	(kg)	19	22	27	27	34	31
Circuit B	(kg)	19	22	27	27	34	31

- (1) at Eurovent Conditions (Evap 12°C/7°C - Air. 35°C)
- (2) per motor
- (3) per circuit
- (4) Max rated conditions.
- (5) Dual Pump Option
- (6) For units with HESP option, contact your local sales office



General Data

Table 2 - CGAN cooling only - Super Quiet version - R407C

		CGAN 200	CGAN 250	CGAN 300	CGAN 400	CGAN 450	CGAN 490
Eurovent Performances (1)							
Net Cooling Capacity	(kW)	50.5	62.2	75.7	101.9	121.8	132.3
Total Power input in cooling	(kW)	18.8	24.2	28.4	36.4	43.6	50.5
Water pressure drop	(kPa)	29	32	37	45	43	44
Pressure available (5)	(kPa)	195	180	174	141	195	181
Main Power supply		400/3/50	400/3/50	400/3/50	400/3/50	400/3/50	400/3/50
Units Amps							
Nominal (4)	(A)	46	55	66	90	102	111
Start-up Amps	(A)	147	202	213	236	327	336
Short circuit unit capacity	(kA)	10	10	10	10	10	10
Max supply cable size	(mm ²)	16	35	35	95	95	95
Min supply cable size	(mm ²)	10	16	16	50	50	50
Compressor							
Number		2	2	2	3	2	2
Type		Scroll	Scroll	Scroll	Scroll	Scroll	Scroll
Model		(10T+10T)	(10T+15T)	(15T+15T)	(15T+15T+10T)	(20T+25T)	(25T+25T)
Rated Amps (2)(4)	(A)	19+19	19+28.5	28.5+28.5	28.5+28.5+19	38+47	47+47
Locked rotor Amps (2)	(A)	120	175	175	175	272	272
Motor RPM	(rpm)	2900	2900	2900	2900	2900	2900
Power factor		0.84	0.85	0.85	0.85	0.87	0.87
Sump Heater (2)	(W)	100	160	160	160	150	150
Evaporator							
Number		1	1	1	1	1	1
Type		Brazed plate	Brazed plate	Brazed plate	Brazed plate	Brazed plate	Brazed plate
Water volume (total)	(l)	5.3	6.8	8.2	10.5	11.3	12.6
Antifreeze Heater	(W)	115	115	115	115	115	115
Unit Water Connections		Male ISO R7	Male ISO R7	Male ISO R7	Male ISO R7	Male ISO R7	Male ISO R7
Water Connections Diameter		2"	2"	2 1/2"	2 1/2"	2 1/2"	2 1/2"
Coil							
Type		Slit Fin	Slit Fin	Slit Fin	Slit Fin	Slit Fin	Slit Fin
Length	(mm)	2489	2489	2896	2896	2896	2896
Height	(mm)	1422	1422	1422	1626	1626	1626
Face Area (3)	(m ²)	3.54	3.54	4.12	4.71	4.71	4.71
Rows		2	3	3	3	4	4
Fins per foot	(fpf)	204	180	180	180	168	168
Fan							
Type		Propeller	Propeller	Propeller	Propeller	Propeller	Propeller
Number		2	2	3	3	3	3
Diameter	(mm)	710	710	710	800	800	800
Drive type		Direct drive	Direct drive	Direct drive	Direct drive	Direct drive	Direct drive
Air flow	(m ³ /h)	20200	19100	26300	37300	37100	37100
Motors Number		2	2	3	3	3	3
Motor HP (2)	(kW)	0.57	0.57	0.57	1.05	1.05	1.05
Rated Amps (2)	(A)	1.5	1.5	1.5	2.4	2.4	2.4
Motor RPM	(rpm)	700	700	700	680	680	680
Dimensions							
Height (6)	(mm)	1897	1897	1897	2048	2048	2048
Length	(mm)	2800	2800	3200	3200	3200	3200
Width	(mm)	1100	1100	1100	1100	1100	1100
Operating Weight	(kg)	778	872	1010	1155	1279	1304
Shipping Weight	(kg)	773	864	996	1136	1272	1296
System Data							
Refrigerant circuit		1	1	1	1	1	1
Capacity steps		2	2	2	2	2	2
Minimum capacity	(%)	50	40/60	50	37/63	37/63	37/63
Refrigerant Charge (3)							
Circuit A	(kg)	13	18	21	24	28	28
Circuit B	(kg)	-	-	-	-	-	-

- (1) at Eurovent Conditions (Evap 12°C/7°C - Air. 35°C)
- (2) per motor
- (3) per circuit
- (4) Max rated conditions.
- (5) Dual Pump Option
- (6) For units with HESP option, contact your local sales office

General Data

Table 2 cont

		CGAN 500	CGAN 600	CGAN 700	CGAN 800	CGAN 900	CGAN 925
Eurovent Performances (1)							
Net Cooling Capacity	(kW)	128.1	156.1	181.5	212.1	238.0	264.9
Total Power input in cooling	(kW)	48.8	57.2	68.0	73.4	85.0	102.1
Water pressure drop	(kPa)	29	36	29	34	34	40
Pressure available (5)	(kPa)	207	186	197	176	139	126
Main Power supply		400/3/50	400/3/50	400/3/50	400/3/50	400/3/50	400/3/50
Units Amps							
Nominal (4)	(A)	110	131	150	178	200	216
Start-up Amps	(A)	256	278	295	324	344	441
Short circuit unit capacity	(kA)	10	10	10	10	10	10
Max supply cable size	(mm ²)	95	95	150	150	150	150
Min supply cable size	(mm ²)	50	50	95	95	95	95
Compressor							
Number		4	4	6	6	6	4
Type		Scroll	Scroll	Scroll	Scroll	Scroll	Scroll
Model		(10T+15T)	(15T+15T)	(10T+10T+15T)	(15T+15T+10T)	(15T+15T+15T)	(25T+25T)
Rated Amps (2)(4)	(A)	2x(19+28.5)	2x(28.5+28.5)	2x(19+19+28.5)	2x(28.5+28.5+19)	2x(28.5+28.5+28.5)	2x(47+47)
Locked rotor Amps (2)	(A)	175	175	175	175	175	272
Motor RPM	(rpm)	2900	2900	2900	2900	2900	2900
Power factor		0.85	0.85	0.85	0.85	0.85	0.87
Sump Heater (2)	(W)	160	160	160	160	160	150
Evaporator							
Number		1	1	1	1	1	1
Type		Brazed plate	Brazed plate	Brazed plate	Brazed plate	Brazed plate	Brazed plate
Water volume (total)	(l)	17.2	19.8	25.6	29.0	35.7	35.7
Antifreeze Heater	(W)	180	180	180	180	180	180
Unit Water Connections		Male ISO R7	Male ISO R7	Male ISO R7	Male ISO R7	Male ISO R7	Male ISO R7
Water Connections Diameter		2 1/2"	2 1/2"	3"	3"	3"	3"
Coil							
Type		Slit Fin	Slit Fin	Slit Fin	Slit Fin	Slit Fin	Slit Fin
Length	(mm)	2489	2896	2896	2896	2896	2896
Height	(mm)	1422	1422	1626	1626	1626	1626
Face Area (3)	(m ²)	3.54	4.12	4.71	4.71	4.71	4.71
Rows		3	3	3	3	4	4
Fins per foot	(fpf)	180	180	180	180	180	168
Fan							
Type		Propeller	Propeller	Propeller	Propeller	Propeller	Propeller
Number		4	6	6	6	6	6
Diameter	(mm)	710	710	710	800	800	800
Drive type		Direct drive	Direct drive	Direct drive	Direct drive	Direct drive	Direct drive
Air flow	(m ³ /h)	38300	52700	55400	74700	71400	74300
Motors Number		4	6	6	6	6	6
Motor HP (2)	(kW)	0.57	0.57	0.57	1.05	1.05	1.05
Rated Amps (2)	(A)	1.5	1.5	1.5	2.4	2.4	2.4
Motor RPM	(rpm)	700	700	700	680	680	680
Dimensions							
Height (6)	(mm)	1897	1897	2100	2074	2074	2074
Length	(mm)	3400	3400	3400	3400	3400	3400
Width	(mm)	2300	2300	2300	2300	2300	2300
Operating Weight	(kg)	1685	1900	2171	2335	2513	2546
Shipping Weight	(kg)	1650	1860	2114	2271	2434	2467
System Data							
Refrigerant circuit		2	2	2	2	2	2
Capacity steps		4	4	4	4	4	4
Minimum capacity	(%)	20/30	25	22/29	19/32	17/33	17/33
Refrigerant Charge (3)							
Circuit A	(kg)	19	22	27	27	34	31
Circuit B	(kg)	19	22	27	27	34	31

(1) at Eurovent Conditions (Evap 12°C/7°C - Air. 35°C)

(2) per motor

(3) per circuit

(4) Max rated conditions.

(5) Dual Pump Option

(6) For units with HESP option, contact your local sales office



General Data

Table 3 - CXAN reversible - Standard version - R407C

		CXAN 200	CXAN 250	CXAN 300	CXAN 400	CXAN 450	CXAN 490
Eurovent Performances (1)							
Net Cooling Capacity	(kW)	49.2	60.8	73.6	94.5	116.4	124.8
Total Power input in cooling	(kW)	20.3	25.4	30.1	40.0	42.8	49.7
Water pressure drop in cooling	(kPa)	28	31	35	39	40	39
Pressure available in cooling (5)	(kPa)	198	183	177	156	201	190
Net Heating Capacity	(kW)	48.1	59.6	72.7	99.2	112.3	120.3
Power input in heating	(kW)	20.3	24.9	30.4	43.0	45.7	48.7
Pressure drop in heating	(kPa)	26	30	35	43	37	36
Pressure available in heating (5)	(kPa)	200	185	179	146	205	195
Main Power supply		400/3/50	400/3/50	400/3/50	400/3/50	400/3/50	400/3/50
Units Amps							
Nominal (4)	(A)	47	57	69	89	89	89
Start-up Amps	(A)	148	203	215	236	236	236
Short circuit unit capacity	(kA)	10	10	10	10	10	10
Max supply cable size	(mm ²)	16	35	35	95	95	95
Min supply cable size	(mm ²)	10	16	16	50	50	50
Compressor							
Number		2	2	2	3	3	3
Type		Scroll	Scroll	Scroll	Scroll	Scroll	Scroll
Model		(10T+10T)	(10T+15T)	(15T+15T)	(15T+15T+10T)	(15T+15T+10T)	(15T+15T+10T)
Rated Amps (2)(4)	(A)	19+19	19+28.5	28.5+28.5	28.5+28.5+18.5	28.5+28.5+18.6	28.5+28.5+18.7
Locked rotor Amps (2)	(A)	120	175	175	175	176	177
Motor RPM	(rpm)	2900	2900	2900	2900	2900	2900
Power factor		0.84	0.85	0.85	0.85	0.87	0.87
Sump Heater (2)	(W)	100	160	160	50	50	50
Evaporator							
Number		1	1	1	1	1	1
Type		Brazed plate	Brazed plate	Brazed plate	Brazed plate	Brazed plate	Brazed plate
Water volume (total)	(l)	5.3	6.8	8.2	10.5	10.5	10.5
Antifreeze Heater	(W)	115	115	115	115	115	115
Unit Water Connections		Male ISO R7	Male ISO R7	Male ISO R7	Male ISO R7	Male ISO R7	Male ISO R7
Water Connections Diameter		2"	2"	2 1/2"	2 1/2"	2 1/2"	2 1/2"
Coil							
Type		Plate Fin	Plate Fin	Plate Fin	Plate Fin	Slit Fin	Slit Fin
Length	(mm)	2489	2489	2896	2896	2896	2896
Height	(mm)	1422	1422	1422	1626	1626	1626
Face Area (3)	(m ²)	3.54	3.54	4.12	4.71	4.71	4.71
Rows		2	3	3	3	4	4
Fins per inch	(fpf)	204	204	204	204	168	168
Fan							
Type		Propeller	Propeller	Propeller	Propeller	Propeller	Propeller
Number		2	2	3	3	3	3
Diameter	(mm)	710	710	710	800	800	800
Drive type		Direct drive	Direct drive	Direct drive	Direct drive	Direct drive	Direct drive
Air flow	(m ³ /h)	20200	19100	26300	37300	37100	37300
Motors Number		2	2	3	3	3	3
Motor HP (2)	(kW)	0.57	0.57	0.57	1.05	1.05	1.05
Rated Amps (2)	(A)	1.5	1.5	1.5	2.4	2.4	2.4
Motor RPM	(rpm)	700	700	700	680	680	680
Dimensions							
Height (6)	(mm)	1897	1897	1897	2048	2048	2048
Length	(mm)	2800	2800	3200	3200	3200	3200
Width	(mm)	1100	1100	1100	1100	1100	1100
Operating Weight	(kg)	776	870	996	1182	1302	1331
Shipping Weight	(kg)	771	862	982	1163	1295	1323
System Data							
Refrigerant circuit		1	1	1	1	1	1
Capacity steps		2	2	2	2	2	2
Minimum capacity	(%)	50	40/60	50	37/63	37/64	37/65
Refrigerant Charge (3)							
Circuit A	(kg)	13	18	21	24	40	40
Circuit B	(kg)	-	-	-	-	-	-

(1) at Eurovent Conditions (Cooling :Water 12°C/7°C - Air. 35°C // Heating :Water 40°C/45°C - Air. DB7°C / WB6°C)

(2) per motor

(3) per circuit

(4) Max rated conditions.

(5) Dual Pump Option

(6) For units with HESP option, contact your local sales office

General Data

Table 3 cont

		CXAN 500	CXAN 600	CXAN 700	CXAN 800	CXAN 900	CXAN 925
Eurovent Performances (1)							
Net Cooling Capacity	(kW)	125.9	153.1	167.4	195.1	220.7	251.9
Total Power input in cooling	(kW)	51.1	60.7	69.8	78.2	90.1	102.0
Water pressure drop in cooling	(kPa)	28	35	25	29	29	36
Pressure available in cooling (5)	(kPa)	209	189	208	191	148	134
Net Heating Capacity	(kW)	119.2	145.3	171.8	198.4	220.0	251.6
Power input in heating	(kW)	49.5	60.4	69.6	84.5	92.6	101.1
Pressure drop in heating	(kPa)	25	31	26	30	29	36
Pressure available in heating (5)	(kPa)	214	197	205	188	149	134
Main Power supply		400/3/50	400/3/50	400/3/50	400/3/50	400/3/50	400/3/50
Units Amps							
Nominal (4)	(A)	113	136	153	188	208	225
Start-up Amps	(A)	259	282	300	334	354	450
Short circuit unit capacity	(kA)	10	10	10	10	10	10
Max supply cable size	(mm ²)	95	95	150	150	150	150
Min supply cable size	(mm ²)	50	50	95	95	95	95
Compressor							
Number		4	4	6	6	6	4
Type		Scroll	Scroll	Scroll	Scroll	Scroll	Scroll
Model		(10T+15T)	(15T+15T)	(10T+10T+15T)	(15T+15T+10T)	(15T+15T+15T)	(25T+25T)
Rated Amps (2)(4)	(A)	2x(19+28.5)	2x(28.5+28.5)	2x(19+19+28.5)	2x(28.5+28.5+19)	2x(28.5+28.5+28.5)	2x(47+47)
Locked rotor Amps (2)	(A)	175	175	175	175	175	272
Motor RPM	(rpm)	2900	2900	2900	2900	2900	2900
Power factor		0.85	0.85	0.85	0.85	0.85	0.87
Sump Heater (2)	(W)	160	160	160	160	160	150
Evaporator							
Number		1	1	1	1	1	1
Type		Brazed plate	Brazed plate	Brazed plate	Brazed plate	Brazed plate	Brazed plate
Water volume (total)	(l)	172	19.8	25.6	29.0	35.7	35.7
Antifreeze Heater	(W)	180	180	180	180	180	180
Unit Water Connections		Male ISO R7	Male ISO R7	Male ISO R7	Male ISO R7	Male ISO R7	Male ISO R7
Water Connections Diameter		2 1/2"	2 1/2"	3"	3"	3"	3"
Coil							
Type		Plate Fin	Plate Fin	Plate Fin	Plate Fin	Plate Fin	Slit Fin
Length	(mm)	2489	2896	2896	2896	2896	2896
Height	(mm)	1422	1422	1626	1626	1626	1626
Face Area (3)	(m ²)	3.54	4.12	4.71	4.71	4.71	4.71
Rows		3	3	3	3	4	4
Fins per inch	(fpf)	204	204	204	204	180	168
Fan							
Type		Propeller	Propeller	Propeller	Propeller	Propeller	Propeller
Number		4	6	6	6	6	6
Diameter	(mm)	710	710	710	800	800	800
Drive type		Direct drive	Direct drive	Direct drive	Direct drive	Direct drive	Direct drive
Air flow	(m ³ /h)	38300	52700	55400	86300	83000	79300
Motors Number		4	6	6	6	6	6
Motor HP (2)	(kW)	0.57	0.57	0.57	1.4	1.4	1.4
Rated Amps (2)	(A)	1.5	1.5	1.5	4	4	4
Motor RPM	(rpm)	700	700	700	680	680	680
Dimensions							
Height (6)	(mm)	1897	1897	2100	2100	2100	2100
Length	(mm)	3400	3400	3400	3400	3400	3400
Width	(mm)	2300	2300	2300	2300	2300	2300
Operating Weight	(kg)	1677	1872	2166	2324	2502	2535
Shipping Weight	(kg)	1642	1832	2109	2260	2423	2456
System Data							
Refrigerant circuit		2	2	2	2	2	2
Capacity steps		4	4	4	4	4	4
Minimum capacity	(%)	20/30	25	22/29	19/32	17/33	17/33
Refrigerant Charge (3)							
Circuit A	(kg)	21	24	29	30	37	41
Circuit B	(kg)	21	24	29	30	37	41

(1) at Eurovent Conditions (Cooling :Water 12°C/7°C - Air. 35°C // Heating :Water 40°C/45°C - Air. DB7°C / WB6°C)

(2) per motor

(3) per circuit

(4) Max rated conditions.

(5) Dual Pump Option

(6) For units with HESP option, contact your local sales office



General Data

Table 4 - CXAN reversible - Super Quiet version - R407C

		CXAN 200	CXAN 250	CXAN 300	CXAN 400	CXAN 450	CXAN 490
Eurovent Performances (1)							
Net Cooling Capacity	(kW)	49.1	60.4	73.1	93.6	116.4	124.8
Total Power input in cooling	(kW)	19.9	25.2	29.8	37.6	42.8	49.7
Water pressure drop in cooling	(kPa)	27	31	35	38	40	39
Pressure available in cooling (5)	(kPa)	198	183	178	158	201	190
Net Heating Capacity	(kW)	48.1	59.6	72.7	99.2	112.3	120.3
Power input in heating	(kW)	19.6	24.2	29.3	39.8	45.7	48.7
Pressure drop in heating	(kPa)	26	30	35	43	37	36
Pressure available in heating (5)	(kPa)	200	185	179	146	205	195
Main Power supply		400/3/50	400/3/50	400/3/50	400/3/50	400/3/50	400/3/50
Units Amps							
Nominal (4)	(A)	46	55	66	90	102	111
Start-up Amps	(A)	147	202	213	236	327	336
Short circuit unit capacity	(kA)	10	10	10	10	10	10
Max supply cable size	(mm ²)	16	35	35	95	95	95
Min supply cable size	(mm ²)	10	16	16	50	50	50
Compressor							
Number		2	2	2	3	2	2
Type		Scroll	Scroll	Scroll	Scroll	Scroll	Scroll
Model		(10T+10T)	(10T+15T)	(15T+15T)	(15T+15T+10T)	(20T+25T)	(25T+25T)
Rated Amps (2)(4)	(A)	19+19	19+28.5	28.5+28.5	28.5+28.5+19	38+47	47+47
Locked rotor Amps (2)	(A)	120	175	175	175	272	272
Motor RPM	(rpm)	2900	2900	2900	2900	2900	2900
Power factor		0.84	0.85	0.85	0.85	0.87	0.87
Sump Heater (2)	(W)	100	160	160	160	150	150
Evaporator							
Number		1	1	1	1	1	1
Type		Brazed plate	Brazed plate	Brazed plate	Brazed plate	Brazed plate	Brazed plate
Water volume (total)	(l)	5.3	6.8	8.2	10.5	11.3	12.6
Antifreeze Heater	(W)	115	115	115	115	115	115
Unit Water Connections		Male ISO R7	Male ISO R7	Male ISO R7	Male ISO R7	Male ISO R7	Male ISO R7
Water Connections Diameter		2"	2"	2 1/2"	2 1/2"	2 1/2"	2 1/2"
Coil							
Type		Plate Fin	Plate Fin	Plate Fin	Plate Fin	Slit Fin	Slit Fin
Length	(mm)	2489	2489	2896	2896	2896	2896
Height	(mm)	1422	1422	1422	1626	1626	1626
Face Area (3)	(m ²)	3.54	3.54	4.12	4.71	4.71	4.71
Rows		2	3	3	3	4	4
Fins per inch	(fpf)	204	204	204	204	168	168
Fan							
Type		Propeller	Propeller	Propeller	Propeller	Propeller	Propeller
Number		2	2	3	3	3	3
Diameter	(mm)	710	710	710	800	800	800
Drive type		Direct drive	Direct drive	Direct drive	Direct drive	Direct drive	Direct drive
Air flow	(m ³ /h)	20200	19100	26300	37300	37100	37100
Motors Number		2	2	3	3	3	3
Motor HP (2)	(kW)	0.57	0.57	0.57	1.05	1.05	1.05
Rated Amps (2)	(A)	1.5	1.5	1.5	2.4	2.4	2.4
Motor RPM	(rpm)	700	700	700	680	680	680
Dimensions							
Height (6)	(mm)	1897	1897	1897	2048	2048	2048
Length	(mm)	2800	2800	3200	3200	3200	3200
Width	(mm)	1100	1100	1100	1100	1100	1100
Operating Weight	(kg)	806	900	1038	1194	1314	1343
Shipping Weight	(kg)	801	892	1024	1175	1307	1335
System Data							
Refrigerant circuit		1	1	1	1	1	1
Capacity steps		2	2	2	2	2	2
Minimum capacity	(%)	50	40/60	50	37/63	37/63	37/63
Refrigerant Charge (3)							
Circuit A	(kg)	13	18	21	24	40	40
Circuit B	(kg)	-	-	-	-	-	-

(1) at Eurovent Conditions (Cooling: Water 12°C/7°C - Air. 35°C / Heating: Water 40°C/45°C - Air. DB7°C / WB6°C)

(2) per motor

(3) per circuit

(4) Max rated conditions.

(5) Dual Pump Option

(6) For units with HESP option, contact your local sales office

General Data

Table 4 cont

		CXAN 500	CXAN 600	CXAN 700	CXAN 800	CXAN 900	CXAN 925
Eurovent Performances (1)							
Net Cooling Capacity	(kW)	125.5	152.5	166.8	194.1	219.2	250.0
Total Power input in cooling	(kW)	50.9	60.3	69.6	75.9	88.3	101.5
Water pressure drop in cooling	(kPa)	28	34	25	29	29	36
Pressure available in cooling (5)	(kPa)	209	190	209	192	149	135
Net Heating Capacity	(kW)	119.2	145.3	171.8	198.4	220.0	251.6
Power input in heating	(kW)	48.5	59.0	68.2	79.5	87.6	97.4
Pressure drop in heating	(kPa)	25	31	26	30	29	36
Pressure available in heating (5)	(kPa)	214	197	205	188	149	134
Main Power supply		400/3/50	400/3/50	400/3/50	400/3/50	400/3/50	400/3/50
Units Amps							
Nominal (4)	(A)	110	131	150	178	200	216
Start-up Amps	(A)	256	278	295	324	344	441
Short circuit unit capacity	(kA)	10	10	10	10	10	10
Max supply cable size	(mm ²)	95	95	150	150	150	150
Min supply cable size	(mm ²)	50	50	95	95	95	95
Compressor							
Number		4	4	6	6	6	4
Type		Scroll	Scroll	Scroll	Scroll	Scroll	Scroll
Model		(10T+15T)	(15T+15T)	(10T+10T+15T)	(15T+15T+10T)	(15T+15T+15T)	(25T+25T)
Rated Amps (2)(4)	(A)	2x(19+28.5)	2x(28.5+28.5)	2x(19+19+28.5)	2x(28.5+28.5+19)	2x(28.5+28.5+28.5)	2x(47+47)
Locked rotor Amps (2)	(A)	175	175	175	175	175	272
Motor RPM	(rpm)	2900	2900	2900	2900	2900	2900
Power factor		0.85	0.85	0.85	0.85	0.85	0.87
Sump Heater (2)	(W)	160	160	160	160	160	150
Evaporator							
Number		1	1	1	1	1	1
Type		Brazed plate	Brazed plate	Brazed plate	Brazed plate	Brazed plate	Brazed plate
Water volume (total)	(l)	17.2	19.8	25.6	29.0	35.7	35.7
Antifreeze Heater	(W)	180	180	180	180	180	180
Unit Water Connections		Male ISO R7	Male ISO R7	Male ISO R7	Male ISO R7	Male ISO R7	Male ISO R7
Water Connections Diameter		2 1/2"	2 1/2"	3"	3"	3"	3"
Coil							
Type		Slit Fin	Slit Fin	Slit Fin	Slit Fin	Slit Fin	Slit Fin
Length	(mm)	2489	2896	2896	2896	2896	2896
Height	(mm)	1422	1422	1626	1626	1626	1626
Face Area (3)	(m ²)	3.54	4.12	4.71	4.71	4.71	4.71
Rows		3	3	3	3	4	4
Fins per inch	(fpf)	204	204	204	204	180	168
Fan							
Type		Propeller	Propeller	Propeller	Propeller	Propeller	Propeller
Number		4	6	6	6	6	6
Diameter	(mm)	710	710	710	800	800	800
Drive type		Direct drive	Direct drive	Direct drive	Direct drive	Direct drive	Direct drive
Air flow	(m ³ /h)	38300	52700	55400	74700	71400	74300
Motors Number		4	6	6	6	6	6
Motor HP (2)	(kW)	0.57	0.57	0.57	1.05	1.05	1.05
Rated Amps (2)	(A)	1.5	1.5	1.5	2.4	2.4	2.4
Motor RPM	(rpm)	700	700	700	680	680	680
Dimensions							
Height (6)	(mm)	1897	1897	2100	2074	2074	2074
Length	(mm)	3400	3400	3400	3400	3400	3400
Width	(mm)	2300	2300	2300	2300	2300	2300
Operating Weight	(kg)	1739	1954	2250	2414	2592	2625
Shipping Weight	(kg)	1704	1914	2193	2350	2513	2546
System Data							
Refrigerant circuit		2	2	2	2	2	2
Capacity steps		4	4	4	4	4	4
Minimum capacity	(%)	20/30	25	22/29	19/32	17/33	17/33
Refrigerant Charge (3)							
Circuit A	(kg)	21	24	29	30	37	41
Circuit B	(kg)	21	24	29	30	37	41

(1) at Eurovent Conditions (Cooling: Water 12°C/7°C - Air. 35°C / Heating: Water 40°C/45°C - Air. DB7°C / WB6°C)

(2) per motor

(3) per circuit

(4) Max rated conditions.

(5) Dual Pump Option

(6) For units with HESP option, contact your local sales office

General Data

Table 5 - Hydraulic module and buffer tank

		CGAN CXAN 200	CGAN CXAN 250	CGAN CXAN 300	CGAN CXAN 400	CGAN CXAN 450	CGAN CXAN 490	CGAN CXAN 500	CGAN CXAN 600	CGAN CXAN 700	CGAN CXAN 800	CGAN CXAN 900	CGAN CXAN 925
Motor (2)	(kW)	2.2	2.2	2.2	2.2	4.0	2.2	4.0	4.0	4.0	4.0	5.5	5.5
Rated Amps (2)	(A)	4.9	4.9	4.9	4.9	4.9	7.5	7.5	7.5	7.5	7.5	11.1	11.1
Motor RPM	(rpm)	2900											
Water strainer Ø		2"	2"	2 1/2"	2 1/2"	2 1/2"	2 1/2"	2 1/2"	2 1/2"	3"	3"	3"	3"
Expansion tank volume	(L)	25	25	25	25	25	25	35	35	35	35	35	35
User volume expansion capacity (1)	(L)	1000	1000	1000	1000	1000	1 000	1400	1400	1400	1400	1400	1400
Antifreeze heater	(W)	150											
Piping material		Steel											
Hydraulic Module Weight	(kg)	103	103	108	108	108	108	110	110	114	114	189	189
Water tank volume (Option)	(L)	370	370	410	410	410	410	570	570	570	570	570	570
Water tank additional shipping height	(mm)	400											
Water tank additional shipping weight	(kg)	396	396	437	436	436	436	644	644	644	644	644	644

(1) Hydrostatic pressure 3 bar at 45°C with -12°C mini
 (2) Dual Pump Option

Installation

General unit characteristics

For minimum clearance, consult the certified submittals, which are available on request from your Trane sales office.

Unit nameplate

The unit nameplate gives the complete model reference numbers. The unit power rating is shown, and power supplies should not deviate by more than 5 % from the rated power. Compressor motor amperage is shown in box I.MAX. The customer's electrical installation must be able to withstand this current.

Installation instructions

Foundations

No special foundations are required, provided the supporting surface is flat and level, and can withstand the weight of the unit.

Isolating rubber pads

They are supplied as standard with the machine, and should be placed between the supporting floor and the unit to isolate from the ground.

- 4 pads for the sizes 200 - 490
- 6 pads for the sizes 500 - 925
- Trane does not recommend to install spring isolators.

Water drain hole

For units with an hydraulic module, condensates are to be collected below the pump and drained away.

Clearance

Respect recommended clearance around the unit to allow maintenance operation to take place without obstruction and recommended clearance around condenser.

Caution

Unit operation is function of the air temperature. Any recycling of the air fed out by the fans will increase the air intake temperature over the condenser fins and can result in high pressure cut-out.

In this case the standard operating conditions and performance are modified.

Operation of the unit may be affected by an increase in air temperature on the condenser. When the units are positioned in a windy area, avoid all the risks of air-cooled recycling. Refer to certified drawings.

Figure 1 - Handling - units without Buffer tank

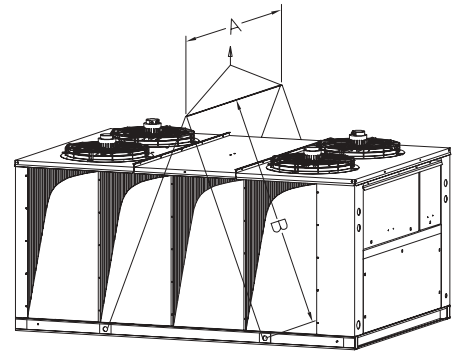

Note: The plates welded at the end of the bases must not be used for handling.

Figure 2 - Handling - units with buffer tank

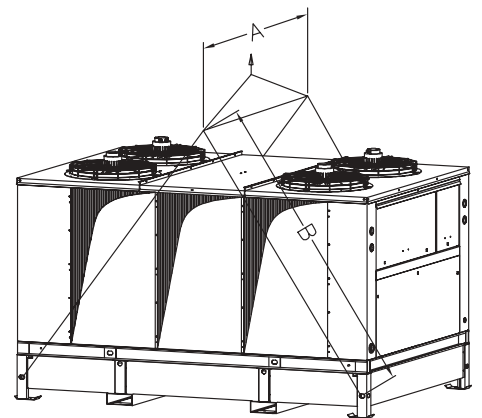

Installation

Table 6 - Dimensions of recommended slings and swing-bar :

	CGAN CXAN 200	CGAN CXAN 250	CGAN CXAN 300	CGAN CXAN 400	CGAN CXAN 450	CGAN CXAN 490	CGAN CXAN 500	CGAN CXAN 600	CGAN CXAN 700	CGAN CXAN 800	CGAN CXAN 900	CGAN CXAN 925
Without buffer tank												
A (mm)	1400	1400	1400	1400	1400	1400	2400	2400	2400	2400	2400	2400
B (mm)	2300	2300	2300	2500	2500	2500	3100	3100	3100	3100	3100	3100
With buffer tank												
A (mm)	1400	1400	1400	1400	1400	1400	2400	2400	2400	2400	2400	2400
B (mm)	2700	2700	2800	3100	3100	3100	3400	3400	3400	3400	3400	3400

Table 7 - Shipping weights

	CGAN CXAN 200	CGAN CXAN 250	CGAN CXAN 300	CGAN CXAN 400	CGAN CXAN 450	CGAN CXAN 490	CGAN CXAN 500	CGAN CXAN 600	CGAN CXAN 700	CGAN CXAN 800	CGAN CXAN 900	CGAN CXAN 925
Without hydraulic module												
CGAN (kg)	743	834	954	1124	1260	1284	1588	1778	2030	2181	2344	2377
CXAN (kg)	773	864	996	1136	1272	1296	1650	1860	2114	2271	2434	2467
Additional weight for single pump hydraulic module												
CGAN (kg)	29	29	34	34	64	64	66	66	70	70	84	84
CXAN (kg)												
Additional weight for double pump hydraulic module												
CGAN (kg)	103	103	108	108	108	108	110	110	114	114	189	189
CXAN (kg)												
Additional weight for buffer tank												
CGAN (kg)	396	396	437	436	436	436	644	644	644	644	644	644
CXAN (kg)												

Installation

Before making any connections, make sure the labeling for entering and leaving water corresponds to the submittals.

CGAN/CXAN units are available in 3 versions:

- Without hydraulic module (with or without contactors)
- With hydraulic module (single or dual pump)
- With hydraulic module and buffer tank.

Typical water circuits are given in figures 3 to 5

Figure 3 - Unit without hydraulic module - typical water circuit

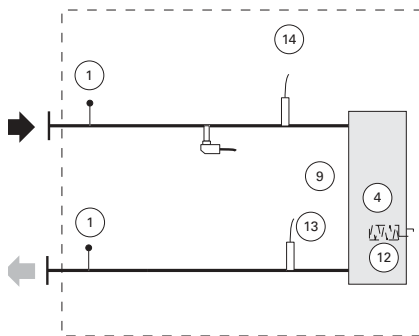

Figure 4 - Unit with hydraulic module - typical water circuit

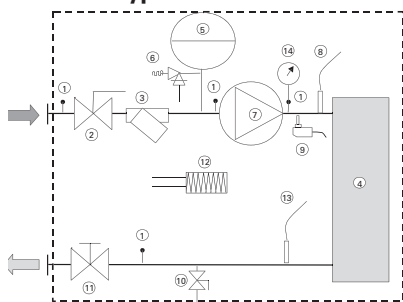
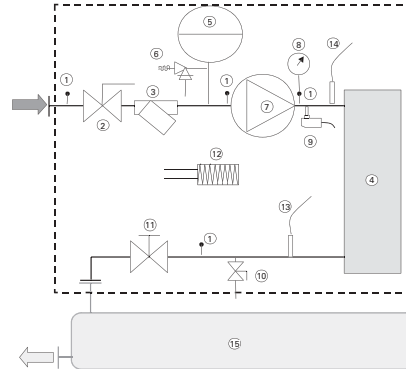

Figure 5 - Unit with hydraulic module and buffer tank - typical water circuit



Legend for figures 3 to 5

1. Pressure port for water gauge
2. Shut off ball valve
3. Water strainer
4. Evaporator
5. Expansion tank
6. Relief valve
7. Pump (single or dual)
8. Removable water gauge
9. Flow control
10. Filling and drain valve
11. Balancing valve
12. Freeze protection
13. Leaving water temperature sensor
14. Return water temperature sensor
15. Buffer tank

Warning: Units with hydraulic module and buffer tank content all safety and operation devices and only require the supply and return piping to be connected using expansion compensators. Units without hydraulic module have to be connected according to figure 6.

Figure 6 - Unit without hydraulic module and buffer tank - typical water circuit

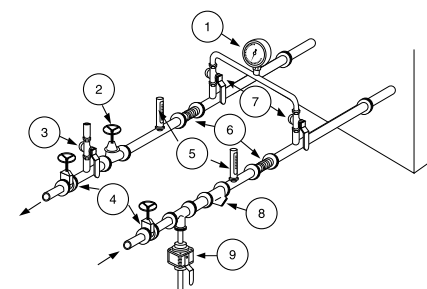
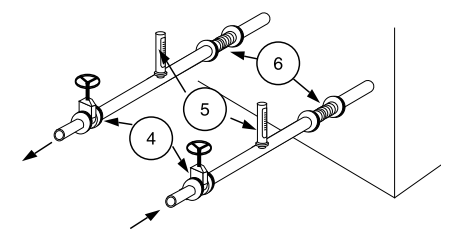

Figure 7 - Unit with hydraulic module and buffer tank - typical water circuit



- 1 Pressure gauges: show entering and leaving water pressure (2 pressure ports are available inside of the unit - see item 1 in figure 5)
- 2 Balancing valve: adjusts water flow.
- 3 Air purge allows to remove the air from the water circuit during fill up.
- 4 Stop valves: isolate chillers and water circuiting pump during maintenance operations.
- 5 Thermometers: indicate chilled water entering and leaving temperatures.
- 6 Expansion compensators: avoid mechanical stress between chiller and piping installation.
- 7 Stop valve located on the outlet connection: used to measure the water pressure inlet or outlet of evaporator.
- 8 Strainer: avoid to get heat exchangers dirty. All installation must be equipped with efficient strainer in order that only clean water enters into exchanger. If there is no strainer, reserve will be formulated by the Trane technician at the start-up of the unit. The strainer used must be able to stop all particles with a diameter greater than 0.8 mm.
- 9 Draining: used as the draining the plate heat exchanger.

To protect the environment, it is compulsory to recover and process glycol brines.

Installation

Minimal installation water content

The water volume is an important parameter because it allows a stable chilled water temperature and avoids short cycle operation of the compressors.

Parameters which influence the water temperature stability

- Water loop volume.
- Load fluctuation.
- Number of capacity steps.
- Compressors rotation.
- Dead band.
- Minimum time between 2 starts of a compressor.

Minimum water volume for a comfort application

For comfort application we can allow water temperature fluctuation at part load. The parameter to take into account is the minimum operating time of the compressor. In order to avoid lubrication problem on a scroll or an hermetic reciprocating compressor it must run at least 2 minutes (120 seconds) before it stops.

The minimum volume can be determined by using the following formula

$$\text{Volume} = \frac{\text{Cooling capacity} \times \text{Time} \times \text{highest capacity step (\%)} / \text{Specific heat} / \text{Dead band}}$$

Minimum operating time = 120 seconds
 Specific heat = 4.18 kJ / kg
 Dead band recommended = 3°C

Dead band calculation

Dead band = (Biggest compressors step tonnage / Total tonnage) X (Water temperature difference entry/leaving) + allowed water loop temperature fall
 Minimum allowed temperature fall = 1.5°C
 Minimum dead band calculation table versus the targeted water temperature delta T

It is preferable to have a higher dead band than the minimum recommended.

Unit size	Bigger Compressor tonnage step	Total unit Tonnage	Compressor step temperature fall versus Delta T water loop			Minimum recommended water loop temperature fall	Dead Band minimum versus delta T water loop		
			4	5	6		4	5	6
200	10	20	2.0	2.5	3.0	1.5	3.5	4.0	4.5
250	15	25	2.4	3.0	3.6	1.5	3.9	4.5	5.1
300	15	30	2.0	2.5	3.0	1.5	3.5	4.0	4.5
400	25	40	2.5	3.1	3.8	1.5	4.0	4.6	5.3
450	25	45	2.2	2.8	3.3	1.5	3.7	4.3	4.8
490	25	50	2.0	2.5	3.0	1.5	3.5	4.0	4.5
500	15	50	1.2	1.5	1.8	1.5	2.7	3.0	3.3
600	15	60	1.0	1.3	1.5	1.5	2.5	2.8	3.0
700	20	70	1.1	1.4	1.7	1.5	2.6	2.9	3.2
800	25	80	1.3	1.6	1.9	1.5	2.8	3.1	3.4
900	30	90	1.3	1.7	2.0	1.5	2.8	3.2	3.5
925	25	100	1.0	1.3	1.5	1.5	2.5	2.8	3.0

Installation

Minimum water volume for a process application or for a chiller which has to run with low ambient temperature option.

For Process application we have to minimize the water temperature fluctuation at part load. In order to avoid problem on a scroll or a hermetic reciprocating compressor it must run at least 2 minutes (120 seconds) before it stops and the minimum time between two starts is 5 minutes (300 seconds).

The water volume has to be able to provide the cooling capacity while the unit is shut down.

The minimum volume can be determined by using the following formula

$$\text{Volume} = \text{Cooling capacity} \times \text{Time} \times \text{highest capacity step (\%)} / \text{Specific heat} / \text{Dead band}$$

With these values the formula becomes

$$\text{Volume} = \text{Cooling capacity} \times 9.56 \times \text{highest capacity step (\%)}$$

For the CGAN running in following conditions: Air temperature 35°C, water 12/7°C, this gives the following volumes. If the total water volume of the installation is below the above mentioned values it is necessary to use a buffer tank.

Minimum time = 180 seconds (300-120)

Specific heat = 4.18 kJ / kg
Dead band recommended = Function of the process

With these values the formula becomes:

$$\text{Volume} = \text{Cooling capacity} \times 43 \times \text{highest capacity step (\%)} / \text{Dead band}$$

Increasing the dead band is like adding water volume to the loop.

Table 8 - Minimum water loop volume for comfort application

	CGAN CXAN 200	CGAN CXAN 250	CGAN CXAN 300	CGAN CXAN 400	CGAN CXAN 450	CGAN CXAN 490	CGAN CXAN 500	CGAN CXAN 600	CGAN CXAN 700	CGAN CXAN 800	CGAN CXAN 900	CGAN CXAN 925
Water volume (l)	250	360	360	610	640	620	370	370	500	650	760	630

At Eurovent conditions

Installation

Water treatment

Untreated or insufficiently treated water, if used in this unit, may cause scale, slime or algae to accumulate or cause erosion and corrosion.

As Trane does not know the components used in the hydraulic network and the quality of the water used, we recommend the services of a qualified water treatment specialist.

The following materials are used in Trane chillers heat exchangers:

- Stainless steel plates AISI 316, 1.4401 with copper brazing.
- Water piping: steel
- Water connections: brass

Trane will not accept any liability in regards of damage due to the use of untreated or improperly treated water or from the use of saline or brackish water.

If required, contact your local Trane sales office.

Winter freeze protection

During negative ambient air temperature chilled water piping must be fully insulated.

Ensure that all safeties are taken to prevent frost damage during negative ambient air temperature.

Following system can be used:

- Electrical heater mounted on all water piping exposed to negative temperatures.
- Start chilled water pump during negative ambient air temperature.
- Add ethylene glycol in the chilled water.
- Drain water-circuit, however be aware of corrosion process when drained.

Figure 8 - Freezing point versus ethylene glycol percentage

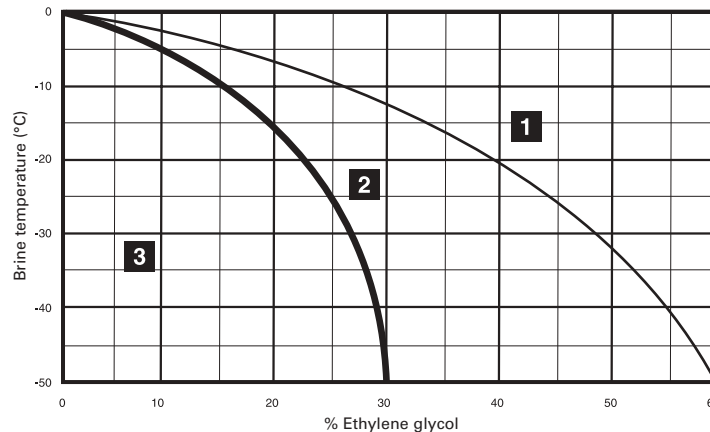

1. Liquid
2. Freezing without burst effect
3. Freezing with burst effect

Electrical connections

Caution:

1. The greatest care should be taken when cutting through passages and installing electric wiring. Under no circumstances should chips of metal or cuttings of copper or isolating material fall into the starter panel or electric components. Relays, contactors, terminals and control wiring should be covered and protected before power supplies are connected.
2. Install power supply cabling as shown in wiring diagram. Adequate cable gland should be chosen, ensuring no foreign bodies enter the electrical housing or components.

Caution:

1. Cabling must comply with standards in force. The type and location of fuses must also comply with standards. As a safety measure, fuses should be visibly installed, close to the unit.
2. Only copper wiring should be used. Using aluminium wires can produce galvanic corrosion and possibly lead to superheat and failure of connection points.

Expansion valves settings

In order to keep the compressor in the operating envelope, it is mandatory to control the superheat suction at commissioning. It shall reduce the compressor discharge gas temp and increase the saturated suction temperature, increasing by the way the unit capacity. The rule to reduce the suction superheat is to loosen the expansion valve adjustment screw. One turn counterclockwise equals to -1°C to -2°C superheat decrease. It is recommended to lower the superheat by increasing the suction pressure by making adjustments to the expansion valve setting prior to attempting to lower the LP setting parameter to avoid unit tripping on low pressure. Make sure there is enough subcooling. This can be convenient for units with Ethylene Glycol and Propylene Glycol.

Installation

Figure 9 - CGAN/CXAN 200 to 490 electrical connections

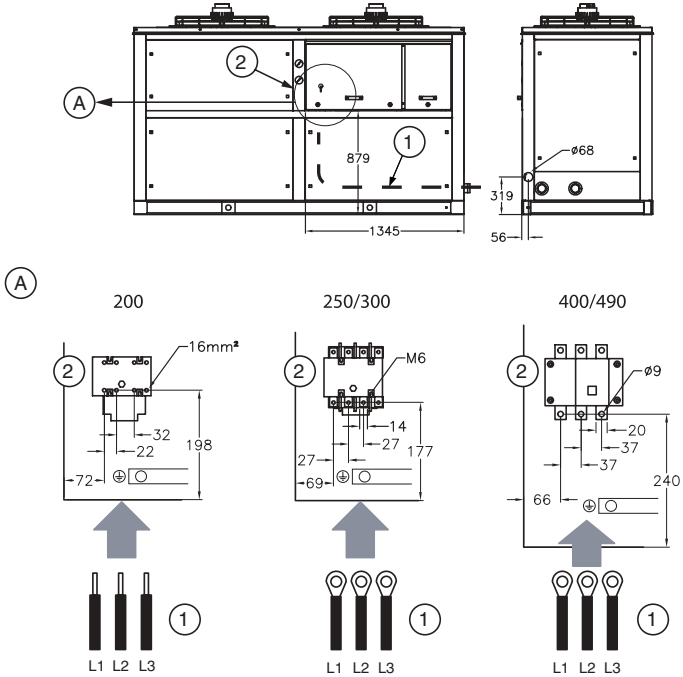
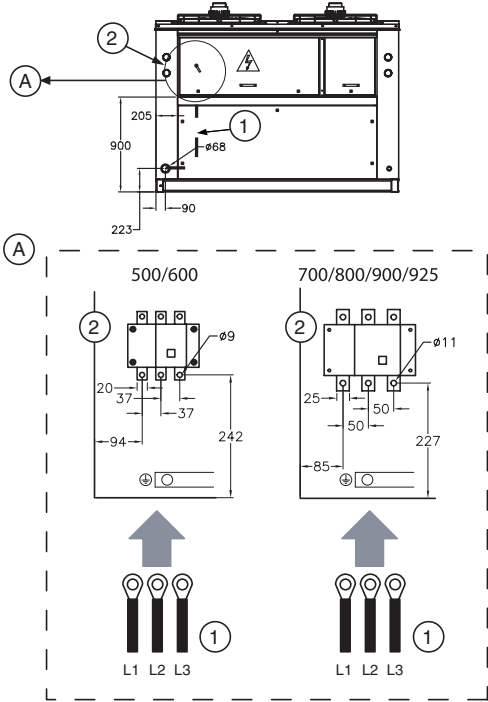

Figure 10 - CGAN/CXAN 500 to 925 electrical connections



- 1. Power supply cable (Field supply)
- 2. Unit disconnect switch

General start-up

START UP PREPARATION

Carry out all operations on check list so that the unit is correctly installed and ready to operate.

The installer must check all the following points before calling in the Trane Servicing Department to put the equipment into service:

- Check position of unit
- Check unit is level
- Check type and position of rubber pads
- Check clearance required for maintenance access (Refer to certified drawings)
- Check clearance around condenser (Refer to certified drawings)
- Chilled water circuit ready to operate, filled with water, pressure test carried out and air purged.
- Chilled water circuit must be rinsed
- Check the presence of water strainer ahead of evaporator
- The strainers must be cleaned after 2 hours of pumps operation
- Check the thermometers and manometers position
- Check chilled water pumps interconnection to control panel
- Ensure that the isolation resistance of all power supply terminals to ground complies with standards and regulations in force.
- Check that unit voltage and frequency supplied match rated input voltage and frequency
- Check that all electrical connections are clean and sound
- Check that main power supply switch is sound.
- Check Ethylene glycol or Propylene glycol % in the chilled water circuit.
- Water flow control checking: decrease the water flow and check the electrical contact in the control panel.
- Check chilled water pressure drop through evaporator (unit without hydraulic module) or unit available pressure (unit with hydraulic module) are in accordance with the Trane order write-up (See tables 9 to 11).
- On start-up of each motor in the system, check the direction of rotation and operation of all the components they drive

- Check that there is sufficient demand for cooling on the day of start-up (around 50% of nominal load)

START-UP

Follow the instructions below to correctly start-up the unit.

Installation and chiller inspection:

- Ensure that all the operations above (start-up preparation), are followed.
Follow the instruction stuck inside the electrical cabinet:
- Put the plexiglass supplied by Trane in front of the power terminal.
- Ensure all water and refrigerant valves are in service positions,
- Ensure that the unit is not damaged,
- Ensure that sensors are properly installed in their bulb-wells and submerged in heat conducting product,
- Check fixing of capillary tubes (protection from vibration and from wear) and ensure that they are not damaged,
- Reset all manually set control devices,
- Check refrigerating circuits tightness

Checking and setting:

Compressors:

- Check oil level at rest. The level should reach at least halfway up indicator located on housing. See fig. 11 for correct level.

Figure 11 - Compressor oil level

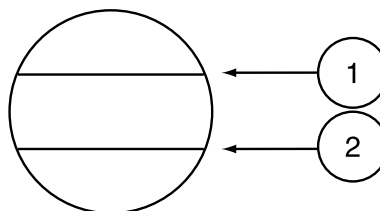

1. Max. oil level
2. Min. oil level

- Check fixing of capillary tubes (protection from vibration and from wear) and ensure that they are not damaged,
- Reset all manually set control devices,
- Check refrigerating circuits tightness
- Check electrical terminals tightening of the motors and in the control panel,
- Check the isolation of the motors using a 500V DC megohmmeter which meets manufacturer's specifications (minimum value 2 megohms)
- Check the direction of the rotation using phasemeter.

Electrical power wiring:

- Check all the electrical terminals tightening,
- Set-up compressors overload relays,
- Set-up fan-motors overload relays,

Electrical control wiring:

- Check all the electrical terminals tightening,
- Check all the pressostats,
- Check and set-up the TRACER CH532 control module
- Test and start-up without the electrical power.

Condenser:

- Check direction of the rotation of fans,
- Check the isolation of the motors using a 500V DC megohmmeter which meets manufacturer's specifications (minimum value 500 megohms)

Operating parameters statement:

- Switch on main power supply switch,
- Start the water pump(s) and check there is no cavitation.
- Start-up the unit following procedure described in the CH532 controller user guide.

The unit and the chilled water

- pumps contactor must be connected together,
- After unit start up, leave in operation for at least 15 minutes, to ensure pressures are stabilized.

Then check:

- voltage,
- compressors and fan-motors currents,

General start-up

- leaving and return chilled water temperature,
- suction temperature and pressure,
- ambient air temperature,
- blowing air temperature,
- discharge pressure and temperature,
- liquid refrigerant temperature and pressure,
- operating parameters:
- chilled water pressure drop through evaporator (if no hydraulic module is installed) or unit available pressure. It must be in accordance with Trane order write-up,
- superheat: difference between suction temperature and dew point temperature. Normal superheat should be within 4 and 7 °C with R407C in cooling mode,
- sub-cooling: difference between liquid temperature and bubble point temperature. Normal sub-cooling should be within 2 and 10°C with R407C in cooling mode,
- difference between dew point temperature in high pressure and condenser air inlet temperature. Normal value on standard unit with R407C, should be 15 to 23°C.
- difference between outlet water temperature and dew point temperature in low pressure. Normal value on standard unit, without Ethylene glycol in chilled water, should be about 3°C + superheat with R407C.

Final check:

When the unit is operating correctly

- Check that the unit is clean and clear of any debris, tools, etc...
- All valves are in operating position,
- Close control and starter panel doors and check panels fixation.

Caution:

- For the warranty to apply, any start-up carried out directly by the customer must be recorded in a detailed report, which must be sent as soon as possible to the nearest Trane office.
- Do not start-up a motor whose insulation resistance is less than 2 megohms

- Phase imbalance should not be greater than 2%.
- The voltage supplied to motors should be within 5% of the rated voltage on the compressor nameplate.
- Excessive emulsion of the oil in the compressor shows that refrigerant is present in the oil and the result will be that compressor is not lubricated enough.. Shut down compressor and wait for 60 minutes for the sump heaters to heat oil and start again. Should this not work, consult Trane technician.
- Excess oil in compressor can damage the compressor. Before adding oil, consult Trane technician. Use only Trane products recommended.
- The compressors must operate in a single direction of rotation. If refrigerant high pressure remains stable in the 30 seconds after compressor start-up, immediately shut down unit and check the direction of rotation using phasemeter.

Warning

- The chilled water circuit may be under pressure. Bring down this pressure before opening up the system to rise out or fill up the water circuit. Failure to comply with this instruction may cause accidental injury to maintenance personnel.
- If a cleaning solution is used in the chilled water circuit, the chiller must be isolated from the water circuit to avoid all the damage risks of the chiller and evaporator water pipes.

General start-up

Table 9 - Water pressure drop at nominal waterflow rate (Without Hydraulic module option)

		CGAN CXAN 200	CGAN CXAN 250	CGAN CXAN 300	CGAN CXAN 400	CGAN CXAN 450	CGAN CXAN 490	CGAN CXAN 500	CGAN CXAN 600	CGAN CXAN 700	CGAN CXAN 800	CGAN CXAN 900	CGAN CXAN 925
Min. waterflow rate - 0% EG	(l/s)	0.48	0.48	0.87	0.87	0.87	0.87	1.23	1.23	2.23	2.23	2.23	2.23
Min. waterflow rate - 30% EG	(l/s)	0.86	0.86	1.57	1.57	1.57	1.57	2.21	2.21	4.02	4.02	4.02	4.02
Nom. waterflow rate	(l/s)	2.43	2.99	3.64	4.92	5.83	6.33	6.17	7.52	8.75	10.25	11.55	12.78
Pressure drop nominal	(kPa)	29	33	38	46	43	45	30	36	30	35	35	42

Table 10 - Water pressure drop (Without Hydraulic module option)

ΔP kPa	Waterflow rate l/s												
	CGAN CXAN 200	CGAN CXAN 250	CGAN CXAN 300	CGAN CXAN 400	CGAN CXAN 450	CGAN CXAN 490	CGAN CXAN 500	CGAN CXAN 600	CGAN CXAN 700	CGAN CXAN 800	CGAN CXAN 900	CGAN CXAN 925	
	10	1.37	1.60	1.82	2.24	2.73	2.91	3.52	3.86	4.98	5.37	6.00	6.00
20	1.99	2.30	2.61	3.20	3.90	4.15	5.04	5.52	7.14	7.71	8.63	8.63	
40	2.87	3.33	3.75	4.57	5.59	5.93	7.20	7.90	10.25	11.07	12.41	12.41	
60	3.56	4.12	4.64	5.63	6.90	7.30	8.88	9.74	12.65	13.67	15.35	15.35	
80	4.15	4.80	5.39	6.53	8.01	8.46	10.30	11.31	14.70	15.89	17.85	17.85	
100	4.68	5.40	6.06	7.33	8.99	9.48	11.56	12.69	16.50	17.85	20.06	20.06	

Table 11 - Available pressure at unit connection (With Hydraulic module option)

Water flow rate	200		250		300		400		450		490						
	Available pressure		Available pressure		Available pressure		Available pressure		Available pressure		Available pressure						
	1P kPa	2P kPa	1P kPa	2P kPa	1P kPa	2P kPa	1P kPa	2P kPa	1P kPa	2P kPa	1P kPa	2P kPa					
1.45	224	202	1.79	219	199	2.18	217	198	2.95	203	189	3.33	240	231	3.62	235	225
1.69	218	197	2.09	212	193	2.54	207	191	3.44	191	176	3.89	232	221	4.22	225	213
2.18	205	186	2.68	191	177	3.27	185	171	4.43	160	142	5.00	213	200	5.43	200	186
2.42	195	179	2.98	180	166	3.63	174	158	4.92	139	121	5.55	201	187	6.03	186	171
2.66	185	171	3.28	168	154	3.99	160	144	5.41	116	97	6.11	188	173	6.63	170	154
3.15	164	149	3.87	141	126	4.72	128	110	6.40	64	44	7.22	159	141	7.84	130	11
3.39	152	137	4.17	126	109	5.08	110	91	6.89	34	16	7.77	140	122	8.44	108	87
3.87	127	111	4.77	90	71	5.81	67	48	7.87	-	-	8.88	100	79	9.65	58	34

Table 11 (continued)

Water flow rate	500		600		700		800		900		925						
	Available pressure		Available pressure		Available pressure		Available pressure		Available pressure		Available pressure						
	1P kPa	2P kPa	1P kPa	2P kPa	1P kPa	2P kPa	1P kPa	2P kPa	1P kPa	2P kPa	1P kPa	2P kPa					
3.68	242	231	4.49	235	222	5.23	240	227	6.15	234	219	6.93	181	182	7.49	177	178
4.30	235	223	5.24	225	211	6.10	233	218	7.18	224	207	8.09	172	173	8.74	167	168
5.53	217	203	6.74	201	185	7.84	211	192	9.23	193	171	10.40	150	151	11.24	141	141
6.14	207	191	7.49	186	168	8.71	197	176	10.25	174	148	11.55	137	137	12.49	125	124
6.75	195	179	8.24	168	148	9.58	182	159	11.28	151	121	12.71	122	121	13.74	107	103
7.98	166	147	9.74	128	104	11.32	143	113	13.33	98	62	15.02	86	81	16.24	63	57
8.60	149	129	10.49	103	77	12.19	121	88	14.35	67	28	16.17	64	59	17.49	38	31
9.82	113	89	11.98	50	18	13.94	71	32	16.40	-	-	18.48	16	9	19.98	-	-

1P = Single pump - 2P = Dual pump

General start-up

Figure 12 - CGAN/CXAN 200 - 400 pump curve

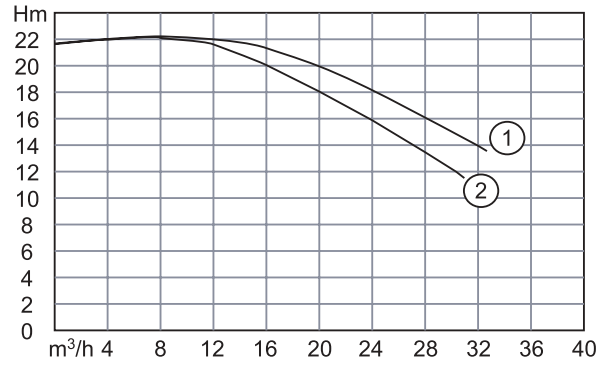

- 1. Single pump
- 2. Dual pump

Figure 13 - CGAN/CXAN 450 - 800 pump curve

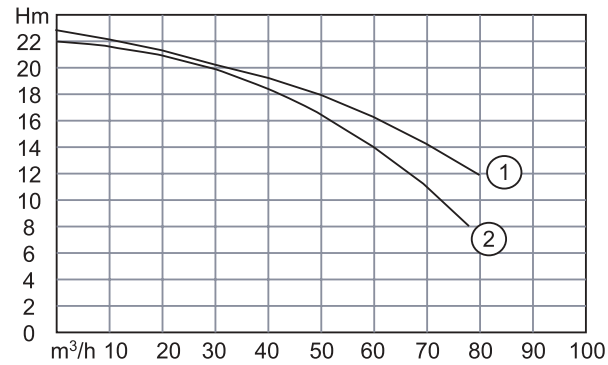

- 1. Single pump
- 2. Dual pump

Figure 14 - CGAN/CXAN 900 - 925 pump curve

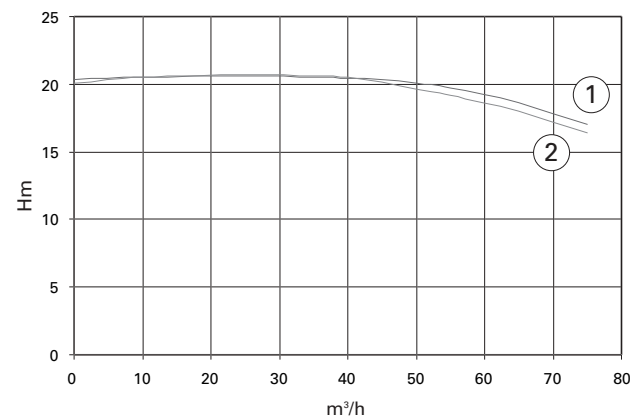

- 1. Single pump
- 2. Dual pump

General start-up

When ethylene glycol is added in the chilled water circuit the following adjustment factors have to be taken in account.

Table 13 - Ethylene glycol adjustment factors

LWTE	PCT EG (%)	Adjustment factors			
		Flow rate	Pressure drop	Power Input	Cooling Cap.
12	30	1.11	1.20	1.005	0.98
5	30	1.11	1.24	1.005	0.98
4	10	1.02	1.08	-	-
0	20	1.05	1.19	-	-
-4	27	1.08	1.29	-	-
-8	33	1.10	1.46	-	-
-12	37	1.12	1.62	-	-

Ethylene Glycol recommended concentration

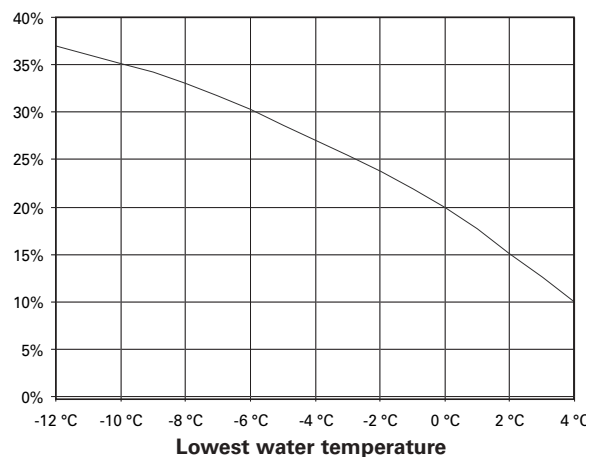

Propylene Glycol recommended concentration

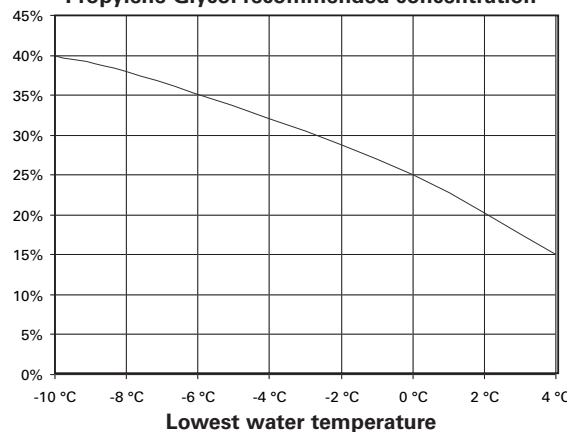

A relief valve is located at pump suction limiting water circuit pressure at 3 bar.
Nitrogen pressure inside of the expansion tank must be equal to the geometric height of the installation + 0.5 bar (in order to avoid air entering in the water circuit)

Expansion tank must be inflated with nitrogen. Pressure must be checked yearly.
For a good pump operation, pump suction pressure must be between 0.5 and 2.5 bar when pump runs.

Operation

Control System

The control is through the TRACER CH532 control module.

Unit operations

- Check the chilled water pump(s) operates
- Start up the unit following procedure described in the CH532 controller user guide. The unit will operate correctly when there is sufficient water flow. The compressors will start up if the evaporator water leaving temperature is above the control module setpoint.

Weekly start up

- Check the chilled water pump(s) operates
- Start up the unit following procedure described in the CH532 controller user guide.

Weekend shutdown

- If the unit needs to be shut down for a short period of time, stop the unit following procedure described in the CH532 controller user guide. (See "Clock" menu)
- If the unit is shut down for a longer period, see under "Seasonal shutdown", below.
- Ensure that all safeties are taken to prevent frost damages during negative ambient temperature.
- Do not put the general disconnect switches to off, except if the unit is drained. Trane does not recommend draining the unit, due to the fact that it increases tube corrosion.

Seasonal shutdown

- Check water flows and interlocks.
- Check glycol % in the chilled water circuit if glycol presence is required
- Carry out leak test.
- Carry out oil analysis
- Record operating pressures, temperatures, amperages and voltage.
- Check operation of machines/compare conditions of operation against original commissioning data.

- Stop the unit following procedure described in the CH532 controller user guide.
- Ensure that all safeties are taken to prevent frost damages during negative ambient temperature.
- Fill out the visit log sheet and review with the operator - Do not put the general disconnect switch to off, except if the unit is drained. Trane does not recommend draining the unit, due to the fact that it increases tube corrosion.

Seasonal start-up

- Check water flows and interlocks.
- Check Ethylene glycol % in the chilled water circuit if glycol presence is required
- Check operational set points and performance.
- Calibrate controls.
- Check operation of all safety devices.
- Inspect contacts and tighten terminals.
- Megger the motor compressor windings.
- Record operating pressures, temperatures, amperages and voltage.
- Carry out leak test.
- Check configuration of unit control module.
- Change the oil as required based upon results of the oil analysis made during seasonal shutdown

Get the 8 condition measurements at the same time, on each circuit.

- HP
 - LP
 - Suction temperature
 - Discharge temperature
 - Liquid temperature
 - Water entering temperature
 - Water leaving temperature
 - Outdoor ambient temperature
- Then calculate the sub-cooling and superheat. No diagnosis can be accurate with one of these records missing.
- Check operation of machines/compare conditions of operation against original commissioning data.
 - Fill out the visit log sheet and review with the operator

Maintenance

Maintenance Instructions

The following maintenance instructions are part of maintenance operations required for this equipment. A qualified technician is needed for regular maintenance as part of a regular maintenance contract. Carry out all operations as required by schedule. This will ensure long unit service life and reduce the possibility of serious and costly breakdown.

Keep service records up to date, showing monthly information on unit operations. These records can be of great help to maintenance personnel diagnostics. Similarly, if machine operator keeps a log of changes in unit operating conditions, problems can be identified and solutions found before more serious problems arise.

Inspection visit after the first 500 hours of operation from unit start up

- Carry out oil analysis
- Carry out leak test.
- Inspect contacts and tighten terminals.
- Record operating pressures, temperatures, amperages and voltage.
- Check operation of machines/compare conditions of operation against original commissioning data.
- Fill out inspection visit log sheet and review with the operator
- Check and clean the strainer

Monthly preventive visit

- Carry out leak test.
- Oil test of acidity
- Check Ethylene glycol % in the chilled water circuit if glycol presence is required
- Inspect contacts and tighten terminals.
- Record operating pressures, temperatures, amperages and voltage.
- Check operation of machines/compare conditions of operation against original commissioning data.
- Fill out visit log sheet and review with the operator.
- Check and clean the strainer.

Annual preventive visit

- Check water flows and interlocks.
- Check expansion tank pressure.
- Check glycol % in the chilled water circuit if glycol presence is required
- Check operational set points and performance.
- Calibrate controls and pressure transducer.
- Check operation of all safety devices.
- Inspect contacts and tighten terminals.
- Megger the motor compressor windings.
- Record operating pressures, temperatures, amperages and voltage.
- Carry out leak test.
- Check configuration of unit control module.
- Carry out oil analysis
- Change the oil as required based upon results of the oil analysis
- Check operation of machines/compare conditions of operation against original commissioning data.
- Fill out the annual start up visit log sheet and review with the operator.
- Check and clean the strainer.

Caution:

- Please refer to specific Trane documentation on oil, available from your nearest Trane office. Oils recommended by Trane have been exhaustively tested in Trane laboratories to the specific requirement of Trane chiller and hence the user's requirements.

Any use of oils not meeting specifications recommended by Trane is the responsibility of the user only, who thereby is liable to warranty loss.

- Oil analysis and oil test acidity must be carried out by a qualified technician. Poor interpretation of results may cause unit operating problems. Also, oil analysis must follow the correct procedures, to avoid accidental injury to maintenance personnel.
- If the condensers are dirty, clean them with a soft brush and water. If the coils are too dirty, consult a cleaning professional. Never use high pressure water to clean condenser coils.
- Contact Trane Service for information on maintenance contracts.

Warning:

- Switch off unit main power supply before to any intervention. Failure to follow this safety instruction can lead to accident death of the maintenance personnel and may also destroy equipment.
- Never use steam or hot water above 60°C to clean condenser coils. The resulting increasing pressure could cause refrigerant lost through the safety valve.

Pump maintenance

Pumps motor bearings and mechanical seals have a designed life expectancy of 20000-25000 hours of operation. For critical applications it might be necessary to change the components as a preventive measure.



Maintenance

This list must be checked off by the installer to ensure correct installation before the unit start up.

UNIT POSITION

- Check clearance around condenser
- Check clearance required for maintenance access
- Check type and position of rubbers pads
- Check unit is level

CHILLED WATER CIRCUIT

- Check thermometers and manometers presence and position
- Check water flow rate balancing valve presence and position
- Check presence of strainer ahead of evaporator
- Check presence of air-purge valve
- Check rinsing and filling of chilled water pipes
- Check water pump(s) contactor interconnected to control panel
- Check water flow
- Check chilled water pressure drop or unit available pressure (units with hydraulic module)
- Check for leaks in chilled water pipes

ELECTRICAL EQUIPMENT

- Check installation and rating of mains power switch/fuses
- Check electrical connections complied with specification
- Check that electrical connections are in accordance with information on manufacturer's identification plate
- Check direction of rotation using phasemeter

Comments

.....

.....

.....

.....

.....

Signature:.....Name:.....

Order N°:

Work site:

Please return to your local Trane Service Office



Troubleshooting guide

These are simple diagnostic hints. If there is a breakdown, the Trane Service office should be contacted for confirmation and assistance.

Problems symptoms	Problem causes	Action recommended
A) The compressor does not start up		
Compressor terminals are live but motor does not start	Motor burned out.	Replace compressor
Contact motor not operational.	Coil burned out or broken contacts.	Repair or replace.
No current ahead of motor contactor.	a) Power cut. b) Main power supply switched off.	Check fuses and connection. See why system tripped. If system is operational, switch on main power supply.
Current ahead of fuse, but not on contactor side.	Fuse blown.	Check motor insulation. Replace fuse.
Low voltage reading on voltmeter.	Voltage too low.	Contact power Supply Utility.
Starter coil not excited.	Regulation circuit open.	Locate regulation device which has tripped out and see why. See instructions concerning this device.
Compressor does not run. Compressor motor "groans". High pressure switch tripped to contacts open on high pressure. Discharge pressure too high.	Compressor sticking (damaged or sticking components). Discharge pressure too high	See instructions for "discharge pressure high".
B) Compressor stops		
High pressure switch tripped.		
Over current thermal relay tripped.	Discharge pressure too high. a) Voltage too low.	See instructions for "discharge pressure high".
Motor temperature thermostat tripped.	b) Cooling demand too high, or condensing temperature too high.	a) Contact Power Supply Utility.
Anti-freeze security tripped.	Not enough cooling fluid. Water flow to evaporator too low.	b) See instruction "discharge pressure too high". Repair leak. Add refrigerant. Check water flow rate, and flow switch contact in water
C) Compressor stops just after its start		
Suction pressure too low.	Filter drier clogged.	Replace filter drier.
Filter drier iced up.		

Troubleshooting guide

Problems symptoms	Problem cause	Action recommended
D) The compressor keeps running without stopping		
Temperature too high in areas requiring air-conditioning.	Excess load on cooling system.	Check thermal insulation and air-tightness of areas requiring air-conditioning.
Chilled water temperature output too high.	Excess cooling demand on system.	Check thermal insulation and air-tightness of areas requiring air-conditioning.
E) Loss of oil in compressor		
Oil level too low in indicator.	Not enough oil.	Contact Trane office before to order oil
Gradual fall in oil level.	Filter drier clogged.	Replace filter drier.
Suction line too cold. Compressor noisy	Liquid flows back to compressor.	Adjust superheat and check bulb fixing of the expansion valve.
F) Compressor noisy		
Compressor knocks.	Components broken in compressor.	Change compressor.
Suction duct abnormally cold.	a) Uneven liquid flow. b) Expansion valve locked in open position.	a) Check superheat setting and fixing of expansion valve bulb. b) Repair or replace.
G) Insufficient cooling capacity		
Thermostatic expansion valve "whistles".	Not enough refrigerant.	Check refrigerant circuit tightness and add refrigerant.
Excess pressure drops through filter drier	Drier filter clogged.	Replace.
Excessive superheat.	Superheat not properly adjusted.	Check adjustment of superheat and adjust thermostatic expansion valve.
Insufficient water flow.	Chilled water pipes obstructed.	Clean pipes and strainer.
H) Discharge pressure too high		
Condenser abnormally hot.	Presence of uncondensable liquids in system, or excess refrigerant.	Purge uncondensable fluids and drain off excess refrigerant.
Chilled water leaving temperature too high.	Overload on cooling system.	Reduce load on system. Reduce water flow if necessary.
Condenser air output too hot.	Reduced air flow. Air intake temperature higher than specified for unit	Clean or replace air filters. Clean coil. Check operation of motor fans.
I) Suction pressure too high		
Compressor operates continuously. Suction duct abnormally cold.	Excess cooling demand on evaporator a) Expansion valve too far open.	Check system. a) Check for superheat and check that expansion valve bulb is secure. b) Replace.
Refrigerant flows back to compressor.	b) Expansion valve locked in open position.	
J) Suction pressure too low		
Excessive pressure drop through filter drier. Refrigerant does not flow through thermostatic expansion valve.	Filter drier clogged. Expansion valve bulb has lost its refrigerant.	Replace the filter drier. Replace the bulb.
Loss of power.	Expansion valve obstructed.	Replace.
Superheat too low.	Excessive pressure drops through evaporator.	Check adjustment of superheat and adjust thermostatic expansion valve.
K) Insufficient cooling capacity		
Low pressure drops through evaporator	Low water flow rate.	Check water flow rate. Check state of strainer, check for obstruction in chilled water pipes. Check pressure switch contact in water.

Caution:

The above is not a comprehensive analysis of the Scroll compressor refrigeration system. The aim is to give operators simple instructions on basic unit processes so that they have the technical knowledge to identify and bring defective operations to the notice of qualified technicians.



Quality Management
System Approval



LONMARK®
SPONSOR



Literature Order Number	CG-SVX01C-E4
Date	0805
Supersedes	CG-SVX01B-E4_0204
Literature Stocking Location	Europe

Trane has a policy of continuous product and product data improvement and reserves the right to change design and specifications without notice. Only qualified technicians should perform the installation and servicing of equipment referred to in this publication.

www.trane.com

For more information, contact your local sales office or e-mail us at comfort@trane.com

American Standard Europe BVBA

Registered Office: 1789 Chaussée de Wavre, 1160 Brussels - Belgium