

Water chillers water/water type SIGMA



Technical information manual

Technical information manual SIGMA

REF.SIGMA-10230000012_04.08/SIGMA_2011.DOC

INDEX

Technical features	1
Versions	3
Accessory versions	4
Technical data	7
Electrical data	11
Cooling capacity	12
Heating capacity	18
Total heat recovery capacity	25
Technical data	26
Electrical data	30
Cooling capacity	31
Heating capacity	37
Total heat recovery capacity	45
Fouling factor corrections	46
Ethylene glycol mixtures	47
Low temperatures corrections factors	48
Sounds levels	49
Operating limits	51
Condenser pressure drop	52
Evaporator pressure drop	54
Dimensions, weights and hydraulic connections	55
Installation recommendations	68

Technical information manual SIGMA

REF.SIGMA-10230000012_04.08/SIGMA_2011.DOC

TECHNICAL FEATURES

SIGMA 2002 - Water chillers

STRUCTURE

Self supporting frame, constructed in galvanized sheet steel with RAL 7032 powder paint baked at 180°C to provide a durable weatherproof finish. Models 3.2 to 7.2 and model 14.4 are completely enclosed by painted steel panels fully lined with a sound absorbing material. On models 8.2 to 13.2 only the upper compartment, which contains the compressors, is fully enclosed on all sides by painted steel panels fully lined with a sound absorbing material. On models 8.2 to 13.2 only the upper compartment, which contains the compressors, and the separator between this compartment and the lower part of the unit are enclosed by painted steel panels fully lined with a sound absorbing material. Models 16.4 to 26.4 do not have panels.

COMPRESSORS

Hermetic scroll type with orbital motion, connected in tandem and equipped with oil level sight glass, Klixon internal thermal protection and oil equalisation line.

EVAPORATOR AND CONDENSER

Brazed plate type in 316 AISI stainless steel. Thermal insulation of evaporator is provided by closed cell expanded material. Each evaporator is equipped with a low water temperature probe for freeze protection and each unit is equipped as standard with a mechanical flow switch.

REFRIGERANT CIRCUIT

Comprising: liquid valve, charge connection, liquid sight-glass, filter/dryer, thermostatic expansion valve with external pressure equalisation, high and low pressure switches for 2-compressor models. For 4-compressor models high and low pressure values and relative condensation and evaporation temperatures are measured by pressure transducers that relay the signals to the controller so that they can be read directly on the display. The high pressure side of the circuit is equipped with high pressure switches and relief valves.

Technical information manual SIGMA

REF.SIGMA-10230000012_04.08/SIGMA_2011.DOC

ELECTRICAL PANEL

The electrical panel includes:

- main switch
- fuses for the auxiliary and power circuit
- compressor contactors
- microprocessor mCHILLER for 2 compressor units and PCO² for 4 compressors units, controlling the following functions:
 - water temperature regulation
 - freeze protection
 - compressor time intervals
 - compressor start sequence and automatic lead/lag selection
 - alarm reset
 - common alarm contact for remote signalling
 - operating and alarm indicator LEDs
- LCD display of the following information:
 - water inlet and outlet temperature
 - programmed temperature set-point and differential
 - alarms description
 - compressor hours run meter for units with PCO² control
 - number of starts of the unit and the compressors
 - high and low pressure values and relative condensation and evaporation temperature values

Electrical power supply [V/f/Hz]: 400/3~/50 ±5%

CONTROLS AND SAFETY DEVICES

- High pressure switch with manual reset
- High pressure safety, with manual reset, controlled by the unit controller on four compressors models
- Low pressure safety switch, with manual reset, controlled by the unit controller for four compressor models, low pressure switch, with manual reset, controlled by the unit microprocessor for the two compressors models
- High pressure relief valve
- Chilled water temperature sensor (at the evaporator inlet); on four compressors model it is installed on one evaporator only.
- Freeze protection sensor at the outlet of each evaporator
- Mechanical flow switch supplied as standard as kit with the unit
- Compressor over-temperature protection

TESTING

The units are subjected to a dry run in the factory and supplied complete with oil and refrigerant.

Technical information manual SIGMA

REF.SIGMA-10230000012_04.08/SIGMA_2011.DOC

SIGMA UNIT VERSIONS

SIGMA 2002/HP: reverse cycle heat pump

The heat pump version operates as a water cooled chiller in summer and a water to water heat pump in winter by reversing the refrigerant flow to suit the required operating mode. In addition to the components of version SIGMA 2002, the heat pump version includes:

REFRIGERANT CIRCUIT:

4-way reversing valve and a second thermostatic expansion valve.

ELECTRICAL PANEL:

Microprocessor programmed for summer/winter changeover (the Macroplus microprocessor is used on 4 compressor HP units).

SIGMA 2002/LE: motorcondensing unit

The unit is designed to operate with a remotely located refrigerant to air evaporator. It is supplied without a refrigerant to water evaporator and thermostatic expansion valve. The solenoid valve on the liquid line is supplied as standard. Models 3.2 to 13.2 have mchiller control and the remainder of the range is supplied without control. The standard supply is ON/OFF for each compressor from a digital entry.

SIGMA 2002/LE/HP: motorcondensing unit

The unit is designed to operate with a remotely located refrigerant to air evaporator. It is supplied without a refrigerant to water evaporator and thermostatic expansion valve. The solenoid valve on the liquid line and liquid receivers are supplied as standard. Models 3.2 to 13.2 have mCHILLER control and the remainder of the range is supplied without control. The standard supply is ON/OFF for each compressor from a digital entry.

SIGMA 2002/LC: motorevaporating unit

The unit is supplied without a water cooled condenser and is designed to be connected to a remotely located air cooled condenser.

SIGMA 2002/LC/HP: motoevaporating unit

The unit is supplied without a water cooled condenser and is designed to be connected to a remotely located air cooled condenser. The solenoid valve on the liquid line and the liquid receivers are supplied as standard

ACCESSORY VERSIONS

SIGMA 2002/DC: unit with heat recovery condenser

Not available for HP versions. In addition to the components of version SIGMA 2002 this unit includes a 100% heat recovery condenser, for the production of hot water, and a liquid receiver on each refrigerant circuit.

SIGMA 2002/DS: unit with desuperheaters

Available for all models. A brazed plate type heat recovery exchanger (desuperheater) is arranged in series with the condenser. Also available on all HP models. In this case an isolating valve must be fitted on the water recovery circuit and be closed during heat pump mode operation as described in the manual.

SIGMA LN: low noise unit

Low noise units are completely enclosed with painted steel panels lined with sound absorption material having an intermediate layer of high acoustic impedance material.

Technical information manual SIGMA

REF.SIGMA-10230000012_04.08/SIGMA_2011.DOC

REFRIGERANT CIRCUIT ACCESSORIES

- Compressor suction and discharge valves

Ball valve fitted in the equalisation line

- Pressostatic valve (with solenoid valve on heat pump)

- Liquid line solenoid valve

- Pressure gauges

On all units with a PCO2 controller the suction and discharge pressures are displayed on the controller. Gauges on standard units are located inside the compressor compartment.

- Liquid receivers (standard on versions /LE/HP and LC/HP LC/DC and DC)

- Dual set-point

With double thermostatic expansion valves and solenoid valves, the evaporator of "double set point units" is sized on the basis of high temperature operation. On units with mCHILLER control, the set must be manually modified on the microprocessor control panel. On units with PCO2 control the two values can be set from the keypad or via a digital input. In all cases the commutation between the two thermostatic expansion valves is automatic on the basis of the water temperature. Thermostatic expansion valve selection is made according to the temperature values specified at the the temperature values specified at the time of order. The operating limits remain unchanged and are as per the catalogue. If glycol is used, in a sufficient percentage to avoid freezing, the lower limit of the leaving water is extended to a minimum of -5 °C.

- Condenser for well water (only standard version and LE).

HYDRAULIC CIRCUIT ACCESSORIES

- Leaving water temperature control

Available only on units with control PCO2 (not HP versions).

- Water manifold

(only 4 compressors models). Available for condensers, evaporators and heat recovery.

ELECTRICAL ACCESSORIES

- Power factor correction $\cos \varnothing 0.9$ at nominal operating conditions

- Single voltage-free contacts for machine status signals

- Serial interface.

In units with a mCHILLER controller (3.2-13.2) the serial interface is the RS485 type with a Carel protocol. In units with a PCO2 control (from 14.4-26.4 excluding HP versions) the serial interface is the RS485 type with a Modbus protocol. Special protocols can be ordered: Carel; Echelon in RS485 or FTT10 versions. HP units can be supplied with a Macroplus microprocessor controller with a RS422 type serial interface; refer to the manual enclosed with the unit.

- Remote user terminal panel

(in addition to the standard terminal) Not available on HP units (with a Macroplus controller)

- Set point variable with remote signal

(0-1V, 0-10V, 0-4mA, 0-20mA) available only on units with a PCO2 controller, only in cooling mode. At the time of order. The set point values must be specified at the time of order.

Technical information manual SIGMA

REF.SIGMA-10230000012_04.08/SIGMA_2011.DOC

VARIOUS ACCESSORIES

- Rubber antivibration mountings
- Timber crate packing
- Pallet/skid for shipment in a container
- Non-standard RAL paint colours
- **Unit completely pre-assembled**, the unit will be supplied without refrigerant charge, test and PED certificate
- **Modular pre-assembled unit, only 4 compressors models**, with the exception of model 14.4.

Technical information manual SIGMA

REF.SIGMA-10230000012_04.08/SIGMA_2011.DOC

TECHNICAL DATA



GRANDEZZA UNITA'		3.2	4.2	5.2	6.2	UNIT SIZE
Raffreddamento^(*)						Cooling^(*)
Resa nominale	kW	42,4	51,2	59,8	68,9	Nominal capacity
Portata acqua evaporatore	l/s (l/h)	2,025 7,290	2,445 8,800	2,857 10,285	3,292 11,851	Water flow rate evaporator
Perdita di carico evaporatore	kPa	49,9	45,5	39,6	36,2	Pressure drop evaporator
Portata acqua condensatore	l/s (l/h)	2,497 8,988	3,006 10,822	3,503 12,612	4,045 14,563	Water flow rate condenser
Perdita di carico condensatore	kPa	37,9	37,9	39,4	27,1	Pressure drop condenser
Riscaldamento^(**)						Heating^(**)
Resa nominale	kW	51,2	61,7	71,9	83	Nominal capacity
Portata acqua condensatore	l/s (l/h)	2,447 8,809	2,949 10,616	3,435 12,367	3,967 14,280	Water flow rate condenser
Perdita di carico condensatore	kPa	72,5	65,9	57	51,5	Pressure drop condenser
Portata acqua evaporatore	l/s (l/h)	1,843 6,636	2,216 7,979	2,59 9,324	2,997 10,788	Water flow rate evaporator
Perdita di carico evaporatore	kPa	21,2	20,9	22	15,3	Pressure drop evaporator
Compressori	tipo	scroll	scroll	scroll	scroll	Compressors
Quantità	n	2	2	2	2	Number
Potenza assorbita raffredd. ^(*)	kW	9,9	11,8	13,5	15,8	Cooling power input ^(*)
Potenza assorbita riscald. ^(**)	kW	12,6	15,3	17,7	20,3	Heating power input ^(**)
Gradini di parzializzazione	%	0-50-100	0-50-100	0-50-100	0-50-100	Capacity steps
Carica refrigerante						Refrigerant charge
Versione chiller	kg	1 x 3,8	1 x 4,8	1 x 5,9	1 x 8,5	Chiller version
Versione pompa di calore	kg	1 x 4,3	1 x 5,1	1 x 6,1	1 x 6,6	Heat pump version
Olio						Oil
Carica olio	l	2 x 3,3	2 x 3,25	2 x 3,8	1 x 4 + 1 x 3,8	Oil charge
Marca olio		maneurop	maneurop	maneurop	maneurop	Oil producer
Tipo olio		160 SZ	160 SZ	160 SZ	160 SZ	Oil type
Evaporatore	tipo	piastre	piastre	piastre	piastre	Evaporator
Contenuto acqua evaporatore	l	1 x 2,9	1 x 3,8	1 x 4,9	1 x 5,5	Heat exchanger water volume
Max pressione esercizio lato acqua	bar	30	30	30	30	Max. operating pressure water side
Condensatore	tipo	piastre	piastre	piastre	piastre	Condenser
Contenuto acqua condensatore	l	1 x 3,1	1 x 3,9	1 x 4,7	1 x 7,5	Condenser water volume
Max pressione esercizio lato acqua	bar	30	30	30	30	Max. operating pressure water side
Dimensioni e pesi						Dimension and weight
Lunghezza	mm	1.334	1.334	1.334	1.334	Length
Profondità	mm	797	797	797	797	Width
Altezza	mm	962	962	962	962	Height
Peso di spedizione	kg	379	403	414	447	Shipping weight

(*) Evaporator entering/leaving temperature 12-7 °C;
Condenser entering/leaving temperature 30-35 °C

(**) Condenser entering/leaving temperature 40-45 °C;
Evaporator entering/leaving temperature 15-10 °C.

Technical information manual SIGMA

REF.SIGMA-10230000012_04.08/SIGMA_2011.DOC

TECHNICAL DATA



GRANDEZZA UNITA'		7.2	8.2	9.2	10.2	UNIT SIZE
Raffreddamento^(*)						Cooling^(*)
Resa nominale	kW	78	89,9	105,9	121,8	Nominal capacity
Portata acqua evaporatore	l/s (l/h)	3,727 13.418	4,296 15.467	5,058 18.210	5,82 20.953	Water flow rate evaporator
Perdita di carico evaporatore	kPa	35,4	35	41,4	37	Pressure drop evaporator
Portata acqua condensatore	l/s (l/h)	4,587 16.513	5,291 19.048	6,236 22.449	7,18 25.849	Water flow rate condenser
Perdita di carico condensatore	kPa	26,3	27,5	27,7	30	Pressure drop condenser
Riscaldamento^(**)						Heating^(**)
Resa nominale	kW	94,1	108,7	128,3	147,8	Nominal capacity
Portata acqua condensatore	l/s (l/h)	4,498 16.193	5,193 18.695	6,128 22.062	7,064 25.429	Water flow rate condenser
Perdita di carico condensatore	kPa	50,5	50,2	59,3	53,4	Pressure drop condenser
Portata acqua evaporatore	l/s (l/h)	3,404 12.253	3,91 14.075	4,615 16.613	5,32 19.150	Water flow rate evaporator
Perdita di carico evaporatore	kPa	14,8	15,4	15,6	16,8	Pressure drop evaporator
Compressori	tipo	scroll	scroll	scroll	scroll	Compressors
Quantità	n	2	2	2	2	Number
Potenza assorbita raffredd. ^(*)	kW	18	20,8	24,6	28,5	Cooling power input ^(*)
Potenza assorbita riscald. ^(**)	kW	22,9	26,9	31,7	36,5	Heating power input ^(**)
Gradini di parzializzazione	%	0-50-100	0-50-100	0-50-100	0-50-100	Capacity steps
Carica refrigerante						Refrigerant charge
Versione chiller	kg	1 x 9,9	1 x 11,4	1 x 12,9	1 x 15,9	Chiller version
Versione pompa di calore	kg	1 x 7,7	1 x 9	1 x 10,4	1 x 13	Heat pump version
Olio						Oil
Carica olio	l	2 x 4	2 x 6,6	1 x 8 + 1 x 6,6	2 x 8	Oil charge
Marca olio		maneurop	maneurop	maneurop	maneurop	Oil producer
Tipo olio		160 SZ	160 SZ	160 SZ	160 SZ	Oil type
Evaporatore	tipo	plastre	plastre	plastre	plastre	Evaporator
Contenuto acqua evaporatore	l	1 x 6,3	1 x 7,4	1 x 8,4	1 x 10,5	Heat exchanger water volume
Max pressione esercizio lato acqua	bar	30	30	30	30	Max. operating pressure water side
Condensatore	tipo	plastre	plastre	plastre	plastre	Condenser
Contenuto acqua condensatore	l	1 x 8,75	1 x 10	1 x 11,25	1 x 13,75	Condenser water volume
Max pressione esercizio lato acqua	bar	30	30	30	30	Max. operating pressure water side
Dimensioni e pesi						Dimension and weight
Lunghezza	mm	1.334	1.356	1.356	1.356	Length
Profondità	mm	797	768	768	768	Width
Altezza	mm	962	1.700	1.700	1.700	Height
Peso di spedizione	kg	470	483	560	648	Shipping weight

(*) Evaporator entering/leaving temperature 12-7 °C;
Condenser entering/leaving temperature 30-35 °C

(**) Condenser entering/leaving temperature 40-45 °C;
Evaporator entering/leaving temperature 15-10 °C.

Technical information manual SIGMA

REF.SIGMA-10230000012_04.08/SIGMA_2011.DOC

TECHNICAL DATA



GRANDEZZA UNITA'		12.2	13.2	14.4	16.4	UNIT SIZE
Raffreddamento^(*)						Cooling^(*)
Resa nominale	KW	133,7	146,9	154,2	177	Nominal capacity
Portata acqua evaporatore	l/s (l/h)	6,389 23.000	7,021 25.275	7,365 26.514	8,455 30.440	Water flow rate evaporator
Perdita di carico evaporatore	KPa	33,1	34,1	33,4	32,7	Pressure drop evaporator
Portata acqua condensatore	l/s (l/h)	7,848 28.255	8,623 31.044	9,026 32.495	10,369 37.329	Water flow rate condenser
Perdita di carico condensatore	kPa	29,9	26,7	24,5	25,5	Pressure drop condenser
Riscaldamento^(**)						Heating^(**)
Resa nominale	KW	166,1	183,3	189,2	216,8	Nominal capacity
Portata acqua condensatore	l/s (l/h)	7,937 28.574	8,758 31.528	9,038 32.538	10,36 37.298	Water flow rate condenser
Perdita di carico condensatore	kPa	49,9	51,9	49,1	48,1	Pressure drop condenser
Portata acqua evaporatore	l/s (l/h)	6,081 21.893	6,716 24.177	6,939 24.979	7,942 28.590	Water flow rate evaporator
Perdita di carico evaporatore	kPa	18,3	16,5	14,8	15,3	Pressure drop evaporator
Compressori	tipo	scroll	scroll	scroll	scroll	Compressors
Quantità	n	2	2	4	4	Number
Potenza assorbita raffredd. ^(*)	KW	30,6	33,5	34,8	40,1	Cooling power input ^(*)
Potenza assorbita riscald. ^(**)	KW	38,8	42,7	43,9	50,6	Heating power input ^(**)
Gradini di parzializzazione	%	0-50-100	0-50-100	0-50-100	0-25-50-75-100	Capacity steps
Carica refrigerante						Refrigerant charge
Versione chiller	kg	1 x 17,4	1x 20,7	2 x 9,9	2x 11,4	Chiller version
Versione pompa di calore	kg	1 x 14,4	1 x 17,8	2 x 7,7	2 x 9	Heat pump version
Olio						Oil
Carica olio	l	2 x 8	2 x 8	4 x 4	4 x 6,6	Oil charge
Marca olio		maneurop	maneurop	maneurop	maneurop	Oil producer
Tipo olio		160 P	160 P	160 P	160 P	Oil type
Evaporatore	tipo	plastre	plastre	plastre	plastre	Evaporator
Contenuto acqua evaporatore	l	1 x 11,6	1 x 14,3	2 x 6,3	2 x 7,4	Heat exchanger water volume
Max pressione esercizio lato acqua	bar	30	30	30	30	Max. operating pressure water side
Condensatore	tipo	plastre	plastre	plastre	plastre	Condenser
Contenuto acqua condensatore	l	1 x 15	1 x 17,5	2 x 8,75	2 x 10	Condenser water volume
Max pressione esercizio lato acqua	bar	30	30	30	30	Max. operating pressure water side
Dimensioni e pesi						Dimension and weight
Lunghezza	mm	1.356	1.356	1.426	2.476	Length
Profondità	mm	768	768	801	768	Width
Altezza	mm	1.700	1.700	1.787	1.700	Height
Peso di spedizione	kg	688	741	810	928	Shipping weight

(*) Evaporator entering/leaving temperature 12-7 °C;
Condenser entering/leaving temperature 30-35 °C

(**) Condenser entering/leaving temperature 40-45 °C;
Evaporator entering/leaving temperature 15-10 °C.

Technical information manual SIGMA

REF.SIGMA-1023000012_04.08/SIGMA_2011.DOC

TECHNICAL DATA



GRANDEZZA UNITA'		18.4	20.4	24.4	26.4	UNIT SIZE
Raffreddamento^(*)						Cooling^(*)
Resa nominale	KW	209	241	267,4	293,9	Nominal capacity
Portata acqua evaporatore	l/s (l/h)	9,985 35.944	11,514 41.449	12,778 46.000	14,042 50.550	Water flow rate evaporator
Perdita di carico evaporatore	KPa	39	35	33,1	34,1	Pressure drop evaporator
Portata acqua condensatore	l/s (l/h)	12,258 44.130	14,147 50.931	15,697 56.509	17,247 62.088	Water flow rate condenser
Perdita di carico condensatore	kPa	25,8	28,1	29,9	26,7	Pressure drop condenser
Riscaldamento^(**)						Heating^(**)
Resa nominale	KW	257,4	297,9	332,3	366,6	Nominal capacity
Portata acqua condensatore	l/s (l/h)	12,297 44.268	14,233 51.238	15,874 57.147	17,516 63.056	Water flow rate condenser
Perdita di carico condensatore	kPa	57,6	52,3	49,9	51,9	Pressure drop condenser
Portata acqua evaporatore	l/s (l/h)	9,418 33.904	10,894 39.218	12,163 43.786	13,432 48.354	Water flow rate evaporator
Perdita di carico evaporatore	kPa	15,6	17	18,3	16,5	Pressure drop evaporator
Compressori	tipo	scroll	scroll	scroll	scroll	Compressors
Quantità	n	4	4	4	4	Number
Potenza assorbita raffredd. ^(*)	KW	47,6	55,1	61,1	67,1	Cooling power input ^(*)
Potenza assorbita riscald. ^(**)	KW	60,3	69,9	77,7	85,5	Heating power input ^(**)
Gradini di parzializzazione	%	0-25-50-75-100	0-25-50-75-100	0-25-50-75-100	0-25-50-75-100	Capacity steps
Carica refrigerante						Refrigerant charge
Versione chiller	kg	2 x 12,9	2 x 15,9	2 x 17,4	2 x 20,7	Chiller version
Versione pompa di calore	kg	2 x 10,4	2 x 13	2 x 14,4	2 x 17,8	Heat pump version
Olio						Oil
Carica olio	l	2 x 8 + 2 x 6,6	4 x 8	4 x 8	4 x 8	Oil charge
Marca olio		maneurop	maneurop	maneurop	maneurop	Oil producer
Tipo olio		160 P	160 P	160 P	160 P	Oil type
Evaporatore	tipo	plastre	plastre	plastre	plastre	Evaporator
Contenuto acqua evaporatore	l	2 x 8,4	2 x 10,5	2 x 11,6	2 x 14,3	Heat exchanger water volume
Max pressione esercizio lato acqua	bar	30	30	30	30	Max. operating pressure water side
Condensatore	tipo	plastre	plastre	plastre	plastre	Condenser
Contenuto acqua condensatore	l	2 x 11,25	2 x 13,75	2 x 15	2 x 17,5	Condenser water volume
Max pressione esercizio lato acqua	bar	30	30	30	30	Max. operating pressure water side
Dimensioni e pesi						Dimension and weight
Lunghezza	mm	2.476	2.476	2.476	2.476	Length
Profondità	mm	768	768	768	768	Width
Altezza	mm	1.700	1.700	1.700	1.700	Height
Peso di spedizione	kg	1.069	1.210	1.226	1.270	Shipping weight

(*) Evaporator entering/leaving temperature 12-7 °C;
Condenser entering/leaving temperature 30-35 °C

(**) Condenser entering/leaving temperature 40-45 °C;
Evaporator entering/leaving temperature 15-10 °C.

Technical information manual SIGMA

REF.SIGMA-1023000012_04.08/SIGMA_2011.DOC

ELECTRICAL CHARACTERISTICS



GRANDEZZA UNITA'		3.2	4.2	5.2	6.2	UNIT SIZE
Raffreddamento⁽¹⁾						Cooling⁽¹⁾
Potenza massima assorbita ⁽¹⁾	KW	16,4	19,4	24,4	27,3	Maximum absorbed power ⁽¹⁾
Corrente massima allo spunto	A	115	150	145	175	Maximum starting current
Corrente massima assorbita ⁽²⁾	A	34	40	50	54	Full load current ⁽²⁾
Alimentazione elettrica	V/f/Hz	400/3~/50	400/3~/50	400/3~/50	400/3~/50	Power supply
Alimentazione ausiliari	V/f/Hz	230~/50	230~/50	230~/50	230~/50	Control power supply

GRANDEZZA UNITA'		7.2	8.2	9.2	10.2	UNIT SIZE
Raffreddamento⁽¹⁾						Cooling⁽¹⁾
Potenza massima assorbita ⁽¹⁾	KW	30,2	36,2	41,4	46,6	Maximum absorbed power ⁽¹⁾
Corrente massima allo spunto	A	179	210	250	265	Maximum starting current
Corrente massima assorbita ⁽²⁾	A	58	70	85	100	Full load current ⁽²⁾
Alimentazione elettrica	V/f/Hz	400/3~/50	400/3~/50	400/3~/50	400/3~/50	Power supply
Alimentazione ausiliari	V/f/Hz	230~/50	230~/50	230~/50	230~/50	Control power supply

GRANDEZZA UNITA'		12.2	13.2	14.4	16.4	UNIT SIZE
Raffreddamento⁽¹⁾						Cooling⁽¹⁾
Potenza massima assorbita ⁽¹⁾	KW	51,6	56,6	60,4	72,4	Maximum absorbed power ⁽¹⁾
Corrente massima allo spunto	A	320	339	237	280	Maximum starting current
Corrente massima assorbita ⁽²⁾	A	119	138	116	140	Full load current ⁽²⁾
Alimentazione elettrica	V/f/Hz	400/3~/50	400/3~/50	400/3~/50	400/3~/50	Power supply
Alimentazione ausiliari	V/f/Hz	230~/50	230~/50	230~/50	230~/50	Control power supply

GRANDEZZA UNITA'		18.4	20.4	24.4	26.4	UNIT SIZE
Raffreddamento⁽¹⁾						Cooling⁽¹⁾
Potenza massima assorbita ⁽¹⁾	KW	82,8	93,2	103,2	113,2	Maximum absorbed power ⁽¹⁾
Corrente massima allo spunto	A	335	365	439	477	Maximum starting current
Corrente massima assorbita ⁽²⁾	A	170	200	238	276	Full load current ⁽²⁾
Alimentazione elettrica	V/f/Hz	400/3~/50	400/3~/50	400/3~/50	400/3~/50	Power supply
Alimentazione ausiliari	V/f/Hz	230~/50	230~/50	230~/50	230~/50	Control power supply

(1) Mains power supply to allow unit operation

(2) Maximum current before safety cut-outs stop the unit. This value is never exceeded and must be used to size the electrical supply cables and relevant safety devices (refer to electrical wiring diagram supplied with the unit).

Technical information manual SIGMA
REF.SIGMA-10230000012_04.08/SIGMA_2011.DOC

COOLING CAPACITY



MODELLO MODEL	T ₀ [°C]	Temperatura acqua uscita condensatore [°C] Condenser outlet water temperature [°C]														
		30			35			40			45			50		
		kWf	kWe	kWr	kWf	kWe	kWr	kWf	kWe	kWr	kWf	kWe	kWr	kWf	kWe	kWr
3.2	6	42,8	8,8	51,7	40,9	9,9	50,8	38,8	11,0	49,8	36,4	12,3	48,8	33,9	13,8	47,6
	7	44,4	8,9	53,2	42,4	9,9	52,3	40,2	11,0	51,2	37,8	12,3	50,1	35,1	13,8	48,9
	8	45,9	8,9	54,8	43,9	9,9	53,8	41,6	11,0	52,7	39,1	12,4	51,5	36,4	13,8	50,2
	9	47,5	8,9	56,4	45,4	9,9	55,3	43,1	11,0	54,1	40,5	12,3	52,8	37,6	13,8	51,4
	10	49,2	8,8	58,0	47,0	9,9	56,8	44,6	11,0	55,6	41,9	12,3	54,2	38,9	13,8	52,7
4.2	6	51,8	10,4	62,2	49,4	11,7	61,1	46,8	13,2	60,0	43,9	14,9	58,8	40,7	16,7	57,5
	7	53,6	10,5	64,1	51,2	11,8	62,9	48,5	13,2	61,7	45,5	14,9	60,4	42,2	16,8	59,0
	8	55,5	10,5	66,0	52,9	11,8	64,7	50,1	13,3	63,4	47,0	15,0	62,0	43,6	16,8	60,5
	9	57,3	10,5	67,9	54,7	11,8	66,6	51,8	13,3	65,2	48,6	15,0	63,7	45,1	16,9	62,0
	10	59,3	10,6	69,8	56,6	11,9	68,4	53,6	13,4	66,9	50,3	15,0	65,3	46,7	16,9	63,6
5.2	6	60,5	12,0	72,5	57,8	13,5	71,3	54,7	15,2	69,9	51,3	17,2	68,4	47,5	19,4	66,9
	7	62,6	12,1	74,7	59,8	13,5	73,3	56,6	15,2	71,9	53,1	17,2	70,3	49,2	19,4	68,6
	8	64,8	12,1	76,9	61,9	13,6	75,4	58,6	15,3	73,9	55,0	17,3	72,2	51,0	19,5	70,4
	9	67,0	12,1	79,1	64,0	13,6	77,6	60,6	15,3	75,9	56,9	17,3	74,2	52,7	19,5	72,3
	10	69,2	12,2	81,4	66,1	13,6	79,8	62,6	15,4	78,0	58,8	17,4	76,1	54,5	19,6	74,1
6.2	6	69,7	14,1	83,7	66,6	15,7	82,3	63,1	17,6	80,7	59,3	19,7	79,0	55,1	22,0	77,2
	7	72,1	14,1	86,2	68,9	15,8	84,7	65,3	17,6	83,0	61,4	19,8	81,2	57,1	22,1	79,2
	8	74,6	14,2	88,7	71,3	15,8	87,1	67,6	17,7	85,3	63,6	19,8	83,4	59,1	22,2	81,3
	9	77,1	14,2	91,3	73,7	15,9	89,6	69,9	17,8	87,7	65,8	19,9	85,7	61,2	22,3	83,4
	10	79,7	14,3	94,0	76,2	15,9	92,1	72,3	17,8	90,1	68,0	20,0	87,9	63,3	22,3	85,6
7.2	6	78,8	16,1	94,9	75,4	17,9	93,3	71,5	20,0	91,5	67,4	22,2	89,6	62,8	24,7	87,5
	7	81,6	16,2	97,7	78,0	18,0	96,0	74,1	20,1	94,1	69,7	22,3	92,1	65,0	24,8	89,8
	8	84,4	16,2	100,6	80,7	18,1	98,8	76,6	20,1	96,8	72,2	22,4	94,6	67,3	24,9	92,2
	9	87,3	16,3	103,5	83,5	18,1	101,6	79,3	20,2	99,5	74,6	22,5	97,1	69,6	25,0	94,6
	10	90,2	16,3	106,5	86,3	18,2	104,5	81,9	20,3	102,2	77,2	22,6	99,8	72,0	25,1	97,1
8.2	6	91,0	18,6	109,6	86,9	20,7	107,7	82,4	23,2	105,6	77,5	26,0	103,5	72,1	29,1	101,3
	7	94,2	18,6	112,8	89,9	20,8	110,7	85,3	23,3	108,6	80,2	26,1	106,3	74,6	29,3	103,9
	8	97,4	18,7	116,1	93,0	20,9	113,9	88,2	23,4	111,6	82,9	26,2	109,2	77,2	29,4	106,6
	9	100,6	18,8	119,4	96,1	21,0	117,1	91,2	23,5	114,7	85,7	26,3	112,1	79,8	29,5	109,3
	10	104,0	18,8	122,8	99,3	21,1	120,4	94,2	23,6	117,8	88,6	26,4	115,0	82,5	29,6	112,1
9.2	6	107,2	22,0	129,2	102,3	24,5	126,8	97,0	27,4	124,4	91,4	30,6	122,0	85,3	34,3	119,5
	7	110,9	22,1	133,0	105,9	24,6	130,5	100,4	27,5	128,0	94,6	30,8	125,4	88,3	34,4	122,7
	8	114,7	22,2	136,9	109,5	24,8	134,3	103,9	27,7	131,6	97,8	31,0	128,8	91,3	34,6	125,9
	9	118,6	22,3	140,9	113,2	24,9	138,1	107,4	27,8	135,2	101,2	31,1	132,3	94,4	34,8	129,2
	10	122,6	22,4	145,0	117,0	25,0	142,0	111,0	28,0	139,0	104,6	31,3	135,8	97,6	35,0	132,6
10.2	6	123,3	25,5	148,8	117,7	28,3	146	111,7	31,5	143,2	105,3	35,2	140,5	98,4	39,4	137,8
	7	127,6	25,6	153,2	121,8	28,5	150,3	115,6	31,7	147,4	109	35,5	144,4	101,9	39,6	141,5
	8	132	25,8	157,8	126	28,6	154,7	119,6	31,9	151,6	112,7	35,7	148,4	105,4	39,9	145,3
	9	136,5	25,9	162,5	130,3	28,8	159,1	123,7	32,1	155,8	116,6	35,9	152,5	109	40,1	149,1
	10	141,1	26,1	167,2	134,7	29	163,7	127,9	32,3	160,2	120,5	36,1	156,7	112,7	40,4	153,1

kWf : cooling capacity [kW]
kWe : compressors power input [kW]
kWe : total recovery heating capacity [kW]
T₀ : evaporator leaving water temperature [°C]

Inlet/outlet evaporator water thermal difference 5°C
Inlet/outlet condenser water thermal difference 5°C

Technical information manual SIGMA
REF.SIGMA-1023000012_04.08/SIGMA_2011.DOC

COOLING CAPACITY



MODELLO MODEL	T ₀ [°C]	Temperatura acqua uscita condensatore [°C] Condenser outlet water temperature [°C]														
		30			35			40			45			50		
		kWf	kWe	kWr	kWf	kWe	kWr	kWf	kWe	kWr	kWf	kWe	kWr	kWf	kWe	kWr
12.2	6	136,2	28	164,1	130,6	31,3	161,9	124,5	35	159,5	117,6	39,2	156,8	110,1	43,7	153,8
	7	140,9	28,1	169	135,2	31,5	166,6	128,8	35,2	164	121,7	39,4	161,1	113,9	44	157,9
	8	145,7	28,3	174	139,8	31,7	171,5	133,2	35,5	168,6	125,8	39,7	165,5	117,8	44,3	162,1
	9	150,6	28,5	179,1	144,5	31,9	176,4	137,6	35,7	173,3	130,1	39,9	170	121,8	44,6	166,3
	10	155,6	28,7	184,3	149,3	32,1	181,4	142,2	35,9	178,1	134,4	40,2	174,6	125,8	44,9	170,7
13.2	6	149,1	30,4	179,5	143,6	34,3	177,9	137,3	38,5	175,8	130	43,1	173,1	121,8	48,1	169,9
	7	154,2	30,6	184,8	148,5	34,5	183	141,9	38,8	180,7	134,4	43,4	177,8	126	48,4	174,3
	8	159,4	30,8	190,2	153,5	34,7	188,2	146,7	39	185,7	138,9	43,7	182,6	130,2	48,7	178,9
	9	164,7	31,1	195,7	158,6	35	193,6	151,5	39,3	190,8	143,5	44	187,5	134,5	49	183,5
	10	170,1	31,3	201,3	163,8	35,2	199	156,5	39,5	196,1	148,2	44,3	192,5	138,9	49,4	188,2
14.4	6	157,6	32,2	189,8	150,7	35,8	186,6	143,1	39,9	183	134,7	44,5	179,2	125,5	49,4	175
	7	163,1	32,3	195,5	156	36	192	148,1	40,1	188,2	139,5	44,7	184,1	130	49,6	179,6
	8	168,8	32,4	201,2	161,4	36,1	197,6	153,3	40,3	193,5	144,3	44,8	189,2	134,6	49,8	184,4
	9	174,5	32,6	207,1	166,9	36,3	203,2	158,5	40,4	199	149,3	45	194,3	139,2	50	189,2
	10	180,4	32,7	213,1	172,5	36,4	209	163,9	40,6	204,4	154,4	45,2	199,5	144	50,2	194,2
16.4	6	182,1	37,1	219,2	173,8	41,5	215,3	164,8	46,5	211,3	154,9	52,1	207	144,2	58,3	202,5
	7	188,3	37,2	225,6	179,9	41,6	221,5	170,5	46,6	217,2	160,3	52,3	212,6	149,3	58,5	207,8
	8	194,7	37,4	232,1	186	41,8	227,8	176,4	46,8	223,2	165,8	52,5	218,3	154,4	58,8	213,2
	9	201,3	37,5	238,8	192,2	42	234,2	182,3	47	229,3	171,5	52,7	224,1	159,6	59	218,6
	10	207,9	37,7	245,6	198,6	42,1	240,7	188,4	47,2	235,6	177,2	52,9	230,1	164,9	59,2	224,2
18.4	6	214,3	44	258,3	204,6	49	253,6	194,1	54,8	248,9	182,7	61,3	244	170,5	68,5	239
	7	221,8	44,3	266	211,7	49,3	261	200,9	55,1	255,9	189,1	61,6	250,7	176,5	68,9	245,4
	8	229,4	44,5	273,9	219	49,5	268,6	207,8	55,3	263,1	195,7	61,9	257,6	182,6	69,3	251,9
	9	237,2	44,7	281,9	226,5	49,8	276,3	214,9	55,6	270,5	202,3	62,2	264,6	188,8	69,6	258,5
	10	245,1	44,9	290	234,1	50	284,1	222,1	55,9	278	209,1	62,6	271,7	195,2	70	265,2
20.4	6	246,6	51	297,5	235,4	56,6	292	223,4	63,1	286,5	210,5	70,5	281	196,8	78,8	275,6
	7	255,2	51,3	306,5	243,6	56,9	300,6	231,2	63,5	294,7	217,9	70,9	288,9	203,7	79,2	283
	8	264	51,6	315,6	252,1	57,3	309,3	239,2	63,9	303,1	225,5	71,4	296,9	210,8	79,7	290,6
	9	273,1	51,8	324,9	260,7	57,6	318,3	247,4	64,3	311,7	233,2	71,8	305	218	80,2	298,3
	10	282,3	52,1	334,4	269,5	57,9	327,4	255,8	64,7	320,4	241,1	72,3	313,3	225,4	80,7	306,2
24.4	6	272,4	55,9	328,3	261,3	62,6	323,9	248,9	70	319	235,3	78,3	313,6	220,2	87,4	307,7
	7	281,8	56,3	338	270,3	63	333,3	257,5	70,5	328	243,4	78,8	322,2	227,8	88	315,8
	8	291,4	56,6	348	279,5	63,4	342,9	266,3	71	337,3	251,7	79,4	331	235,6	88,6	324,2
	9	301,2	57	358,2	288,9	63,8	352,7	275,3	71,4	346,7	260,1	79,9	340	243,5	89,1	332,7
	10	311,2	57,3	368,5	298,5	64,2	362,7	284,4	71,9	356,3	268,8	80,4	349,1	251,6	89,7	341,3
26.4	6	298,2	60,9	359	287,2	68,5	355,8	274,5	77	351,5	260	86,2	346,2	243,6	96,1	339,8
	7	308,3	61,3	369,6	297	69	366	283,8	77,5	361,4	268,8	86,8	355,6	251,9	96,8	348,7
	8	318,7	61,7	380,4	307	69,5	376,5	293,4	78	371,4	277,8	87,3	365,2	260,4	97,4	357,8
	9	329,3	62,1	391,4	317,2	70	387,1	303,1	78,6	381,7	287	87,9	375	269	98,1	367
	10	340,1	62,5	402,7	327,6	70,4	398	313	79,1	392,1	296,4	88,5	385	277,8	98,7	376,5

kWf : cooling capacity [kW]

kWe : compressors power input [kW]

kWe : total recovery heating capacity [kW]

T0 : evaporator leaving water temperature [°C]

Inlet/outlet evaporator water thermal difference 5°C

Inlet/outlet condenser water thermal difference 5°C

Technical information manual SIGMA
REF.SIGMA-10230000012_04.08/SIGMA_2011.DOC

COOLING CAPACITY SIGMA 2002 /LE



MODELLO MODEL	T _w [°C]	Temperatura acqua uscita condensatore [°C] Condenser outlet water temperature [°C]									
		30		35		40		45		50	
		kW _f	kW _e	kW _f	kW _e	kW _f	kW _e	kW _f	kW _e	kW _f	kW _e
3.2	0	42	8,7	39,7	9,6	37,3	10,8	34,6	12,1	31,9	13,5
	2,5	46,2	8,7	43,7	9,7	41	10,8	38,2	12,1	35,1	13,6
	5	50,7	8,6	48	9,7	45,1	10,8	42	12,1	38,7	13,6
	7,5	55,5	8,5	52,6	9,5	49,4	10,7	46	12	42,4	13,4
	10	60,6	8,3	57,4	9,3	54	10,4	50,3	11,7	46,4	13,1
4.2	0	50,8	10,2	48	11,5	45	12,9	41,8	14,5	38,4	16,4
	2,5	55,8	10,3	52,8	11,5	49,5	13	46	14,6	42,3	16,5
	5	61,1	10,4	57,8	11,6	54,2	13,1	50,4	14,8	46,4	16,6
	7,5	66,8	10,4	63,2	11,7	59,3	13,2	55,2	14,9	50,8	16,7
	10	72,8	10,5	68,9	11,7	64,7	13,2	60,2	14,9	55,5	16,8
5.2	0	59,4	11,8	56,1	13,2	52,6	14,9	48,8	16,8	44,8	18,9
	2,5	65,2	11,9	61,7	13,3	57,8	15	53,7	16,9	49,3	19,1
	5	71,3	11,9	67,5	13,4	63,4	15,1	59	17	54,2	19,2
	7,5	77,9	12	73,8	13,4	69,3	15,1	64,5	17,1	59,4	19,3
	10	84,9	12	80,4	13,5	75,6	15,2	70,4	17,2	64,8	19,4
6.2	0	68,3	13,8	64,7	15,4	60,7	17,2	56,5	19,2	51,9	21,5
	2,5	75	13,9	71	15,5	66,7	17,3	62,1	19,4	57,2	21,7
	5	82,2	14	77,8	15,6	73,1	17,5	68,2	19,6	62,8	21,9
	7,5	89,7	14,1	85	15,7	80	17,6	74,6	19,7	68,8	22,1
	10	97,8	14,1	92,7	15,8	87,2	17,7	81,4	19,9	75,2	22,2
7.2	0	77,3	15,7	73,2	17,5	68,8	19,5	64,1	21,7	59,1	24,2
	2,5	84,9	15,9	80,4	17,7	75,6	19,7	70,5	22	65,1	24,4
	5	93	16	88,1	17,9	82,9	19,9	77,4	22,2	71,5	24,7
	7,5	101,6	16,2	96,3	18	90,6	20,1	84,6	22,4	78,3	24,9
	10	110,7	16,3	105	18,1	98,9	20,2	92,4	22,5	85,5	25
8.2	0	89,4	18,1	84,5	20,3	79,3	22,7	73,8	25,4	68	28,5
	2,5	98	18,3	92,7	20,5	87,1	22,9	81,1	25,7	74,8	28,8
	5	107,2	18,5	101,4	20,7	95,3	23,1	88,8	25,9	81,9	29,1
	7,5	116,9	18,7	110,7	20,8	104,1	23,4	97,1	26,2	89,6	29,4
	10	127,4	18,8	120,7	21	113,5	23,6	105,8	26,4	97,7	29,6
9.2	0	105,2	21,5	99,4	23,9	93,4	26,7	87	29,9	80,4	33,4
	2,5	115,4	21,8	109,1	24,3	102,5	27,1	95,6	30,3	88,4	33,9
	5	126,4	22,1	119,5	24,6	112,3	27,4	104,8	30,7	96,9	34,3
	7,5	138	22,3	130,6	24,9	122,8	27,8	114,6	31,1	106	34,8
	10	150,5	22,6	142,4	25,2	134	28,2	125,1	31,5	115,7	35,2
10.2	0	121,0	24,9	114,3	27,6	107,4	30,8	100,2	34,3	92,7	38,3
	2,5	132,9	25,3	125,6	28,1	118,0	31,2	110,1	34,9	102,0	38,9
	5	145,6	25,7	137,6	28,5	129,4	31,7	120,8	35,4	111,9	39,6
	7,5	159,1	26,0	150,5	28,9	141,5	32,2	132,2	36,0	122,5	40,2
	10	173,6	26,4	164,2	29,4	154,5	32,8	144,3	36,6	133,8	40,9

kW_f : cooling capacity [kW]

kW_e : compressors power input [kW]

Tev : total recovery heating capacity [kW]

Inlet/outlet evaporator water thermal difference 5°C

Technical information manual SIGMA
REF.SIGMA-10230000012_04.08/SIGMA_2011.DOC

COOLING CAPACITY SIGMA 2002 /LE



MODELLO MODEL	T _w [°C]	Temperatura acqua uscita condensatore [°C] Condenser outlet water temperature [°C]									
		30		35		40		45		50	
		kWf	kWe	kWf	kWe	kWf	kWe	kWf	kWe	kWf	kWe
12.2	0	133,6	27,3	126,9	30,5	119,7	34,1	112,1	38,1	103,9	42,5
	2,5	146,5	27,7	139,2	31,0	131,4	34,7	123,0	38,8	114,0	43,3
	5	160,3	28,2	152,3	31,5	143,8	35,3	134,6	39,4	124,9	44,0
	7,5	175,0	28,7	166,4	32,1	157,1	35,9	147,1	40,1	136,5	44,7
	10	190,7	29,1	181,3	32,6	171,2	36,5	160,4	40,8	148,9	45,5
13.2	0	146,2	29,6	139,5	33,4	132,1	37,5	123,9	41,9	115,1	46,7
	2,5	160,1	30,2	152,8	34,0	144,7	38,1	135,8	42,7	126,1	47,6
	5	175,0	30,7	167,0	34,6	158,2	38,8	148,5	43,4	137,9	48,4
	7,5	190,9	31,3	182,2	35,2	172,6	39,5	162,0	44,2	150,5	49,2
	10	207,9	31,9	198,4	35,8	188,0	40,2	176,5	44,9	164,1	50,1
14.4	0	154,6	31,5	146,4	35,0	137,6	39,0	128,2	43,5	118,2	48,3
	2,5	169,8	31,8	160,8	35,4	151,2	39,5	141,0	43,9	130,2	48,8
	5	185,9	32,1	176,2	35,8	165,8	39,9	154,7	44,4	142,9	49,3
	7,5	203,1	32,3	192,6	36,1	181,3	40,2	169,3	44,7	156,6	49,7
	10	221,4	32,6	210,0	36,3	197,8	40,5	184,8	45,1	171,0	50,1
16.4	0	178,8	36,3	169,0	40,5	158,6	45,4	147,6	50,9	136,0	56,9
	2,5	196,0	36,6	185,4	40,9	174,1	45,9	162,2	51,4	149,5	57,5
	5	214,3	37,0	202,9	41,3	190,6	46,3	177,6	51,9	163,9	58,1
	7,5	233,9	37,3	221,5	41,7	208,2	46,7	194,1	52,4	179,1	58,7
	10	254,7	37,6	241,3	42,0	227,0	47,1	211,6	52,9	195,3	59,2
18.4	0	210,4	43,1	198,8	47,9	186,7	53,5	174,0	59,7	160,7	66,8
	2,5	230,9	43,6	218,3	48,5	205,1	54,2	191,2	60,6	176,7	67,7
	5	252,7	44,2	239,1	49,1	224,7	54,9	209,6	61,4	193,8	68,6
	7,5	276,1	44,7	261,2	49,8	245,6	55,6	229,2	62,2	212,0	69,6
	10	300,9	45,2	284,9	50,4	267,9	56,3	250,1	63,0	231,4	70,5
20.4	0	242,0	49,9	228,7	55,3	214,8	61,5	200,4	68,6	185,4	76,6
	2,5	265,7	50,6	251,2	56,1	236,0	62,5	220,3	69,8	203,9	77,9
	5	291,1	51,3	275,3	57,0	258,8	63,5	241,6	70,9	223,7	79,1
	7,5	318,2	52,0	301,0	57,8	283,0	64,5	264,3	72,0	244,9	80,4
	10	347,1	52,8	328,4	58,7	308,9	65,5	288,6	73,2	267,5	81,7
24.4	0	267,2	54,6	253,8	61,0	239,5	68,2	224,1	76,2	207,8	85,1
	2,5	293,0	55,5	278,4	62,0	262,7	69,4	245,9	77,5	228,0	86,5
	5	320,5	56,4	304,7	63,1	287,6	70,6	269,3	78,9	249,8	88,0
	7,5	350,0	57,3	332,7	64,1	314,1	71,7	294,2	80,2	273,0	89,4
	10	381,4	58,2	362,7	65,2	342,5	73,0	320,8	81,5	297,8	90,9
26.4	0	292,4	59,3	279,0	66,7	264,2	74,9	247,9	83,8	230,1	93,5
	2,5	320,2	60,3	305,6	67,9	289,4	76,3	271,6	85,3	252,2	95,1
	5	350,0	61,4	334,0	69,1	316,4	77,6	296,9	86,8	275,8	96,8
	7,5	381,8	62,6	364,4	70,4	345,2	79,0	324,1	88,4	301,1	98,5
	10	415,8	63,7	396,9	71,7	376,0	80,4	353,1	89,9	328,1	100,1

kWf : cooling capacity [kW]

kWe : compressors power input [kW]

Tev : total recovery heating capacity [kW]

Inlet/outlet evaporator water thermal difference 5°C

Technical information manual SIGMA
REF.SIGMA-1023000012_04.08/SIGMA_2011.DOC

COOLING CAPACITY - SIGMA 2002/LC



MODELLO MODEL	T ₀ [°C]	Temperatura acqua uscita condensatore [°C] Condenser outlet water temperature [°C]																	
		35			40			45			50			55			58		
		kW _f	kW _e	kW _t	kW _f	kW _e	kW _t	kW _f	kW _e	kW _t	kW _f	kW _e	kW _t	kW _f	kW _e	kW _t	kW _f	kW _e	kW _t
12.2	6	137,2	28,2	165,4	131,8	31,4	163,2	125,8	35,1	160,9	119,1	39,1	158,2	111,8	43,5	155,3	103,8	48,3	152,1
	7	142,2	28,3	170,4	136,6	31,5	168,1	130,4	35,2	165,5	123,5	39,2	162,7	116	43,7	159,6	107,7	48,5	156,2
	8	147,2	28,3	175,6	141,5	31,6	173,1	135,1	35,3	170,4	128	39,3	167,3	120,2	43,8	164	111,7	48,6	160,3
	9	152,4	28,4	180,8	146,5	31,7	178,2	139,9	35,4	175,3	132,6	39,4	172	124,6	43,9	168,5	115,8	48,7	164,6
13.2	6	150,2	30,7	180,9	144,9	34,5	179,3	138,7	38,6	177,2	131,6	43	174,6	123,7	47,9	171,5	114,8	53	167,8
	7	155,6	30,8	186,3	150	34,6	184,6	143,6	38,7	182,3	136,4	43,2	179,5	128,2	48	176,2	119,1	53,2	172,3
	8	161	30,9	191,9	155,3	34,7	190	148,8	38,8	187,6	141,3	43,3	184,6	132,8	48,2	181	123,4	53,4	176,8
	9	166,6	31	197,6	160,8	34,8	195,5	154	38,9	192,9	146,3	43,4	189,7	137,6	48,3	185,9	127,9	53,5	181,4
14.4	6	158,8	32,4	191,2	152,1	36	188,1	144,6	40	184,6	136,4	44,4	180,8	127,5	49,2	176,7	117,8	54,4	172,2
	7	164,6	32,4	197,1	157,7	36	193,7	150	40	190	141,6	44,4	186	132,4	49,2	181,6	122,5	54,4	176,9
	8	170,6	32,4	203	163,4	36	199,5	155,6	40	195,6	146,9	44,4	191,3	137,5	49,2	186,7	127,2	54,4	181,6
	9	176,7	32,4	209,1	169,3	36	205,4	161,2	40	201,2	152,3	44,4	196,7	142,6	49,2	191,8	132,1	54,4	186,5
16.4	6	183,4	37,4	220,8	175,3	41,7	217	166,5	46,5	213	156,9	52	208,9	146,5	58	204,5	135,2	64,6	199,8
	7	190	37,4	227,4	181,8	41,7	223,4	172,7	46,5	219,2	162,8	52	214,8	152	58	210	140,4	64,6	205,1
	8	196,8	37,4	234,2	188,3	41,7	230	179	46,5	225,5	168,8	52	220,8	157,7	58	215,7	145,7	64,7	210,4
	9	203,8	37,4	241,2	195	41,7	236,7	185,4	46,5	231,9	174,9	52	226,9	163,5	58	221,5	151,1	64,7	215,8
18.4	6	215,9	44,4	260,2	206,4	49,3	255,6	196,1	54,9	251	185,1	61,2	246,2	173,2	68,2	241,4	160,4	75,9	236,4
	7	223,8	44,4	268,2	214	49,3	263,3	203,4	54,9	258,4	192	61,3	253,3	179,7	68,3	248	166,6	76,1	242,6
	8	231,9	44,5	276,3	221,8	49,4	271,2	210,9	55	265,9	199,1	61,4	260,5	186,5	68,4	254,9	172,9	76,2	249,1
	9	240,1	44,6	284,7	229,7	49,5	279,2	218,5	55,1	273,6	206,4	61,4	267,8	193,3	68,5	261,8	179,3	76,3	255,6
20.4	6	248,4	51,4	299,7	237,4	56,9	294,3	225,7	63,2	288,9	213,2	70,4	283,6	199,9	78,4	278,3	185,6	87,2	272,9
	7	257,5	51,5	309	246,2	57	303,3	234,2	63,4	297,5	221,2	70,6	291,8	207,4	78,6	286	192,8	87,5	280,2
	8	266,9	51,6	318,5	255,3	57,1	312,4	242,8	63,5	306,3	229,4	70,7	300,2	215,2	78,8	294	200,1	87,7	287,8
	9	276,5	51,7	328,2	264,5	57,3	321,8	251,6	63,7	315,3	237,8	70,9	308,8	223,2	79	302,2	207,6	87,9	295,5
24.4	6	274,4	56,4	330,8	263,6	62,9	326,5	251,5	70,2	321,7	238,2	78,2	316,4	223,6	87,1	310,6	207,6	96,7	304,3
	7	284,3	56,5	340,8	273,2	63,1	336,2	260,7	70,4	331,1	247	78,4	325,4	231,9	87,3	319,2	215,4	96,9	312,4
	8	294,5	56,7	351,1	283	63,2	346,2	270,1	70,6	340,7	256	78,7	334,6	240,4	87,6	328	223,5	97,2	320,7
	9	304,8	56,8	361,7	293	63,4	356,4	279,8	70,8	350,5	265,2	78,9	344,1	249,2	87,8	337	231,7	97,5	329,2
26.4	6	300,4	61,4	361,8	289,7	68,9	358,6	277,3	77,1	354,5	263,2	86,1	349,3	247,3	95,7	343	229,6	106,1	335,7
	7	311,1	61,6	372,7	300,1	69,1	369,2	287,3	77,4	364,7	272,7	86,3	359,1	256,4	96	352,4	238,1	106,4	344,5
	8	322	61,8	383,8	310,7	69,3	380	297,5	77,6	375,1	282,5	86,6	369,1	265,6	96,3	362	246,8	106,7	353,6
	9	333,2	61,9	395,1	321,5	69,5	391	308	77,8	385,8	292,5	86,9	379,4	275,1	96,6	371,7	255,8	107,1	362,9
10	344,6	62,1	406,8	332,6	69,7	402,3	318,6	78,1	396,7	302,7	87,1	389,9	284,9	96,9	381,8	265	107,4	372,3	

kW_f : cooling capacity [kW]
 kW_e : compressors power input [kW]
 kW_t : total recovery heating capacity [kW]
 T₀ : evaporator leaving water temperature [°C]

Inlet/outlet evaporator water thermal difference 5°C
 Inlet/outlet condenser water thermal difference 5°C

Technical information manual SIGMA
REF.SIGMA-10230000012_04.08/SIGMA_2011.DOC

HEATING CAPACITY



MODELLO MODEL	T ₀ [°C]	Temperatura acqua ingresso/uscita condensatore [°C] Condenser inlet/outlet water temperature [°C]							
		30/35		35/40		40/45		45/50	
		kWt	kWe	kWt	kWe	kWt	kWe	kWt	kWe
3.2	5	46.3	10.2	45.1	11.4	44.0	12.7	42.8	14.1
	6	47.9	10.2	46.6	11.4	45.4	12.7	44.1	14.2
	7	49.5	10.2	48.1	11.4	46.8	12.7	45.4	14.2
	8	51.1	10.2	49.7	11.4	48.2	12.7	46.8	14.2
	9	52.7	10.2	51.2	11.4	49.7	12.7	48.1	14.1
10	54.4	10.1	52.8	11.3	51.2	12.6	49.6	14.1	
4.2	5	55.9	12.2	54.5	13.7	53.1	15.4	51.8	17.3
	6	57.7	12.2	56.2	13.7	54.8	15.4	53.3	17.2
	7	59.6	12.2	58.0	13.7	56.4	15.4	54.8	17.2
	8	61.5	12.2	59.8	13.7	58.1	15.4	56.4	17.2
	9	63.5	12.2	61.7	13.7	59.9	15.3	58.1	17.2
10	65.5	12.2	63.6	13.6	61.7	15.3	59.8	17.2	
5.2	5	65.1	14.1	63.5	15.8	61.8	17.8	60.1	20.0
	6	67.3	14.0	65.5	15.8	63.7	17.8	61.9	20.0
	7	69.4	14.0	67.6	15.8	65.7	17.7	63.8	20.0
	8	71.7	14.0	69.7	15.8	67.7	17.7	65.7	19.9
	9	74.0	14.0	71.9	15.7	69.8	17.7	67.6	19.9
10	76.4	14.0	74.2	15.7	71.9	17.7	69.6	19.9	
6.2	5	75.2	16.3	73.3	18.2	71.3	20.3	69.4	22.6
	6	77.6	16.3	75.6	18.2	73.5	20.3	71.4	22.6
	7	80.2	16.3	78.0	18.2	75.8	20.3	73.6	22.6
	8	82.8	16.3	80.5	18.2	78.1	20.3	75.7	22.6
	9	85.4	16.3	83.0	18.2	80.6	20.3	78.0	22.6
10	88.2	16.3	85.6	18.2	83.0	20.3	80.3	22.6	
7.2	5	85.2	18.5	83.1	20.6	80.9	22.8	78.6	25.3
	6	88.0	18.5	85.7	20.6	83.4	22.8	80.9	25.3
	7	90.9	18.6	88.5	20.6	85.9	22.9	83.4	25.3
	8	93.9	18.6	91.3	20.6	88.6	22.9	85.8	25.3
	9	96.9	18.6	94.2	20.6	91.3	22.9	88.4	25.4
10	100.0	18.6	97.1	20.7	94.1	22.9	91.1	25.4	
8.2	5	98.5	21.5	96.1	24.0	93.6	26.8	91.2	29.9
	6	101.7	21.5	99.1	24.0	96.5	26.8	93.9	29.9
	7	104.9	21.5	102.2	24.0	99.4	26.8	96.6	29.9
	8	108.3	21.5	105.4	24.0	102.4	26.8	99.5	29.9
	9	111.7	21.5	108.6	24.0	105.5	26.9	102.4	30.0
10	115.3	21.5	112.0	24.0	108.7	26.9	105.3	30.0	
9.2	5	115.9	25.3	113.0	28.2	110.2	31.4	107.5	35.0
	6	119.7	25.4	116.6	28.2	113.6	31.5	110.7	35.0
	7	123.6	25.4	120.3	28.3	117.1	31.5	114.0	35.1
	8	127.6	25.4	124.1	28.3	120.8	31.6	117.4	35.2
	9	131.7	25.5	128.1	28.4	124.5	31.6	120.9	35.2
10	135.9	25.5	132.1	28.4	128.3	31.7	124.5	35.3	
10.2	5	133.3	29.1	130.0	32.4	126.9	36.0	123.9	40.1
	6	137.7	29.2	134.2	32.5	130.8	36.1	127.6	40.2
	7	142.2	29.3	138.5	32.5	134.9	36.2	131.5	40.3
	8	146.9	29.3	142.9	32.6	139.1	36.3	135.4	40.4
	9	151.7	29.4	147.5	32.7	143.4	36.4	139.4	40.5
10	156.6	29.5	152.2	32.8	147.8	36.5	143.6	40.6	

KWt : heating capacity [kW]

kWe : compressors power input [kW]

T0 : evaporator inlet air temperature dry bulb [°C]

Inlet/outlet evaporator water thermal difference 5°C

Technical information manual SIGMA
REF.SIGMA-10230000012_04.08/SIGMA_2011.DOC

HEATING CAPACITY



MODELLO MODEL	T ₀ [°C]	Temperatura acqua ingresso/uscita condensatore [°C] Condenser inlet/outlet water temperature [°C]							
		30/35		35/40		40/45		45/50	
		kW _e	kW _t	kW _e	kW _t	kW _e	kW _t	kW _e	kW _t
12.2	5	148,3	32,2	145,1	35,9	141,9	40,0	138,5	44,4
	6	153,1	32,3	149,7	36,0	146,2	40,1	142,6	44,5
	7	158,0	32,4	154,4	36,1	150,7	40,2	146,8	44,7
	8	163,1	32,5	159,3	36,2	155,3	40,3	151,2	44,8
	9	168,4	32,6	164,3	36,3	160,0	40,5	155,6	45,0
10	173,8	32,7	169,4	36,5	164,9	40,6	160,2	45,1	
13.2	5	163,3	35,3	160,2	39,5	156,8	43,9	153,1	48,7
	6	168,5	35,4	165,2	39,6	161,6	44,1	157,6	48,9
	7	173,8	35,6	170,3	39,7	166,4	44,2	162,2	49,1
	8	179,4	35,7	175,6	39,8	171,5	44,4	166,9	49,3
	9	185,0	35,8	181,0	40,0	176,6	44,5	171,8	49,4
10	190,9	35,9	186,6	40,1	182,0	44,7	176,8	49,6	
14.4	5	170,4	37,1	166,1	41,1	161,7	45,7	157,2	50,6
	6	176,0	37,1	171,4	41,2	166,7	45,7	161,9	50,6
	7	181,8	37,1	176,9	41,2	171,9	45,7	166,7	50,7
	8	187,7	37,2	182,5	41,3	177,2	45,8	171,7	50,7
	9	193,8	37,2	188,3	41,3	182,7	45,8	176,8	50,7
10	200,0	37,2	194,3	41,3	188,3	45,8	182,1	50,7	
16.4	5	197,0	43,0	192,1	48,0	187,2	53,6	182,3	59,7
	6	203,4	43,0	198,1	48,0	192,9	53,6	187,7	59,8
	7	209,9	43,0	204,3	48,1	198,8	53,7	193,2	59,8
	8	216,6	43,1	210,7	48,1	204,8	53,7	198,9	59,9
	9	223,5	43,1	217,3	48,1	211,0	53,7	204,7	59,9
10	230,6	43,1	224,0	48,1	217,4	53,7	210,7	59,9	
18.4	5	231,8	50,6	226,1	56,4	220,5	62,8	215,1	69,9
	6	239,4	50,7	233,3	56,5	227,3	62,9	221,5	70,1
	7	247,2	50,8	240,7	56,6	234,3	63,0	228,1	70,2
	8	255,2	50,9	248,3	56,7	241,5	63,2	234,8	70,3
	9	263,4	51,0	256,1	56,8	248,9	63,3	241,8	70,5
10	271,9	51,0	264,2	56,8	256,5	63,4	249,0	70,6	
20.4	5	266,6	58,2	260,0	64,7	253,8	72,0	247,8	80,2
	6	275,4	58,4	268,4	64,9	261,7	72,2	255,3	80,4
	7	284,4	58,5	277,0	65,1	269,8	72,4	262,9	80,6
	8	293,8	58,7	285,8	65,2	278,2	72,6	270,8	80,8
	9	303,4	58,9	295,0	65,4	286,8	72,8	278,9	81,0
10	313,2	59,0	304,3	65,6	295,7	73,0	287,3	81,2	
24.4	5	296,6	64,5	290,2	71,8	283,7	79,9	277,0	88,8
	6	306,2	64,6	299,4	72,0	292,4	80,2	285,2	89,1
	7	316,1	64,8	308,8	72,3	301,3	80,4	293,6	89,4
	8	326,2	65,0	318,5	72,5	310,5	80,7	302,3	89,7
	9	336,7	65,2	328,5	72,7	320,0	80,9	311,3	89,9
10	347,5	65,4	338,8	72,9	329,8	81,2	320,5	90,2	
26.4	5	326,6	70,7	320,4	78,9	313,6	87,9	306,2	97,5
	6	337,0	70,9	330,4	79,2	323,1	88,2	315,2	97,8
	7	347,7	71,1	340,6	79,4	332,9	88,5	324,4	98,2
	8	358,7	71,3	351,2	79,7	342,9	88,8	333,9	98,5
	9	370,1	71,6	362,1	80,0	353,3	89,1	343,6	98,8
10	381,8	71,8	373,3	80,2	363,9	89,3	353,7	99,2	

KWt : heating capacity [kW]

kWe : compressors power input [kW]

T0 : evaporator inlet air temperature dry bulb [°C]

Inlet/outlet evaporator water thermal difference 5°C

Technical information manual SIGMA

REF.SIGMA-10230000012_04.08/SIGMA_2011.DOC

HEATING CAPACITY SIGMA 2002 HP/LE



MODELLO MODEL	T ₀ [°C]	Temperatura acqua ingresso/uscita condensatore [°C] Condenser inlet/outlet water temperature [°C]											
		35		40		45		50		55		60	
		KW _t	KW _e	KW _t	KW _e	KW _t	KW _e	KW _t	KW _e	KW _t	KW _e	KW _t	KW _e
3.2	6	49,5	8,9	48,2	9,9	47,0	11,0	45,7	12,3	44,5	13,7	43,2	15,3
	7	51,1	8,9	49,8	9,9	48,5	11,0	47,2	12,3	45,8	13,7	44,4	15,3
	8	52,9	8,9	51,5	9,9	50,1	11,0	48,7	12,3	47,2	13,7	45,7	15,3
	9	54,6	8,9	53,2	9,9	51,7	11,0	50,2	12,3	48,6	13,7	47,0	15,2
	10	56,4	8,8	54,9	9,8	53,3	11,0	51,7	12,2	50,1	13,6	48,4	15,2
4.2	6	59,6	10,5	58,2	11,8	56,7	13,2	55,2	14,8	53,7	16,7	52,2	18,7
	7	61,6	10,5	60,1	11,8	58,5	13,2	56,9	14,8	55,3	16,7	53,7	18,7
	8	63,7	10,5	62,0	11,8	60,3	13,2	58,7	14,8	56,9	16,6	55,2	18,7
	9	65,8	10,5	64,0	11,8	62,2	13,2	60,4	14,8	58,6	16,6	56,8	18,6
	10	67,9	10,5	66,1	11,7	64,2	13,2	62,3	14,8	60,4	16,6	58,4	18,6
5.2	6	69,5	12,1	67,8	13,6	66,0	15,2	64,3	17,1	62,5	19,3	60,6	21,7
	7	71,8	12,1	70,0	13,6	68,1	15,2	66,3	17,1	64,3	19,3	62,4	21,7
	8	74,2	12,1	72,3	13,5	70,3	15,2	68,3	17,1	66,3	19,3	64,2	21,6
	9	76,6	12,1	74,6	13,5	72,5	15,2	70,4	17,1	68,3	19,2	66,1	21,6
	10	79,2	12,1	77,0	13,5	74,8	15,2	72,6	17,1	70,3	19,2	68,0	21,6
6.2	6	80,2	14,2	78,2	15,8	76,2	17,6	74,2	19,6	72,1	21,9	69,9	24,4
	7	82,9	14,2	80,8	15,8	78,7	17,6	76,5	19,6	74,2	21,9	72,0	24,4
	8	85,7	14,2	83,4	15,8	81,2	17,6	78,9	19,6	76,5	21,9	74,0	24,4
	9	88,5	14,2	86,2	15,8	83,8	17,6	81,3	19,6	78,8	21,9	76,2	24,4
	10	91,4	14,2	88,9	15,8	86,4	17,6	83,8	19,6	81,1	21,9	78,4	24,4
7.2	6	90,9	16,2	88,7	18,0	86,4	20,0	84,1	22,2	81,7	24,5	79,2	27,2
	7	94,0	16,2	91,6	18,0	89,2	20,0	86,7	22,2	84,1	24,6	81,5	27,2
	8	97,1	16,2	94,6	18,0	92,1	20,0	89,4	22,2	86,7	24,6	83,9	27,2
	9	100,3	16,2	97,7	18,0	95,0	20,0	92,2	22,2	89,3	24,6	86,3	27,2
	10	103,6	16,2	100,9	18,0	98,0	20,0	95,1	22,2	92,0	24,6	88,8	27,2
8.2	6	105,1	18,7	102,5	20,8	99,9	23,2	97,2	25,9	94,6	28,9	92,0	32,2
	7	108,5	18,7	105,8	20,8	103,0	23,3	100,2	26,0	97,5	29,0	94,7	32,2
	8	112,1	18,7	109,2	20,8	106,2	23,3	103,3	26,0	100,3	29,0	97,4	32,3
	9	115,7	18,7	112,7	20,8	109,6	23,3	106,5	26,0	103,3	29,0	100,1	32,3
	10	119,5	18,7	116,3	20,8	113,0	23,3	109,7	26,0	106,4	29,0	103,0	32,3
9.2	6	123,8	22,1	120,6	24,6	117,5	27,3	114,5	30,5	111,6	33,9	108,8	37,7
	7	127,9	22,2	124,6	24,6	121,3	27,4	118,1	30,5	115,0	34,0	111,9	37,8
	8	132,2	22,2	128,6	24,6	125,2	27,4	121,8	30,6	118,4	34,1	115,1	37,9
	9	136,5	22,2	132,8	24,7	129,1	27,5	125,5	30,6	122,0	34,1	118,4	38,0
	10	141,0	22,3	137,1	24,7	133,2	27,5	129,4	30,7	125,6	34,2	121,9	38,0
10.2	6	142,5	25,6	138,8	28,3	135,2	31,4	131,8	35,0	128,6	38,9	125,5	43,3
	7	147,3	25,6	143,4	28,4	139,6	31,5	136,0	35,1	132,5	39,0	129,1	43,4
	8	152,2	25,7	148,1	28,4	144,1	31,6	140,2	35,2	136,5	39,1	132,9	43,5
	9	157,3	25,8	153,0	28,5	148,7	31,7	144,6	35,3	140,6	39,2	136,8	43,6
	10	162,6	25,8	158,0	28,6	153,5	31,8	149,1	35,3	144,9	39,3	140,7	43,8

KW_t : heating capacity [kW]

kW_e : compressors power input [kW]

T₀ : evaporator inlet air temperature dry bulb [°C]

Inlet/outlet evaporator water thermal difference 5°C

Technical information manual SIGMA

REF.SIGMA-1023000012_04.08/SIGMA_2011.DOC

HEATING CAPACITY SIGMA 2002 HP/LE



MODELLO MODEL	T ₀ [°C]	Temperatura acqua ingresso/uscita condensatore [°C] Condenser inlet/outlet water temperature [°C]											
		35		40		45		50		55		60	
		kWt	kWe	kWt	kWe	kWt	kWe	kWt	kWe	kWt	kWe	kWt	kWe
12.2	6	157,4	28,1	154,1	31,3	150,7	34,9	147,3	38,8	143,7	43,2	140,0	47,9
	7	162,6	28,1	159,1	31,4	155,5	35,0	151,8	39,0	148,0	43,3	144,1	48,0
	8	168,0	28,2	164,3	31,5	160,4	35,1	156,5	39,1	152,4	43,4	148,2	48,2
	9	173,5	28,3	169,6	31,6	165,5	35,2	161,3	39,2	157,0	43,6	152,5	48,3
	10	179,2	28,4	175,0	31,6	170,7	35,3	166,3	39,3	161,7	43,7	156,9	48,5
13.2	6	172,3	30,6	169,4	34,3	166,2	38,3	162,7	42,7	158,8	47,4	154,6	52,5
	7	177,9	30,7	174,8	34,4	171,4	38,4	167,6	42,8	163,5	47,6	159,0	52,7
	8	183,7	30,7	180,4	34,5	176,8	38,6	172,7	43,0	168,3	47,8	163,5	52,9
	9	189,6	30,8	186,2	34,6	182,3	38,7	178,0	43,1	173,3	47,9	168,2	53,1
	10	195,8	30,9	192,1	34,7	188,0	38,8	183,4	43,3	178,4	48,1	173,0	53,2
14.4	6	181,9	32,4	177,4	35,9	172,8	39,9	168,2	44,3	163,4	49,1	158,4	54,3
	7	187,9	32,4	183,2	36,0	178,4	40,0	173,4	44,3	168,3	49,1	163,0	54,3
	8	194,2	32,4	189,2	36,0	184,1	40,0	178,8	44,4	173,4	49,2	167,7	54,4
	9	200,6	32,4	195,4	36,0	190,0	40,0	184,4	44,4	178,6	49,2	172,6	54,4
	10	207,2	32,4	201,7	36,0	196,0	40,0	190,1	44,4	184,0	49,2	177,6	54,4
16.4	6	210,1	37,4	204,9	41,6	199,7	46,5	194,5	51,9	189,3	57,9	184,1	64,4
	7	217,0	37,4	211,5	41,7	206,0	46,5	200,5	51,9	194,9	57,9	189,3	64,5
	8	224,2	37,4	218,3	41,7	212,5	46,5	206,6	51,9	200,7	58,0	194,7	64,6
	9	231,5	37,4	225,3	41,7	219,1	46,5	212,9	52,0	206,6	58,0	200,3	64,6
	10	239,0	37,4	232,5	41,7	226,0	46,5	219,4	52,0	212,7	58,0	205,9	64,6
18.4	6	247,5	44,3	241,2	49,1	235,1	54,7	229,1	60,9	223,2	67,9	217,5	75,5
	7	255,8	44,3	249,1	49,2	242,6	54,8	236,2	61,0	229,9	68,0	223,8	75,6
	8	264,3	44,4	257,3	49,3	250,3	54,9	243,5	61,1	236,8	68,1	230,3	75,8
	9	273,0	44,5	265,6	49,4	258,3	54,9	251,1	61,2	243,9	68,2	236,9	75,9
	10	282,0	44,5	274,2	49,4	266,5	55,0	258,8	61,3	251,2	68,4	243,7	76,1
20.4	6	284,9	51,2	277,5	56,6	270,4	62,9	263,6	69,9	257,1	77,8	251,0	86,6
	7	294,6	51,3	286,7	56,8	279,2	63,0	271,9	70,1	264,9	78,1	258,3	86,8
	8	304,5	51,4	296,2	56,9	288,2	63,2	280,4	70,3	273,0	78,3	265,8	87,0
	9	314,6	51,5	305,9	57,0	297,4	63,4	289,2	70,5	281,2	78,5	273,5	87,3
	10	325,1	51,7	315,9	57,2	307,0	63,5	298,3	70,7	289,8	78,7	281,5	87,5
24.4	6	314,7	56,1	308,2	62,6	301,4	69,7	294,5	77,7	287,4	86,3	280,1	95,8
	7	325,2	56,3	318,2	62,7	311,0	69,9	303,6	77,9	296,0	86,6	288,1	96,1
	8	335,9	56,5	328,5	62,9	320,9	70,2	313,0	78,1	304,8	86,9	296,4	96,4
	9	347,0	56,6	339,1	63,1	331,0	70,4	322,6	78,4	313,9	87,2	305,0	96,7
	10	358,3	56,8	350,0	63,3	341,5	70,6	332,5	78,6	323,3	87,4	313,8	97,0
26.4	6	344,5	61,1	338,8	68,5	332,4	76,6	325,4	85,4	317,6	94,8	309,2	105,0
	7	355,8	61,3	349,7	68,7	342,8	76,9	335,3	85,7	327,0	95,2	318,0	105,4
	8	367,4	61,5	360,8	69,0	353,5	77,1	345,5	86,0	336,7	95,5	327,1	105,7
	9	379,3	61,7	372,3	69,2	364,6	77,4	356,0	86,3	346,6	95,8	336,4	106,1
	10	391,5	61,9	384,2	69,4	375,9	77,6	366,8	86,5	356,8	96,2	346,0	106,5

KWt : heating capacity [kW]

kWe : compressors power input [kW]

T₀ : evaporator inlet air temperature dry bulb [°C]

Inlet/outlet evaporator water thermal difference 5°C

Technical information manual SIGMA

REF.SIGMA-10230000012_04.08/SIGMA_2011.DOC

HEATING CAPACITY SIGMA 2002 HP/LC



MODELLO MODEL	T _{ev} [°C]	Temperatura acqua ingresso/uscita condensatore [°C] Condenser inlet/outlet water temperature [°C]							
		30		35		40		45	
		kW _i	kW _e	kW _i	kW _e	kW _i	kW _e	kW _i	kW _e
3.2	-15	28,0	8,7	27,6	9,6	27,1	10,7	26,8	11,9
	-10	34,3	9,5	33,6	10,6	33,0	11,8	32,4	13,1
	-7	38,3	9,9	37,5	11,0	36,7	12,3	35,9	13,6
	0	48,7	10,2	47,4	11,4	46,1	12,7	44,7	14,2
	2,5	52,7	10,2	51,2	11,4	49,7	12,7	48,1	14,1
	5	57,0	10,1	55,3	11,2	53,5	12,5	51,7	14,0
	7,5	61,5	9,8	59,6	11,0	57,5	12,3	55,4	13,7
4.2	-15	35,9	12,1	35,6	13,6	35,3	15,2	35,1	17,1
	-10	42,4	12,2	41,7	13,7	41,1	15,3	40,5	17,2
	-7	46,8	12,2	45,9	13,7	45,0	15,4	44,2	17,2
	0	58,6	12,2	57,1	13,7	55,6	15,4	54,0	17,2
	2,5	63,5	12,2	61,7	13,7	59,9	15,3	58,1	17,2
	5	68,7	12,1	66,6	13,6	64,5	15,3	62,4	17,2
	7,5	74,2	12,1	71,9	13,6	69,5	15,3	67,0	17,1
5.2	-15	41,7	14,1	41,2	15,8	40,8	17,8	40,5	20,0
	-10	49,3	14,1	48,4	15,8	47,6	17,8	46,8	20,0
	-7	54,4	14,1	53,3	15,8	52,2	17,8	51,1	20,0
	0	68,3	14,0	66,5	15,8	64,7	17,8	62,8	20,0
	2,5	74,0	14,0	71,9	15,7	69,8	17,7	67,6	19,9
	5	80,0	14,0	77,6	15,7	75,2	17,7	72,7	19,9
	7,5	86,4	13,9	83,7	15,6	81,0	17,6	78,1	19,8
6.2	-15	48,0	16,1	47,7	18,0	47,7	20,1	47,9	22,4
	-10	56,8	16,2	55,9	18,1	55,1	20,2	54,5	22,5
	-7	62,8	16,2	61,5	18,1	60,3	20,2	59,2	22,6
	0	78,9	16,3	76,8	18,2	74,7	20,3	72,5	22,6
	2,5	85,4	16,3	83,0	18,2	80,6	20,3	78,0	22,6
	5	92,4	16,3	89,7	18,2	86,9	20,3	83,9	22,6
	7,5	99,9	16,2	96,8	18,1	93,6	20,2	90,3	22,6
7.2	-15	54,2	18,2	54,2	20,2	54,5	22,4	55,3	24,8
	-10	64,3	18,3	63,4	20,3	62,7	22,6	62,1	25,0
	-7	71,1	18,4	69,8	20,4	68,5	22,7	67,3	25,1
	0	89,5	18,6	87,1	20,6	84,6	22,9	82,1	25,3
	2,5	96,9	18,6	94,2	20,6	91,3	22,9	88,4	25,4
	5	104,8	18,6	101,7	20,7	98,5	22,9	95,2	25,4
	7,5	113,3	18,6	109,8	20,6	106,2	22,9	102,4	25,4
8.2	-15	63,5	21,2	62,6	23,5	61,5	26,2	60,2	29,0
	-10	74,9	21,3	73,6	23,8	72,1	26,5	70,7	29,4
	-7	82,6	21,4	80,9	23,9	79,2	26,6	77,5	29,6
	0	103,3	21,5	100,6	24,0	97,9	26,8	95,2	29,9
	2,5	111,7	21,5	108,6	24,0	105,5	26,9	102,4	30,0
	5	120,8	21,5	117,2	24,0	113,6	26,9	110,0	30,0
	7,5	130,4	21,5	126,4	24,0	122,3	26,9	118,1	30,0

KWt : heating capacity [kW]

kWe : compressors power input [kW]

Tev : total recovery heating capacity [kW]

Inlet/outlet evaporator water thermal difference 5°C

Technical information manual SIGMA

REF.SIGMA-10230000012_04.08/SIGMA_2011.DOC

HEATING CAPACITY SIGMA 2002 HP/LC



MODELLO MODEL	T _w [°C]	Temperatura acqua ingresso/uscita condensatore [°C] Condenser inlet/outlet water temperature [°C]							
		30		35		40		45	
		kW _t	kW _e	kW _t	kW _e	kW _t	kW _e	kW _t	kW _e
9.2	-15	74,5	24,7	73,6	27,5	72,7	30,5	71,9	33,9
	-10	87,9	24,9	86,4	27,7	85,0	30,9	83,6	34,3
	-7	97,0	25,1	95,0	27,9	93,2	31,1	91,4	34,6
	0	121,6	25,4	118,5	28,3	115,4	31,5	112,4	35,1
	2,5	131,7	25,5	128,1	28,4	124,5	31,6	120,9	35,2
	5	142,5	25,6	138,4	28,5	134,2	31,8	130,0	35,4
	7,5	154,1	25,7	149,4	28,6	144,6	31,9	139,8	35,5
10.2	-15	85,5	28,2	84,6	31,4	83,9	34,9	83,5	38,8
	-10	100,9	28,5	99,2	31,7	97,8	35,3	96,6	39,2
	-7	111,3	28,7	109,2	31,9	107,2	35,5	105,4	39,5
	0	139,9	29,2	136,3	32,5	132,8	36,2	129,5	40,2
	2,5	151,7	29,4	147,5	32,7	143,4	36,4	139,4	40,5
	5	164,3	29,6	159,5	32,9	154,8	36,7	150,1	40,8
	7,5	177,8	29,8	172,4	33,2	167,0	36,9	161,6	41,1
12.2	-15	96,0	31,0	95,1	34,5	94,4	38,3	93,8	42,4
	-10	112,8	31,5	111,3	35,0	109,8	38,9	108,3	43,2
	-7	124,3	31,7	122,2	35,3	120,2	39,3	118,1	43,6
	0	155,5	32,4	152,0	36,1	148,4	40,2	144,7	44,6
	2,5	168,4	32,6	164,3	36,3	160,0	40,5	155,6	45,0
	5	182,1	32,8	177,4	36,6	172,5	40,8	167,4	45,3
	7,5	196,9	33,1	191,5	36,9	185,9	41,1	180,0	45,7
13.2	-15	106,5	33,8	105,7	37,6	104,9	41,7	104,0	46,0
	-10	124,8	34,4	123,4	38,3	121,7	42,6	120,0	47,1
	-7	137,3	34,7	135,3	38,7	133,1	43,1	130,7	47,7
	0	171,2	35,5	167,7	39,7	164,0	44,2	159,9	49,0
	2,5	185,0	35,8	181,0	40,0	176,6	44,5	171,8	49,4
	5	200,0	36,1	195,3	40,3	190,2	44,9	184,7	49,8
	7,5	216,0	36,4	210,7	40,6	204,8	45,3	198,5	50,2
14.4	-15	108,5	36,4	108,3	40,4	109,0	44,8	110,6	49,6
	-10	128,7	36,6	126,8	40,7	125,3	45,1	124,3	50,0
	-7	142,3	36,8	139,5	40,9	136,9	45,3	134,5	50,2
	0	178,9	37,1	174,2	41,2	169,3	45,7	164,3	50,6
	2,5	193,8	37,2	188,3	41,3	182,7	45,8	176,8	50,7
	5	209,7	37,2	203,5	41,3	197,0	45,8	190,3	50,7
	7,5	226,7	37,2	219,6	41,3	212,3	45,8	204,8	50,7
16.4	-15	127,0	42,3	125,2	47,1	123,0	52,3	120,3	58,0
	-10	149,8	42,7	147,1	47,6	144,3	53,0	141,3	58,9
	-7	165,2	42,8	161,8	47,8	158,4	53,3	154,9	59,2
	0	206,6	43,0	201,2	48,1	195,8	53,6	190,5	59,8
	2,5	223,5	43,1	217,3	48,1	211,0	53,7	204,7	59,9
	5	241,6	43,1	234,5	48,1	227,3	53,7	219,9	60,0
	7,5	260,9	43,0	252,8	48,1	244,6	53,7	236,1	60,0

KW_t : heating capacity [kW]

kW_e : compressors power input [kW]

Tev : total recovery heating capacity [kW]

Inlet/outlet evaporator water thermal difference 5°C

Technical information manual SIGMA
REF.SIGMA-10230000012_04.08/SIGMA_2011.DOC

HEATING CAPACITY SIGMA 2002 HP/LC



MODELLO MODEL	T _w [°C]	Temperatura acqua ingresso/uscita condensatore [°C] Condenser inlet/outlet water temperature [°C]							
		30		35		40		45	
		KW _t	KW _e	KW _t	KW _e	KW _t	KW _e	KW _t	KW _e
18.4	-15	149,0	49,4	147,2	54,9	145,4	61,0	143,7	67,8
	-10	175,8	49,9	172,8	55,5	169,9	61,7	167,2	68,6
	-7	193,9	50,2	190,1	55,8	186,4	62,1	182,9	69,1
	0	243,2	50,8	236,9	56,5	230,8	63,0	224,8	70,1
	2,5	263,4	51,0	256,1	56,8	248,9	63,3	241,8	70,5
	5	285,1	51,1	276,7	57,0	268,4	63,5	260,1	70,8
	7,5	308,3	51,3	298,8	57,2	289,3	63,8	279,7	71,1
20.4	-15	171,0	56,5	169,2	62,8	167,9	69,8	167,1	77,5
	-10	201,7	57,1	198,4	63,4	195,6	70,5	193,2	78,4
	-7	222,7	57,5	218,3	63,8	214,4	71,0	210,9	79,0
	0	279,9	58,5	272,6	65,0	265,7	72,3	259,1	80,5
	2,5	303,4	58,9	295,0	65,4	286,8	72,8	278,9	81,0
	5	328,6	59,2	319,0	65,9	309,5	73,3	300,3	81,6
	7,5	355,7	59,6	344,7	66,3	333,9	73,8	323,2	82,1
24.4	-15	191,9	62,0	190,3	69,0	188,8	76,6	187,5	84,8
	-10	225,7	62,9	222,6	70,0	219,5	77,8	216,6	86,3
	-7	248,6	63,4	244,5	70,7	240,3	78,6	236,2	87,2
	0	311,1	64,7	304,1	72,1	296,8	80,3	289,4	89,2
	2,5	336,7	65,2	328,5	72,7	320,0	80,9	311,3	89,9
	5	364,3	65,7	354,8	73,2	345,0	81,5	334,8	90,6
	7,5	393,8	66,2	383,0	73,8	371,8	82,2	360,1	91,3
26.4	-15	212,9	67,6	211,4	75,2	209,8	83,3	207,9	92,0
	-10	249,6	68,8	246,7	76,6	243,5	85,1	240,0	94,2
	-7	274,6	69,4	270,6	77,5	266,3	86,1	261,5	95,4
	0	342,3	71,0	335,5	79,3	328,0	88,3	319,7	98,0
	2,5	370,1	71,6	362,1	80,0	353,3	89,1	343,6	98,8
	5	399,9	72,1	390,7	80,6	380,5	89,8	369,3	99,7
	7,5	432,0	72,7	421,4	81,3	409,7	90,5	396,9	100,5

KW_t : heating capacity [kW]

kW_e : compressors power input [kW]

Tev : total recovery heating capacity [kW]

Inlet/outlet evaporator water thermal difference 5°C

Technical information manual SIGMA

REF.SIGMA-10230000012_04.08/SIGMA_2011.DOC

TOTAL HEAT RECOVERY CAPACITY



MODELLO MODEL	T ₀ [°C]	Temperatura acqua ingresso/uscita condensatore [°C] Condenser inlet/outlet water temperature [°C]											
		30/35			35/40			40/45			45/50		
		kW _f	kW _e	kW _t	kW _f	kW _e	kW _t	kW _f	kW _e	kW _t	kW _f	kW _e	kW _t
3.2	6	40,8	9,9	50,7	38,3	11,0	49,3	35,6	12,3	47,9	32,8	13,7	46,5
	7	42,5	9,9	52,3	39,9	11,0	50,9	37,1	12,3	49,4	34,2	13,7	47,9
	10	47,8	9,7	57,5	45,0	10,9	55,8	41,9	12,1	54,1	38,7	13,5	52,3
4.2	6	49,3	11,8	61,0	46,2	13,2	59,4	42,9	14,8	57,8	39,5	16,7	56,1
	7	51,2	11,8	63,0	48,1	13,2	61,3	44,7	14,8	59,5	41,1	16,6	57,8
	10	57,6	11,7	69,3	54,1	13,2	67,2	50,4	14,8	65,2	46,4	16,6	63,0
5.2	6	57,6	13,6	71,1	54,0	15,2	69,2	50,1	17,1	67,3	46,0	19,3	65,3
	7	59,9	13,5	73,4	56,2	15,2	71,4	52,2	17,1	69,4	48,0	19,2	67,3
	10	67,2	13,5	80,7	63,2	15,1	78,4	58,9	17,0	75,9	54,3	19,2	73,5
6.2	6	66,3	15,8	82,1	62,3	17,6	79,9	58,0	19,6	77,7	53,4	21,9	75,3
	7	69,0	15,8	84,8	64,9	17,6	82,5	60,4	19,6	80,1	55,7	21,9	77,6
	10	77,5	15,8	93,2	72,9	17,6	90,5	68,1	19,6	87,7	62,9	21,9	84,8
7.2	6	75,1	18,0	93,1	70,6	20,0	90,6	65,9	22,2	88,0	60,8	24,6	85,4
	7	78,1	18,0	96,1	73,5	20,0	93,5	68,6	22,2	90,8	63,4	24,6	88,0
	10	87,7	18,0	105,8	82,7	20,0	102,7	77,3	22,2	99,5	71,6	24,6	96,2
8.2	6	86,6	20,8	107,5	81,4	23,3	104,6	75,8	26,0	101,8	69,9	29,0	98,9
	7	90,1	20,8	110,9	84,6	23,3	107,9	78,9	26,0	104,9	72,8	29,0	101,8
	10	101,0	20,8	121,8	95,0	23,3	118,3	88,7	26,0	114,7	82,0	29,0	111,1
9.2	6	102,0	24,6	126,6	95,8	27,4	123,2	89,4	30,5	119,9	82,7	34,0	116,7
	7	106,0	24,7	130,7	99,7	27,4	127,1	93,0	30,6	123,6	86,1	34,1	120,2
	10	119,0	24,8	143,8	112,0	27,6	139,6	104,7	30,7	135,4	97,0	34,3	131,3
10.2	6	117,3	28,4	145,7	110,3	31,6	141,8	103,0	35,1	138,1	95,4	39,1	134,5
	7	122,0	28,5	150,5	114,7	31,6	146,4	107,2	35,2	142,4	99,4	39,2	138,5
	10	137,1	28,7	165,8	129,0	31,9	160,9	120,7	35,5	156,2	112,0	39,5	151,5
12.2	6	130,2	31,4	161,7	122,9	35,0	157,9	115,1	39,0	154,1	106,8	43,4	150,2
	7	135,4	31,5	166,9	127,8	35,1	162,9	119,7	39,1	158,9	111,2	43,5	154,7
	10	151,7	31,8	183,5	143,4	35,4	178,8	134,5	39,5	174,0	125,0	43,9	168,9
13.2	6	143,2	34,4	177,6	135,6	38,5	174,1	127,3	42,9	170,2	118,2	47,7	165,9
	7	148,7	34,5	183,3	140,9	38,6	179,5	132,3	43,1	175,4	123,0	47,8	170,8
	10	166,4	34,9	201,3	157,8	39,0	196,8	148,3	43,5	191,8	138,1	48,3	186,4
14.4	6	150,2	36,0	186,2	141,3	40,0	181,2	131,7	44,4	176,1	121,6	49,2	170,8
	7	156,3	36,0	192,3	147,0	40,0	187,0	137,2	44,4	181,6	126,8	49,2	176,0
	10	175,5	36,0	211,5	165,3	40,0	205,4	154,5	44,4	199,0	143,1	49,2	192,4
16.4	6	173,3	41,7	214,9	162,7	46,5	209,2	151,6	51,9	203,5	139,8	57,9	197,8
	7	180,1	41,7	221,8	169,3	46,5	215,8	157,8	52,0	209,7	145,7	58,0	203,6
	10	202,0	41,7	243,7	190,1	46,5	236,6	177,5	52,0	229,4	164,1	58,0	222,1
18.4	6	203,9	49,2	253,2	191,6	54,8	246,4	178,8	61,1	239,8	165,3	68,0	233,4
	7	212,1	49,3	261,4	199,4	54,9	254,3	186,1	61,2	247,3	172,2	68,2	240,4
	10	238,1	49,5	287,6	224,1	55,2	279,2	209,4	61,5	270,9	194,0	68,5	262,6
20.4	6	234,6	56,8	291,4	220,5	63,1	283,6	205,9	70,2	276,1	190,8	78,2	268,9
	7	244,0	57,0	301,0	229,5	63,3	292,8	214,4	70,4	284,8	198,7	78,4	277,1
	10	274,1	57,4	331,5	258,0	63,8	321,8	241,3	71,0	312,3	224,0	79,0	303,0
24.4	6	260,5	62,8	323,3	245,8	70,1	315,9	230,2	78,0	308,2	213,6	86,7	300,4
	7	270,8	63,0	333,8	255,6	70,3	325,9	239,5	78,3	317,8	222,3	87,0	309,3
	10	303,5	63,6	367,0	286,8	70,9	357,7	269,0	79,0	348,0	250,1	87,8	337,9
26.4	6	286,4	68,9	355,2	271,2	77	348,2	254,5	85,8	340,4	236,5	95,3	331,8
	7	297,5	69,1	366,5	281,8	77,2	359	264,6	86,1	350,7	245,9	95,7	341,6
	10	332,8	69,7	402,5	315,6	78	393,6	296,7	87	383,6	276,1	96,6	372,8

kW_f : cooling capacity [kW]

kW_e : compressors power input [kW]

kW_t : total recovery heating capacity [kW]

T₀ : evaporator leaving water temperature [°C]

Inlet/outlet evaporator water thermal difference 5°C

Technical information manual SIGMA

REF.SIGMA-10230000012_04.08/SIGMA_2011.DOC

Inlet/outlet condenser water thermal difference 5°C

Technical information manual SIGMA
 REF.SIGMA-10230000012_04.08/SIGMA_2011.DOC

FOULING FACTOR CORRECTIONS

Fattori di incrostazione <i>Fouling factors (m°C/W)</i>	Evaporatore <i>Evaporator</i>		Recuperatore <i>Recovery condenser</i>	
	f1	fp1	f2	fp2
0 Scambiatore pulito <i>Clean exchanger</i>	1	1	1	1
0,44 x 10 ⁻⁴	0,98	0,99	0,99	1,03
0,88 x 10 ⁻⁴	0,96	0,99	0,98	1,04
1,76 x 10 ⁻⁴	0,93	0,98	0,95	1,06

f1-f2 : capacity correction factors

fp1-fp2 : compressor power input correction factor

Unit performances reported in the tables are given for the condition of clean exchanger (fouling factor = 1),
 For different fouling factor values, unit performances should be corrected with the correction factors shown above.

Technical information manual SIGMA

REF.SIGMA-10230000012_04.08/SIGMA_2011.DOC

ETHYLENE GLYCOL MIXTURES

ETHYLENE GLYCOL MIXTURES

The use of ethylene glycol mixtures is intended to prevent freezing in chiller heat exchangers. The use of low freezing point mixtures causes a modification in the main thermodynamic properties of the units. The major parameters affected by the use of glycol mixtures are the following:

- cooling capacity
- power input
- mixture flow
- pressure drop

In the table below are reported correction factors referred to the most common ethylene glycol mixtures.

Perc. di glicole in peso [%]	10	20	30	40	50	Ethylene glycol percent by weight [%]
Temp. di congelamento [°C]	-3,60	-8,70	-15,30	-23,50	-35,60	Freezing point [°C]
Coeff. correttivo resa frigor.	0,986	0,980	0,973	0,966	0,960	Cooling capacity corr. factor
Coeff. correttivo pot. assorbita	1,000	0,995	0,990	0,985	0,975	Power input corr. factor
Coeff. corrett. portata miscela	1,023	1,054	1,092	1,140	1,200	Mixture flow corr. factor
Coeff. corrett. perdita di carico	1,061	1,114	1,190	1,244	1,310	Pressure drop corr. factor

CALCULATION EXAMPLE

An example can help to use properly the coefficients reported in the table.

Suppose that a water chiller SIGMA 282 presents the following performances at the nominal working conditions:

CALCULATION EXAMPLE

An example can help to use properly the coefficients reported in the table.

Suppose that a water chiller SIGMA 282 presents the following performances at the nominal working conditions:

Cooling capacity : 77,1 kW
 Power input : 17,4 kW
 Evap. water temp. in/out: 12/7 °C
 Evap. water flow : 3,684 l/s
 Evap. pressure drop : 39 kPa

Cond. Heating capacity: 77,1+17,4=94,5kW
 Cond. water temp. in/out: 30/35 °C
 Cond. water flow : 4,515 l/s
 Cond. pressure drop : 58 kPa

Evaporator with a 30% and condenser with a 20% glycol mixture these parameters will change to the following values, according to the correction factors:

Cooling capacity : $77,1 \times 0,973 \times 0,98 = 73,5 \text{ kW}$
 Power input : $17,4 \times 0,99 \times 0,995 = 17,1 \text{ kW}$
 Mixture flow : $(73,5 \times 860/5) \times 1,092/3600 =$
 $= 3,83 \text{ l/s}$

From the pressure drop the value corresponding to the new mixture flow
 $3,835 \text{ l/s} \Rightarrow 42 \text{ kPa}$
 Evap. pressure drop : $42,26 \times 1,190 = 50 \text{ kPa}$

Cond. heating capacity : $\text{kW} + \text{kW} = 90,6 \text{ kW}$
 Mixture flow : $(90,6 \times 860/5) \times 1,054/3600 =$
 $= 4,56 \text{ l/s}$

From the pressure drop the value corresponding to the new mixture flow
 $4,562 \text{ l/s} \Rightarrow 59 \text{ kPa}$
 Cond. pressure drop : $59,4 \times 1,114 = 66 \text{ kPa}$

Technical information manual SIGMA
 REF.SIGMA-10230000012_04.08/SIGMA_2011.DOC

LOW TEMPERATURES CORRECTIONS FACTORS

Temperatura uscita miscela Outlet water temperature [°C]	4	2	0	-2	-4
Potenza frigorifera Cooling capacity	0,850	0,786	0,725	0,667	0,612
Potenza assorbita compressore Compressor power input	0,997	0,993	0,993	0,993	0,990
Percentuale di glicole minima Minimum glycol percentage [%]	10	10	20	20	30

CALCULATION EXAMPLE

Suppose that for a SIGMA 322 unit performances should be needed at the following conditions:

- Evap. in/out mixture temperature: 0/-4 °C
- Glycol: 30%
- Condenser outlet water temperature: 35 °C

For such a unit nominal performances (inlet/outlet water temp. 12/7 °C, ambient condenser outlet water temperature: 35 °C) are:

Cooling capacity: 88,5 kW
 Compressor power input: 20,0 kW

Performances at the required conditions can be calculated as follows:

1st step.

Performances are calculated without taking in account the use of glycol mixtures.

Cooling capacity: $88,5 \times 0,612 = 54,2 \text{ kW}$
 Power input: $20 \times 0,99 = 19,9 \text{ kW}$

2nd step.

The use of glycol mixtures is taken in account (please refer to glycol correction factor tables). In our case we have (30% glycol):

Cooling capacity: $54,2 \times 0,973 = 52,8 \text{ kW}$
 Power input: $19,9 \times 0,989 = 19,7 \text{ kW}$
 Mixture flow: $(52,8 \times 860/4) \times 1,092/3600 = 3,444 \text{ l/s}$
 Pressure drop: $23,2 \times 1,190 = 27,6 \text{ kPa}$

Technical information manual SIGMA
REF.SIGMA-1023000012_04.08/SIGMA_2011.DOC

SOUND LEVELS

STANDARD UNIT

MODELLO MODEL	Bande d'ottava [Hz] Octave bands [Hz]																Totale Total	
	63 [dB]		125 [dB]		250 [dB]		500 [dB]		1000 [dB]		2000 [dB]		4000 [dB]		8000 [dB]		dB(A)	
	Lw	Lp	Lw	Lp	Lw	Lp	Lw	Lp	Lw	Lp	Lw	Lp	Lw	Lp	Lw	Lp	Lw	Lp
3.2	86,7	71,6	69,5	54,3	67,8	52,6	68,6	53,4	64,1	48,9	60,8	45,6	57,1	41,9	51,7	36,5	70,2	55,0
4.2	86,9	71,8	69,7	54,5	68,0	52,8	68,8	53,6	64,3	49,1	61,0	45,8	57,3	42,1	51,9	36,7	70,4	55,2
5.2	87,0	71,9	69,8	54,6	68,1	52,9	68,9	53,7	64,4	49,2	61,1	45,9	57,4	42,2	52,0	36,8	70,5	55,3
6.2	87,5	72,4	70,3	55,1	68,6	53,4	69,4	54,2	64,9	49,7	61,6	46,4	57,9	42,7	52,5	37,3	71,0	55,8
7.2	87,9	72,8	70,7	55,5	69,0	53,8	69,8	54,6	65,3	50,1	62,0	46,8	58,3	43,1	52,9	37,7	71,4	56,2
8.2	80,3	64,1	72,3	56,0	70,2	54,0	73,4	57,2	69,6	53,4	68,0	51,7	66,5	50,2	63,7	47,5	75,8	59,5
9.2	80,8	64,6	72,8	56,5	70,7	54,5	73,9	57,7	70,1	53,9	68,5	52,2	67,0	50,7	64,2	48,0	76,3	60,0
10.2	81,4	65,2	73,4	57,1	71,3	55,1	74,5	58,3	70,7	54,5	69,1	52,8	67,6	51,3	64,8	48,6	76,9	60,6
12.2	81,7	65,5	73,7	57,4	71,6	55,4	74,8	58,6	71,0	54,8	69,4	53,1	67,9	51,6	65,1	48,9	77,2	60,9
13.2	82,1	65,9	74,1	57,8	72,0	55,8	75,2	59,0	71,4	55,2	69,8	53,5	68,3	52,0	65,5	49,3	77,6	61,3
14.4	92,4	76,1	75,1	58,8	73,5	57,1	74,3	57,9	69,8	53,4	66,4	50,1	62,7	46,4	57,4	41,0	75,9	59,5
16.4	82,9	65,8	76,3	59,2	79,1	62,0	89,4	72,3	86,9	69,7	89,4	72,3	85,2	68,1	80,1	63,0	94,1	77,0
18.4	83,9	66,8	77,3	60,2	80,1	63,0	90,4	73,3	87,9	70,7	90,4	73,3	86,2	69,1	81,1	64,0	95,1	78,0
20.4	84,4	67,3	77,8	60,7	80,6	63,5	90,9	73,8	88,4	71,2	90,9	73,8	86,7	69,6	81,6	64,5	95,6	78,5
24.4	85,1	68,0	78,5	61,4	81,3	64,2	91,6	74,5	89,1	71,9	91,6	74,5	87,4	70,3	82,3	65,2	96,3	79,2
26.4	85,4	68,3	78,8	61,7	81,6	64,5	91,9	74,8	89,4	72,2	91,9	74,8	87,7	70,6	82,6	65,5	96,6	79,5

Lw: sound power levels in free field conditions calculated according to ISO 3746.

Lp: sound pressure levels at 1 m from the unit in free field measured according to ISO 3746.

THEORETICAL SOUND REDUCING VALUES WITH DISTANCE VARIATION IN FREE FIELD

Distanza Distance	(m)	1	2	3	4	5	6	7	8	9	10
Attenuazione Attenuation	(dB)	0	6	9,5	12	14	15,5	17	18	19	20

Technical information manual SIGMA
REF.SIGMA-1023000012_04.08/SIGMA_2011.DOC

SOUND LEVELS

LOW NOISE UNIT

MODELLO MODEL	Bande d'ottava [Hz] Octave bands [Hz]														Totale Total			
	63 [dB]		125 [dB]		250 [dB]		500 [dB]		1000 [dB]		2000 [dB]		4000 [dB]		8000 [dB]		dB(A)	
	Lw	Lp	Lw	Lp	Lw	Lp	Lw	Lp	Lw	Lp	Lw	Lp	Lw	Lp	Lw	Lp	Lw	Lp
3.2	85,8	70,7	75,5	60,3	67,9	52,7	65,8	50,6	62,1	46,9	58,7	43,5	55,2	40,0	50,2	35,0	68,8	53,6
4.2	86,0	70,9	75,7	60,5	68,1	52,9	66,0	50,8	62,3	47,1	58,9	43,7	55,4	40,2	50,4	35,2	69,0	53,8
5.2	85,9	70,8	75,6	60,4	68,0	52,8	65,9	50,7	62,2	47,0	58,8	43,6	55,3	40,1	50,3	35,1	68,9	53,7
6.2	86,5	71,4	76,2	61,0	68,6	53,4	66,5	51,3	62,8	47,6	59,4	44,2	55,9	40,7	50,9	35,7	69,5	54,3
7.2	86,9	71,8	76,6	61,4	69,0	53,8	66,9	51,7	63,2	48,0	59,8	44,6	56,3	41,1	51,3	36,1	69,9	54,7
8.2	84,0	67,8	74,8	58,5	69,5	53,3	71,6	55,3	66,2	49,9	63,2	47,0	57,8	41,5	50,5	34,3	72,4	56,1
9.2	84,1	67,9	74,9	58,6	69,6	53,4	71,7	55,4	66,3	50,0	63,3	47,1	57,9	41,6	50,6	34,4	72,5	56,2
10.2	84,2	68,0	75,4	58,7	69,7	53,5	71,8	55,5	66,4	50,1	63,4	47,2	58,0	41,7	50,7	34,5	72,6	56,3
12.2	84,5	68,3	75,3	59,0	70,0	53,8	72,1	55,8	66,7	50,4	63,7	47,5	58,3	42,0	51,0	34,8	72,9	56,6
13.2	84,9	68,7	75,7	59,4	70,4	54,2	72,5	56,2	67,1	50,8	64,1	47,9	58,7	42,4	51,4	35,2	73,3	57,0
14.4	90,7	74,4	80,4	64,0	72,8	56,4	70,7	54,3	67,0	50,6	63,5	47,2	60,1	43,7	55,1	38,7	73,7	57,3
16.4	88,3	71,2	79,1	61,9	73,8	56,7	75,8	58,7	70,4	53,3	67,5	50,4	62,1	44,9	54,8	37,7	76,6	59,5
18.4	89,8	72,7	80,6	63,4	75,3	58,2	77,3	60,2	71,9	54,8	69,0	51,9	63,6	46,4	56,3	39,2	78,1	61,0
20.4	90,6	73,5	81,4	64,2	76,1	59,0	78,1	61,0	72,7	55,6	69,8	52,7	64,4	47,2	57,1	40,0	78,9	61,8
24.4	90,9	73,8	81,7	64,5	76,4	59,3	78,4	61,3	73,0	55,9	70,1	53,0	64,7	47,5	57,4	40,3	79,2	62,1
26.4	91,3	74,2	82,1	64,9	76,8	59,7	78,8	61,7	73,4	56,3	70,5	53,4	65,1	47,9	57,8	40,7	79,6	62,5

Lw: sound power levels in free field conditions calculated according to ISO 3746.

Lp: sound pressure levels at 1 m from the unit in free field measured according to ISO 3746.

THEORETICAL SOUND REDUCING VALUES WITH DISTANCE VARIATION IN FREE FIELD

Distanza Distance	(m)	1	2	3	4	5	6	7	8	9	10
Attenuazione Attenuation	(dB)	0	6	9,5	12	14	15,5	17	18	19	20

Technical information manual SIGMA
REF.SIGMA-1023000012_04.08/SIGMA_2011.DOC

OPERATING LIMITS

SIGMA 2002 - R407C

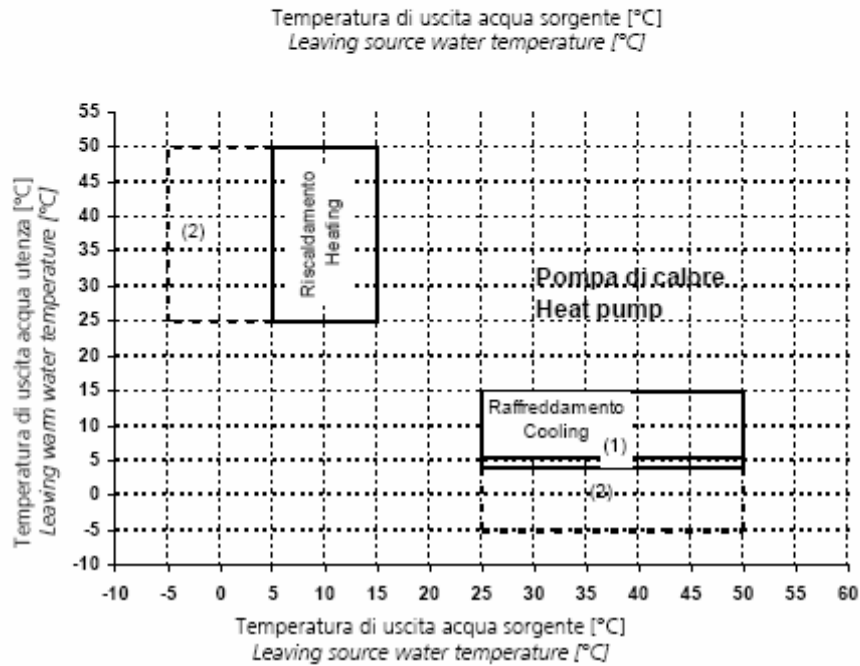
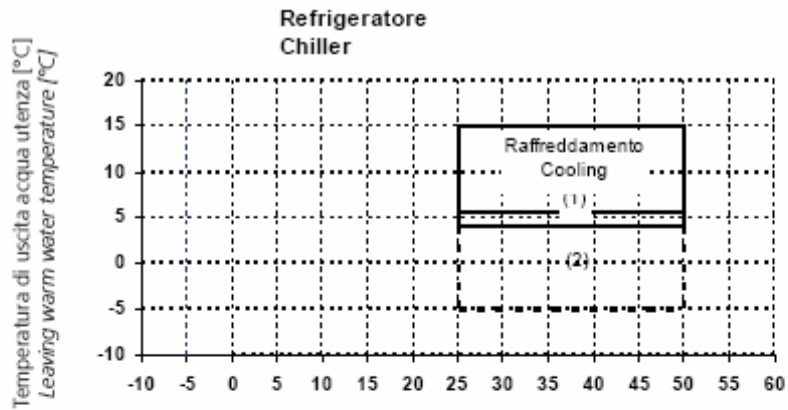

The water temperature rise for all versions must be between 4 °C (min) and 7 °C (max)

(1) Working limits of units with 2 compressors

(2) Working limits of units with glycol and water mixture

Technical information manual SIGMA
REF.SIGMA-10230000012_04.08/SIGMA_2011.DOC

CONDENSER PRESSURE DROP

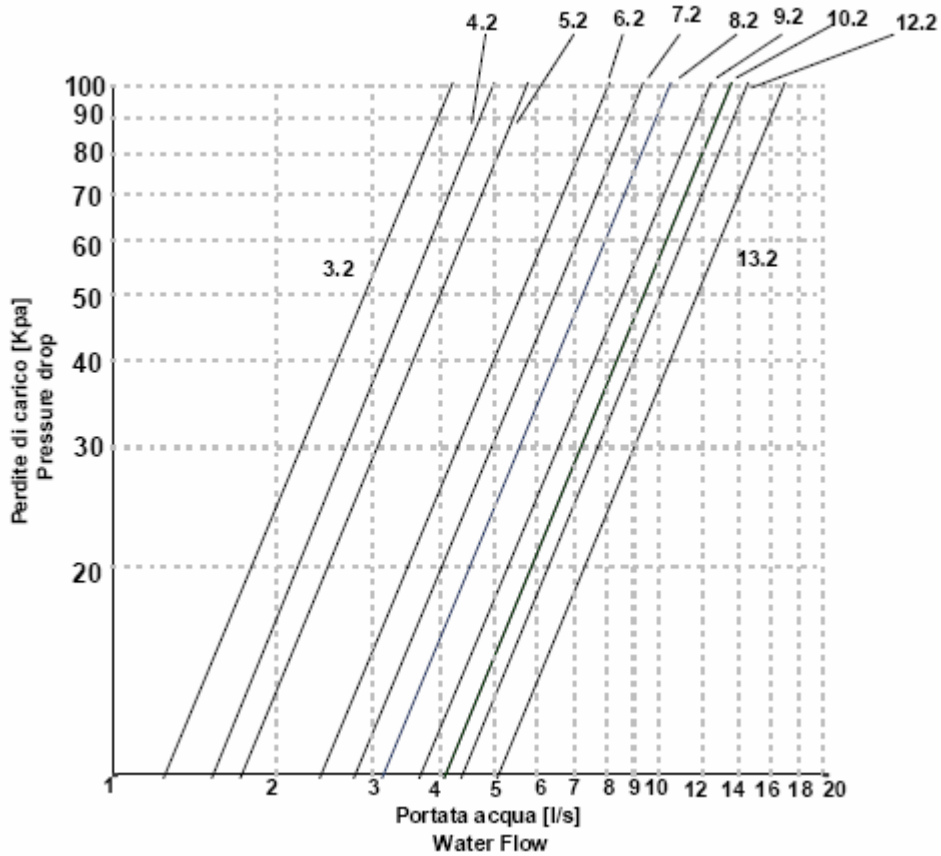

The water temperature rise for all versions must be between 4 °C (min) and 7 °C (max)

Technical information manual SIGMA
REF.SIGMA-10230000012_04.08/SIGMA_2011.DOC

CONDENSER PRESSURE DROP

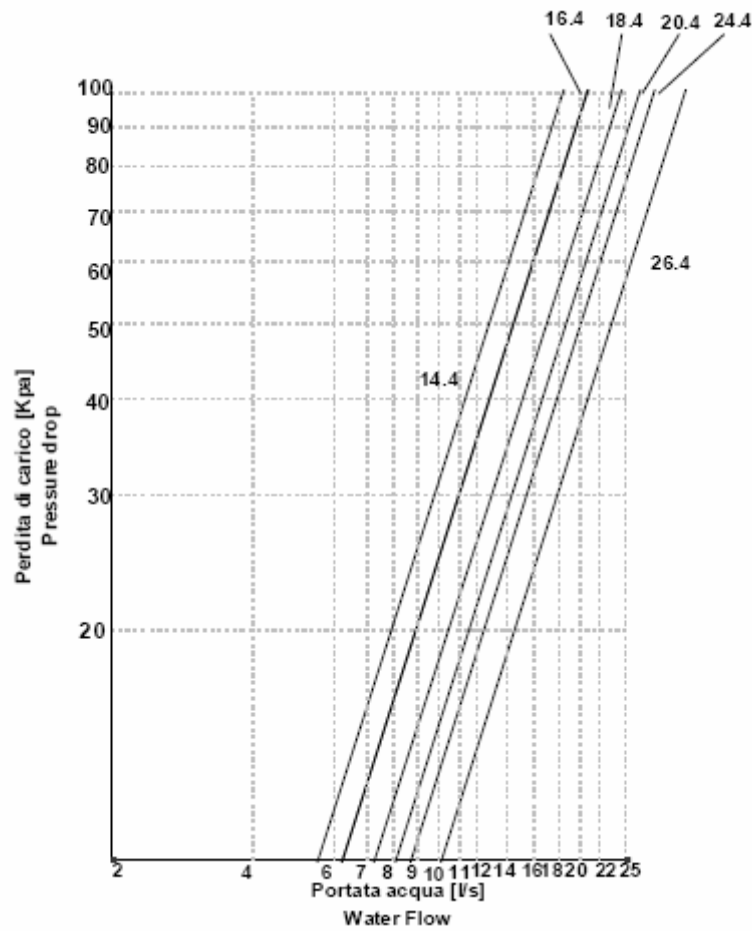

The water temperature rise for all versions must be between 4 °C (min) and 7 °C (max)

Technical information manual SIGMA
REF.SIGMA-10230000012_04.08/SIGMA_2011.DOC

EVAPORATOR PRESSURE DROP

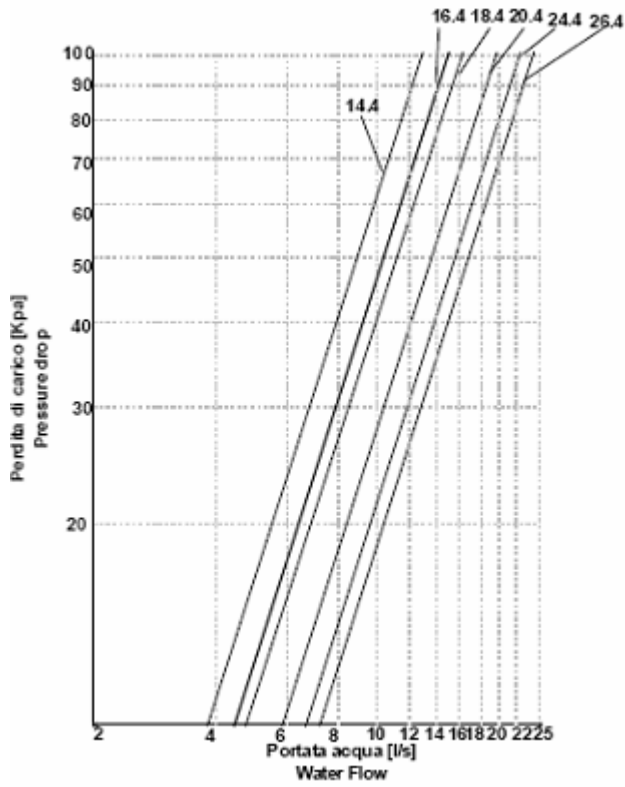
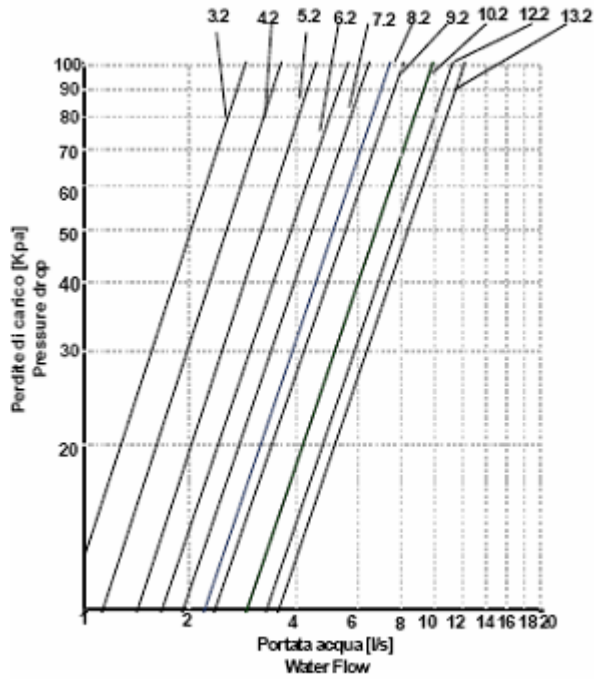

The water temperature rise for all versions must be between 3°C (min) and 8°C (max)

Technical information manual SIGMA
REF.SIGMA-1023000012_04.08/SIGMA_2011.DOC

DIMENSIONS, WEIGHTS AND HYDRAULIC CONNECTIONS

Sigma 2002 – model 3.2 – 7.2

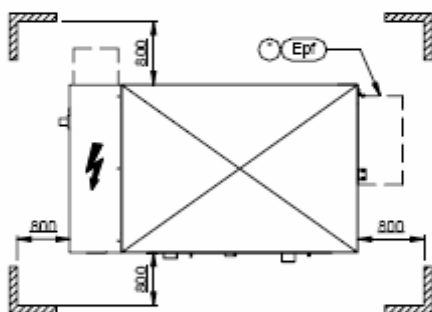
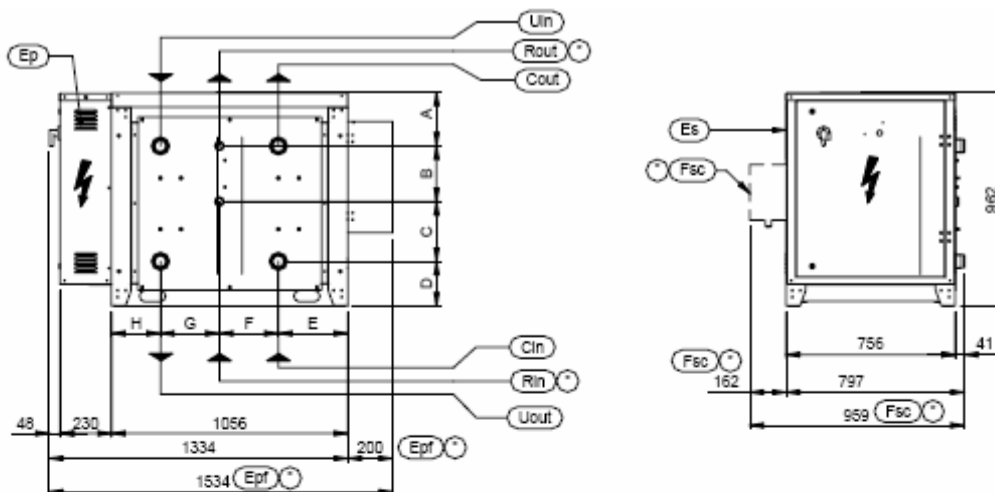

* OPTIONAL

Ep QUADRO ELETTRICO
ELECTRICAL PANEL

Epf QUADRO ELETTRICO RIFASAMENTO UNITÀ
POWER FACTOR CORRECTION ELECTRICAL PANEL

Es INGRESSO ALIMENTAZIONE ELETTRICA
ELECTRICAL SUPPLY INLET

Fsc REGOLATORE DI GIRI VERSIONE LC
FAN SPEED CONTROL LC VERSION

SPAZI DI INSTALLAZIONE
CLEARANCES

Uin	CHILLER, HP, LC, HP/LC	INGRESSO ACQUA UTILIZZO USER WATER INLET
	LE, HP/LE	CONNESSIONI REFRIG. ASPIRAZIONE REFRIGERANT CONNECTION SUCTION
	H	INGRESSO ACQUA EVAPORATORE WATER INLET EVAPORATING
Uout	CHILLER, HP, LC, HP/LC	USCITA ACQUA UTILIZZO USER WATER OUTLET
	LE, HP/LE	CONNESSIONI REFRIG. LIQUIDO REFRIGERANT CONNECTION LIQUID
	H	USCITA ACQUA EVAPORATORE WATER OUTLET EVAPORATING
Cin	CHILLER, H, HP, LE, HP/LE	INGRESSO ACQUA CONDENSAZIONE CONDENSING WATER INLET
	LC, HP/LC	CONNESSIONI REFRIG. LIQUIDO REFRIGERANT CONNECTION LIQUID
Cout	CHILLER, H, HP, LE, HP/LE	USCITA ACQUA CONDENSAZIONE CONDENSING WATER OUTLET
	LC, HP/LC	CONNESSIONI REFRIG. MANDATA REFRIGERANT CONNECTION DISCHARGE
Rin	CHILLER, HP, LC, LE	INGRESSO ACQUA RECUPERO RECOVERY WATER INLET
Rout	CHILLER, HP, LC, LE	USCITA ACQUA RECUPERO RECOVERY WATER OUTLET

Technical information manual SIGMA
REF.SIGMA-1023000012_04.08/SIGMA_2011.DOC

DIMENSIONS, WEIGHTS AND HYDRAULIC CONNECTIONS

Sigma 2002 – model 3.2 – 7.2

MODELLO MODEL	PESO (Kg) WEIGHT (Kg)	PESO IN FUNZIONE (Kg) OPERATING WEIGHT (Kg)	G1 (Kg)	G2 (Kg)	G3 (Kg)	G4 (Kg)
SIGMA 3.2	379	386	130	71	65	120
SIGMA 4.2	403	412	137	78	71	126
SIGMA 5.2	414	425	136	77	77	135
SIGMA 6.2	447	462	137	87	92	146
SIGMA 7.2	470	488	144	92	98	154
SIGMA /H 3.2	379	386	130	71	65	120
SIGMA /H 4.2	403	412	137	78	71	126
SIGMA /H 5.2	414	425	136	77	77	135
SIGMA /H 6.2	447	462	137	87	92	146
SIGMA /H 7.2	470	488	144	92	98	154
SIGMA /LC 3.2	360	364	134	63	54	113
SIGMA /LC 4.2	380	386	142	68	57	119
SIGMA /LC 5.2	386	393	140	66	60	127
SIGMA /LC 6.2	404	412	142	73	67	130
SIGMA /LC 7.2	422	430	150	75	69	136
SIGMA /LC/HP 3.2	399	405	140	70	65	130
SIGMA /LC/HP 4.2	418	424	147	75	68	134
SIGMA /LC/HP 5.2	423	429	145	73	71	140
SIGMA /LC/HP 6.2	442	449	147	80	78	144
SIGMA /LC/HP 7.2	460	468	155	83	80	150
SIGMA /LC/DC-DS 3.2	385	393	142	67	59	125
SIGMA /LC/DC-DS 4.2	409	419	150	72	64	133
SIGMA /LC/DC-DS 5.2	418	430	148	71	68	143
SIGMA /LC/DC-DS 6.2	448	463	150	79	81	153
SIGMA /LC/DC-DS 7.2	470	487	158	82	85	162
SIGMA /LE 3.2	359	363	125	72	61	105
SIGMA /LE 4.2	379	383	130	79	71	108
SIGMA /LE 5.2	382	389	126	79	71	113
SIGMA /LE 6.2	408	418	128	88	82	120
SIGMA /LE 7.2	426	437	134	92	86	125
SIGMA /LE/HP 3.2	395	402	128	80	75	119
SIGMA /LE/HP 4.2	413	419	133	87	78	121
SIGMA /LE/HP 5.2	417	424	130	86	83	125
SIGMA /LE/HP 6.2	435	442	133	91	89	129
SIGMA /LE/HP 7.2	453	461	139	96	92	134
SIGMA /LE/DC-DS 3.2	385	392	133	75	67	117
SIGMA /LE/DC-DS 4.2	408	417	139	83	73	122
SIGMA /LE/DC-DS 5.2	415	425	135	83	79	128
SIGMA /LE/DC-DS 6.2	452	469	137	93	97	142
SIGMA /LE/DC-DS 7.2	475	495	143	99	103	150
SIGMA /HP 3.2	399	409	133	75	73	128
SIGMA /HP 4.2	420	431	140	82	77	132
SIGMA /HP 5.2	428	439	137	81	82	139
SIGMA /HP 6.2	451	464	140	87	91	146
SIGMA /HP 7.2	473	489	147	92	96	154
SIGMA /HP/DS 3.2	405	417	133	76	76	132
SIGMA /HP/DS 4.2	426	439	140	83	80	136
SIGMA /HP/DS 5.2	436	449	137	82	86	144
SIGMA /HP/DS 6.2	460	475	140	88	96	151
SIGMA /HP/DS 7.2	482	498	147	92	100	159
SIGMA /DC-DS 3.2	404	415	138	74	71	132
SIGMA /DC-DS 4.2	432	445	146	81	78	140
SIGMA /DC-DS 5.2	446	462	144	82	85	151
SIGMA /DC-DS 6.2	491	512	145	92	107	168
SIGMA /DC-DS 7.2	518	544	153	98	114	179

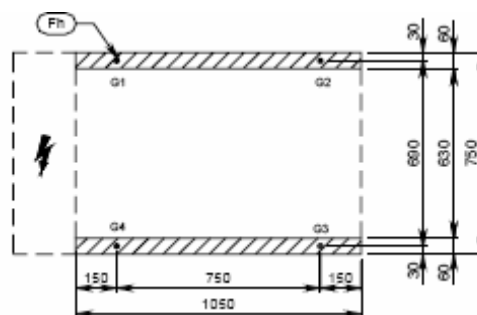

Fh	FORI DI RISSAGGIO FIXING HOLES	Ø 18
G..	PUNTI DI APPOGGIO ANTIVIBRANTI VIBRATION DAMPER FOOT HOLDS	

Technical information manual SIGMA
REF.SIGMA-1023000012_04.08/SIGMA_2011.DOC

DIMENSIONS, WEIGHTS AND HYDRAULIC CONNECTIONS

Sigma 2002 – model 8.2 – 13.2

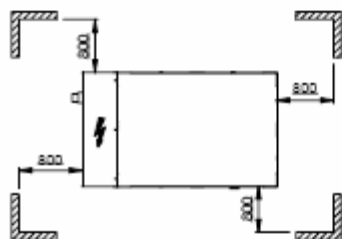
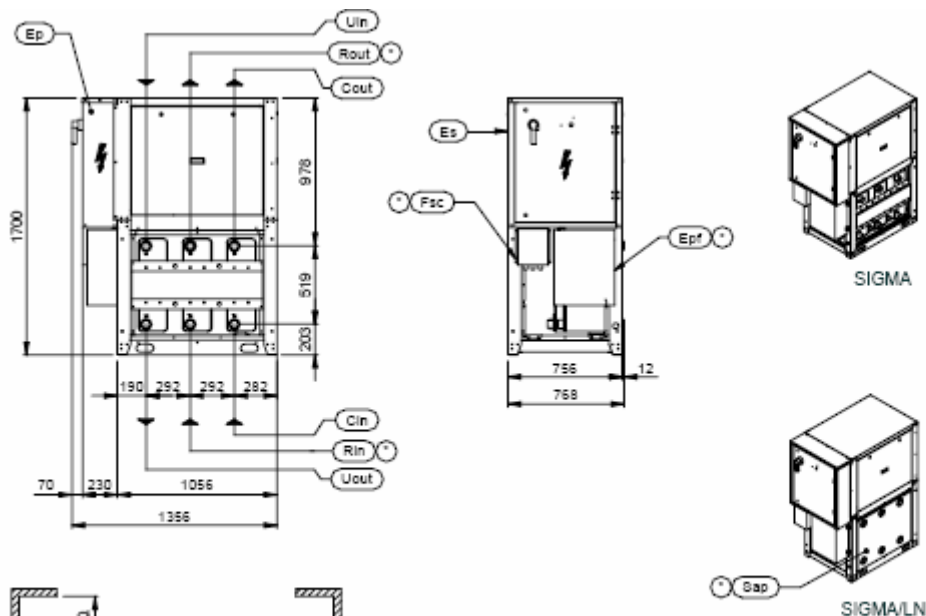

VERSIONE	A	Rin	Rout
DS	250	G1" F	G1" F
DC	519	G2" M	G2" M

*	OPTIONAL
---	----------

Ep	QUADRO ELETTRICO ELECTRICAL PANEL
----	--------------------------------------

Epf	QUADRO ELETTRICO RIFASAMENTO UNITA POWER FACTOR CORRECTION ELECTRICAL PANEL
-----	--

Es	INGRESSO ALIMENTAZIONE ELETTRICA ELECTRICAL SUPPLY INLET
----	---

Fsc	REGOLATORE DI GIRI VERSIONE LC FAN SPEED CONTROL LC VERSION
-----	--

Sap	PANNELLI INSONORIZZANTI VERSIONE LN SOUND ABSORBING PANEL LN VERSION
-----	---

	SPAZI DI INSTALLAZIONE CLEARANCES
--	--------------------------------------

Uin	CHILLER, HP, LC, HP/LC	INGRESSO ACQUA UTILIZZO USER WATER INLET	G2" M
	LE, HP/LE	CONNESSIONI REFRIG. ASPIRAZIONE REFRIGERANT CONNECTION SUCTION	
Uout	H	INGRESSO ACQUA EVAPORATORE WATER INLET EVAPORATING	G2" M
	CHILLER, HP, LC, HP/LC	USCITA ACQUA UTILIZZO USER WATER OUTLET	G2" M
Cin	LE, HP/LE	CONNESSIONI REFRIG. LIQUIDO REFRIGERANT CONNECTION LIQUID	
	H	USCITA ACQUA EVAPORATORE WATER OUTLET EVAPORATING	G2" M
Cout	CHILLER, H, HP, LE, HP/LE	INGRESSO ACQUA CONDENSAZIONE CONDENSING WATER INLET	G2" M
	LC, HP/LC	CONNESSIONI REFRIG. LIQUIDO REFRIGERANT CONNECTION LIQUID	
Rin	CHILLER, H, HP, LE, HP/LE	USCITA ACQUA CONDENSAZIONE CONDENSING WATER OUTLET	G2" M
	LC, HP/LC	CONNESSIONI REFRIG. MANDATA REFRIGERANT CONNECTION DISCHARGE	
Rin	CHILLER, HP, LC, LE	INGRESSO ACQUA RECUPERO RECOVERY WATER INLET	
Rout	CHILLER, HP, LC, LE	USCITA ACQUA RECUPERO RECOVERY WATER OUTLET	

Technical information manual SIGMA
REF.SIGMA-10230000012_04.08/SIGMA_2011.DOC

DIMENSIONS, WEIGHTS AND HYDRAULIC CONNECTIONS

Sigma 2002 – model 8.2 – 13.2

MODELLO MODEL	PESO (Kg) WEIGHT (Kg)	PESO IN FUNZIONE (Kg) OPERATING WEIGHT (Kg)	G1 (Kg)	G2 (Kg)	G3 (Kg)	G4 (Kg)
SIGMA 8.2	483	501	145	84	100	172
SIGMA 9.2	560	582	160	113	128	181
SIGMA 10.2	648	673	194	123	138	218
SIGMA 12.2	688	716	201	136	153	226
SIGMA 13.2	741	775	218	142	163	252
SIGMA /H 8.2	483	501	145	84	100	172
SIGMA /H 9.2	560	582	160	113	128	181
SIGMA /H 10.2	648	673	194	123	138	218
SIGMA /H 12.2	688	716	201	136	153	226
SIGMA /H 13.2	741	775	218	142	163	252
SIGMA /LC 8.2	441	450	154	70	71	155
SIGMA /LC 9.2	514	525	169	98	95	163
SIGMA /LC 10.2	592	605	206	104	99	196
SIGMA /LC 12.2	628	641	213	116	110	202
SIGMA /LC 13.2	673	689	233	119	114	223
SIGMA /LE 8.2	444	456	135	90	92	139
SIGMA /LE 9.2	517	530	147	120	118	145
SIGMA /LE 10.2	596	611	180	131	126	174
SIGMA /LE 12.2	632	648	185	145	140	178
SIGMA /LE/HP 13.2	674	693	199	152	148	194
SIGMA /DC-DS 8.2	546	575	160	91	117	207
SIGMA /DC-DS 9.2	628	660	176	119	147	218
SIGMA /DC-DS 10.2	724	763	210	130	161	262
SIGMA /DC-DS 12.2	769	812	218	143	179	272
SIGMA /DC-DS 13.2	831	882	235	150	193	304
SIGMA /LC/DC-DS 8.2	504	523	169	77	87	190
SIGMA /LC/DC-DS 9.2	581	602	184	104	113	201
SIGMA /LC/DC-DS 10.2	669	694	221	112	121	240
SIGMA /LC/DC-DS 12.2	709	737	229	124	135	249
SIGMA /LC/DC-DS 13.2	762	796	248	128	143	277
SIGMA /LE/DC-DS 8.2	507	528	151	95	109	173
SIGMA /LE/DC-DS 9.2	585	608	164	125	138	181
SIGMA /LE/DC-DS 10.2	673	702	197	137	151	167
SIGMA /LE/DC-DS 12.2	713	745	203	151	167	224
SIGMA /LE/DC-DS 13.2	763	800	217	159	179	245
SIGMA /HP 8.2	477	492	145	82	96	169
SIGMA /HP 9.2	554	574	160	111	124	179
SIGMA /HP 10.2	641	663	195	120	133	215
SIGMA /HP 12.2	681	706	201	134	148	223
SIGMA /HP 13.2	734	764	217	139	159	249
SIGMA /LC/HP 8.2	458	466	153	71	77	165
SIGMA /LC/HP 9.2	531	542	169	99	101	173
SIGMA /LC/HP 10.2	609	622	206	105	105	206
SIGMA /LC/HP 12.2	645	659	213	117	117	212
SIGMA /LC/HP 13.2	687	703	231	119	120	233
SIGMA /LE/HP 8.2	458	467	136	89	95	147
SIGMA /LE/HP 9.2	531	543	149	119	122	153
SIGMA /LE/HP 10.2	609	621	181	129	129	182
SIGMA /LE/HP 12.2	645	659	187	144	143	185
SIGMA /LE/HP 13.2	687	703	200	151	151	201
SIGMA /HP/DS 8.2	501	522	146	84	107	185
SIGMA /HP/DS 9.2	579	602	161	112	135	194
SIGMA /HP/DS 10.2	670	699	196	123	146	234
SIGMA /HP/DS 12.2	710	741	203	136	161	241
SIGMA /HP/DS 13.2	763	799	219	141	172	267

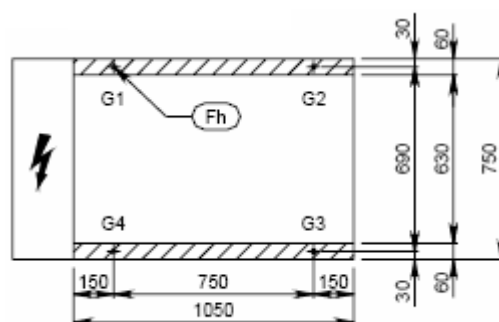

Fh	FORI DI RISSAGGIO FIXING HOLES	Ø 18
G..	PUNTI DI APOGGIO ANTIVIBRANTI VIBRATION DAMPER FOOT HOLDS	

Technical information manual SIGMA
REF.SIGMA-10230000012_04.08/SIGMA_2011.DOC

DIMENSIONS, WEIGHTS AND HYDRAULIC CONNECTIONS

Sigma 2002 – model 8.2 – 13.2

MODELLO MODEL	PESO (Kg) WEIGHT (Kg)	PESO IN FUNZIONE (Kg) OPERATING WEIGHT (Kg)	G1 (Kg)	G2 (Kg)	G3 (Kg)	G4 (Kg)
SIGMA /LN 8.2	514	533	153	92	108	180
SIGMA /LN 9.2	592	612	167	120	136	189
SIGMA /LN 10.2	679	705	202	131	146	226
SIGMA /LN 12.2	720	748	209	144	161	234
SIGMA /LN 13.2	773	805	226	149	171	259
SIGMA /H/LN 8.2	514	533	153	92	108	180
SIGMA /H/LN 9.2	592	612	167	120	136	189
SIGMA /H/LN 10.2	679	705	202	131	146	226
SIGMA /H/LN 12.2	720	748	209	144	161	234
SIGMA /H/LN 13.2	773	805	226	149	171	259
SIGMA /L/C/LN 8.2	472	482	162	78	79	163
SIGMA /L/C/LN 9.2	545	555	176	106	102	171
SIGMA /L/C/LN 10.2	624	637	214	112	107	204
SIGMA /L/C/LN 12.2	660	673	221	124	118	210
SIGMA /L/C/LN 13.2	704	720	240	127	122	231
SIGMA /L/E/LN 8.2	476	487	143	97	100	147
SIGMA /L/E/LN 9.2	549	562	155	128	126	153
SIGMA /L/E/LN 10.2	628	643	188	139	134	182
SIGMA /L/E/LN 12.2	664	680	193	153	148	186
SIGMA /L/E/LN 13.2	705	725	207	160	156	202
SIGMA /D/C-DS/LN 8.2	577	606	168	98	125	215
SIGMA /D/C-DS/LN 9.2	659	691	184	126	155	226
SIGMA /D/C-DS/LN 10.2	756	795	218	137	170	270
SIGMA /D/C-DS/LN 12.2	801	844	226	151	187	280
SIGMA /D/C-DS/LN 13.2	862	912	243	157	201	311
SIGMA /L/C/D-C-DS/LN 8.2	535	555	177	85	95	198
SIGMA /L/C/D-C-DS/LN 9.2	613	633	192	112	121	208
SIGMA /L/C/D-C-DS/LN 10.2	700	726	229	120	129	248
SIGMA /L/C/D-C-DS/LN 12.2	741	769	237	132	143	257
SIGMA /L/C/D-C-DS/LN 13.2	794	828	256	136	151	285
SIGMA /L/E/D-C-DS/LN 8.2	539	560	159	103	117	181
SIGMA /L/E/D-C-DS/LN 9.2	616	640	172	133	146	189
SIGMA /L/E/D-C-DS/LN 10.2	704	734	205	145	159	225
SIGMA /L/E/D-C-DS/LN 12.2	745	777	211	159	175	232
SIGMA /L/E/D-C-DS/LN 13.2	795	832	225	167	187	253
SIGMA /H/P/LN 8.2	508	524	153	90	104	177
SIGMA /H/P/LN 9.2	586	605	168	118	132	187
SIGMA /H/P/LN 10.2	672	694	202	128	141	223
SIGMA /H/P/LN 12.2	713	737	209	141	156	231
SIGMA /H/P/LN 13.2	766	795	225	147	167	256
SIGMA /L/C/H/P/LN 8.2	490	498	161	79	85	173
SIGMA /L/C/H/P/LN 9.2	563	573	176	107	109	181
SIGMA /L/C/H/P/LN 10.2	641	653	213	113	113	214
SIGMA /L/C/H/P/LN 12.2	677	690	221	125	124	220
SIGMA /L/C/H/P/LN 13.2	718	735	239	127	128	241
SIGMA /L/E/H/P/LN 8.2	490	498	144	96	103	155
SIGMA /L/E/H/P/LN 9.2	563	574	157	126	130	161
SIGMA /L/E/H/P/LN 10.2	641	652	189	137	137	189
SIGMA /L/E/H/P/LN 12.2	677	690	194	152	151	193
SIGMA /L/E/H/P/LN 13.2	718	733	207	158	159	209
SIGMA /H/P/DS/LN 8.2	533	554	154	92	115	193
SIGMA /H/P/DS/LN 9.2	610	634	169	120	143	202
SIGMA /H/P/DS/LN 10.2	701	730	204	130	154	242
SIGMA /H/P/DS/LN 12.2	742	773	211	144	169	249
SIGMA /H/P/DS/LN 13.2	795	831	227	149	180	275

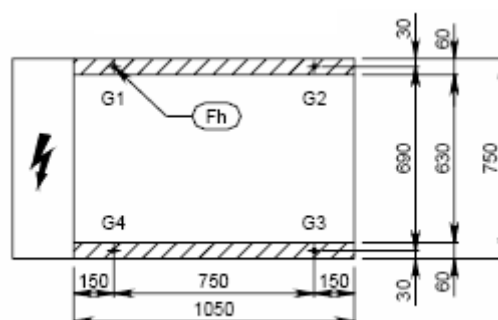

Fh	FORI DI FISSAGGIO FIXING HOLES	Ø 18
G..	PUNTI DI APPOGGIO ANTIVIBRANTI VIBRATION DAMPER FOOT HOLDS	

Technical information manual SIGMA
REF.SIGMA-10230000012_04.08/SIGMA_2011.DOC

DIMENSIONS, WEIGHTS AND HYDRAULIC CONNECTIONS

Sigma 2002 – model 14.4

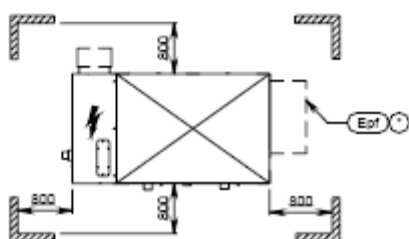
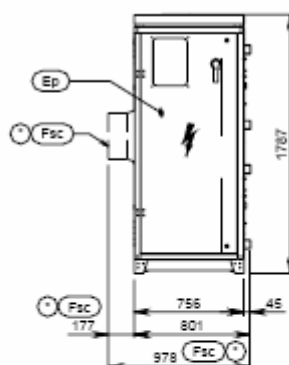
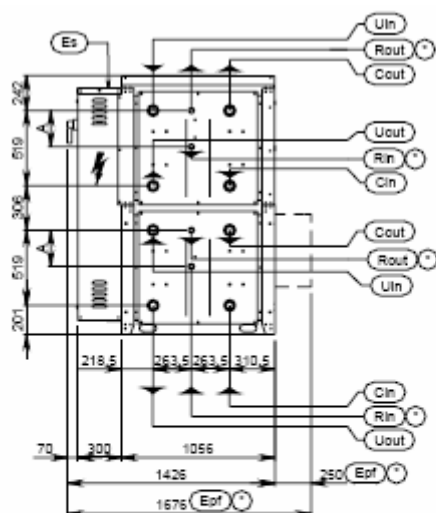

VERSIONE	A	Rin	Rout
DS	250	G1" F	G1" F
DC	219	G2" M	G2" M

Ulin	CHILLER HP, LC, HP/LC	INGRESSO ACQUA UTILIZZO USER WATER INLET	G2" M
	LE, HP/LE	CONNESSIONI REFRIG. ASPIRAZIONE REFRIGERANT CONNECTION SUCTION	
	H	INGRESSO ACQUA EVAPORATORE WATER INLET EVAPORATING	G2" M
Uout	CHILLER HP, LC, HP/LC	USCITA ACQUA UTILIZZO USER WATER OUTLET	G2" M
	LE, HP/LE	CONNESSIONI REFRIG. LIQUIDO REFRIGERANT CONNECTION LIQUID	
	H	USCITA ACQUA EVAPORATORE WATER OUTLET EVAPORATING	G2" M
Cin	CHILLER H, HP, LE, HP/LE	INGRESSO ACQUA CONDENSAZIONE CONDENSING WATER INLET	G2" M
	LC, HP/LC	CONNESSIONI REFRIG. LIQUIDO REFRIGERANT CONNECTION LIQUID	
Cout	CHILLER H, HP, LE, HP/LE	USCITA ACQUA CONDENSAZIONE CONDENSING WATER OUTLET	G2" M
	LC, HP/LC	CONNESSIONI REFRIG. MANDATA REFRIGERANT CONNECTION DISCHARGE	
Rin	CHILLER, HP, LC, LE	INGRESSO ACQUA RECUPERO RECOVERY WATER INLET	G2" M
Rout	CHILLER, HP, LC, LE	USCITA ACQUA RECUPERO RECOVERY WATER OUTLET	G2" M

*	OPTIONAL
Ep	QUADRO ELETTRICO ELECTRICAL PANEL
Epf	QUADRO ELETTRICO RIFASAMENTO UNITA POWER FACTOR CORRECTION ELECTRICAL PANEL
Es	INGRESSO ALIMENTAZIONE ELETTRICA ELECTRICAL SUPPLY INLET
Fsc	REGOLATORE DI GIRI VERSIONE LC FAN SPEED CONTROL LC VERSION
Sap	PANNELLI INSONORIZZANTI VERSIONE LN SOUND ABSORBING PANEL LN VERSION
	SPAZI DI INSTALLAZIONE CLEARANCES

Technical information manual SIGMA
REF.SIGMA-10230000012_04.08/SIGMA_2011.DOC

DIMENSIONS, WEIGHTS AND HYDRAULIC CONNECTIONS

Sigma 2002 – model 14.4

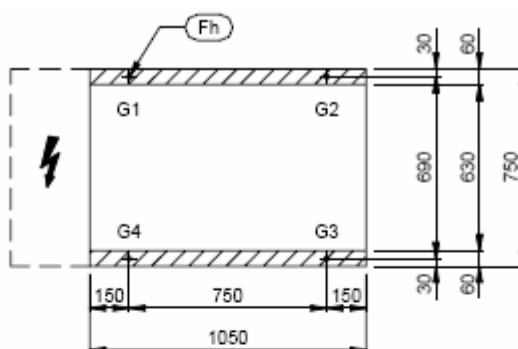

Fh	FORI DI FISSAGGIO FIXING HOLES	Ø 18
----	-----------------------------------	------

G.	PUNTI DI APPOGGIO ANTIVIBRANTI VIBRATION DAMPER FOOT HOLDS
----	---

MODELLO MODEL	PESO (Kg) WEIGHT (Kg)	PESO IN FUNZIONE (Kg) OPERATING WEIGHT (Kg)	G1 (Kg)	G2 (Kg)	G3 (Kg)	G4 (Kg)
SIGMA 14.4	810	842	233	194	189	226
SIGMA /H 14.4	810	842	233	194	189	226
SIGMA /LC 14.4	733	748	248	168	134	198
SIGMA /LC/HP 14.4	764	778	252	173	144	209
SIGMA /LC/DC-DS 14.4	831	864	267	180	168	249
SIGMA /LE 14.4	742	762	215	205	167	175
SIGMA /LE/HP 14.4	576	591	158	142	138	153
SIGMA /LE/DC-DS 14.4	840	878	237	214	203	224
SIGMA /HP 14.4	811	839	237	192	184	226
SIGMA /HP/DS 14.4	829	860	237	194	193	236
SIGMA /DC/DS 14.4	897	947	245	204	226	272

Technical information manual SIGMA
 REF.SIGMA-1023000012_04.08/SIGMA_2011.DOC

DIMENSIONS, WEIGHTS AND HYDRAULIC CONNECTIONS

Sigma 2002 – model 16.4 – 26.4

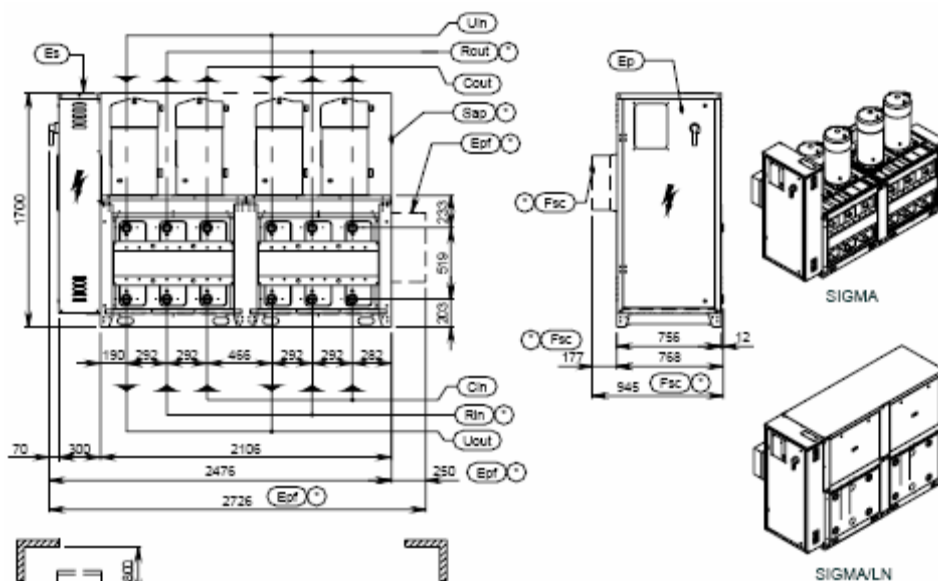

*	OPTIONAL
Ep	QUADRO ELETTRICO ELECTRICAL PANEL
Epf	QUADRO ELETTRICO RIFASAMENTO UNITA POWER FACTOR CORRECTION ELECTRICAL PANEL
Es	INGRESSO ALIMENTAZIONE ELETTRICA ELECTRICAL SUPPLY INLET
Fsc	REGOLATORE DI GIRI VERSIONE LC FAN SPEED CONTROL LC VERSION
Sap	PANNELLI INSONORIZZANTI VERSIONE LN SOUND ABSORBING PANEL LN VERSION
	SPAZI DI INSTALLAZIONE CLEARANCES

Uin	CHILLER, HP, LC, HP/LC	INGRESSO ACQUA UTILIZZO USER WATER INLET	G2" M
	LE, HP/LE	CONNESSIONI REFRIG. ASPIRAZIONE REFRIGERANT CONNECTION SUCTION	
	H	INGRESSO ACQUA EVAPORATORE WATER INLET EVAPORATING	G2" M
Uout	CHILLER, HP, LC, HP/LC	USCITA ACQUA UTILIZZO USER WATER OUTLET	G2" M
	LE, HP/LE	CONNESSIONI REFRIG. LIQUIDO REFRIGERANT CONNECTION LIQUID	
	H	USCITA ACQUA EVAPORATORE WATER OUTLET EVAPORATING	G2" M
Cin	CHILLER, H, HP, LE, HP/LE	INGRESSO ACQUA CONDENSAZIONE CONDENSING WATER INLET	G2" M
	LC, HP/LC	CONNESSIONI REFRIG. LIQUIDO REFRIGERANT CONNECTION LIQUID	
Cout	CHILLER, H, HP, LE, HP/LE	USCITA ACQUA CONDENSAZIONE CONDENSING WATER OUTLET	G2" M
	LC, HP/LC	CONNESSIONI REFRIG. MANDATA REFRIGERANT CONNECTION DISCHARGE	
Rin	CHILLER, HP, LC, LE	INGRESSO ACQUA RECUPERO RECOVERY WATER INLET	G2" M
Rout	CHILLER, HP, LC, LE	USCITA ACQUA RECUPERO RECOVERY WATER OUTLET	G2" M

Technical information manual SIGMA
REF.SIGMA-1023000012_04.08/SIGMA_2011.DOC

DIMENSIONS, WEIGHTS AND HYDRAULIC CONNECTIONS

Sigma 2002 – model 16.4 – 26.4

MODELLO MODEL	PESO (Kg) WEIGHT (Kg)	PESO IN FUNZIONE (Kg) OPERATING WEIGHT (Kg)	G1 (Kg)	G2 (Kg)	G3 (Kg)	G4 (Kg)
SIGMA 16.4	928	966	147	89	93	154
SIGMA 18.4	1069	1116	175	100	103	180
SIGMA 20.4	1210	1262	189	125	126	191
SIGMA 24.4	1226	1286	191	127	130	195
SIGMA 26.4	1270	1340	194	131	139	206
SIGMA /H 16.4	928	966	147	89	93	154
SIGMA /H 18.4	1069	1116	175	100	103	180
SIGMA /H 20.4	1210	1262	189	125	126	191
SIGMA /H 24.4	1226	1286	191	127	130	195
SIGMA /H 26.4	1270	1340	194	131	139	206
SIGMA /LC 16.4	843	860	141	80	76	133
SIGMA /LC 18.4	975	1000	165	95	87	153
SIGMA /LC 20.4	1098	1124	184	112	100	166
SIGMA /LC 24.4	1106	1136	186	112	101	169
SIGMA /LC 26.4	1130	1162	189	112	104	176
SIGMA /LC/HP 16.4	878	898	145	85	80	138
SIGMA /LC/HP 18.4	1023	1048	172	101	93	158
SIGMA /LC/HP 20.4	1146	1174	191	118	106	172
SIGMA /LC/HP 24.4	1154	1182	192	118	107	174
SIGMA /LC/HP 26.4	1314	1376	193	142	150	203
SIGMA /LC/DC-DS 16.4	953	992	156	92	92	156
SIGMA /LC/DC-DS 18.4	1094	1142	181	107	105	178
SIGMA /LC/DC-DS 20.4	1235	1288	201	126	122	195
SIGMA /LC/DC-DS 24.4	1251	1310	203	127	125	200
SIGMA /LC/DC-DS 26.4	1295	1362	208	129	132	212
SIGMA /LE 16.4	851	876	136	88	84	130
SIGMA /LE 18.4	974	998	161	98	91	149
SIGMA /LE 20.4	1106	1136	173	124	113	158
SIGMA /LE 24.4	1114	1148	173	126	116	159
SIGMA /LE 26.4	1134	1176	173	130	122	163
SIGMA /LE/HP 16.4	878	898	141	90	85	133
SIGMA /LE/HP 18.4	1023	1046	168	104	96	155
SIGMA /LE/HP 20.4	1146	1170	180	128	115	162
SIGMA /LE/HP 24.4	1154	1184	180	130	118	164
SIGMA /LE/HP 26.4	1178	1212	180	134	125	167
SIGMA /LE/DC-DS 16.4	960	1004	151	99	100	152
SIGMA /LE/DC-DS 18.4	1093	1142	177	111	109	174
SIGMA /LE/DC-DS 20.4	1243	1302	191	138	135	187
SIGMA /LE/DC-DS 24.4	1259	1322	191	140	140	190
SIGMA /LE/DC-DS 26.4	1299	1374	193	146	150	198
SIGMA /HP 16.4	930	964	149	88	91	154
SIGMA /HP 18.4	1080	1124	177	101	103	181
SIGMA /HP 20.4	1212	1260	191	124	124	191
SIGMA /HP 24.4	1228	1282	192	126	128	195
SIGMA /HP 26.4	1276	1338	195	130	138	206
SIGMA /HP/DS 16.4	985	1030	150	92	104	169
SIGMA /HP/DS 18.4	1135	1190	178	105	116	196
SIGMA /HP/DS 20.4	1275	1338	193	129	139	208
SIGMA /HP/DS 24.4	1291	1356	194	130	142	212
SIGMA /HP/DS 26.4	1339	1414	197	135	152	223
SIGMA /DC-DS 16.4	1037	1096	162	100	109	177
SIGMA /DC-DS 18.4	1188	1258	191	112	121	205
SIGMA /DC-DS 20.4	1347	1428	207	139	148	220
SIGMA /DC-DS 24.4	1371	1460	208	142	154	226
SIGMA /DC-DS 26.4	1435	1540	213	148	167	242

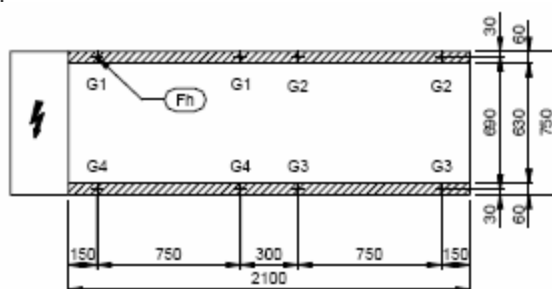

Fh	FORI DI FISSAGGIO FIXING HOLES	Ø 18
G..	PUNTI DI APPOGGIO ANTIVIBRANTI VIBRATION DAMPER FOOT HOLDS	

Technical information manual SIGMA
REF.SIGMA-1023000012_04.08/SIGMA_2011.DOC

DIMENSIONS, WEIGHTS AND HYDRAULIC CONNECTIONS

Sigma 2002 – model 16.4 – 26.4

MODELLO MODEL	PESO (Kg) WEIGHT (Kg)	PESO IN FUNZIONE (Kg) OPERATING WEIGHT (Kg)	G1 (Kg)	G2 (Kg)	G3 (Kg)	G4 (Kg)
SIGMA /LN 16.4	1058	1098	160	108	113	168
SIGMA /LN 18.4	1200	1248	189	119	122	194
SIGMA /LN 20.4	1341	1396	203	144	146	205
SIGMA /LN 24.4	1357	1416	204	146	149	209
SIGMA /LN 26.4	1401	1470	207	149	159	220
SIGMA /LN/H 16.4	1058	1098	160	108	113	168
SIGMA /LN/H 18.4	1200	1248	189	119	122	194
SIGMA /LN/H 20.4	1341	1396	203	144	146	205
SIGMA /LN/H 24.4	1357	1416	204	146	149	209
SIGMA /LN/H 26.4	1401	1470	207	149	159	220
SIGMA /LC/LN 16.4	974	994	162	92	88	155
SIGMA /LC/LN 18.4	1106	1130	183	109	102	171
SIGMA /LC/LN 20.4	1229	1254	197	131	119	180
SIGMA /LC/LN 24.4	1237	1266	198	131	121	183
SIGMA /LC/LN 26.4	1261	1292	202	131	123	190
SIGMA /LC/HP/LN 16.4	1009	1028	167	96	92	159
SIGMA /LC/HP/LN 18.4	1154	1178	190	115	107	177
SIGMA /LC/HP/LN 20.4	1277	1304	204	137	125	186
SIGMA /LC/HP/LN 24.4	1285	1312	205	137	126	188
SIGMA /LC/HP/LN 26.4	1445	1506	206	161	169	217
SIGMA /LC/DC-DS/LN 16.4	1083	1120	177	103	103	177
SIGMA /LC/DC-DS/LN 18.4	1225	1272	199	121	120	196
SIGMA /LC/DC-DS/LN 20.4	1366	1418	214	145	141	209
SIGMA /LC/DC-DS/LN 24.4	1382	1440	216	146	144	214
SIGMA /LC/DC-DS/LN 26.4	1426	1492	221	148	151	226
SIGMA /LE/LN 16.4	981	1006	149	107	103	144
SIGMA /LE/LN 18.4	1105	1130	174	118	110	163
SIGMA /LE/LN 20.4	1237	1266	186	143	132	172
SIGMA /LE/LN 24.4	1245	1278	186	145	135	173
SIGMA /LE/LN 26.4	1265	1306	186	149	141	177
SIGMA /LE/HP/LN 16.4	1009	1026	154	109	104	146
SIGMA /LE/HP/LN 18.4	1154	1176	181	123	115	169
SIGMA /LE/HP/LN 20.4	1277	1302	193	147	135	176
SIGMA /LE/HP/LN 24.4	1285	1314	193	149	137	178
SIGMA /LE/HP/LN 26.4	1309	1342	193	153	144	181
SIGMA /LE/DC-DS/LN 16.4	1091	1134	164	118	119	166
SIGMA /LE/DC-DS/LN 18.4	1224	1274	190	130	129	188
SIGMA /LE/DC-DS/LN 20.4	1374	1434	204	157	155	201
SIGMA /LE/DC-DS/LN 24.4	1390	1454	205	159	159	204
SIGMA /LE/DC-DS/LN 26.4	1430	1506	206	165	170	212
SIGMA /HP/LN 16.4	1061	1096	162	107	111	168
SIGMA /HP/LN 18.4	1211	1256	190	120	123	195
SIGMA /HP/LN 20.4	1343	1392	204	143	144	205
SIGMA /HP/LN 24.4	1359	1410	205	145	147	208
SIGMA /HP/LN 26.4	1407	1468	208	149	157	220
SIGMA /HP/DS/LN 16.4	1116	1158	163	111	123	182
SIGMA /HP/DS/LN 18.4	1266	1318	191	123	135	210
SIGMA /HP/DS/LN 20.4	1406	1468	206	147	159	222
SIGMA /HP/DS/LN 24.4	1422	1486	207	149	162	225
SIGMA /HP/DS/LN 26.4	1470	1544	210	153	172	237
SIGMA /DC-DS/LN 16.4	1168	1226	175	119	129	190
SIGMA /DC-DS/LN 18.4	1319	1388	204	131	140	219
SIGMA /DC-DS/LN 20.4	1478	1560	220	158	168	234
SIGMA /DC-DS/LN 24.4	1502	1590	222	160	173	240
SIGMA /DC-DS/LN 26.4	1566	1670	227	166	187	255

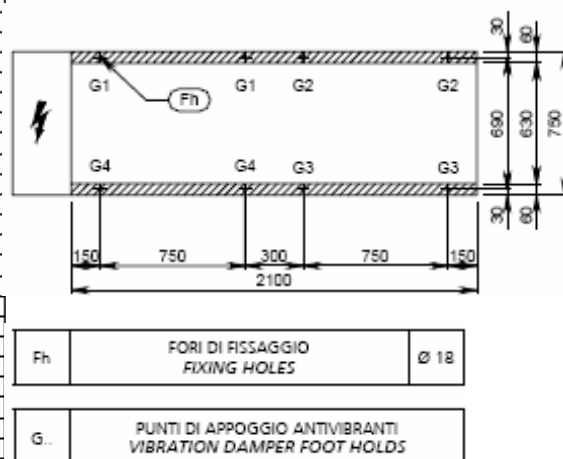

Technical information manual SIGMA
REF.SIGMA-10230000012_04.08/SIGMA_2011.DOC

DIMENSIONS, WEIGHTS AND HYDRAULIC CONNECTIONS

SIGMA 2002/LC - SIGMA 2002/LC/HP - MODEL 8.2 – 13.2

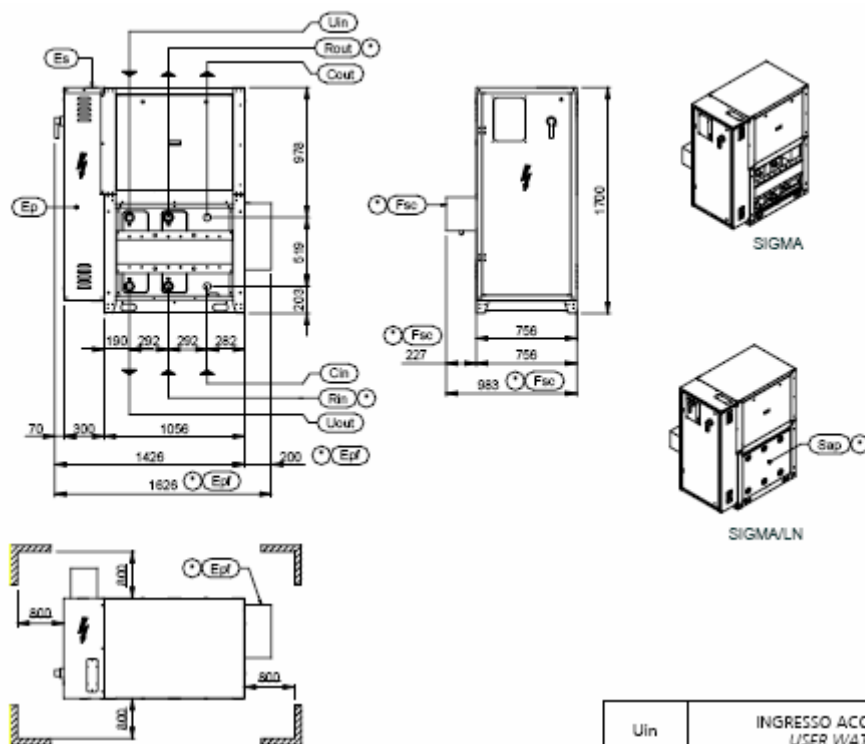

* OPTIONAL

Ep QUADRO ELETTRICO
ELECTRICAL PANEL

Epf QUADRO ELETTRICO RIFASAMENTO UNITÀ
POWER FACTOR CORRECTION ELECTRICAL PANEL

Es INGRESSO ALIMENTAZIONE ELETTRICA
ELECTRICAL SUPPLY INLET

Fsc REGOLATORE DI GIRI VERSIONE LC
FAN SPEED CONTROL LC VERSION

Sap PANNELLI INSONORIZZANTI VERSIONE LN
SOUND ABSORBING PANEL LN VERSION

 SPAZI DI INSTALLAZIONE
CLEARANCES

Uin	INGRESSO ACQUA UTILIZZO USER WATER INLET	G2" M
Uout	USCITA ACQUA UTILIZZO USER WATER OUTLET	G2" M
Cin	CONNESSIONI REFRIG. LIQUIDO REFRIGERANT CONNECTION LIQUID	
Cout	CONNESSIONI REFRIG. MANDATA REFRIGERANT CONNECTION DISCHARGE	
Rin	INGRESSO ACQUA RECUPERO RECOVERY WATER INLET	G2" M
Rout	USCITA ACQUA RECUPERO RECOVERY WATER OUTLET	G2" M

Technical information manual SIGMA
REF.SIGMA-10230000012_04.08/SIGMA_2011.DOC

DIMENSIONS, WEIGHTS AND HYDRAULIC CONNECTIONS

SIGMA 2002/LC - SIGMA 2002/LC/HP - MODEL 8.2 – 13.2

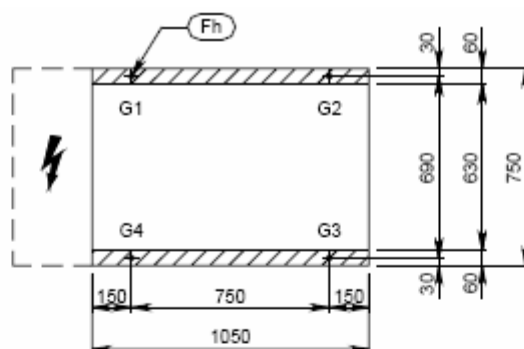

Fh	FORI DI FISSAGGIO FIXING HOLES	Ø 18
----	-----------------------------------	------

G..	PUNTI DI APPOGGIO ANTIVIBRANTI VIBRATION DAMPER FOOT HOLDS
-----	---

MODELLO MODEL	PESO (Kg) WEIGHT (Kg)	PESO IN FUNZIONE (Kg) OPERATING WEIGHT (Kg)	G1 (Kg)	G2 (Kg)	G3 (Kg)	G4 (Kg)
SIGMA /LC 8.2	476	485	180	62	62	181
SIGMA /LC 9.2	549	559	195	89	86	189
SIGMA /LC 10.2	628	640	233	95	90	222
SIGMA /LC 12.2	664	677	240	107	102	228
SIGMA /LC 13.2	708	725	259	110	106	250
SIGMA /LC/HP 8.2	494	502	179	63	68	192
SIGMA /LC/HP 9.2	567	577	195	90	92	200
SIGMA /LC/HP 10.2	645	656	232	96	96	232
SIGMA /LC/HP 12.2	681	694	239	109	108	238
SIGMA /LC/HP 13.2	722	738	258	110	111	259
SIGMA /LC/DC-DS 8.2	539	557	194	69	77	217
SIGMA /LC/DC-DS 9.2	617	638	210	96	104	228
SIGMA /LC/DC-DS 10.2	704	730	247	104	112	267
SIGMA /LC/DC-DS 12.2	745	773	255	116	126	276
SIGMA /LC/DC-DS 13.2	798	831	274	120	133	304
SIGMA /LC/LN 8.2	508	516	188	69	70	189
SIGMA /LC/LN 9.2	581	591	203	97	94	197
SIGMA /LC/LN 10.2	659	672	241	103	98	230
SIGMA /LC/LN 12.2	695	709	248	115	110	236
SIGMA /LC/LN 13.2	740	756	267	118	113	258
SIGMA /LC/HP 8.2	494	502	179	63	68	192
SIGMA /LC/HP 9.2	567	577	195	90	92	200
SIGMA /LC/HP 10.2	645	656	232	96	96	232
SIGMA /LC/HP 12.2	681	694	239	109	108	238
SIGMA /LC/HP 13.2	722	738	258	110	111	259
SIGMA /LC/DC-DS/LN 8.2	571	589	202	77	85	225
SIGMA /LC/DC-DS/LN 9.2	648	669	218	104	112	235
SIGMA /LC/DC-DS/LN 10.2	736	762	255	112	120	275
SIGMA /LC/DC-DS/LN 12.2	776	805	263	124	134	284
SIGMA /LC/DC-DS/LN 13.2	829	863	282	128	141	312

Technical information manual SIGMA

REF.SIGMA-10230000012_04.08/SIGMA_2011.DOC

INSTALLATION RECOMMENDATIONS

Location

- Strictly allow clearances as indicated in the catalogue.
- Locate the unit in order to be compatible with environmental requirements (sound level, integration into the site, etc.).

Electrical connections

- Check the wiring diagram enclosed with the unit, in which are always present all the instructions necessary to the electrical connections.
- Supply the unit at least 12 hours before start-up, in order to turn crankcase heaters on. Do not disconnect electrical supply during temporary stop periods (i.e. weekends).
- Before opening the main switch, stop the unit by acting on the suitable running switches or, if lacking, on the remote control.
- Before servicing the inner components, disconnect electrical supply by opening the main switch.
- The electric supply line must be equipped with an automatic circuit breaker (to be provided by the installer).

Hydraulic connections

- Carefully vent the system, with pump turned off, by acting on the vent valves. This procedure is fundamental: little air bubbles can freeze the evaporator causing the general failure of the system.
- Drain the system during seasonal stops (wintertime) or use proper mixtures with low freezing point. In case of temporary stop periods an electric heater should be installed on the evaporator and hydraulic circuit.
- Install the hydraulic circuit including all the components indicated in the recommended hydraulic circuit diagrams (expansion vessel, flow switch, strainer, storage tank, vent valves, shut off valves, flexible connections, etc.).
- Connect the flow switch, which is furnished on all units, not fitted. Follow the instructions enclosed with the units.

Start up and maintenance operations

- Strictly follow what reported in use and maintenance manual. All these operations must be carried on by trained personnel only.