



Selection: Open-Type Reciprocating Compressors

Input Values

| | | | |
|---------------------------|-----------------|------------------|----------------|
| Compressor model | 4N.2Y-K | Useful superheat | 100% |
| Refrigerant | R134a | Motor speed | 1450 /min |
| Reference temperature | Dew point temp. | Drive | Coupling (1:1) |
| Liq. subc. (in condenser) | 0 K | Capacity control | 100% |
| Suction gas temperature | 20,00 °C | | |

Result

| | | | |
|--------|----------------------------|------------|--------------|
| Q [W] | Cooling capacity | COP [-] | COP/EER |
| Q* [W] | Cooling capacity * | COP* [-] | COP/EER * |
| P [kW] | Power input | m [kg/h] | Mass flow |
| Qc [W] | Condenser Capacity (w. HX) | n [/min] | Compr. speed |

| tc | to | 10°C | 5°C | 0°C | -5°C | -10°C | -15°C | -20°C | -25°C |
|-------------|------------|-------|-------|-------|-------|-------|-------|-------|-------|
| 30°C | Q [W] | 47905 | 39680 | 32606 | 26536 | 21347 | 16928 | 13186 | 10035 |
| | Q* [W] | 47905 | 39680 | 32606 | 26536 | 21347 | 16928 | 13186 | 10035 |
| | P [kW] | 7,53 | 7,28 | 6,95 | 6,56 | 6,13 | 5,65 | 5,16 | 4,65 |
| | Qc [W] | 55060 | 46594 | 39209 | 32770 | 27166 | 22299 | 18086 | 14455 |
| | COP [-] | 6,36 | 5,45 | 4,69 | 4,04 | 3,48 | 2,99 | 2,56 | 2,16 |
| | COP* [-] | 6,36 | 5,45 | 4,69 | 4,04 | 3,48 | 2,99 | 2,56 | 2,16 |
| | m [kg/h] | 1005 | 826 | 673 | 545 | 436 | 344 | 267 | 203 |
| | n [/min] | 1450 | 1450 | 1450 | 1450 | 1450 | 1450 | 1450 | 1450 |
| 40°C | Q [W] | 42471 | 35107 | 28764 | 23316 | 18654 | 14684 | 11322 | 8492 |
| | Q* [W] | 42471 | 35107 | 28764 | 23316 | 18654 | 14684 | 11322 | 8492 |
| | P [kW] | 8,68 | 8,23 | 7,74 | 7,21 | 6,64 | 6,05 | 5,43 | 4,80 |
| | Qc [W] | 50715 | 42928 | 36118 | 30164 | 24964 | 20428 | 16479 | 13047 |
| | COP [-] | 4,89 | 4,26 | 3,72 | 3,23 | 2,81 | 2,43 | 2,09 | 1,77 |
| | COP* [-] | 4,89 | 4,26 | 3,72 | 3,23 | 2,81 | 2,43 | 2,09 | 1,77 |
| | m [kg/h] | 976 | 799 | 649 | 523 | 416 | 326 | 250 | 187,2 |
| | n [/min] | 1450 | 1450 | 1450 | 1450 | 1450 | 1450 | 1450 | 1450 |
| 50°C | Q [W] | 37086 | 30586 | 24978 | 20155 | 16025 | 12508 | 9529 | 7023 |
| | Q* [W] | 37086 | 30586 | 24978 | 20155 | 16025 | 12508 | 9529 | 7023 |
| | P [kW] | 9,73 | 9,15 | 8,51 | 7,85 | 7,14 | 6,40 | 5,64 | 4,84 |
| | Qc [W] | 46334 | 39274 | 33067 | 27609 | 22810 | 18592 | 14884 | 11623 |
| | COP [-] | 3,81 | 3,34 | 2,93 | 2,57 | 2,24 | 1,95 | 1,69 | 1,45 |
| | COP* [-] | 3,81 | 3,34 | 2,93 | 2,57 | 2,24 | 1,95 | 1,69 | 1,45 |
| | m [kg/h] | 944 | 771 | 624 | 500 | 395 | 307 | 233 | 170,9 |
| | n [/min] | 1450 | 1450 | 1450 | 1450 | 1450 | 1450 | 1450 | 1450 |

-- No calculation possible (see message in single point selection)
 *According to EN12900 (20°C suction gas temp., 0K liquid subcooling)

Application Limits Standard 4N.2

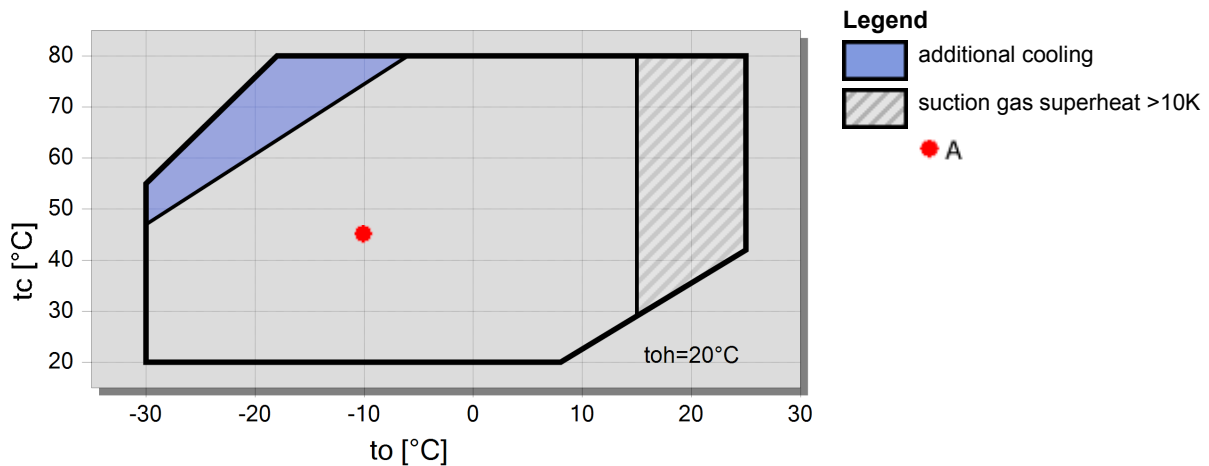



Technical Data: 4N.2Y-K

Dimensions and Connections

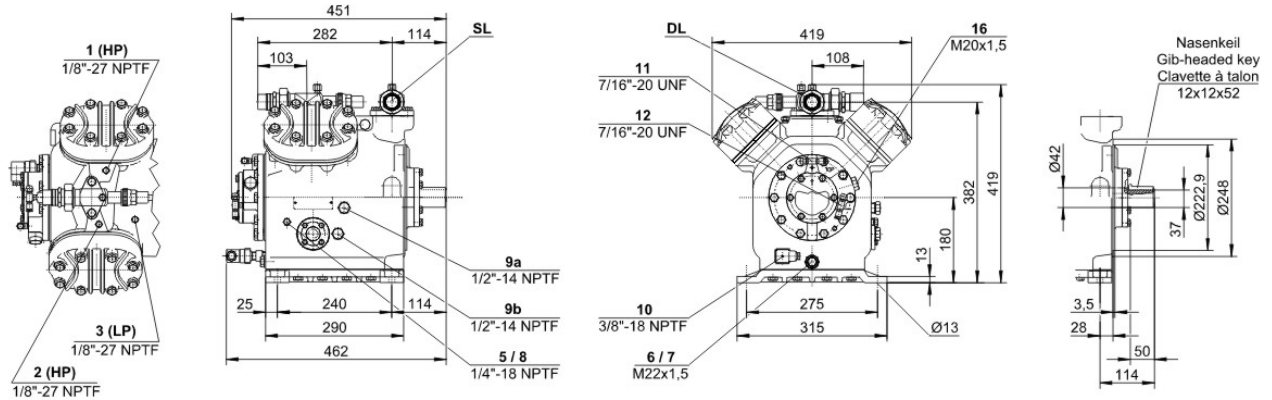

Technical Data

Technical Data

| | |
|--|--|
| Displacement (1450 RPM 50Hz) | 56,1 m3/h |
| Displacement (1750 RPM 60Hz) | 67,7 m3/h |
| No. of cylinder x bore x stroke | 4 x 60 mm x 57 mm |
| Allowed speed range | 750 .. 1750 1/min |
| Weight | 77 kg |
| Max. pressure (LP/HP) | 19 / 25 bar |
| Connection suction line | 35 mm - 1 3/8" |
| Connection discharge line | 28 mm - 1 1/8" |
| Oil type R134a/R407C/R404A/R507A/R407A/R407F | tc<55°C: BSE32 / tc>55°C: BSE55 (Option) |
| Oil type R22 (R12/R502) | B5.2 (Standard) |

Extent of delivery (Standard)

| | |
|--------------------------|----------|
| Oil charge | 4,0 dm3 |
| Protective charge | Standard |
| Suction shut-off valve | Standard |
| Discharge shut-off valve | Standard |

Available Options

| | |
|----------------------------------|---|
| Coupling (...K) w. A/C + medium | KK411 [<11kW] / KK420 [<22kW] (Option) |
| Coupling (...K) w. low temp. | KK415 [<7.5kW] / KK425 [<22kW] (Option) |
| Coupling housing | Option |
| Motor pulley (...S) | 190, 210, 230 mm (Option) |
| V-belts | 3 x SPA (Option) |
| Discharge gas temperature sensor | Option (incl. INT69VS) |
| Start unloading | Option |
| Connection cooling water | R 1/2" (Option) |
| Capacity control | 100-50% (Option) |
| Additional fan | Option |
| Water-cooled cylinder heads | Option |
| Oil service valve | Option |
| Crankcase heater | 100 W (Option) |
| Oil pressure monitoring | MP54 (Option) |
| Kit for marine application | Option |



Open-Type Reciprocating Compressors

Motor Selection

The required driving motor is selected for starting conditions at direct start as well as at star-delta- or PW-start with start unloading (bypass + check valve). The starting conditions refer to the following defined operation points resp. to the maximum application limit of the compressor. Should the evaporation- or the condensing temperature of the plant be higher at the start, an individual motor selection is necessary.

| Evaporation temperature for motor selection | | | | |
|---|--------|----------|-------|--------|
| | HH | H | M | L |
| R134a | +20 °C | +12,5 °C | -5 °C | -20 °C |
| R404A / R507A | | +7,5 °C | -5 °C | -20 °C |
| R407F / R407A | | | | |
| R22 | | +12,5 °C | -5 °C | -20 °C |
| NH□ | +15 °C | +10 °C | -5 °C | |

The stated motor data refer to IEC motors at which the pull-up torque does not fall below 90 % of the max. torque. In addition the following starting torques (referring to direct starting torque) must be reached:

- * 2-cylinder compressors 220 %
- * 4-cylinder compressors 180 %
- * 6-cylinder compressors 160 %

Should the motor not fulfil these criteria, an individual selection is also necessary.

Condenser capacity

The condenser capacity can be calculated with or without heat rejection. This option can be set in the menu Program □ Options. The heat rejection is constantly 5 % of the power consumption. The condensing capacity is to be found in the line cond.cap. (with HR) resp. cond.cap.

Legend of connection positions according to "Dimensions":

- 1 High pressure connection (HP)
 - 2 Connection for discharge gas temperature sensor (HP) (for 4VE(S)-6Y .. 4NE(S)-20(Y) connection for CIC sensor as alternative)
 - 3 Low pressure connection (LP)
 - 4 CIC system: injection nozzle (LP)
 - 4b Connection for CIC sensor
 - 4c Connection for CIC sensor (MP / operation with liquid subcooler)
 - 5 Oil fill plug
 - 6 Oil drain
 - 7 Oil filter (magnetic screw)
 - 8 Oil return (oil separator)
 - 8* Oil return with NH₃ and insoluble oil
 - 9 Connection for oil and gas equalization (parallel operation)
 - 9a Connection for gas equalization (parallel operation)
 - 9b Connection for oil equalization (parallel operation)
 - 10 Oil heater connection
 - 11 Oil pressure connection +
 - 12 Oil pressure connection -
 - 13 Cooling water connection
 - 14 Intermediate pressure connection (MP)
 - 15 Liquid injection (operation without liquid subcooler and with thermostatic expansion valve)
 - 16 Connection for oil monitoring (opto-electrical oil monitoring "OLC-K1" or differential oil pressure switch "Delta-PII")
 - 17 Refrigerant inlet at liquid subcooler
 - 18 Refrigerant outlet at liquid subcooler
 - 19 Clamp space
 - 20 Terminal plate
 - 21 Maintenance connection for oil valve
 - 22 Pressure relief valve to the atmosphere (discharge side)
 - 23 Pressure relief valve to the atmosphere (suction side)
- SL Suction gas line
DL Discharge gas line
- Dimensions can show tolerances according to EN ISO 13920-B.