

# NINFA-NK

COMPACT AND SILENT



- ➔ The solution for above-ground pools or small size traditional pools
- ➔ Easy-open transparent lid (no tools required)
- ➔ Usage: for residential pools up to 35 m<sup>3</sup>
- ➔ Prefilter size: 1.25 L

	Code	Ref.	Type HP	P2 (W) <sup>1</sup>	P1 (W) <sup>2</sup>	Amps (A) <sup>3</sup>	A (mm)	Flow rate (m <sup>3</sup> /h)*	Weight (kg)	Pack. (mm)	qty/pallet
SINGLE PHASE	010101021000	NK 25M	0.25	184	270	1.5	422	4	5.6	245 x 220 x 440	42
	010101121000	NK 33M	0.33	243	360	2.3	422	6.4	6	245 X 220 X 440	42
	010101221000	NK 51M	0.50	368	530	2.9	422	7.5	6.3	245 X 220 X 440	42

<sup>1</sup> Nominal power of the motor P2 (W)    <sup>2</sup> P1 Max (W) (Maximum consumption of the pump)    <sup>3</sup> Amps at P1 Max (A)    \* 8 m water column pressure    M.O.Q. : 1

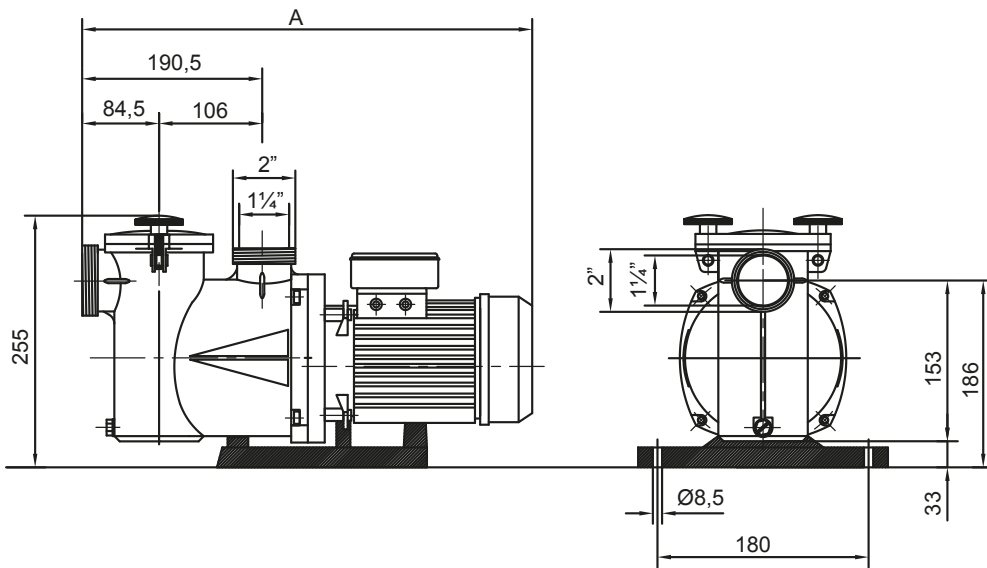

Technical Specifications	
Max. water temp. / Max. pressure	50°C/ 2,5 bar
Connection threaded	2" external and 1 1/4" internal
Mechanical seal	AISI 316, suitable for salt water
Motor-drive specifications	Class F, IP55, 50 Hz (60 Hz, ask), 2.850 rpm
Housing/impeller/strainer/lid	PP + F.G./Noryl®/PP/SAN®

