

CHEMICAL

OIL & GAS

REFRIGERATION

POWER GENERATION

SERVICE



Convincing worldwide:  
**HERMETIC** pumps  
in the refrigeration industry

 **LEDERLE**  
**Hermetic**

*Simply* the best pump technology



## HERMETIC – synonym for hermetically sealed pumps and reliability.

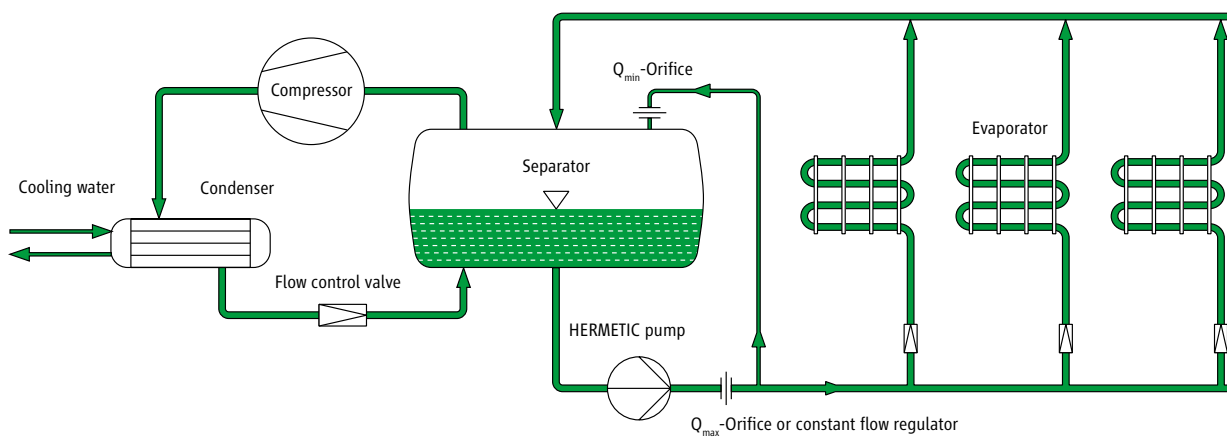

The figure shows the simplified scheme of a large refrigeration plant. The characteristic of this plant is that the refrigerant flows through a central fluid separator and is then conveyed to the evaporators. The resulting vapour and the surplus fluid return

back to the separator. Compressor, condenser and flow control are incorporated in a secondary circuit.

Hermetically sealed pumps ensure a safe and controlled conveying of refrigerants. Besides absolute tightness

HERMETIC refrigeration pumps feature the following:

- long service life
- low operating costs
- rapid and reduced acquisition and stockkeeping of spare parts.

## SINGLE-STAGE CANNED MOTOR PUMPS

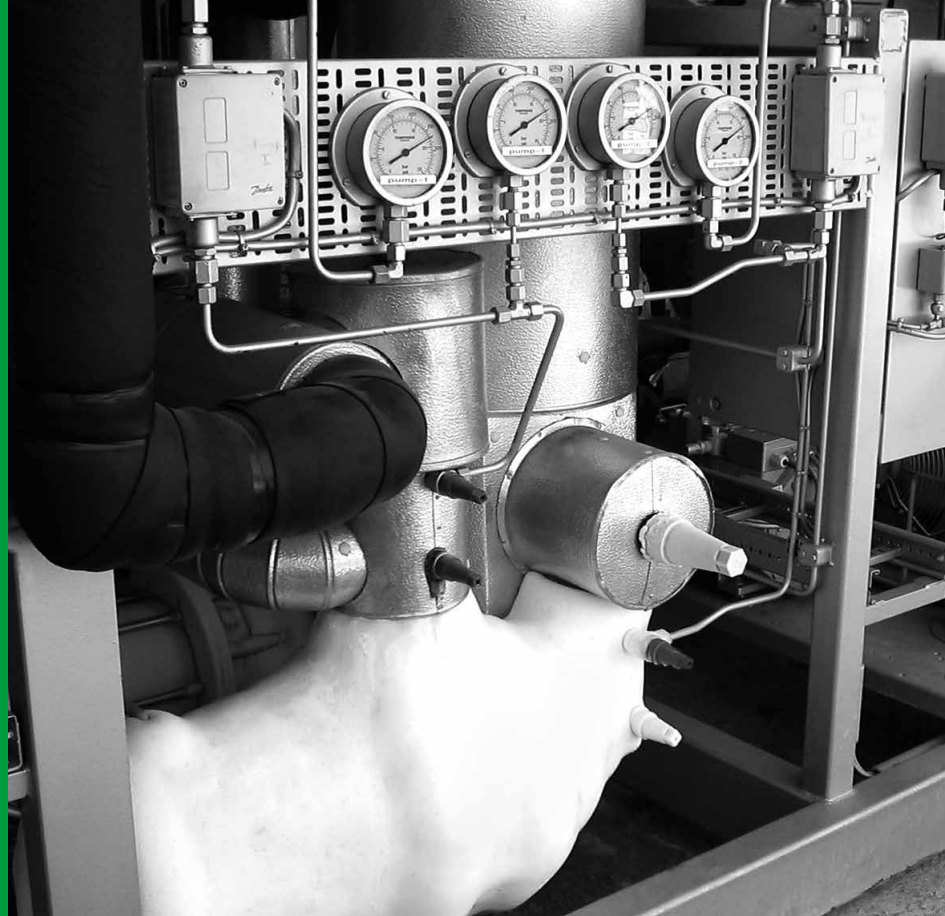

### *General*

HERMETIC pumps are completely self-contained centrifugal pumps without any shaft sealing, driven electromagnetically by the canned motor.

The CNF model has been specially developed for pumping liquefied petroleum gas. This single-stage pump design now allows for the pumping of liquefied petroleum gases with an extremely steep vapour pressure diagram. There is no need for external re-circulation of the partial flow into the suction vessel and the separator.

### *Design*

The pumps use a single-stage impeller mounted directly on an integral induction motor. The pump volute casings and impellers are derived from the standard chemical pumps as defined by EN 22858; ISO 2858.

### *Operating range*

Capacity Q: max. 50 m<sup>3</sup>/h  
Head H: max. 57 m.c.l.

### *Operation*

The partial flow for cooling the motor and lubricating the slide bearings is separated through a ring filter and, after having passed through the motor, is carried back again to the delivery side of the pump. An auxiliary impeller serves to overcome the hydraulic losses encountered along the way.

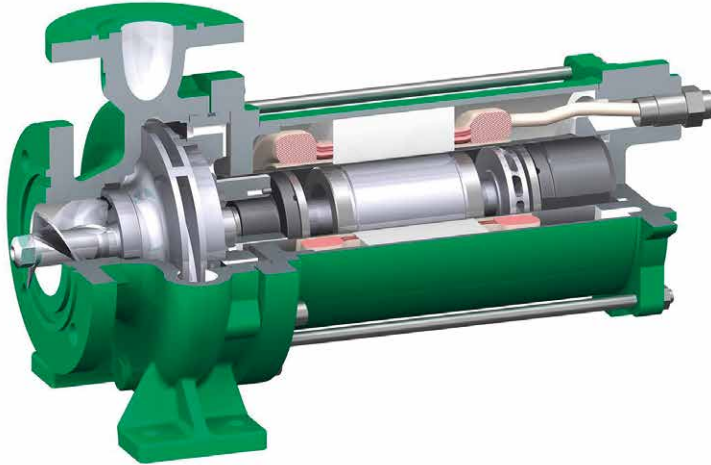

The return of the partial flow to the delivery side ensures that point 3 in the Pressure-Temperature-Diagram (Figure 1) is sufficiently distanced from the boiling-point curve of the diagram. With the CNF model, it is thus possible to pump liquefied petroleum gases with an extremely steep vapour pressure diagram conditions being the same, except for the gas to be pumped.

### Bearings

Slide bearings radially guide the common pump and rotor shaft. This guiding is used during the starting phase and the stopping phase since the guiding function is hydrodynamically taken over by the rotor after the nominal speed of the canned motor has been reached. The axial thrust of our pumps is hydraulically balanced. The pumps are maintenance-free during operation.

### Safety Devices and Monitoring

We recommend to protect HERMETIC pumps against any extreme flow conditions by means of two orifices. Orifice 1 ( $Q_{\min}$ ) ensures the minimum flow rate required for the dissipation of the motor heat loss. Orifice 2 ( $Q_{\max}$ ) ensures the minimum differential pressure in the rotor chamber needed for stabilising the hydraulic axial thrust balance and for avoiding the evaporation of the partial flow. Moreover, this orifice prevents an interruption of the flow of discharge if only a certain minimum suction head is available. Alternatively to orifice 2 ( $Q_{\max}$ ) a constant flow regulator can be installed (see page 22-24).

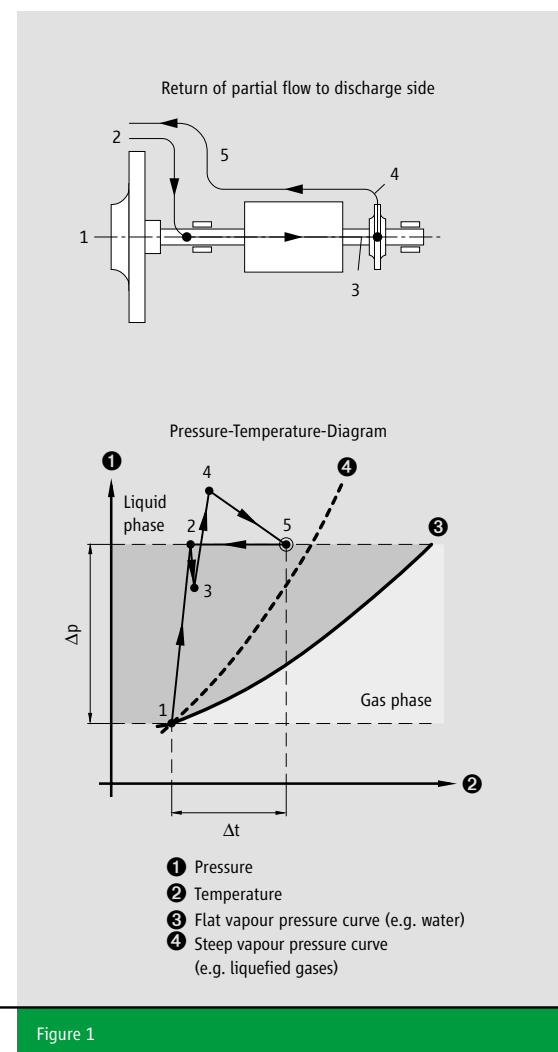

Figure 1

## MULTISTAGE CANNED MOTOR PUMPS



### *General*

The CAM und CAMR range of HERMETIC pumps are completely closed. They operate using the canned motor principle which removes the need for any shaft seal. The CAM and CAMR ranges have been developed especially for the refrigeration applications, their features include:

- low NPSH values
- pump built in two to six stages to suit the application
- able to pump 14 m<sup>3</sup>/h with a suction head of only 0.3-0.5 m
- suitable for pumping ammonia, CO<sub>2</sub>, freons and other refrigerants
- the machines were examined by several classification companies and also have approval for use on ships

The CAMR range is a special version of the CAM 2 range designed for compact plants with small collecting vessels.

The design enables:

- space saving by mounting the pump directly under the vessel
- escaping of gas through the suction port, allowing shorter re-starting times
- the hydraulic data and NPSH value are identical to the CAM 2

### *Design*

The pumps use multistage impeller mounted directly on an integral induction motor.

### *Operating range*

Capacity Q: max. 35 m<sup>3</sup>/h  
Head H: max. 170 m.c.l.

**Performance Curve CAM 2900 rpm/50 Hz**

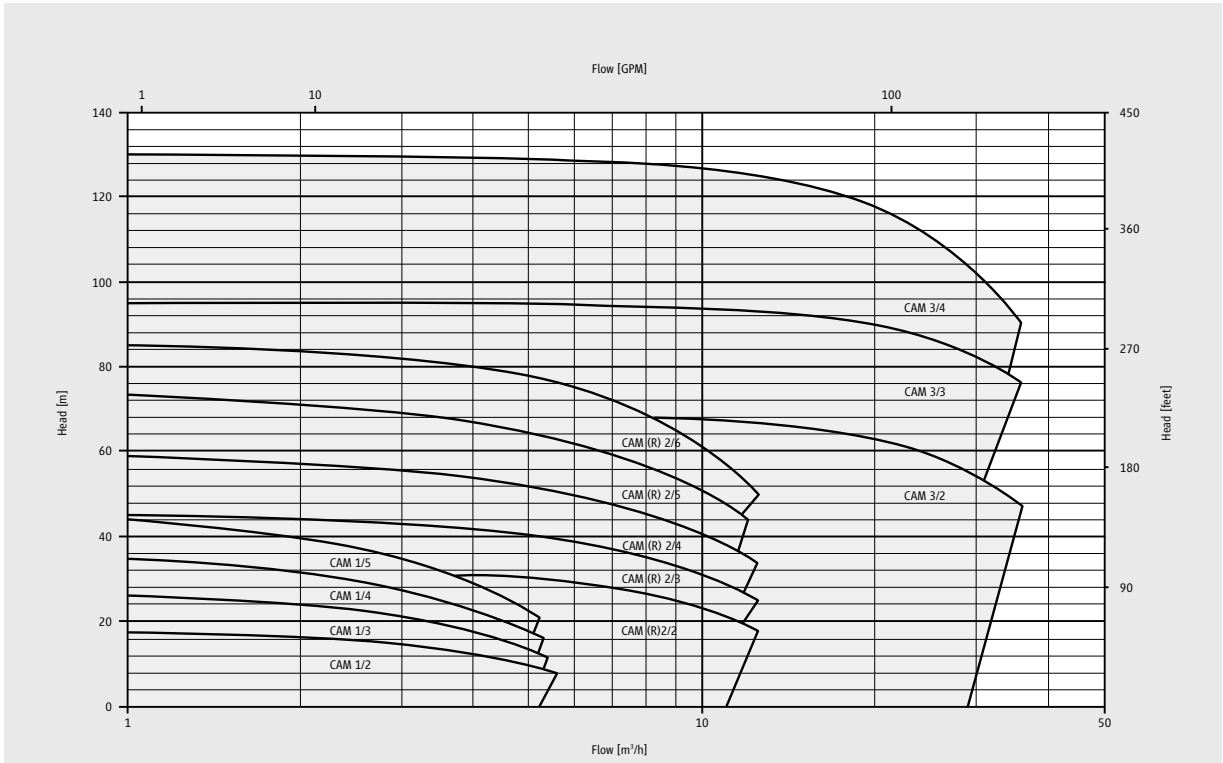

**Performance Curve CAM 3600 rpm/60 Hz**

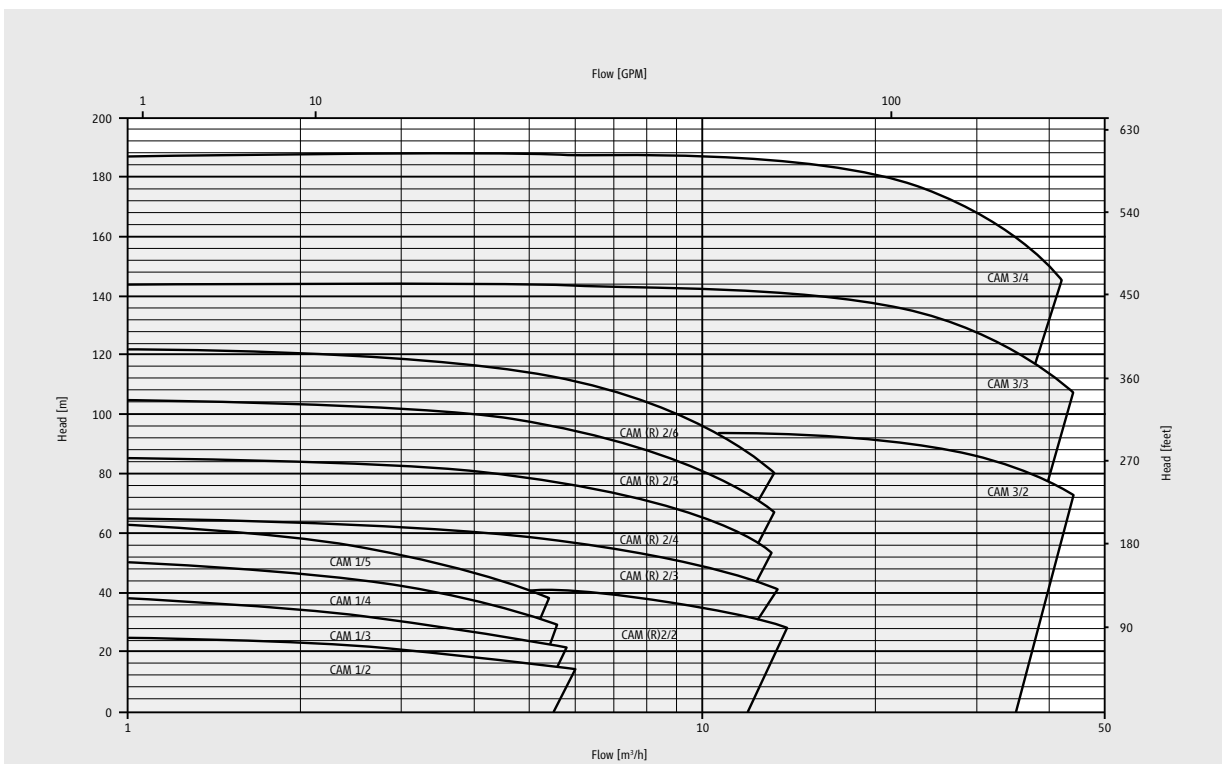

**Materials / Pressure Ratings / Flanges**

Casing	JS 1025
Suction cover (Suction casing CAMR 2)	JS 1025
Stage casing (CAM 1, CAM 2, CAMR 2)	1.0460
Stage casing (CAM 3)	JS 1025
Diffuser insert (Diffuser CAM 3)	JL 1030
Impellers	JL 1030
Bearing	1.4021/carbon
Shaft	1.4021
Stator can	1.4571
Gaskets	AFM 34*
Pressure rating	PN 40**, PN 25
Flanges	according DIN EN 1092-1, PN 40 and PN 25 form D

**Operating Temperature**

Temperature range	-50 °C to +30 °C ***
-------------------	----------------------

**Canned Motors**

Power	up to 25.0 kW
Rotating speed	2800 rpm or 3500 rpm (frequency regulation possible)
Voltage	220, 230, 380, 400, 415, 440, 460, 500, or 575 Volt
Frequency	50 or 60 Hz
Enclosure	IP 55

\* non asbestos

\*\* Test pressure 60 bar

\*\*\* further temperatures on demand

**CAM / CAMR- Design**

Typ	Motor	Pump data		Motor data 50 Hz/ 60 Hz		Weight kg	PN
		Q min. required m <sup>3</sup> /h	Q max. permissible m <sup>3</sup> /h	Power kW	Rated current at 400V/480V		
CAM 1/2	AGX 1.0	0.5	5.0	1.0/1.2	2.7	27.0	40
CAM 1/3	AGX 1.0	0.5	5.0	1.0/1.2	2.7	28.0	40
CAM 1/4	AGX 1.0	0.5	5.0	1.0/1.2	2.7	29.0	40
CAM 1/5	AGX 1.0	0.5	5.0	1.0/1.2	2.7	30.0	40
CAM (R) 2/2	AGX 3.0	1.0	13.0	3.0/3.4	7.1	48.0	40
CAM (R) 2/2	AGX 4.5	1.0	14.0	4.5/5.6	10.4	56.0	40
CAM (R) 2/3	AGX 3.0	1.0	13.0	3.0/3.4	7.1	52.0	40
CAM (R) 2/3	AGX 4.5	1.0	14.0	4.5/5.6	10.4	60.0	40
CAM (R) 2/3	AGX 6.5	1.0	14.0	6.5/7.5	15.2	63.0	40
<b>CAM (R) 2/4</b>	<b>AGX 3.0</b>	<b>1.0</b>	<b>14.0</b>	<b>3.0/3.4</b>	<b>7.1</b>	<b>56.0</b>	<b>40</b>
CAM (R) 2/4	AGX 4.5	1.0	14.0	4.5/5.6	10.4	68.0	40
CAM (R) 2/4	AGX 6.5	1.0	14.0	6.5/7.5	15.2	71.0	40
CAM (R) 2/5	AGX 3.0	1.0	14.0	3.0/3.4	7.1	60.0	40
CAM (R) 2/5	AGX 4.5	1.0	14.0	4.5/5.6	10.4	74.0	40
CAM (R) 2/5	AGX 6.5	1.0	14.0	6.5/7.5	15.2	77.0	40
CAM (R) 2/6	AGX 3.0	1.0	14.0	3.0/3.4	7.1	64.0	40
CAM (R) 2/6	AGX 4.5	1.0	14.0	4.5/5.6	10.4	78.0	40
CAM (R) 2/6	AGX 6.5	1.0	14.0	6.5/7.5	15.2	81.0	40
CAM 3/2	AGX 8.5	6.0	30.0	8.5/9.7	19.0	120.0	40
CAM 3/2	CKPx 12.0	6.0	30.0	13.5/15.7	31.0	150.0	25
CAM 3/3	AGX 8.5	6.0	30.0	8.5/9.7	19.0	138.0	40
CAM 3/3	CKPx 12.0	6.0	30.0	13.5/15.7	31.0	168.0	25
CAM 3/3	CKPx 19.0	6.0	30.0	22.0/25.0	49.5	213.0	25
CAM 3/4	CKPx 12.0	6.0	35.0	13.5/15.7	31.0	186.0	25
CAM 3/4	CKPx 19.0	6.0	35.0	22.0/25.0	49.5	231.0	25

# List of parts CAM 1 / CAM 2

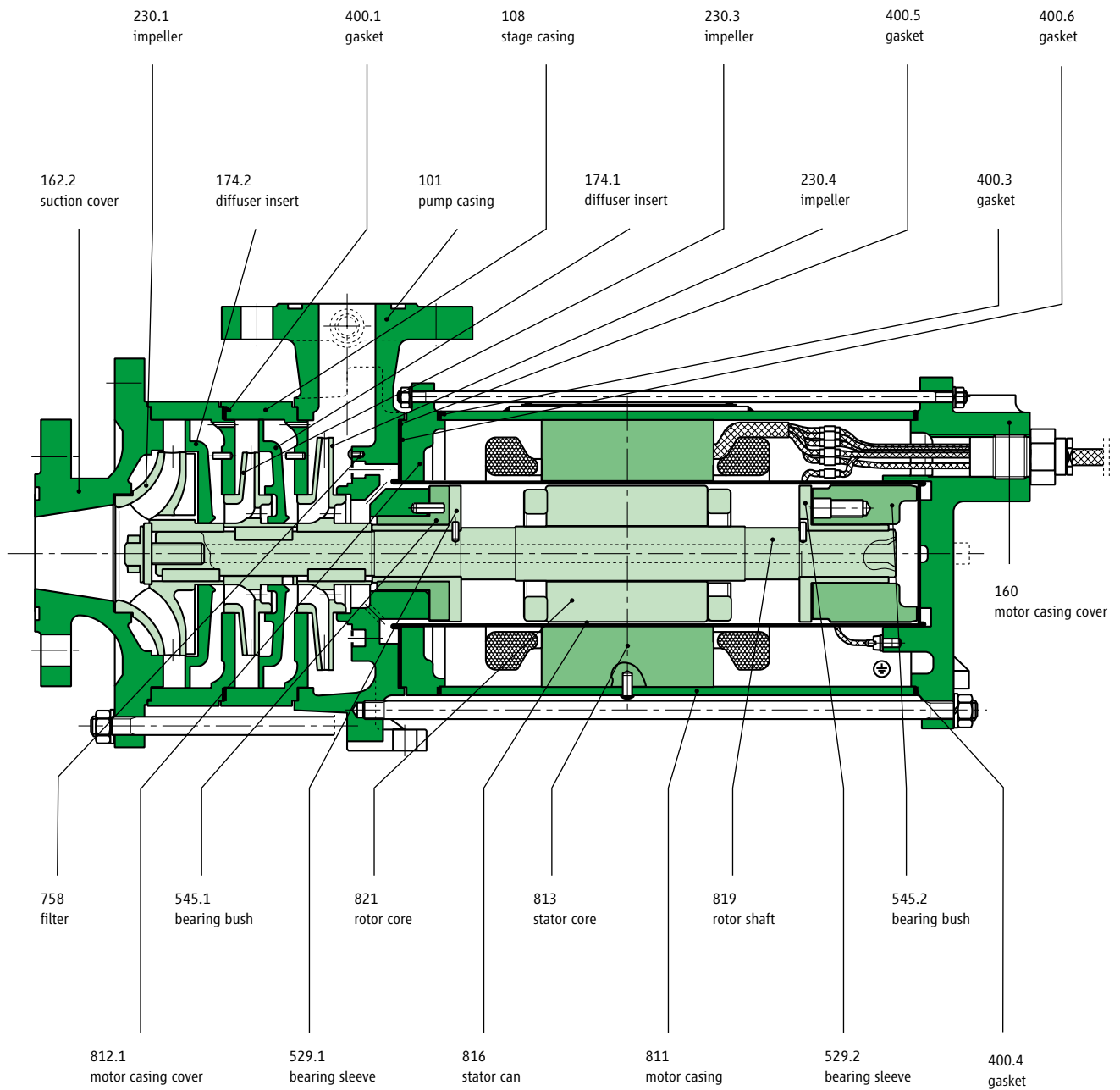



Dimensional drawing for motor type: AGX 1.0 / AGX 3.0 / AGX 4.5 / AGX 6.5

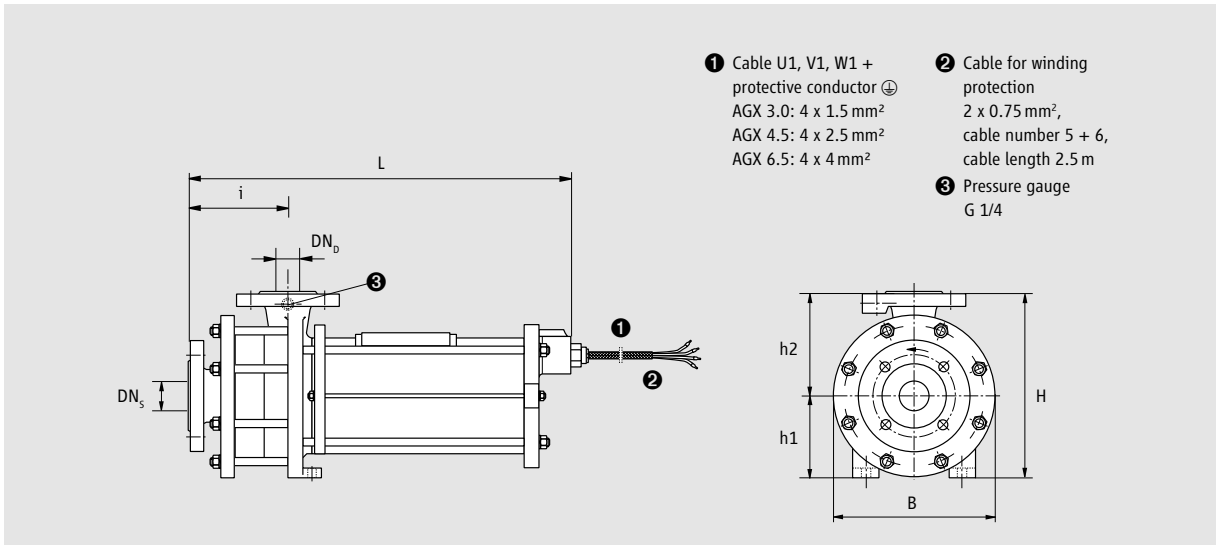

CAM 1-Design

Dimension	CAM	CAM	CAM	CAM
	1/2-stage	1/3-stage	1/4-stage	1/5-stage
	AGX	AGX	AGX	AGX
	1.0	1.0	1.0	1.0
Length/L	419	447	475	503
Width/W	160	160	160	160
Height/H	210	210	210	210
h1	90	90	90	90
h2	120	120	120	120
i	112	140	168	196
DN <sub>s</sub>	25	25	25	25
DN <sub>b</sub>	20	20	20	20

CAM 2-Design

Dimension	CAM	CAM	CAM	CAM	CAM
	2/2-stage	2/3-stage	2/4-stage	2/5-stage	2/6-stage
	AGX	AGX	AGX	AGX	AGX
	3.0/4.5	3.0 to 6.5	3.0 to 6.5	3.0 to 6.5	3.0 to 6.5
Length/L	536	577	618	659	700
Width/W	218	218	218	218	218
Height/H	250	250	250	250	250
h1	110	110	110	110	110
h2	140	140	140	140	140
i	135	176	217	258	299
DN <sub>s</sub>	40	40	40	40	40
DN <sub>b</sub>	32	32	32	32	32