

NB, NBE

Single-stage end-suction pumps
50 Hz



Performance range

NB, NBE

NB, NBE 2-pole

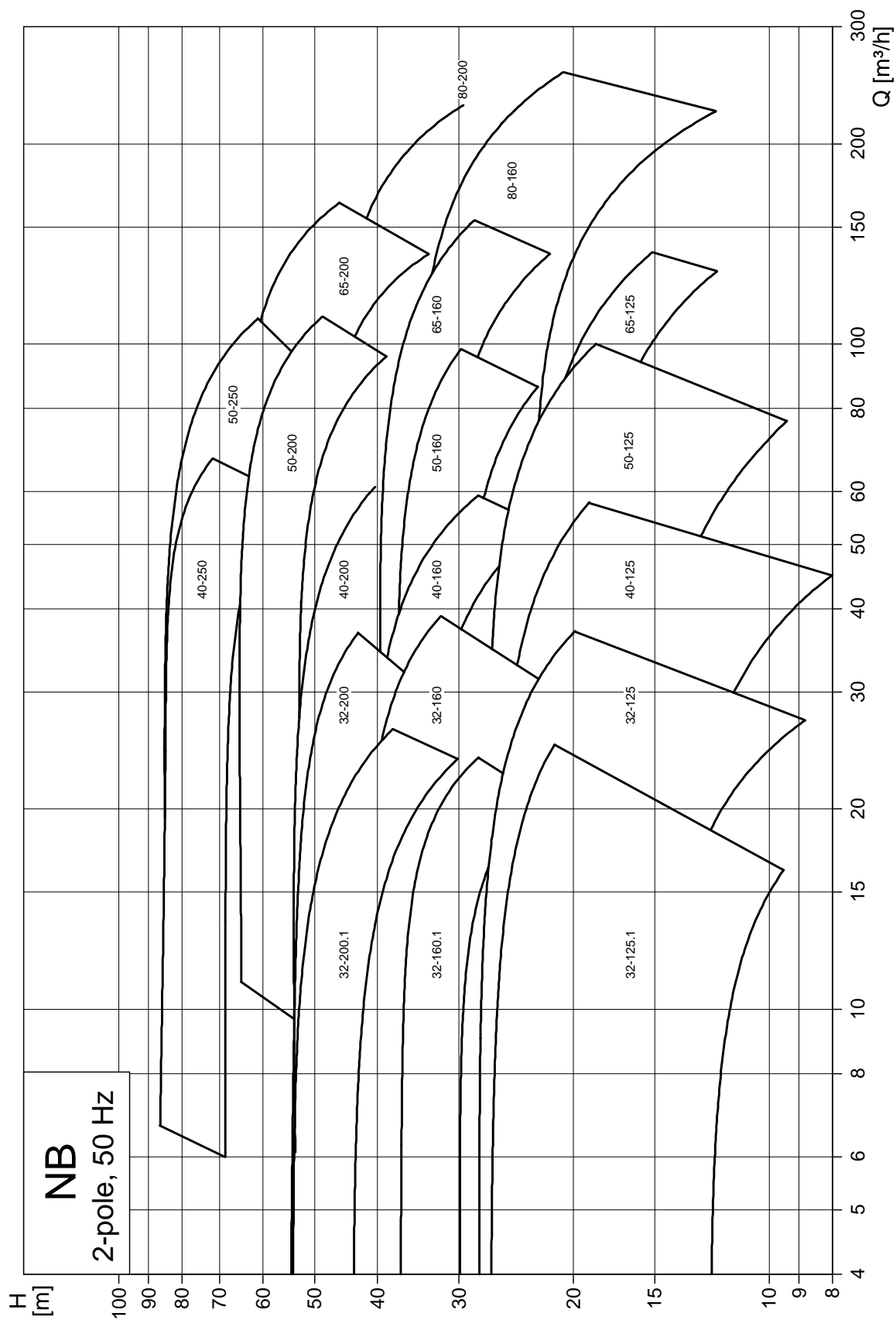

TM03 3336 0606

NB, NBE 50 Hz, 2-pole

Pump type 50 Hz, 2-pole	Design	P ₂ [kW]	Available as E-pump	Pressure stage PN 10	Pressure stage PN 16
NB 32-125.1/100	A	0.75			●
NB 32-125.1/110	A	1.1			●
NB 32-125.1/121	A	1.5	●		●
NB 32-125.1/140	A	2.2	●		●
NB 32-125/106	A	1.1			●
NB 32-125/115	A	1.5	●		●
NB 32-125/130	A	2.2	●		●
NB 32-125/142	A	3.0	●		●
NB 32-160.1/155	A	2.2	●		●
NB 32-160.1/169	A	3.0	●		●
NB 32-160/151	A	3.0	●		●
NB 32-160/163	A	4.0	●		●
NB 32-160/177	A	5.5	●		●
NB 32-200.1/188	A	4.0	●		●
NB 32-200.1/205	A	5.5	●		●
NB 32-200/190	A	5.5	●		●
NB 32-200/206	A	7.5	●		●
NB 40-125/105	A	1.5	●		●
NB 40-125/116	A	2.2	●		●
NB 40-125/127	A	3.0	●		●
NB 40-125/139	A	4.0	●		●
NB 40-160/158	A	5.5	●		●
NB 40-160/172	A	7.5	●		●
NB 40-200/206	B	11.0	●		●
NB 40-250/230	B	15.0	●		●
NB 40-250/245	B	18.5	●		●
NB 40-250/255	B	22.0	●		●
NB 50-125/111	A	3.0	●		●
NB 50-125/121	A	4.0	●		●
NB 50-125/135	A	5.5	●		●
NB 50-125/144	A	7.5	●		●
NB 50-160/150	A	7.5	●		●
NB 50-160/167	B	11.0	●		●
NB 50-200/198	B	15.0	●		●
NB 50-200/210	B	18.5	●		●
NB 50-200/219	B	22.0	●		●
NB 50-250/233	B	22.0	●		●
NB 50-250/254	B	30.0	●		●
NB 65-125/120-110	A	4.0	●		●
NB 65-125/127	A	5.5	●		●
NB 65-125/137	A	7.5	●		●
NB 65-160/157	B	11.0	●		●
NB 65-160/173	B	15.0	●		●
NB 65-200/190	B	18.5	●		●
NB 65-200/198	B	22.0	●		●
NB 65-200/217	B	30.0	●		●
NB 80-160/147-127	B	11.0	●		●
NB 80-160/151	B	15.0	●		●
NB 80-160/161	B	18.5	●		●
NB 80-160/167	B	22.0	●		●
NB 80-200/188	C	30.0	●		●

Type key

NB, NBE

Example	NB 32 -125 .1 /142 A -F -A -BAQE
Type range	
Nominal diameter of discharge port (DN)	
Nominal impeller diameter [mm]	
Reduced performance = .1	
Actual impeller diameter [mm]	
Code for pump version (the codes may be combined ¹⁾):	
A = Basic version	
B = Oversize or double-oversize motor	
C = Without motor	
D = Pump housing with feet	
E = With ATEX approval, certificate or test report	
X = Special version	
Code for pipework connection:	
F = DIN flange	
Code for materials:	
A = Basic version	
B = Bronze impeller	
S = Stainless steel impeller	
Code for mechanical shaft seal and rubber pump parts	

¹⁾ Examples of combined pump version codes:

AE = Basic version with ATEX-approval, certificate or test report

BD = Oversize motor with pump housing with feet

CE = Without motor and with certificate

Mechanical shaft seals

NB, NBE pumps are available as standard with BAQE and GQQE shaft seals. Other shaft seal variants are available on request.

Codes for mechanical shaft seal

The positions (1) - (4) cover four pieces of information about the mechanical shaft seal:

Example	(1)	(2)	(3)	(4)
Grundfos type designation				
Material, rotating seal face				
Material, stationary seat				
Material, secondary seal and other rubber and composite parts, except the wear ring				

The following table explains the positions (1), (2), (3) and (4).

Position	Type	Short description of seal
(1)	A	O-ring seal with fixed driver
	B	Rubber bellows seal
	G	Bellows seal, type B, with reduced seal faces
	D	O-ring seal, balanced
Position	Type	Material
(2) and (3)	Synthetic carbons:	
	A	Carbon, metal-impregnated (antimony (not approved for potable water))
	B	Carbon, synthetic resin-impregnated
(3)	Carbides:	
	Q	Silicon carbide
Position	Type	Material
(4)	E	EPDM
	V	FKM
	F	FXM

The mechanical shaft seal variant codes are used when stamping the nameplates for identification.

General information

Mounting

The pumps are made in three different designs:

- design A: pump housing with feet
- design B: motor with feet
- design C: pump housing and motor with feet.

See the figures below.

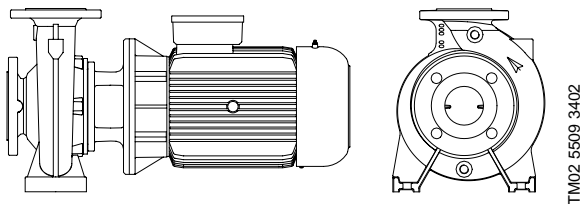

Fig. 2 NB pump design A

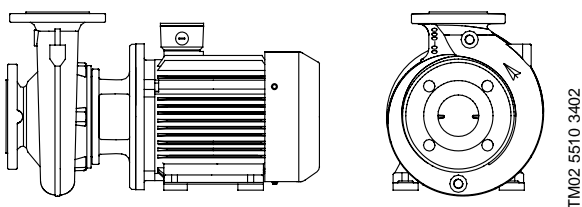

Fig. 3 NB pump design B

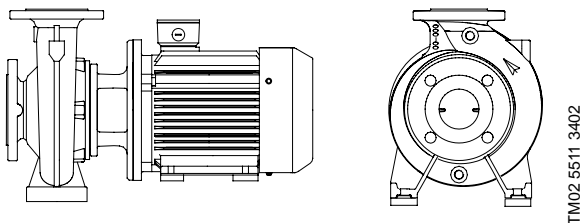
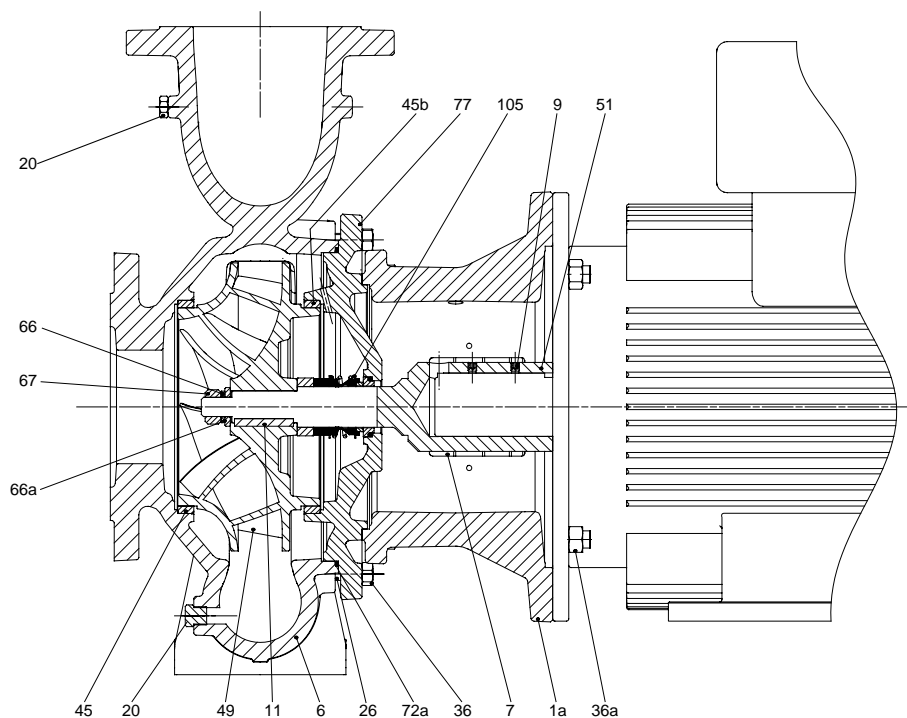

Fig. 4 NB pump design C

Sectional drawing



TM02 9142.2004

Fig. 5 Sectional drawing NB pump

Material specification

Pos.	Component	Materials	DIN W.-Nr.	AISI/ASTM
1a	Motor stool	Cast iron EN-GJL-250	EN-JL1040	A48-40B
6	Pump housing	Cast iron EN-GJL-250	EN-JL1040	A48-40B
7	Coupling guard	Stainless steel	1.4301	AISI 304
9	Set screw	Steel		
11	Parallel key	Steel		
20*	Pipe plug	Steel		
26	Staybolt	Steel		
36, 36a	Nut	Steel		
45	Wear ring	Bronze	2.1096.01	B584 - C83600
45b	Wear ring, upper	Bronze	2.1096.01	B584 - C83600
49	Impeller	Cast iron EN-GJL-200	EN-JL 1030	A48-30B
		Bronze CuSn5Zn5Pb	2.1096.01	B584 - C83600
		Stainless steel **	1.4408	
51	Shaft	Stainless steel/steel	1.4301/1.0301	
		Stainless steel/steel **	1.4401/1.0301	
66	Washer	Stainless steel	100-250	
66a	Spring washer	Stainless steel		
67	Nut	Stainless steel		
72 a	O-ring	EPDM rubber		
77	Cover	Cast iron EN-GJL-250	EN-JL1040	A48-40B
105	Shaft seal	Stainless steel	1.4301	AISI 304

* **NB, NBE:**
 32-125.1 → 80-315: R 3/8"
 100-200 → 150-200: R 1/2"

** A stainless steel impeller is combined with a stainless steel shaft, material 1.4401/1.0301.

Pump location

The pump is designed for installation in a non-aggressive and non-explosive atmosphere.

The relative air humidity must not exceed 95%.

Ambient temperature and altitude

The ambient temperature and the installation altitude are important factors for the motor life, as they affect the life of the bearings and the insulation system.

Ambient temperature must not exceed:

- +40°C for EFF 2 motors
- +60°C for EFF 1 motors.

If the ambient temperature exceeds +40°C (+60°C) or if the motor is installed more than 1000 m (3500 m) above sea level, the motor must not be fully loaded due to the low density and consequently low cooling effect of the air. In such cases, it may be necessary to use a motor with a higher output.

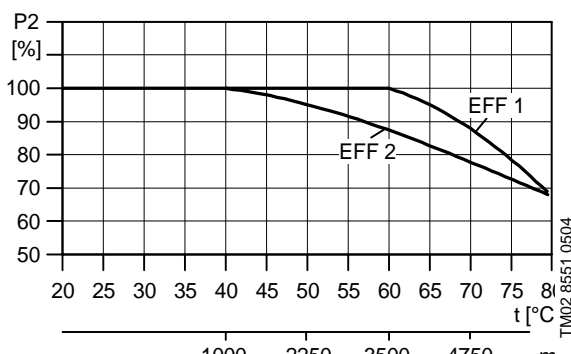

Fig. 8 Motor P2 depends on temperature/altitude

Example:

Fig. 8 shows that the load of an EFF 2-motor must be reduced to 88% when installed 3500 m above sea level.

At an ambient temperature of 70°C the load of an EFF 2-motor must be reduced to 78% of the rated output.

In such situations an oversize motor can be used.

Pumped liquids

NB pumps are suitable for pumping clean, thin, non-aggressive and non-explosive liquids, not containing any solid particles

The effect of viscosity on centrifugal pump performance

A viscous liquid affects a centrifugal pump in several ways.

- The power consumption will be increased, i. e. a larger motor is required.
- Head, flow rate and pump efficiency will be reduced.

The effect of high density on centrifugal pump performance

A high density liquid only affects the power consumption of a centrifugal pump.

- The head, flow rate and pump efficiency will remain unchanged.
- The power consumption will increase at a ratio corresponding to the increase in density. A liquid with a specific gravity of 1.2 will thus require a 20% larger power input.
- An oversize motor will often be required.

WinCAPS can help you select the right pump for liquids with viscosity/density different from those of water.

Liquid temperatures

The NB, NBE pump range covers the temperature range from -25°C (~-13°F) to +140°C (~+284°F). The permissible liquid temperature depends on the mechanical shaft seal type and pump type. See also table below.

Be aware that the maximum liquid temperature limits stated by Grundfos may be overruled by local regulations and various laws.

The maximum liquid temperature is stamped on the nameplate.

Relationship between mechanical shaft seals and temperature

Mechanical shaft seal	Operating temperature	Maximum operating pressure [bar]
BAQE	0°C to +120°C	16 bar
GQQE	-25°C to +90°C	16 bar
BQBE	0°C to +140°C	16 bar
DAQF	0°C to +140°C	16 bar
BQQV ¹⁾	0°C to +90°C	16 bar
BBQE	0°C to +120°C	16 bar
BAQV ¹⁾	0°C to +90°C	16 bar
GQQV ¹⁾	-20°C to +90°C	16 bar
BQQE	-25°C to +90°C	16 bar
AQQE	0°C to +90°C	16 bar
AQQV ¹⁾	0°C to +90°C	16 bar
AQAE	0°C to +120°C	16 bar
AQAV ¹⁾	0°C to +90°C	16 bar

BAQE and GQQE are standard shaft seals.

The remaining shaft seal combinations in the list are available for custom built pumps.

1) The maximum temperature for FKM rubber is 80°C (~176°F) in liquids containing water. For liquids not containing water, such as pure oil, the seal faces of the mechanical shaft seal are the temperature limiting factor.

Communication with NBE pumps

Communication with NBE pumps is possible via a central building management system, remote control (Grundfos R100) or a control panel.

Central building management system

The operator can communicate with an NBE pump even though he is not present near the pump. Communication can take place via a central building management system allowing the operator to monitor and change control modes and setpoint settings.

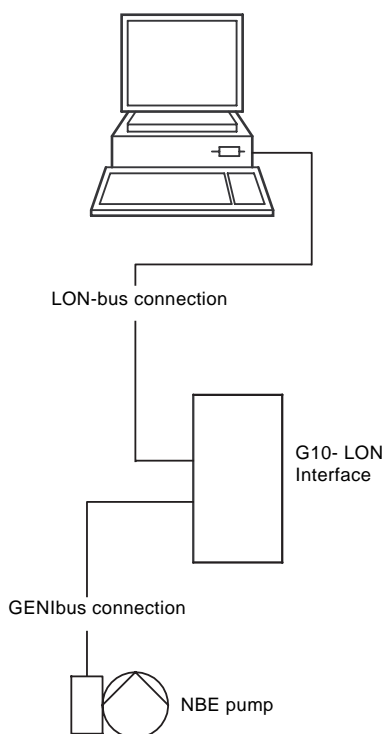

Fig. 13 Structure of a central building management system

TM02 6592 1103

Remote control

The R100 remote control produced by Grundfos is available as an accessory.

The operator can communicate with the NBE pump by pointing the IR-signal transmitter at the control panel of the NBE pump terminal box.

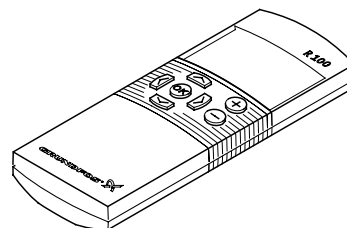

TM00 4498 2802

Fig. 14 R100 remote control

The operator can monitor and change control modes and settings of the NBE pump via the R100 display.

Control panel

The operator can change the setpoint settings manually on the control panel of the NBE pump terminal box.

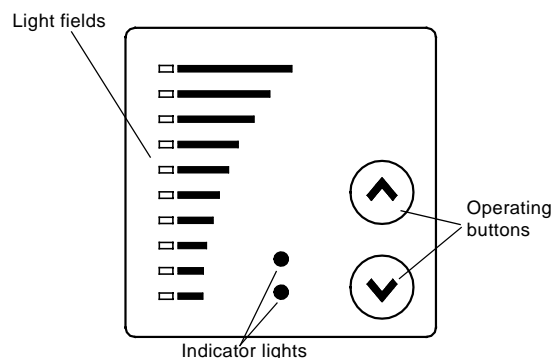

Fig. 15 Control panel of an NBE pump

TM00 7600 0404

Premium range 50 Hz, 6-pole

Frame size	Voltage	P2 [kW]	I _{1/1} [A]	η [%]	Cos φ _{1/1}	n [min ⁻¹]	I _{start} I _{1/1}
MMG 80A-D	3x220-240D/ 380-415Y	0.37	2.2/1.3	60	0.72	910	2.7
MMG 80B-D		0.55	3.1/1.8	67	0.67	910	2.9
MMG 90S-D		0.75	4.3/2.5	70	0.67	910	2.9
MMG 90L-D		1.1	5.9/3.4	72	0.66	910	3.0
MMG 100L-D		1.5	7.6/4.4	72	0.71	930	3.7
MMG 112M-D		2.2	9.4/5.4	80	0.72	940	4.4
MMG 132SA-D		3.0	7.1/4.1	83.7	0.75	955	5.8
MMG 132MA-D		4.0	9.2/5.3	84.9	0.76	955	6.2
MMG 112M-D		2.2	9.4/5.4	80	0.72	940	4.4
MMG 132SA-D		3.0	7.1/4.1	83.7	0.75	955	5.8
MMG 132MA-D	3x380-415D/ 660-690Y	4.0	9.2/5.3	84.9	0.76	955	6.2
MMG 132MB-D		5.5	12.5/7.2	85.2	0.77	955	6.2
MMG 160M-D		7.5	15.9/9.2	87.7	0.82	965	5.9

NBE range 50 Hz, 2-pole

Frame size	Voltage	P2 [kW]	I _{1/1} [A]
MGE 90SB-D	3 x 380-480 V	1.5	3.3 - 2.7
MGE 90LC-D		2.2	4.6 - 3.8
MGE 100LC-D		3.0	6.2 - 5.0
MGE 112MC-D		4.0	8.1 - 6.6
MGE 132SC-D		5.5	11.0 - 8.8
MGE 132SD-D		7.5	15.0 - 12.0
MMGE 160M		11.0	21.4
MMGE 160MX	3 x 380-415 V	15.0	28.0
MMGE 160L		18.5	34.0
MMGE 180M		22.0	42.0

NBE range 50 Hz 4-pole

Frame size	Voltage	P2 [kW]	I _{1/1} [A]
MGE 90SA-D	3 x 380-480 V	0.75	1.8-1.9
MGE 90SB-D		1.1	2.5 - 2.2
MGE 90LC-D		1.5	3.3 - 2.9
MGE 100LB-D		2.2	4.6 - 3.8
MGE 112LC-D		3.0	6.2 - 5.0
MGE 112MC-D		4.0	8.1 - 6.6
MGE 132SC-D		5.5	11.3 - 10.5
MMGE 160M	3 x 380-415 V	7.5	14.7
MMGE 160M		11.0	21.7
MMGE 160L		15.0	28.5
MMGE 180M		18.5	34.7
MMGE 180L		22.0	41.0

Performance curves

NB 80-160
2-pole

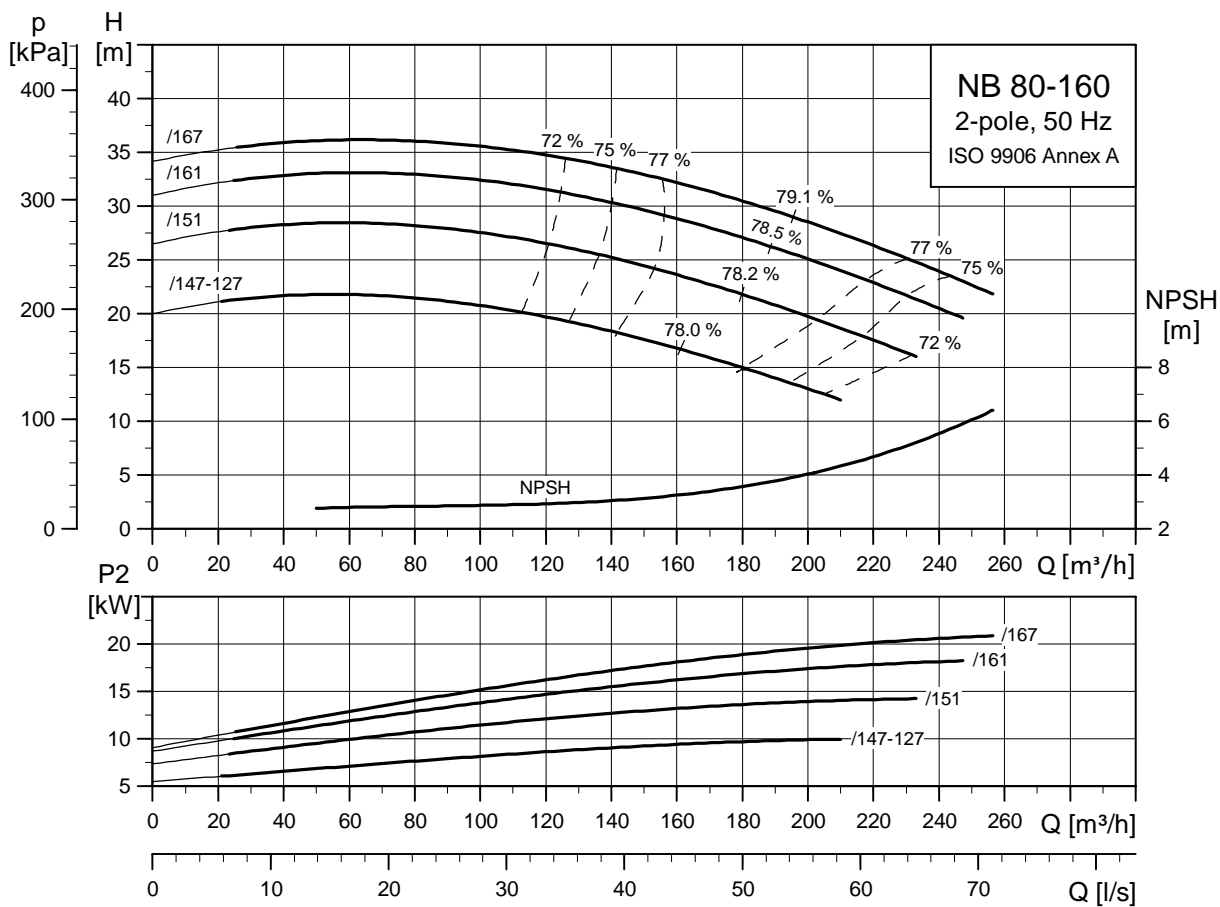

TM03 3235 0606

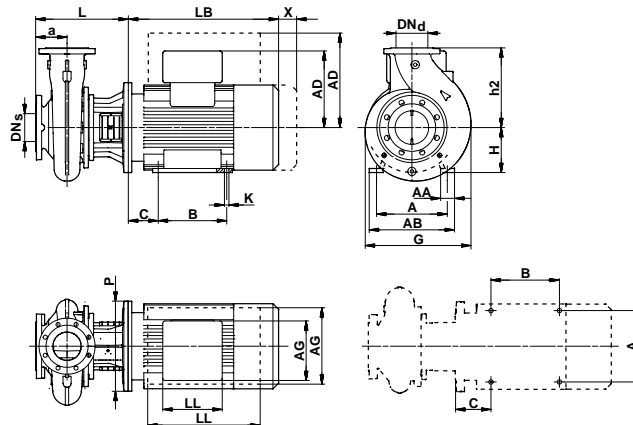

TM01 29207 2104

NB		NB 80-160/147-127	NB 80-160/151	NB 80-160/161	NB 80-160/167
NBE		NBE 80-160/147-127	NBE 80-160/151	NBE 80-160/161	NBE 80-160/167
IEC size	NB ¹⁾	MMG 160MA-E/MMG 160MA-D	MMG 160MB-E/MMG 160MB-D	MMG 160L-E/MMG 160L-D	MMG 180M-E/MMG 180M-D
	NBE	MMGE 160MX	MMGE 160MX	MMGE 160L	MMGE 180M
P2	[kW]	11.0	15.0	18.5	22.0
Design		B	B	B	B
PN	[bar]	PN 16	PN 16	PN 16	PN 16
DN _s	[mm]	100	100	100	100
DN _d	[mm]	80	80	80	80
a	[mm]	125	125	125	125
b	[mm]	-	-	-	-
B ²⁾	[mm]	210/210/210	210/210/210	254/254/254	241/241/241
LB ²⁾	[mm]	505/503/449	505/503/461	560/547/499	590/602/525
P ²⁾	[mm]	350/350/350	350/350/350	350/350/350	350/350/350
C ²⁾	[mm]	108/108/108	108/108/108	108/108/108	121/121/121
G	[mm]	350	350	350	350
H	[mm]	160 ⁵⁾	160 ⁵⁾	160 ⁵⁾	180
h1	[mm]	-	-	-	-
h2	[mm]	225	225	225	225
L	[mm]	368	368	368	368
m1	[mm]	-	-	-	-
m2	[mm]	-	-	-	-
n1	[mm]	-	-	-	-
n2	[mm]	-	-	-	-
s1	[mm]	-	-	-	-
A	[mm]	254	254	254	279
AA ²⁾	[mm]	61/64/55	61/64/55	61/64/55	70/66/62
AB ²⁾	[mm]	320/292/296	320/292/296	320/292/296	355/330/328
K ²⁾	[mm]	15/12/15	15/12/15	15/12/15	15/12/15
AD ²⁾	[mm]	244/244/391	244/244/418	260/241/418	272/285/439
AG ²⁾	[mm]	178/178/296	178/178/296	130/163/296	150/178/328
LL ²⁾	[mm]	162/162/410	162/162/410	162/162/410	186/178/456
X	Motor only	[mm]	110	110	110
	Motor and motor stool	[mm]	140	140	140
NB ⁷⁾	Standard motor range	174/195/0.68	182/203/0.68	205/226/0.68	242/263/0.68
	Premium motor range	142/163/0.68	153/174/0.68	163/184/0.68	192/213/0.68
NBE ⁷⁾	E-motor range	195/204/0.498	269/290/0.872	238/259/0.872	269/291/0.872

- ¹⁾ Frame size of standard range motor/premium range motor.
²⁾ Dimension of pump with standard range motor/premium range motor/E-motor range.
⁵⁾ Attention: P/2 > H.
⁷⁾ Net weight [kg]/gross weight [kg]/shipping volume [m³].