

# NM, NMS

**Close Coupled Centrifugal Pumps with flanged connections**

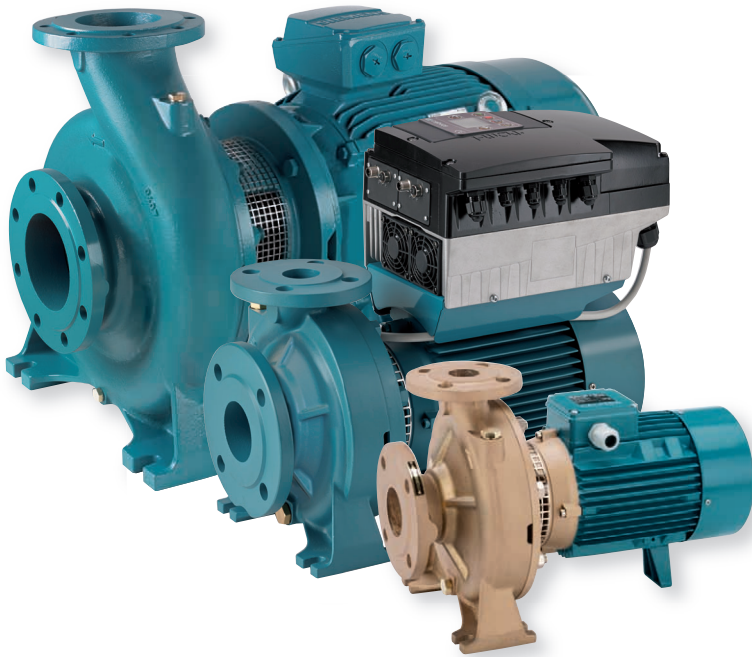

## Construction

Close-coupled centrifugal pumps; electric motor with extended shaft directly connected to the pump up to 22 kW, new bracket construction for standard motors (stub-shaft construction) from 30 to 75 kW with integrated thrust bearing.

Pump casing with axial suction and radial delivery on top, main dimensions and performance according to EN 733.

NM(S): version with pump casing and lantern bracket in cast iron.  
B-NM(S): version with pump casing and lantern bracket/casing cover in bronze. (the pumps are supplied fully painted).

**Connections:** Flanges according to PN 10, EN 1092-2.

**Counter-flanges** (on request)

Sizes	Flanges
from NM 32/.. to NM 50/...	Screwed flanges EN 1092-1, PN 16
from NM 65/.. to NMS 100/...	Flanges for welding EN 1092-1, PN 10

**Version with frequency converter** (on request)

## Applications

For clean liquids without abrasives, which are non-aggressive for the pump materials (solids content up to 0,2%). For water supply.

For heating, air conditioning, cooling and circulation plants.

For civil and industrial applications.

For fire fighting applications. For irrigation.

## Operating conditions

Liquid temperature from -10 °C to +90 °C.

Ambient temperature up to 40° C.

Total suction lift up to 7 m.

Maximum permissible working pressure up to 10 bar (16 bar for NM 32L/16,20; NM 40/16,20; NM 50/12,16; NM 65/12,16,20,25; NM 80/16; NM 100/20).

Continuous duty.

## Motor

2-pole induction motor, 50 Hz ( $n \approx 2900$  rpm).

**NM, NMS:** three-phase 230/400 V  $\pm 10\%$  up to 3 kW;  
400/690 V  $\pm 10\%$  from 4 to 75 kW.

Insulation class F. Protection IP 54 (IP 55 for NMS).

Motor suitable for operation with frequency converter from 1,1 kW.

**Classification scheme IE3 for three-phase motors from 0,75 kW.**

Constructed in accordance with: EN 60034-1; EN 60034-30-1.

## Special features on request

- Other voltages. - Frequency 60 Hz (as per 60 Hz data sheet).
- Protection IP 55.- Special mechanical seal.
- Packed gland (only for NM standard construction).
- Single-phase motor (NMM) up to 1,5 kW.
- Higher or lower liquid or ambient temperatures.
- Motor suitable for operation with frequency converter up to 0,75 kW.

The electropumps NM, B-NM, NMS, B-NMS series comply with the European Regulation no. 547/2012.

## Materials

Components	NM, NMS	B-NM, B-NMS
Pump casing	Cast iron	Bronze
Lantern bracket NM	GJL 200 EN 1561	G-Cu Sn 10 EN 1982
Casing cover for NMS		
Lantern bracket NMS	Cast iron GJL 200 EN 1561	
Impeller	Cast iron	Bronze
	GJL 200 EN 1561	G-Cu Sn 10 EN 1982
	Brass P- Cu Zn 40 Pb 2 UNI 5705 for 32/12, 32/16, 32/20, 32L/20, 40/20	
Shaft	Cr-Ni steel AISI 303	Cr Ni Mo steel
	AISI 430 from 3 kW to 22 kW	AISI 316
Mechanical seal	Carbon - Ceramic - NBR	
Counter-flanges	Steel Fe 430B UNI 7070	

## Coverage chart $n \approx 2900$ rpm

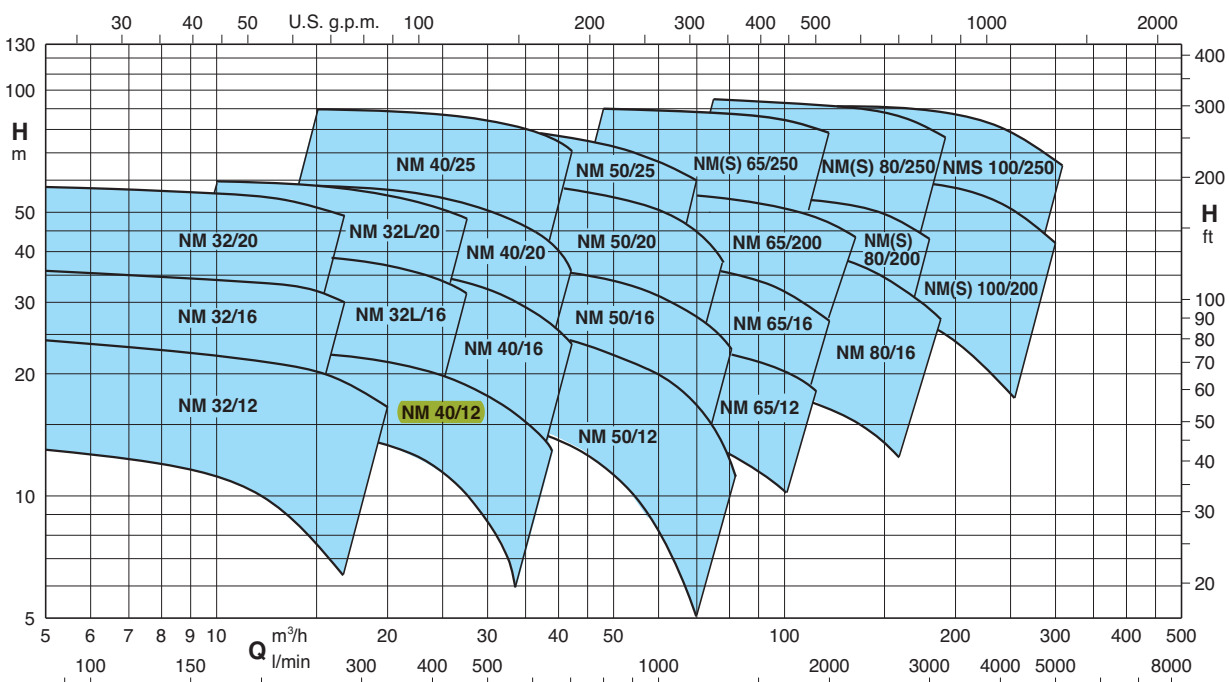

Characteristic curves  $n \approx 2900$  rpm

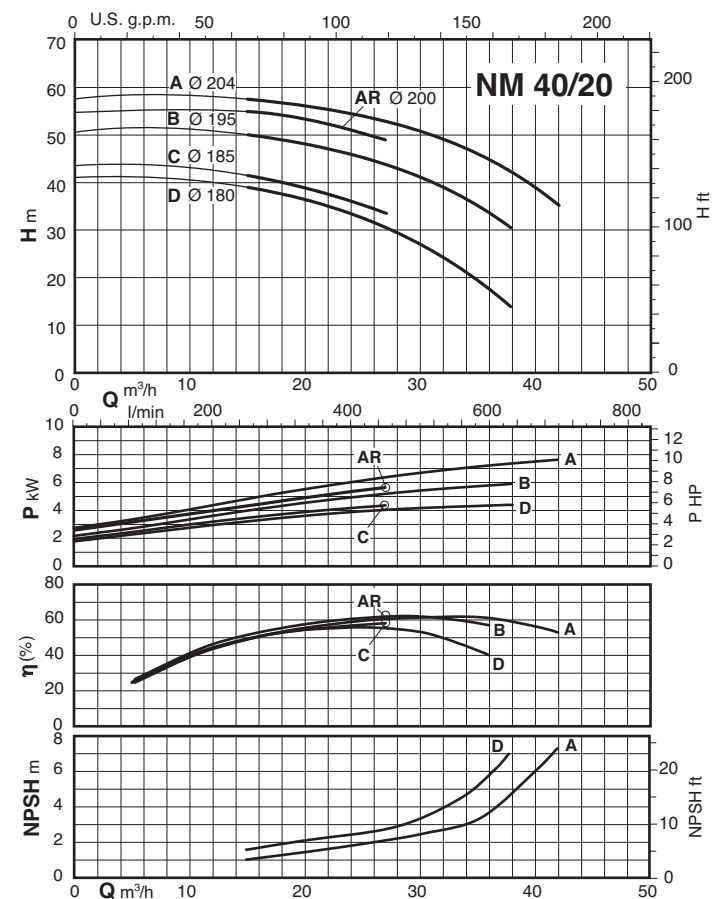
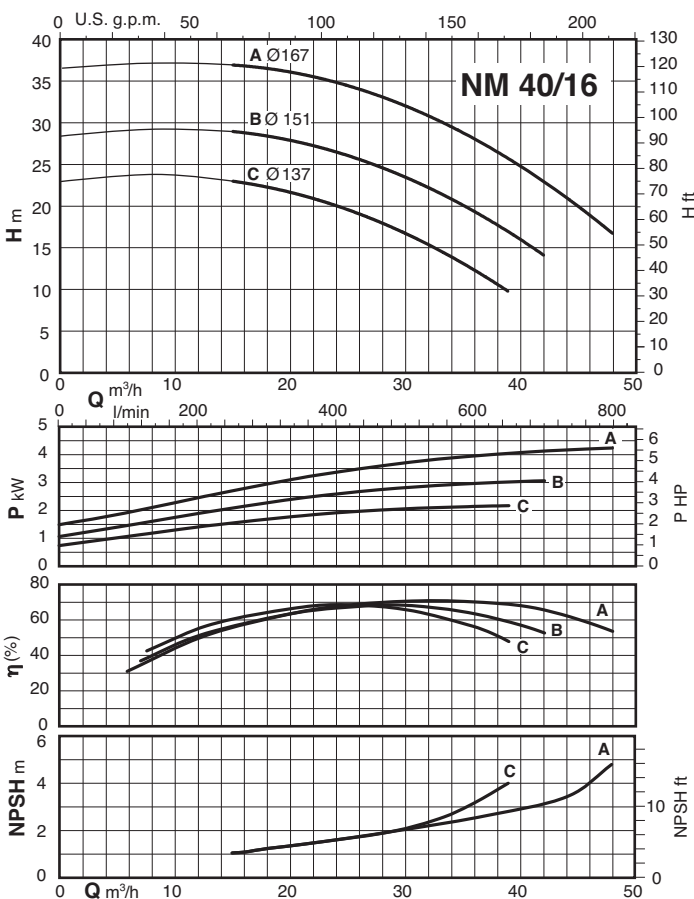
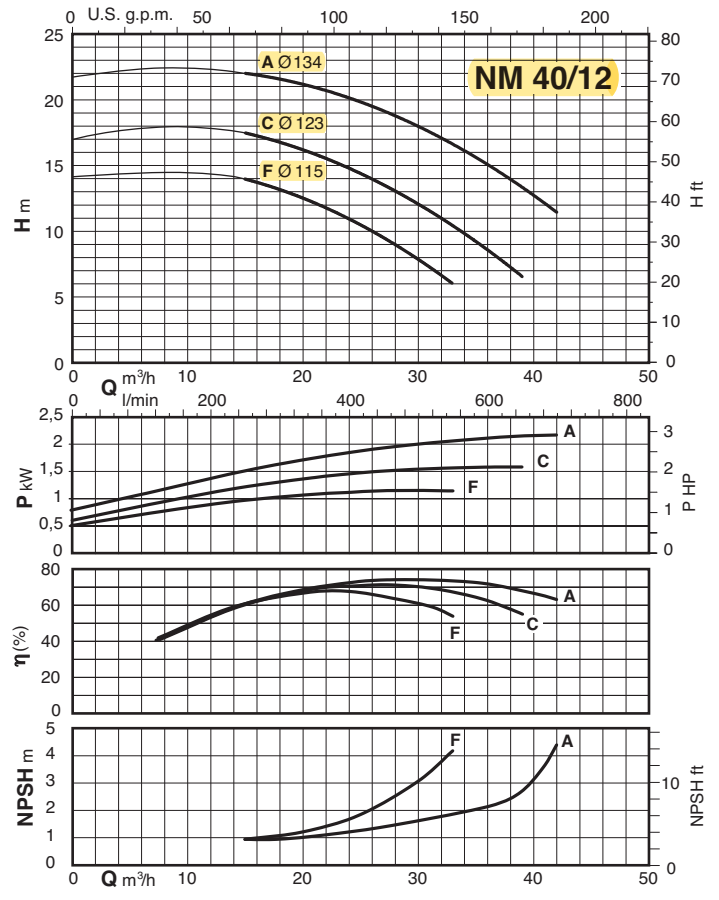
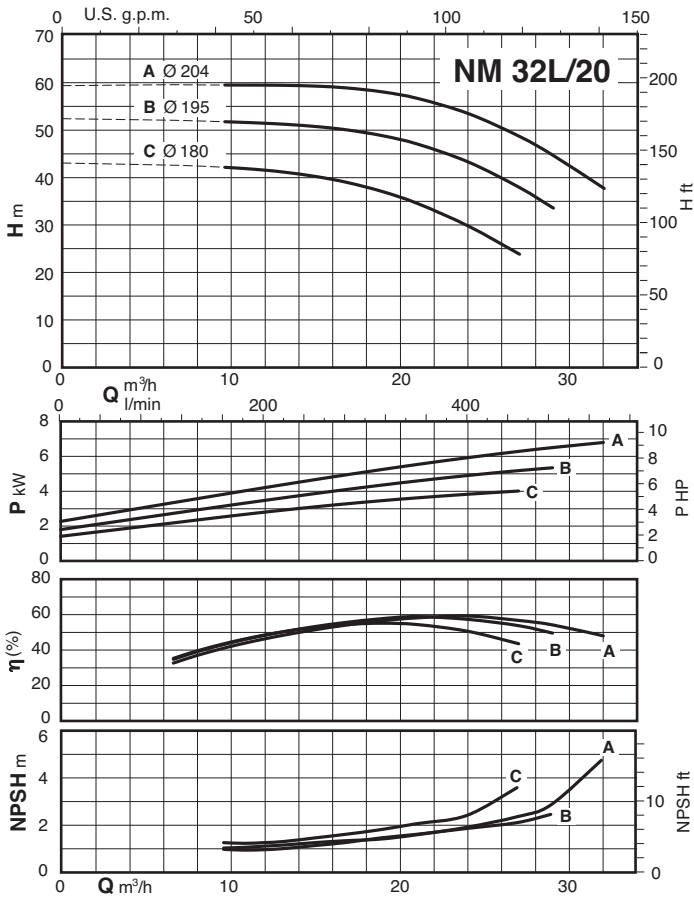

### Dimensions and weights

Flanges EN 1092-2

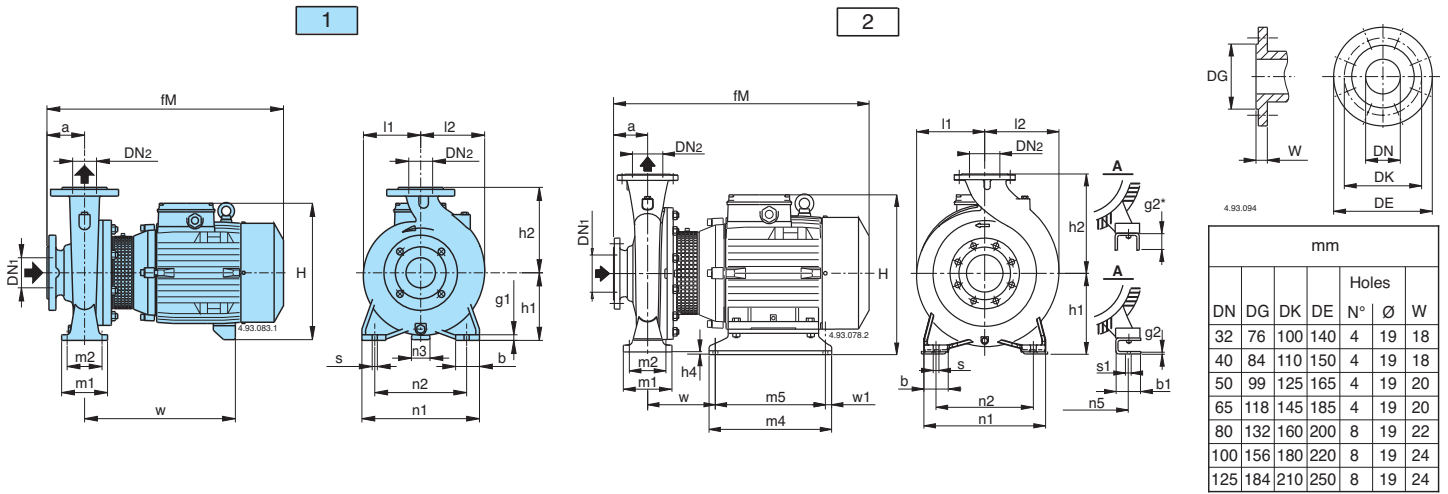

Picture	NM	mm																							kg					
		DN1	DN2	a	fm	h1	h2	H	h4	m1	m2	n1	n2	n3	n5	w1	b	b1	s	s1	l1	l2	w	m4	m5	g1	g2			
1	NM 32/12DE-FE NM 32/12S/A-A/A	50	32	80	405	112	140	240	-	100	70	190	140	37	-	-	50	-	14	-	93	97	245	-	-	12	-	24-24 27-26		
	NM 32/16B/A NM 32/16A/B	50	32	80	410 450	132	160	260	-	100	70	240	190	47	-	-	50	-	14	-	120	120	250 290	-	-	12	-	34 39		
	NM 32/20D/B NM 32/20C/A NM 32/20A/B	50	32	80	450 475 475		180	288 298 298	-	100	70	240	190	62 60 60	-	-	50	-	14	-	140	140	290 295 295	-	-	12	-	42 47 51		
	NM 32L/16C NM 32L/16B NM 32L/16A	50	32	80	450 475 475	132	160	260 270 270	-	100	70	240	190	47 45 45	-	-	50	-	14	-	121	121	290 295 295	-	-	10	-	38,6 45,6 47,6		
	NM 32L/20C NM 32L/20A-B	50	32	80	475 508	160	180	298 320	-	100	70	240	190	60 49	-	-	50	-	14	-	142	142	295 279	-	-	12	-	52 72-66		
	NM 40/12C/B-F/B NM 40/12A/C	65	40	80	410 450	112	140	240	-	100	70	210	160	37	-	-	50	-	14	-	100	113	250 290	-	-	12	-	29-27 32		
	NM 40/16C/C NM 40/16B/B NM 40/16A/C	65	40	80	450 475 475	132	160	260 270 270	-	100	70	240	190	47 45 45	-	-	50	-	14	-	121	122	290 295 295	-	-	10	-	39 46 48		
	NM 40/20C/B-D/B NM 40/20A/A-AR/A-B/A	65	40	100	495 528	160	180	298 320	-	100	70	265	212	60 49	-	-	50	-	14	-	142	142	295 279	-	-	12	-	54-53 73-67-67		
	NM 40/25C/C NM 40/25B/C NM 40/25A/C	65	40	100	640 690 715	180	225	365	-	125	95	320	250	50	-	-	65	-	14	-	175	175	400 460 460	-	-	15	-	108 117 139		
	NM 50/12F/C NM 50/12D/B NM 50/12A/C-S/C	65	50	100	470 495 495	132	160	260 270 270	-	100	70	240	190	47 45 45	-	-	50	-	14	-	122	137	290 295 295	-	-	10	-	40 47 50,5-50,6		
	NM 50/16A/B-B/B	65	50	100	528	160	180	320	-	100	70	265	212	49	-	-	50	-	14	-	126	140	279	-	-	12	-	70,5-64		
	NM 50/20B/C NM 50/20A/C NM 50/20S/C	65	50	100	640 690 720	160	200	345	-	100	70	265	212	40	-	-	50	-	14	-	140	153	400 460 460	-	-	15	-	100 109 131		
	NM 50/25C/C NM 50/25B/C	65	50	100	695 720	180	225	365	-	125	95	320	250	50	-	-	65	-	14	-	175	175	465 465	-	-	15	-	122 145		
	2	NM 50/25A/D	65	50	100	766	180	225	386	-	125	95	320	250	-	254	20	65	60	14	15	175	175	166	394	354	-	20*	-	
	1	NM 65/12E/C NM 65/12A/B-C/B	80	65	100	500 533	160	180	298 320	-	125	95	280	212	60 49	-	-	65	-	14	-	130	154	300 284	-	-	12	-	51,9 70,7-64,7	
		NM 65/16D/B NM 65/16C/C NM 65/16B/C NM 65/16A/C-AR	80	65	100	528 640 690 715	160	200	320 345 345 345	-	125	95	280	212	49 40 40 40	-	-	65	-	14	-	140	161	279 410 410 460	-	-	12	-	70,5 93 112 127	
		NM 65/20C/C	80	65	100	715	180	225	365	-	125	95	320	250	50	-	-	65	-	14	-	159	179	460	-	-	12	-	134	
		2	NM 65/20A/A-B/D	80	65	100	762	180	225	386	-	125	95	320	250	-	254	20	65	60	14	15	159	179	175	394	354	-	20*	--
		NM 65/25C/A	80	65	100	762	202	250	408	2	160	120	360	280	-	254	20	80	90	18	14	179	185	182	400	360	-	42*	187	
	1	NM 80/16E/B NM 80/16D/C NM 80/16C/C NM 80/16B/C	100	80	125	553 670 720 745	180	225	340 365 365 365	-	125	95	320	250	60 50 50 50	-	-	65	-	14	-	153	181	279 415 465 465	-	-	12	-	77,5 101 120 132	
2		NM 80/16A/D	100	80	125	789	180	225	386	-	125	95	320	250	-	254	20	65	60	14	15	153	181	164	394	354	-	20*	-	
NM 80/20B		100	80	125	787	202	250	408	22	125	95	345	280	-	254	20	65	90	18	14	170	194	182	400	360	-	42*	180		
NM 80/25E		100	80	125	787	202	280	408	2	160	120	400	315	-	254	20	80	90	18	14	191	210	182	400	360	-	42*	193		
2	NM 100/20D-E/A	125	100	125	787	200	280	406	-	160	120	360	280	-	254	20	80	90	18	15	180	212	162	394	354	-	40*	--		

Pumps with packed gland, dimensions available on request (excluded NMS).

### Features

#### Cutting edge hydraulics

The geometry of the impeller and the pump casing are optimized to achieve maximum efficiency and the best suction capability.

#### Flexible

The option to choose between cast iron and bronze materials for the hydraulic parts in contact with the pumped liquid allows NM series pumps to be selected for use with different types of liquids.

#### Compact Design

The compact design allows for easy installation even in confined spaces.

#### Exclusive design

An innovative, patented guard prevents contact with rotating parts, proving protection to the end user whilst allowing for inspection of the mechanical seal.

#### Reliable

The bearing and shaft are designed to ensure the reduction of the stress, providing high reliability under all operating conditions.

NM

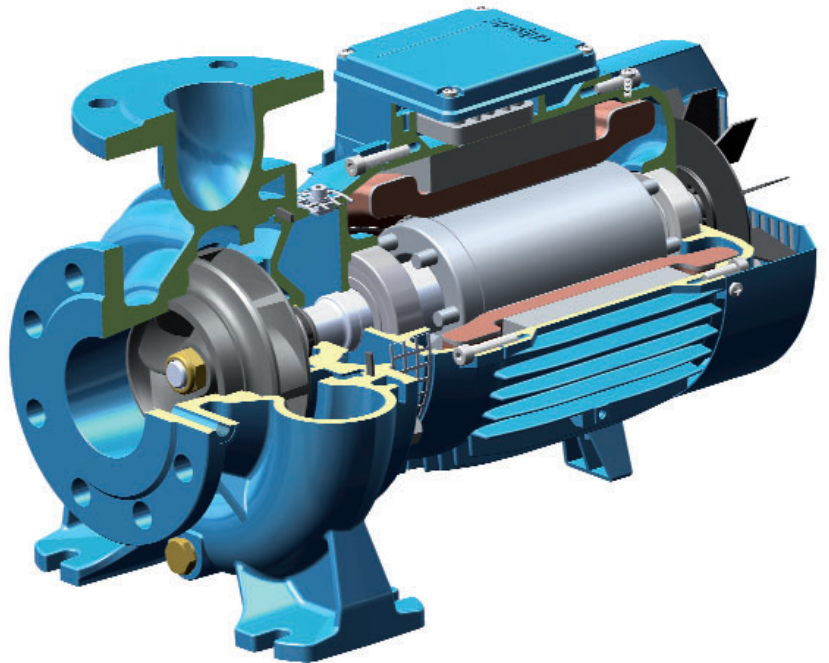

#### Cutting edge hydraulics

The geometry of the impeller and the pump casing are optimized to achieve maximum efficiency and the best suction capability.

#### Flexible

The option to choose between cast iron and bronze materials for the hydraulic parts in contact with the pumped liquid allows NMS series pumps to be selected for use with different types of liquids.

#### New lantern bracket construction

The lantern brackets incorporate a thrust bearing on the hydraulic side which guarantees the elimination of additional loads on the motor bearings. The flange is sized to be used with standard motors B35.

#### Exclusive design

An innovative, patented guard prevents contact with rotating parts, proving protection to the end user whilst allowing for inspection of the mechanical seal.

#### Simplified motor maintenance

The presence of the thrust bearing on the hydraulic side makes it easier to remove the motor, facilitating maintenance operations and eliminating the risks of damage to the hydraulic parts.

NMS

