

Száraztengelyű szivattyúk

Inline szivattyúk



Wilco-DPn 65/180-1,5/4... Wilco-DPn 65/250-4/4 – fordulatszám 1450 1/min

Jelleggörbék – egyes üzem

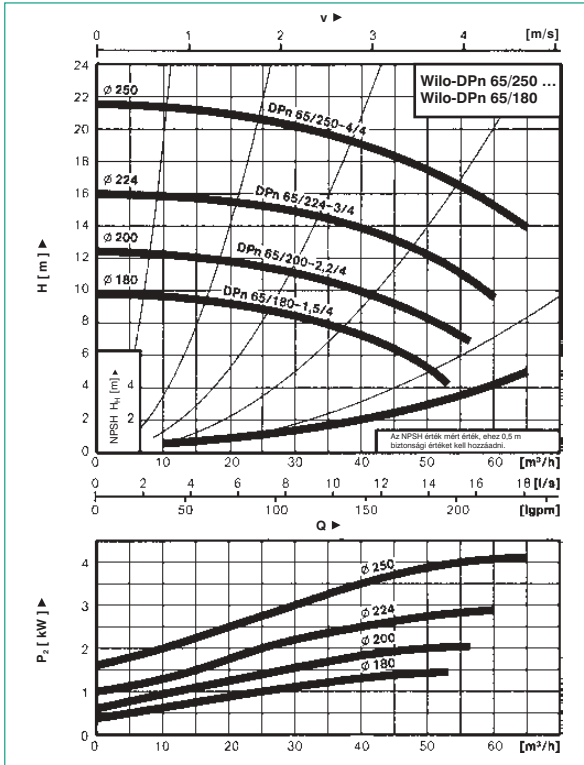

Jelleggörbék – párhuzamos üzem

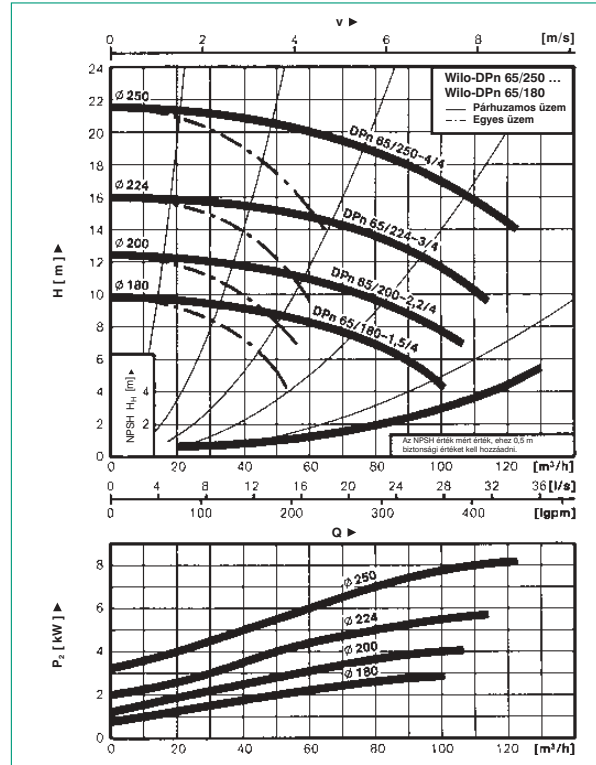

Méretrajz

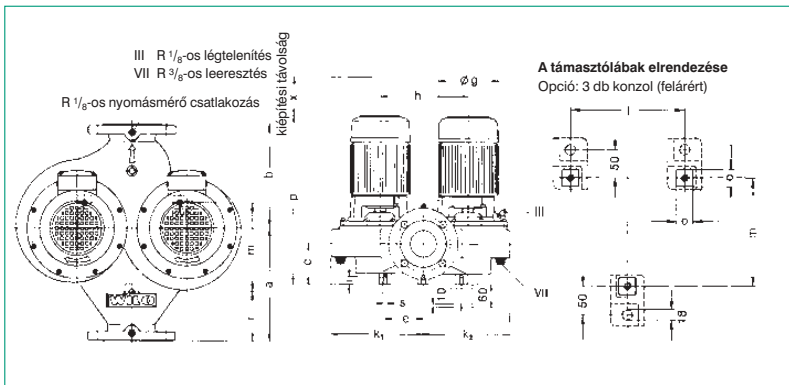

Méreték – tömegek

Wilco-DPn	DN	mm																Töm. kb. kg
		a	b	c	e	g	h	i	k ₁	k ₂	l	m	o	p	r	s	x	
DPn 65/180-1,5/4	65	210	265	119	165	176	330	15	337	328	330	231	30	501	18	M 10	120	130
DPn 65/200-2,2/4	65	210	265	119	165	196	330	15	337	328	330	231	30	521	18	M 10	120	134
DPn 65/224-3/4	65	210	265	119	165	196	330	15	337	328	330	231	30	521	18	M 10	120	138
DPn 65/250-4/4	65	210	265	119	165	220	330	15	337	328	330	231	30	535	18	M 10	120	150

Karima méretek

Karima PN 16 - EN 1092-2 sz. furatokkal				
DN	D	d	k	n x d _L
	mm			db x mm
65	185	122	145	4 x 19

n = a furatok száma

Kapcsolási vázlat

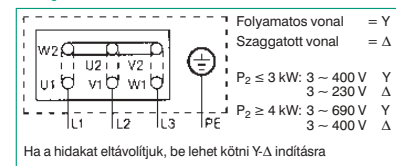

Motoradatok ford. szám 1450 1/min

Wilco-DPn	Névl. teljesítmény P ₂ kW	Névl. áram I _{N3} ~ 400 V kb. A	η ₃	cos φ	Telj. tényező	Motor. hatások	Tengely-egység
DPn 65/180-1,5/4	1,5	3,5	0,82	0,75	18		18
DPn 65/200-2,2/4	2,2	4,8	0,85	0,78	18		18
DPn 65/224-3/4	3,0	6,6	0,84	0,79	18		18
DPn 65/250-4/4	4,0	8,8	0,82	0,82	18		18

Ügyeljünk a motor adattábla adataira!