

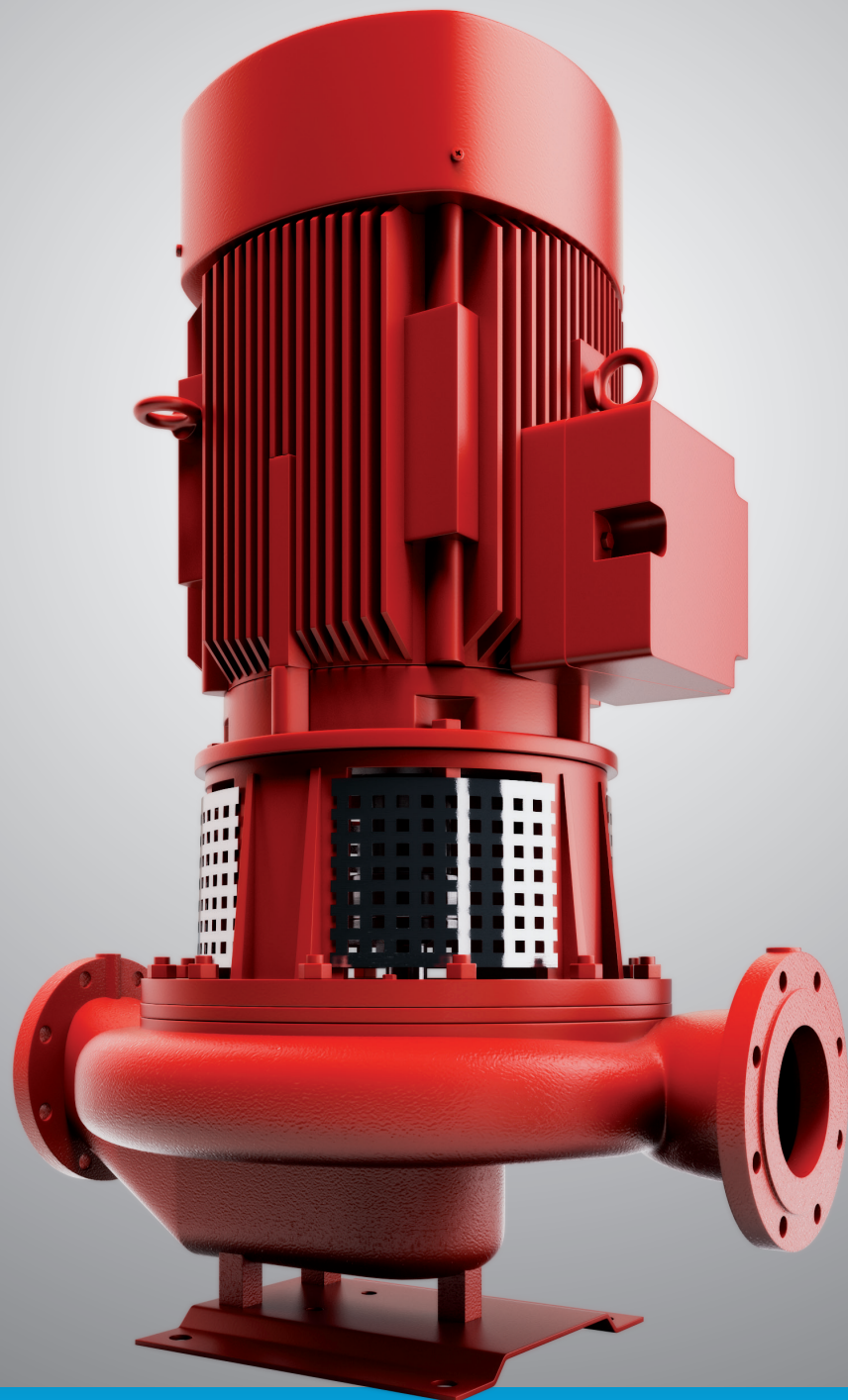

KOLMEKS

INLINE SD-PUMPS
WITH IEC-STANDARD MOTOR





KOLMEKS
TEHOKASTA LUOTETTAVUUTTA

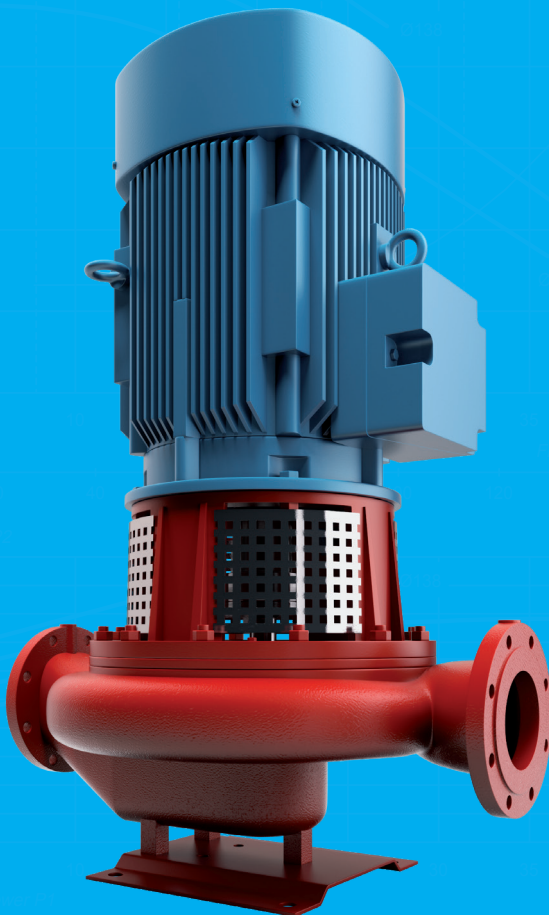

INLINE SD- PUMPS
WITH IEC-STANDARD MOTOR
L_-ja AL_-series, flanged DN100 - DN250

General technical data

Inline SD- pumps with IEC- standard motor L_ and AL_- series pumps

- Inline centrifugal pumps equipped with flange connections.
- Pumps can be used as circulation, pressure boosting and transfer pumps for clean liquids.

Applications:

- Grey cast iron (L- and AL) pumps can be used as circulation, pressure boosting and transfer pumps for clean liquids.
- Nodular cast iron (LH and ALH) pumps can be used in power plants and as pressure boosting pumps for primary district heating.
- Bronze (LP and ALP) pumps can be used as domestic hot water, circulation, pressure boosting and transfer pumps for clean oxygen-rich and some slightly aggressive liquids.
- Stainless steel AISI316 (LS and ALS) pumps can be used as circulation, pressure boosting and transfer pumps for acid and alkaline liquids.

Note! The suitability of materials and seals for the liquid to be pumped must always be confirmed when selecting a pump.

Quick Selection Chart for SD-pumps with IEC- standard motor, L- and AL-series, 50Hz

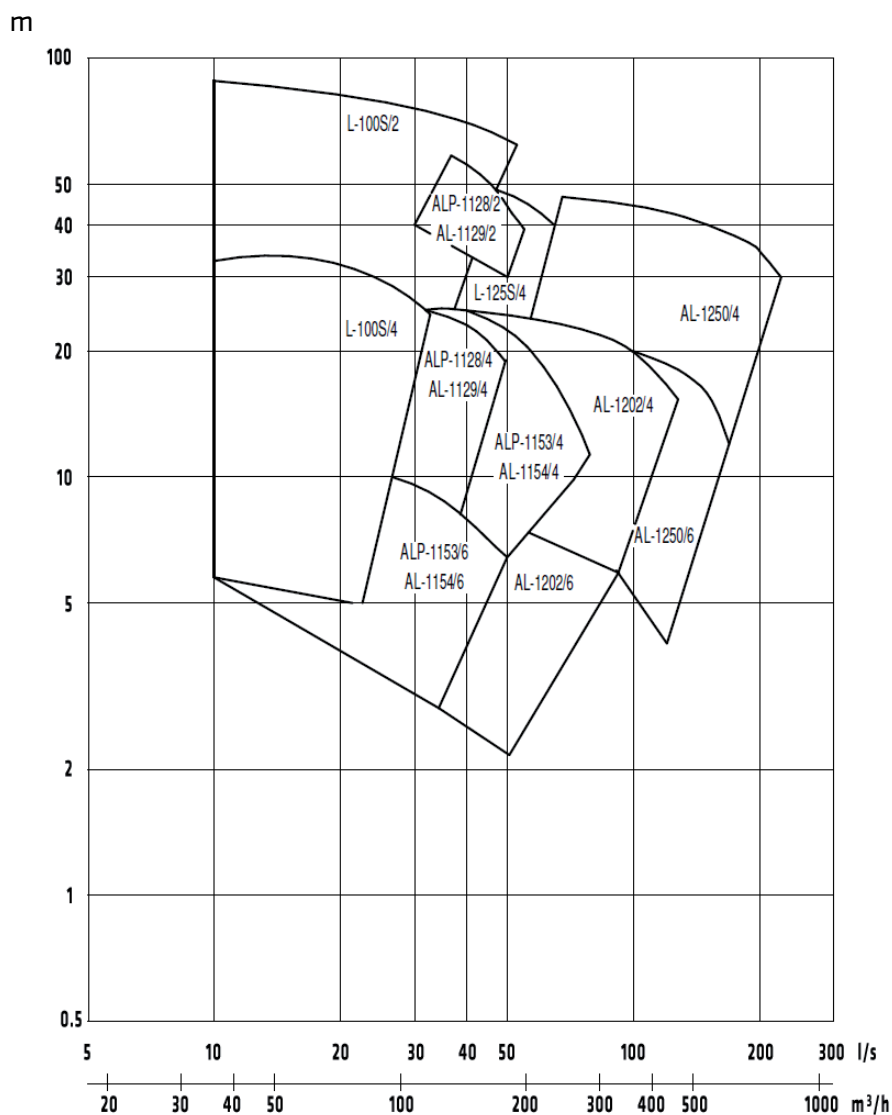

Quick Selection Chart for SD-pumps with IEC- standard motor, L- and AL-series, 60Hz

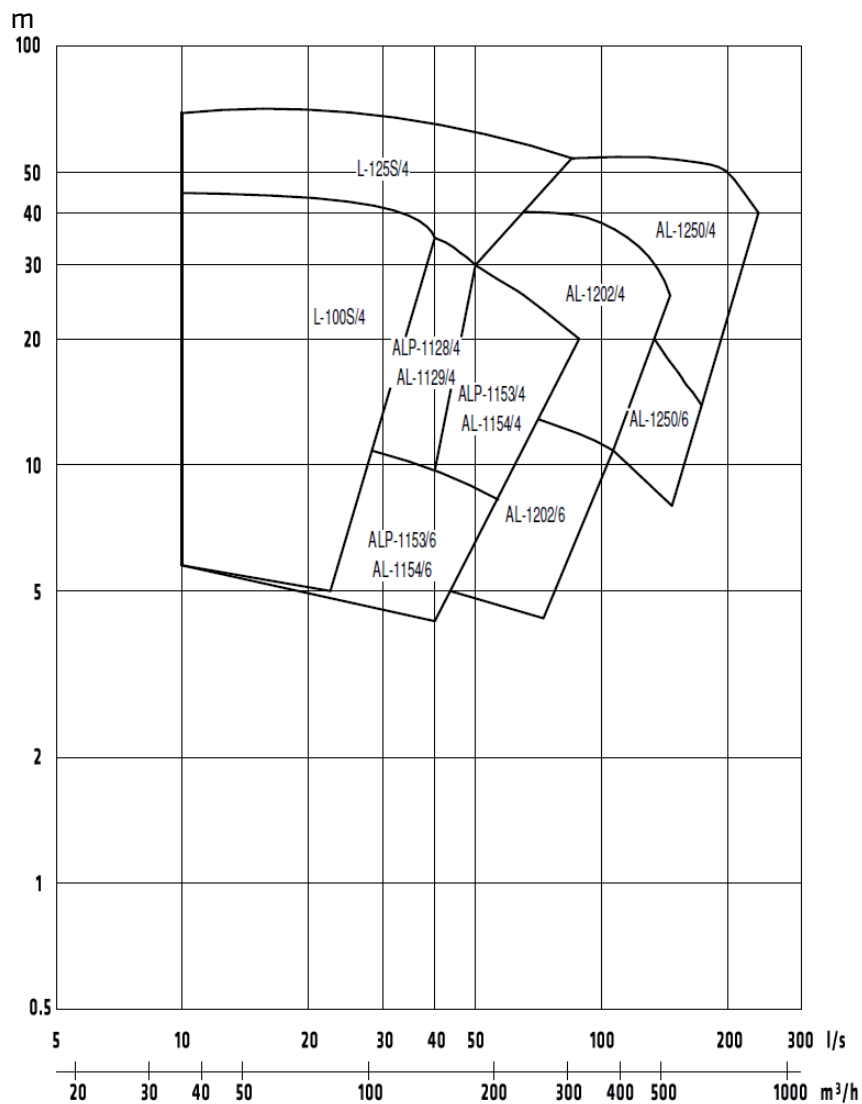

Standard materials and fields of application for SD-pumps L_ and -AL_-series

Connection	Grey cast Iron EN-GJL-200, PN10	Nodular cast iron EN-GJS-400, PN16	Bronze CuSn10Zn2, PN10	Stainless steel AISI 316, PN 16	Stainless steel SS 2378-254 SMO	Shaft seal, PN10 Ø [mm], materials	O-ring size [mm]	O-ring material	Motor [kW]
DN 100	L-100S/4 SD	LH-100S/4 SD	LP-100S/4 SD	-	-	32, carbon/SiC EPDM	315 x 6,3	EPDM	3-22
	L-100S/2 SD	LH-100S/2 SD	LP-100S/2 SD	-	-	32, carbon/SiC EPDM	315 x 6,3	EPDM	15-37
	L-100S/2 SD	LH-100S/2 SD	LP-100S/2 SD	-	-	40, carbon/SiC EPDM	315 x 6,3	EPDM	45
DN 125	AL-1129/4 SD	ALH-1129/4 SD	-	ALS-1129/4 SD	ALM-1129/4 SD	32, carbon/SiC EPDM	309/295X1	gasket	3-22
	AL-1129/2 SD	ALH-1129/2 SD	-	ALS-1129/2 SD	ALM-1129/2 SD	32, carbon/SiC EPDM	309/295X1	gasket	30-37
	-	-	ALP-1128/4 SD	-	-	32, carbon/SiC EPDM	309/295X1	gasket	3-22
	-	-	ALP-1128/2 SD	-	-	32, carbon/SiC EPDM	309/295X1	gasket	30-37
	L-125S/4 SD	LH-125S/4 SD	-	LS-125S/4 SD	-	40, carbon/SiC EPDM	405 X 7	EPDM	18,5-37
L-125S/4 SD	LH-125S/4 SD	-	LS-125S/4 SD	-	50, carbon/SiC EPDM	405 X 7	EPDM	45-55	
DN 150	-	-	ALP-1153/6 SD	-	-	32, carbon/SiC EPDM	309/295X1	gasket	5,5-11
	-	-	ALP-1153/4 SD	-	-	32, carbon/SiC EPDM	309/295X1	gasket	4-30
	AL-1154/6 SD	ALH-1154/6 SD	-	ALS-1154/6 SD	ALM-1154/6 SD	32, carbon/SiC EPDM	309/295X1	gasket	5,5-11
	AL-1154/4 SD	ALH-1154/4 SD	-	ALS-1154/4 SD	ALM-1154/4 SD	32, carbon/SiC EPDM	309/295X1	gasket	4-30
DN 200	AL-1202/6 SD	ALH-1202/6 SD	ALP-1202/6 SD	ALS-1202/6 SD	ALM-1202/6 SD	32, carbon/SiC EPDM	315 x 6,3	EPDM	4-11
	AL-1202/6 SD	ALH-1202/6 SD	ALP-1202/6 SD	ALS-1202/6 SD	ALM-1202/6 SD	40, carbon/SiC EPDM	315 x 6,3	EPDM	15-18,5
	AL-1202/4 SD	ALH-1202/4 SD	ALP-1202/4 SD	ALS-1202/4 SD	ALM-1202/4 SD	32, carbon/SiC EPDM	315 x 6,3	EPDM	15-18,5
	AL-1202/4 SD	ALH-1202/4 SD	ALP-1202/4 SD	ALS-1202/4 SD	ALM-1202/4 SD	40, carbon/SiC EPDM	315 x 6,3	EPDM	22-37
	AL-1202/4 SD	ALH-1202/4 SD	ALP-1202/4 SD	ALS-1202/4 SD	ALM-1202/4 SD	50, carbon/SiC EPDM	315 x 6,3	EPDM	45
DN 250	AL-1250/6 SD	ALH-1250/6 SD	-	ALS-1250/6 SD	-	40, carbon/SiC EPDM	405 X 7	EPDM	15-22
	AL-1250/6 SD	ALH-1250/6 SD	-	ALS-1250/6 SD	-	50, carbon/SiC EPDM	405 X 7	EPDM	30
	AL-1250/4 SD	ALH-1250/4 SD	-	ALS-1250/4 SD	-	40, carbon/SiC EPDM	405 X 7	EPDM	37
	AL-1250/4 SD	ALH-1250/4 SD	-	ALS-1250/4 SD	-	50, carbon/SiC EPDM	405 X 7	EPDM	45-55
AL-1250/4 SD	ALH-1250/4 SD	-	ALS-1250/4 SD	-	65, carbon/SiC EPDM	405 X 7	EPDM	75-90	

SERIES	Pressure class / temperature [°C]	Housing material Name	Marking	Sealing flange	Impeller	Pump shaft	Difference in materials
L / AL	PN10 / -15...+120	grey cast iron	EN-GJL-200	EN-GJL-200	EN-GJL-200	AISI329	Bronze impeller available to all pumps On special request also SS2324 (AISI 329) ja SS2378 "SMO" (LM / ALM-pumps)
LH / ALH	PN16 / -15...+180 (depending on seal construction)	nodular cast iron	EN-GJS-400	EN-GJS-400	EN-GJL-200	AISI329	
LP / ALP	PN10 / -15...+120	bronze	CuSn10Zn2	CuSn10Zn2	CuSn10Zn2	AISI329	
LS / ALS	PN16 / -15...+180 (depending on seal construction)	stainless steel	AISI316	AISI316	AISI316	AISI329	

Standard shaft material is Stainless steel AISI 329. In LM / ALM-pumps shaft material is Stainless steel SMO, SS2378.

Structure

SD-pump

L- and AL-series pumps are monoblock centrifugal pumps equipped with IEC- standard motor

IEC- standard electric motor

The electric motor of L and AL series SD- pump is a IEC- standard asynchronous motor designed specifically for pump use. The electric motor is highly efficient and has low noise levels. The electric motor is suitable for frequency converter use.

Standard voltages: 690/400 V, 50 Hz 4-90 kW

660/380 V, 60 Hz 4-90 kW

690/400 V, 60 Hz 4-90 kW

440 V, 60 Hz 4-105 kW

460 V, 60 Hz 4-110 kW

480 V, 60 Hz 4-110 kW

Note! In the data sheets, value of the nominal currents are indicated as approximate values for 400 V, 50 Hz ja 380-480 V, 60 Hz.

The exact values depend on the motor type, efficiency class and brand of motor. That exact values are informed in the order confirmation and motors rating plate.

Enclosure class: IP55

Insulation class: F

Duty type: S1 (continuous duty)

Ambient temperature: max. +40°C

NOTE! The IEC- standard electric motors are available in other enclosure classes and voltages by request.

Connections

The L- and AL-series pumps are equipped with flanged connections (PN10 or PN16) according to ISO 7005.

Flanges to ANSI/JIS standards are available by request.

Seals

The standard shaft seal on L- and AL-series pumps is a single mechanical seal. The pump housing seal is an O-ring or flat gasket.

By request, there are several seal materials and structure alternatives available depending on the properties and temperature of the liquid.

Standard surface treatment

All parts of the pumps and motor brackets are painted according to Standard SFS-EN ISO 12944-5, AY80/2 FcSa2. The color is RAL3020.

The IEC standard motors are painted according to the motor manufacturers standards with their original standard paint and colour. The exact paints and colours depend on the motor supplier and the brand of the motor.

Special surface painting

Epoxy surface treatment and colour alternatives are available by request.

Type markings
Rating plate for pump

Material:
P = Bronze
H = Nodular Cast Iron
S = Stainless steel AISI316

Flange DN-size

Pole number of motor:
2: 3000r/min 50Hz
3600r/min 60Hz
4: 1500r/min 50Hz
1800r/min 60Hz
6: 1000r/min 50Hz
1200r/min 60Hz

Accessories:
T = External shaft seal
H = Internal or external flushing
KT = Double shaft seal
Sn = Non-standard shaft seal
Kn = Non-standard surface treatment

Type of pump	Pump ALH-1202/4H SD					1403	
Manufacturing number and -year	No 123456.10 2014 PN16					Ø 315 mm	
Duty point and max temperature of the liquid	100 l/s 25 m		+150 °C P2N		37 kW		
Minimum efficiency index (MEI)	MEI ≥ 0,1 --				400 V / 50 Hz		

Manufacturing year and month
Pressure class and impeller diameter and non-standard material of impeller:
PM = Bronze
SS = Stainless steel AISI316
Nominal power of motor
Nominal principal voltage of electrical network/frequency

Rating plate for motor

	IE2 						
Motor type	3~ motor M3AA 225 SMA 4					2014	
	No.					Ins.cl F	IP 55
Nominal voltages frequencies and powers	V	Hz	kW	r/min	A	cos φ	Duty
	400 D	50	37	1479	68,0	0,84	S1
	690 Y	50	37	1479	39,4	0,84	S1
	415 D	60	37	1481	68,0	0,81	S1
	460 D	60	37	1782	59,0	0,84	S1
Efficiency class of electric motor	50Hz: IE2 - 93.4(100%) - 93.8(75%) - 93.1(50%) 60Hz: IE2 - 93.6(100%) - 93.5(75%) - 92.5(50%)						
Bearing types	D.E. 6313-2Z/C3		N.D.E 6212-2Z/C3		240 kg		
	IEC 60034-1						

Year of manufacture
Insulation- and enclosure class
Rotation speed, nominal currents, cos φ
Continuous duty
Weight of motor

Seal structure alternatives

Standard structure

- Single mechanical seal
- Max. operating temperature +120 °C.

The standard-construction shaft seal can also be used for water-glycol mixtures and most other indirect refrigeration systems. The recommended glycol is propylene glycol with a concentration of up to 50%. Most often, a concentration of 30–40% is adequate.

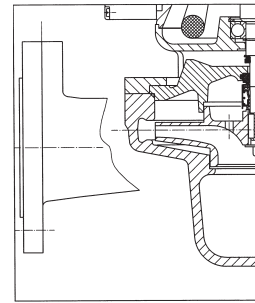

Internal flushing

- Single mechanical seal
- Recirculation from the discharge flange of the pump to the seal chamber which flushes the seal
- Max. +150 °C water
- Available for flange sizes DN50 ... DN300. . This is indicated with an additional marking 'H' in the pump type e.g. LS-125S/4 SD H.

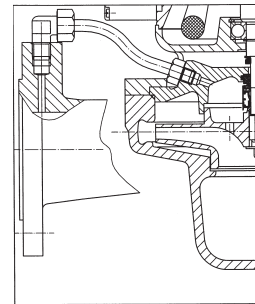

External flushing

- Single mechanical seal
 - A pipe from an external source plugged to the seal chamber which makes it possible to flush the seal with external pressure if required
 - Available for pumps in flange sizes DN 50–300
 - Crystallising and accumulative liquids
- This is indicated with an additional marking 'H' in the pump type e.g. LS-125S/4 SD H.

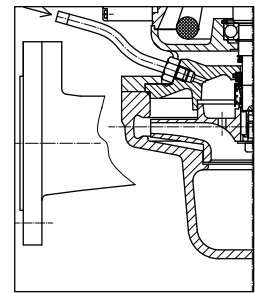

External seal

- Externally-mounted single mechanical Teflon bellows
- Available for flange sizes DN 65–300 ALS pumps
- Extremely corrosive liquids, e.g. sulfuric acid
- Marking 'T' in the pump type e.g. ALS-1106/4 SD T
- NOTE! Maximum working pressure 10 bar

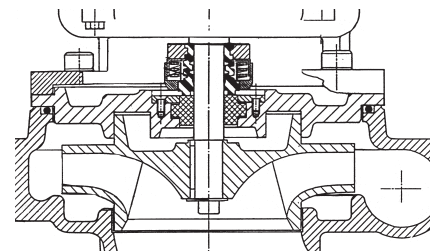

Double mechanical seal system (cartridge)

- Two opposing seals with sealing liquid brought from outside (circulation). The pressure of the liquid can be lower or higher than that of the liquid being pumped
- Available for flange sizes DN 65–300 pumps
- Max. operating temperature +180°C for water
- Requires a separate seal water monitoring unit (available from Kolmeks)
- Marking 'KT' in the pump type e.g. ALS-1154/4 SD KT
- Hot, crystallizing and accumulative liquids

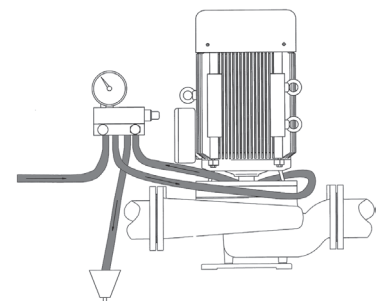

Installation

Ensure the following when installing the pump:

- Enough room for service and inspection
- Possibility to use lifting and transfer devices if required
- Shut-off valves on both sides of the pump, allowing the position of the motor unit and the electrical terminal connection box to be changed by removing the motor unit from the pump housing and by installing it in the required position (not applicable when using internal seal flushing, marking 'H' which is standard in the LH/ALH series)

Kolmeks Inline SD-pumps are installed always on a base plate and vertical position.

When selecting a method of installation, please consider at least the following:

- Enough room for installation and service
- Strength, rigidity and support of the piping
- Vibration and noise level requirements

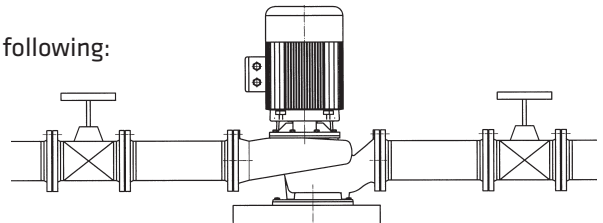

Kolmeks Inline SD- pumps are always fastened by their base plate onto a freely moving concrete plinth, which is separated from the floor by a 20-mm thick rubber or cork mat for example. The weight of the concrete base must be about 1.5 times the weight of the pump.

Spare parts and service for SD-pumps

Parts list

- | | |
|-----------|--------------------------------|
| 1 | Electric motor |
| 2 | Pump housing |
| 3 | Impeller |
| 5 | Sealing flange |
| 8 | Base plate |
| 14 | Coupling |
| 21 | Flange-shaft |
| 22 | Screw |
| 24 | Screw |
| 25 | Washer |
| 40 | Mechanical shaft seal |
| 50 | O-ring or gasket |
| 60 | Screw / Nut |
| 62 | Screw |
| 67 | Screw |
| 70 | Screw / Nut |
| 73 | Screw |
| 80 | Pipe joint (ALH- ja LH-series) |
| 81 | Pipe joint (ALH- ja LH-series) |
| 86 | Pipe (ALH- ja LH-series) |
| 89 | Washer |
| 92 | Coupling protection |

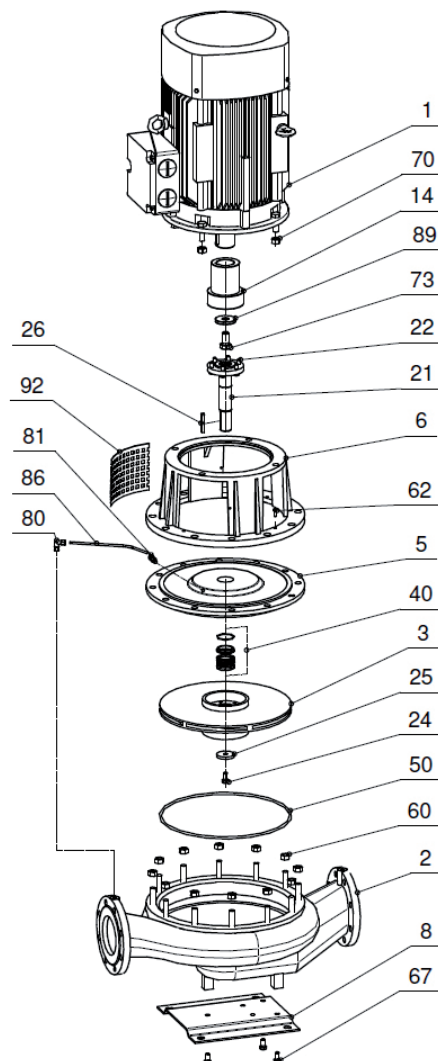

Drive unit

The drive unit is a new stand-by operation unit which includes:

- 1) Motor
- 2) Sealing flange
- 3) Impeller
- 4) Seals

If a motor malfunction or a seal leak occurs, replacing the motor unit is simple and quick and does not require long periods of stoppage. No procedures need to be carried out on the piping, because there is no need to detach the pump housing

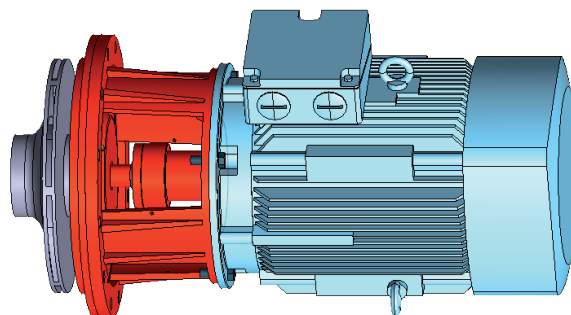

Shaft seal

If a seal leak occurs in a new pump, e.g. during commissioning, it is possible to replace only the shaft seal with a new one.

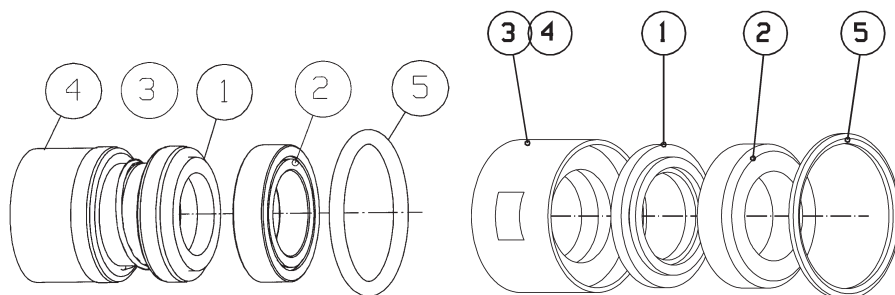

Parts of single mechanical shaft seal

- | | |
|---|-----------------|
| 1 | Rotating ring |
| 2 | Stationary ring |
| 3 | Body/bellows |
| 4 | Spring |
| 5 | O-ring |

Reading curves and selecting a pump

AL_-1250/4 SD DN250

Selecting a fixed speed pump from 50 Hz pump curve (curves on the left)
 E.g. duty point: flow = 160 l/s, head = 35 m, liquid: water +20°C.

1. Use the quick selection chart at the beginning of the catalogue or browse through the product catalogue in order to find a pump of the correct size range such that the required flow 160 l/s is at the best efficiency point ($\eta = 80\%$).

2. Select the impeller size [$\varnothing = \text{mm}$] from the QH curve by drawing a vertical line through the point of 160 l/s flow and, equivalently, a horizontal line through the point of 35m head.

3. Find the impeller size at the intersection = 380 mm. Note! If the intersection falls between two impeller sizes, the impeller diameter is selected halfway between the two sizes.

4. Read the nominal shaft power of the motor from the section in which the QH curve is.
 In this example, the motor nominal shaft power is $P_2N = 75 \text{ kW}$.
 According to the shaft power P_2 , $P_2 = 71 \text{ kW}$, the motor nominal power becomes $P_2N = 75 \text{ kW}$ (the closest highest motor nominal power).

5. Check the nominal current of the electric motor from the column on the right-hand side of the nominal power column in the table, $IN = 133.9 \text{ A}$. Select an overload protection for the motor according to nominal current.

6. Read the pump weight from the same table [kg] = 900 kg.

7. For energy calculation, read the electrical power of the device = P_1 [kW], from the P_1 curve with a required flow of $Q = 160 \text{ l/s}$ and at the point of the selected impeller size, $\varnothing = 380 \text{ mm}$.
 In this example, the device electrical power is $P_1 = 74 \text{ kW}$.

8. Energy cost = Electrical power P_1 [kW] x energy price [€/ kWh] x operating time [h].

Characteristic curves apply to +20°C water.

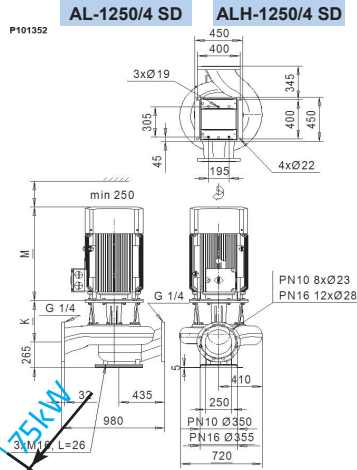

IEC-standard motor IM V1

Motor 400V	P_{2N} [kW]	I_N [A]	[kg]	M [mm]	K [mm]
IEC-225	37	68	620	740	408
IEC-225	45	81	640	740	408
IEC-250	55	99	690	750	428
IEC-280	75	134	900	950	428
IEC-280	90	159	940	950	428
Motor 380-400V(460-480V)	P_{2N} [kW]	I_N [A]	[kg]	M [mm]	K [mm]
IEC-225	45 (54)	81	640	740	408
IEC-250	55 (66)	99	690	750	428
IEC-280	75 (90)	134	900	950	428
IEC-280	90 (105)	159	940	950	428

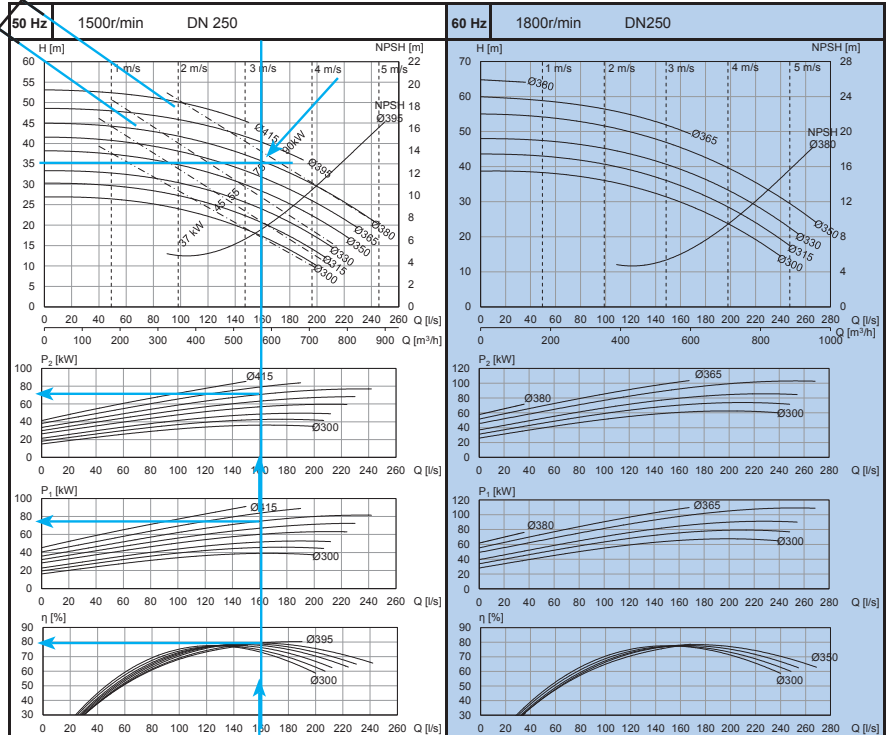

Note! Please contact Kolmeks for additional information on the following issues!

- When pumping liquids whose viscosity differs from that of water, the effect of viscosity must be considered in pump selection.
- Liquid density is directly proportional to the power requirement. The sufficiency of motor power must be checked for liquids denser than water.

Selecting an optimal pump for frequency converter operation from a 60Hz curve

CORRECTLY-SIZED PUMP

AL-1154/4 SD ALH-1154/4 SD ALS-1154/4 SD

IEC-standard motor IM V1

Motor 400V	P_{2N} [kW]	I_{LN} [A]	[kg]	M [mm]	K [mm]
IEC-132	5.5	11	210	490	254
IEC-132	7.5	15	220	490	254
IEC-160	11	21	280	580	302
IEC-160	15	28	290	580	302
IEC-160	18.5	35	320	620	302
Motor 380-400V(460-480V)	P_{2N} [kW]	I_{LN} [A]	[kg]	M [mm]	K [mm]
IEC-132	5.5 (6.6)	11	210	490	254
IEC-132	7.5 (9)	15	220	490	254
IEC-160	11 (13)	21	280	580	302
IEC-160	15 (18)	28	290	580	302
IEC-160	18.5 (22)	34	320	620	302
IEC-160	22 (26)	42	340	620	302
IEC-200	30 (35)	58	400	720	302

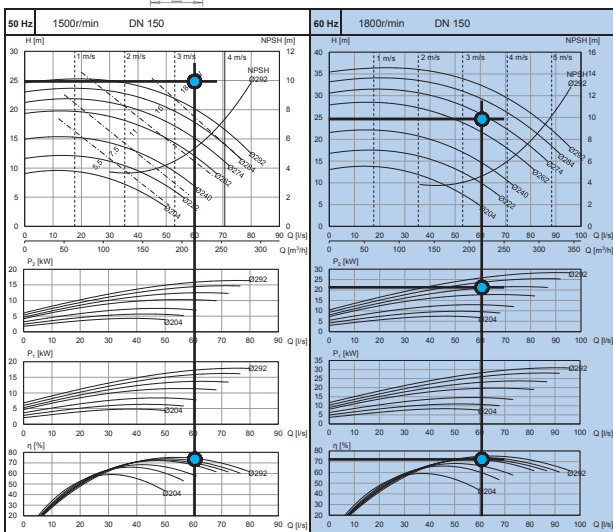

OVERSIZED PUMP

AL-1202/4 SD ALH-1202/4 SD ALP-1202/4 SD ALS-1202/4 SD

IEC-standard motor IM V1

Motor 400V	P_{2N} [kW]	I_{LN} [A]	[kg]	M [mm]	K [mm]
IEC-180	15	28	360	580	359
IEC-180	18.5	35	400	620	359
IEC-200	22	42	410	620	359
IEC-200	30	58	460	720	359
IEC-225	37	68	470	740	359
Motor 380-400V(460-480V)	P_{2N} [kW]	I_{LN} [A]	[kg]	M [mm]	K [mm]
IEC-180	18.5 (22)	34	400	620	359
IEC-180	22 (26)	42	410	620	359
IEC-200	30 (36)	58	460	720	359
IEC-225	37 (44)	68	470	740	359
IEC-225	45 (54)	81	480	750	359

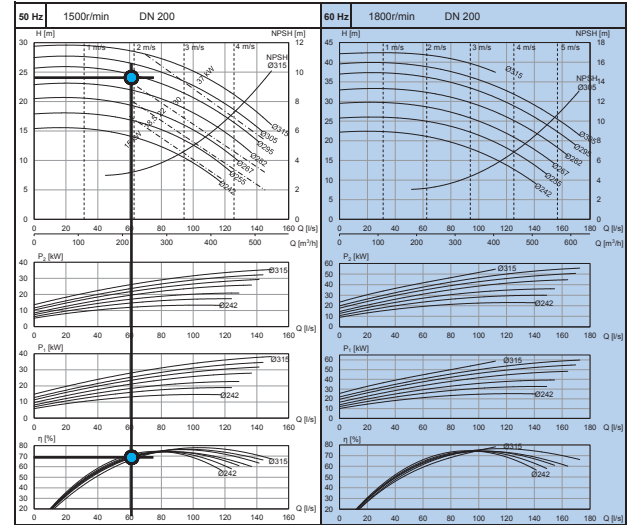

E.g. duty point: flow = 60 l/s, head = 25 m, pumped liquid being water +20°C.

1. Use the quick selection chart at the beginning of the catalogue or check the data sheets in the product catalogue to find a pump in the correct size range such that the required flow is in the best efficiency point. The AL-1154/4 SD pump is selected because its efficiency is the best in the required duty point $\eta = 75\%$.
2. The duty point is outside the operating range of the AL-1154/4 SD 50 Hz pump.
3. Usually when selecting the pump from the 50 Hz curve to the required higher duty point ($Q = 60$ l/s, 25 m), the next largest pump is selected. In the above example, we choose AL-1202/4 SD, $\varnothing 295$ mm, $P_2N = 30$ kW, $\eta = 67\%$. This is an oversized pump whose best flow range is within 100–120 l/s, where its efficiency is the highest $\eta = 80\%$.
4. Select the pump AL-1154/4 SD, 60 Hz curve, whereby the impeller is $\varnothing 274$ mm. The nominal motor shaft power P_2N is selected according to the shaft power curve P_2 . Shaft power $P_2 = 21$ kW and the next higher nominal power is $P_2N = 22$ kW. In this example, we choose AL-1154/4 SD, $\varnothing 274$ mm, $P_2N = 22$ kW, $\eta = 75\%$.

QH curves are available for 50 Hz and 60 Hz on the same data sheet in order to facilitate the customer's selection of the most energy efficient pump for frequency converter operation.

How does careful pump selection benefit the customer?

1. The pump saves energy, because it has been selected from the range of the best efficiency.
2. The total purchase cost is lower, because the pump, the electric motor and the frequency converter are one size smaller.
3. The pumps are designed to operate at the best efficiency where they run with low noise and vibration and have a long service life.
4. A smaller pump saves energy in partial flows, because its efficiency is better for the entire operating range.

NPSH and cavitation

$$NPSH_{re} < NPSH_{av}$$

$$NPSH_{re} < p + h - h_{suction} - p_h$$

$$NPSH_{re} < p_{suction} - p_h$$

$NPSH_{av}$ = difference between available inlet pressure (in suction flange) and vapour pressure of liquid being pumped

$NPSH_{re}$ = NPSH value required by the pump

p = Absolute air pressure

p_h = Absolute liquid vapour pressure at the operating temperature

h = Liquid geodetic suction head

$h_{suction}$ = Pressure losses in suction pipes

$p_{suction}$ = Absolute suction pressure

The $NPSH_{av}$ value of a system refers to the actual difference between inlet pressure (in the suction flange) and vapour pressure of the liquid being pumped. The $NPSH_{re}$ value required of the pump must be smaller than the $NPSH_{av}$ value in order to prevent cavitation from occurring. A safety margin of 0.5 m must be added to the measurement value.

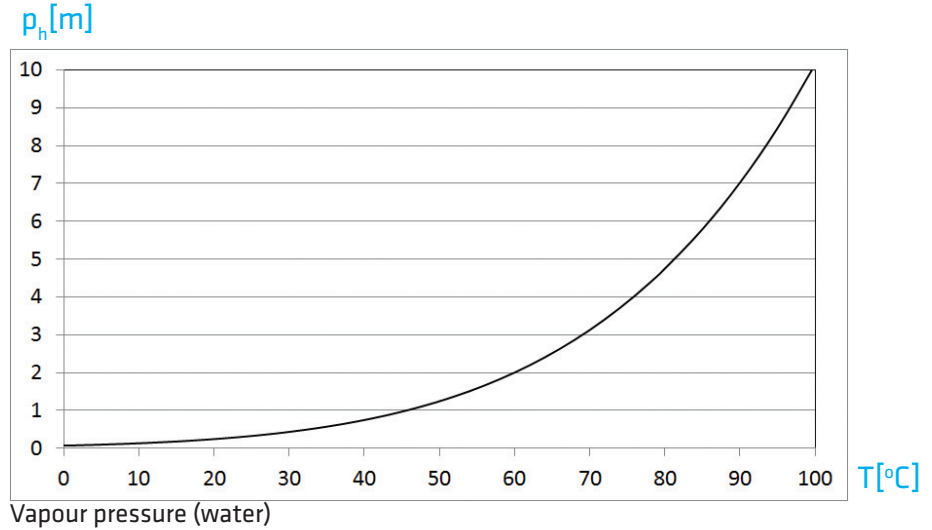

At normal air pressure levels (10 m water column, 1,013 mbar = 760 mm Hg), clean water boils at 100°C. It can be seen from the curve that water boils at 60°C when the absolute pressure is 2 m wc (i.e. 8 m wc below atmospheric pressure). The boiling point of water at less than 40°C can be achieved at a very low pressure. Vice versa, at the top of Mount Everest, where air pressure is about 0.6 bar (6 m), water boils at +85°C.

Example:

Open tank (p = air pressure = 10 m) where the water temperature is + 90°C (p_h = 7 m), suction pipe losses 1 m and liquid suction head flange +2 m. The pump duty point 20 l/s, 7.8 m.

Is the selected pump suitable for the use in question? An example of calculation:

Pump type:
AL_-1129/4 SD Ø288 15 kW

$$NPSH_{re} < p + h - h_{suction} - p_h$$

$$NPSH_{re} < 10 \text{ m} + 2 \text{ m} - 1 \text{ m} - 7 \text{ m}$$

$$NPSH_{re} < 4 \text{ m}$$

When observing the safety margin 0,5 m, the $NPSH_{re}$ value of the pump must be smaller than 3,5 m in order to prevent the pump from cavitating. $NPSH_{re}$ of pump AL_-1129/4 SD Ø288 $NPSH_{re} = 2,7 \text{ m}$ -> whereby it will not cavitate.

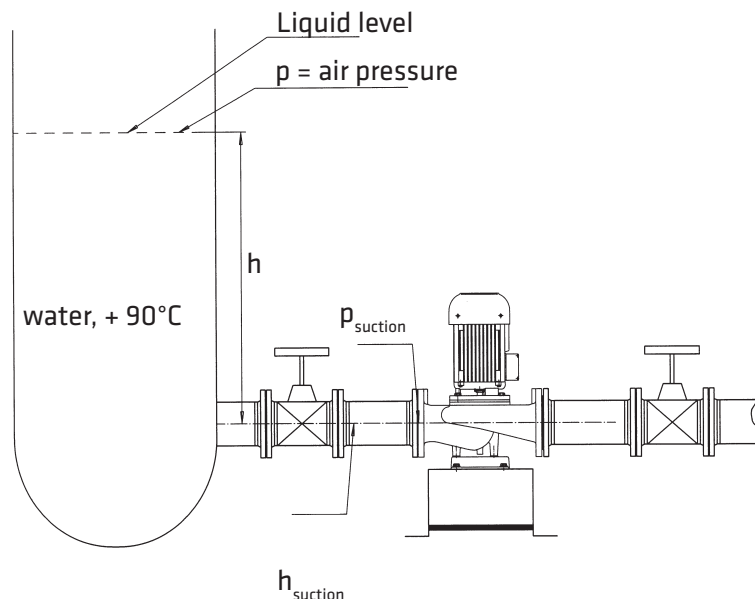

L-100S/4 SD

LH-100S/4 SD

LP-100S/4 SD

P101293

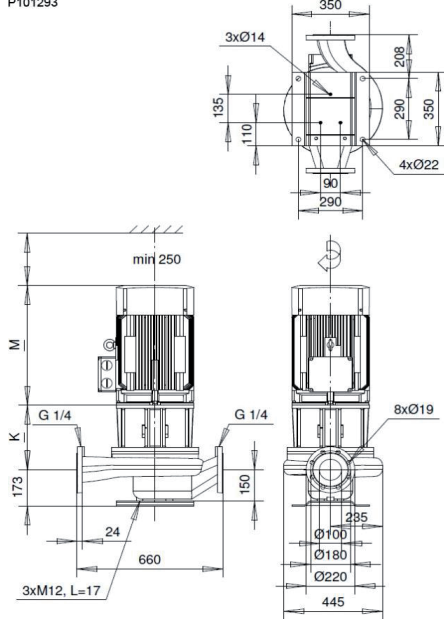

IEC-standard motor IM V1

Motor 400V	P_{2N} [kW]	I_N [A] ~	[kg] ~	M [mm] ~	K [mm] ~	
	IEC-132	5,5	11	200	490	260
IEC-132	7,5	15	210	490	260	
IEC-160	11	21	270	580	308	
IEC-160	15	28	280	580	308	
Motor 380-400V(460-480V)	P_{2N} [kW]	I_N [A] ~	[kg] ~	M [mm] ~	K [mm] ~	
	IEC-132	5,5 (6,6)	11	200	490	260
	IEC-132	7,5 (9)	15	210	490	260
	IEC-160	11 (13)	21	270	580	308
	IEC-160	15 (18)	28	280	580	308
	IEC-180	18,5 (22)	34	310	620	308
IEC-180	22 (26)	42	330	620	308	

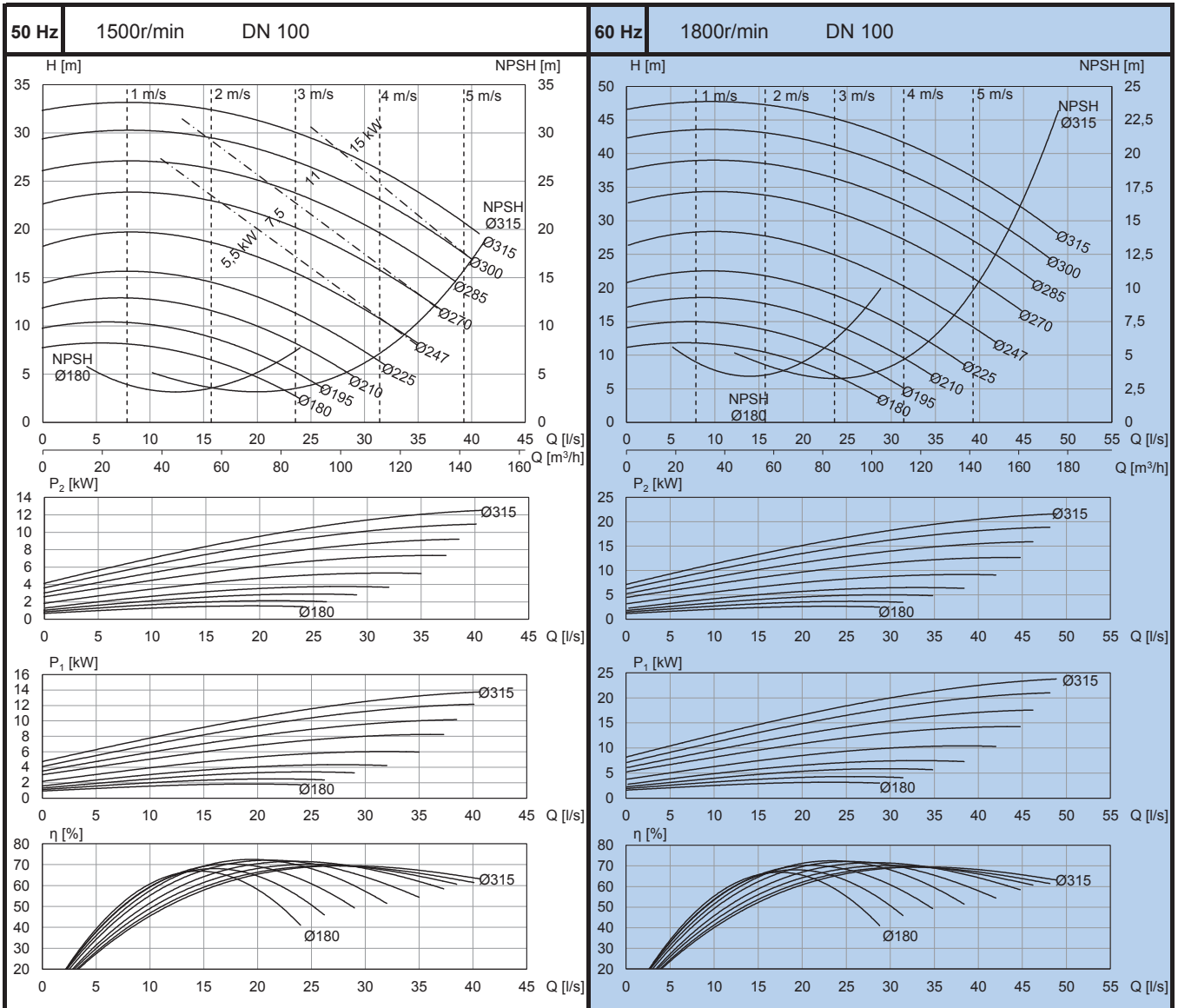

L-100S/2 SD

LH-100S/2 SD

LP-100S/2 SD

P101274

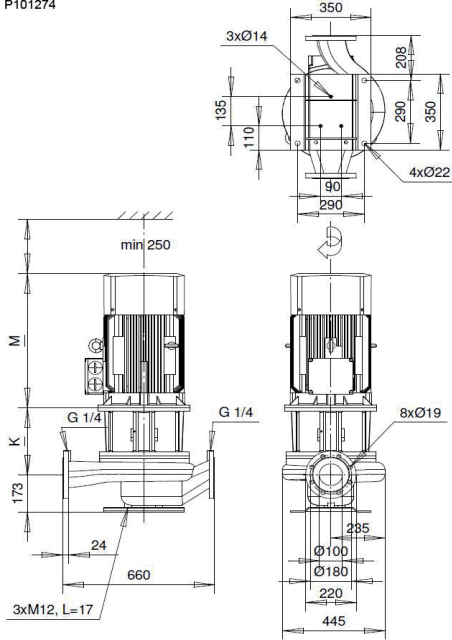

IEC-standard motor IM V1

50Hz	Motor 400V	P_{2N} [kW]	I_N [A] ~	[kg] ~	M [mm] ~	K [mm] ~
	IEC-160	15	27	260	580	308
IEC-160	18,5	33	270	620	308	
IEC-180	22	39	330	620	308	
IEC-200	30	53	370	720	308	
IEC-200	37	65	390	720	308	
IEC-225	45	78	440	740	308	

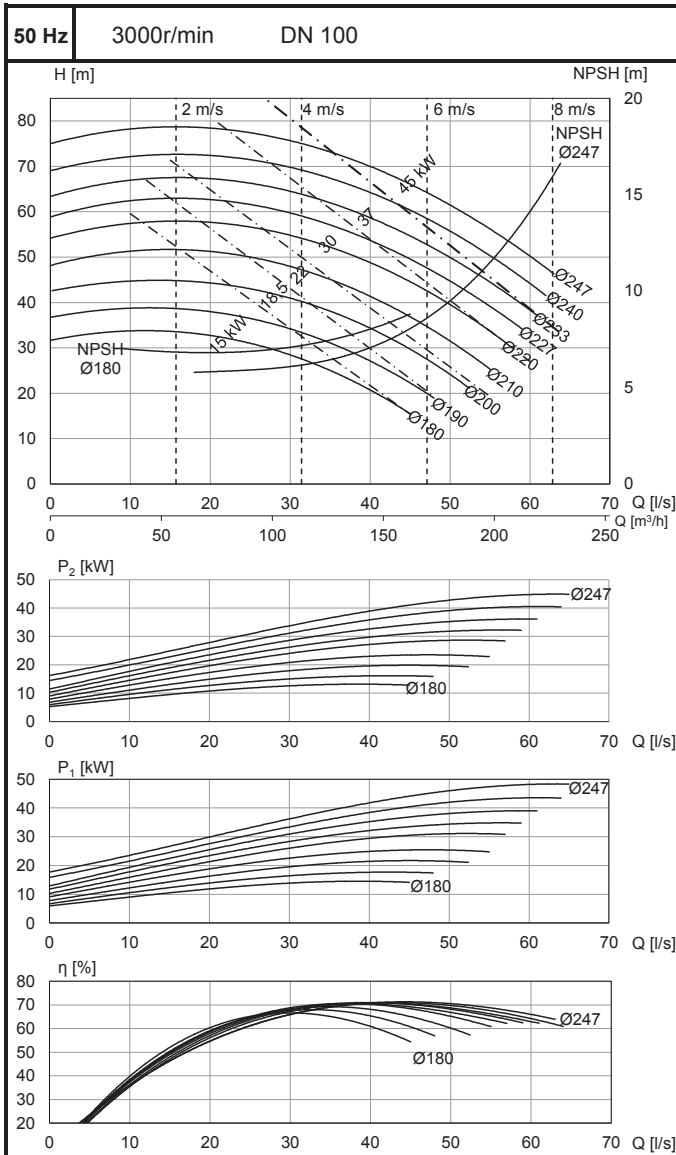

AL-1129/4 SD

ALH-1129/4 SD

ALS-1129/4 SD

P101294

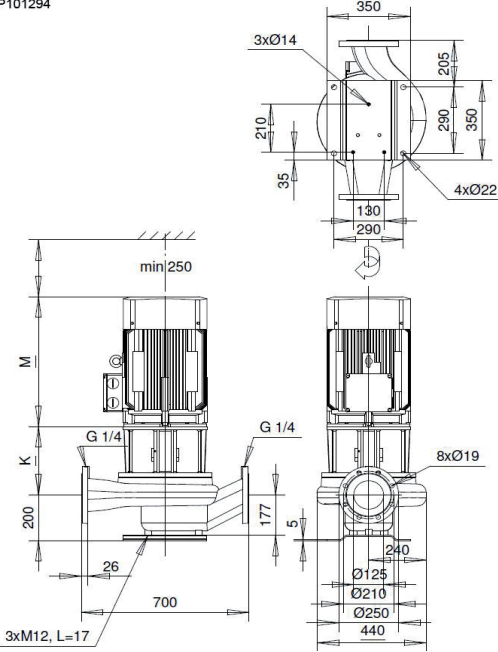

IEC-standard motor IM V1

Motor 400V	P_{2N} [kW]	I_N [A] ~	[kg] ~	M [mm] ~	K [mm] ~	
	IEC-132	5,5	11	200	490	252
IEC-132	7,5	15	210	490	252	
IEC-160	11	21	270	580	300	
IEC-160	15	28	280	580	300	
Motor 380-400V(460-480V)	P_{2N} [kW]	I_N [A] ~	[kg] ~	M [mm] ~	K [mm] ~	
	IEC-132	5,5 (6,6)	11	200	490	252
	IEC-132	7,5 (9)	15	210	490	252
	IEC-160	11 (13)	21	270	580	300
	IEC-160	15 (18)	28	280	580	300
	IEC-180	18,5 (22)	34	320	620	300
IEC-180	22 (26)	42	330	620	300	

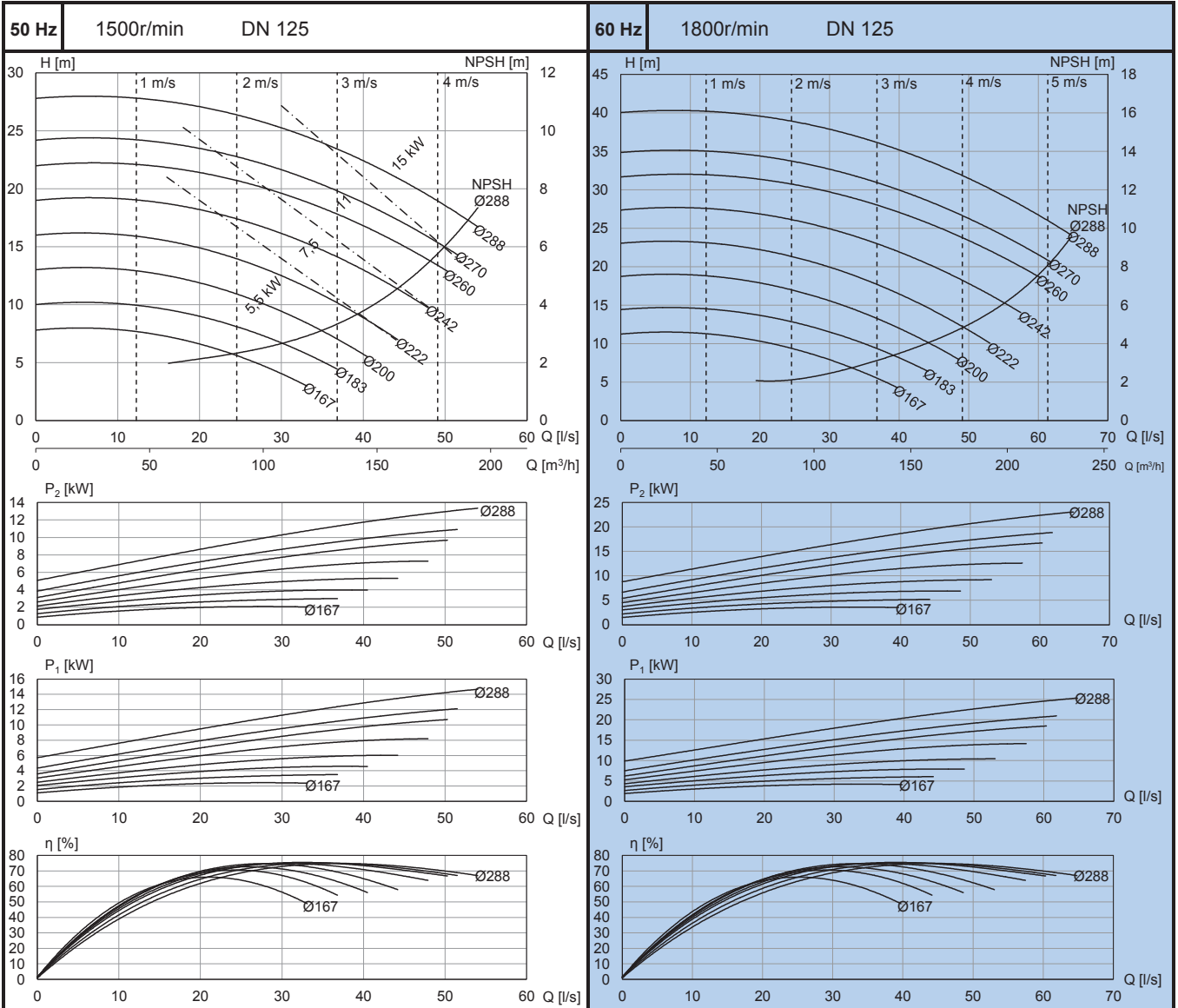

AL-1129/2 SD

ALH-1129/2 SD

ALS-1129/2 SD

P101284

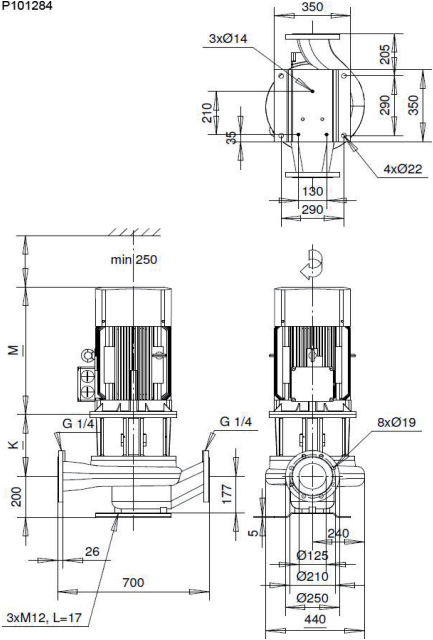

IEC-standard motor IM V1

50Hz	Motor 400V	P_{2N} [kW]	I_N [A] ~	[kg] ~	M [mm] ~	K [mm] ~
	IEC-200	30	53	370	720	300
	IEC-200	37	65	400	720	300

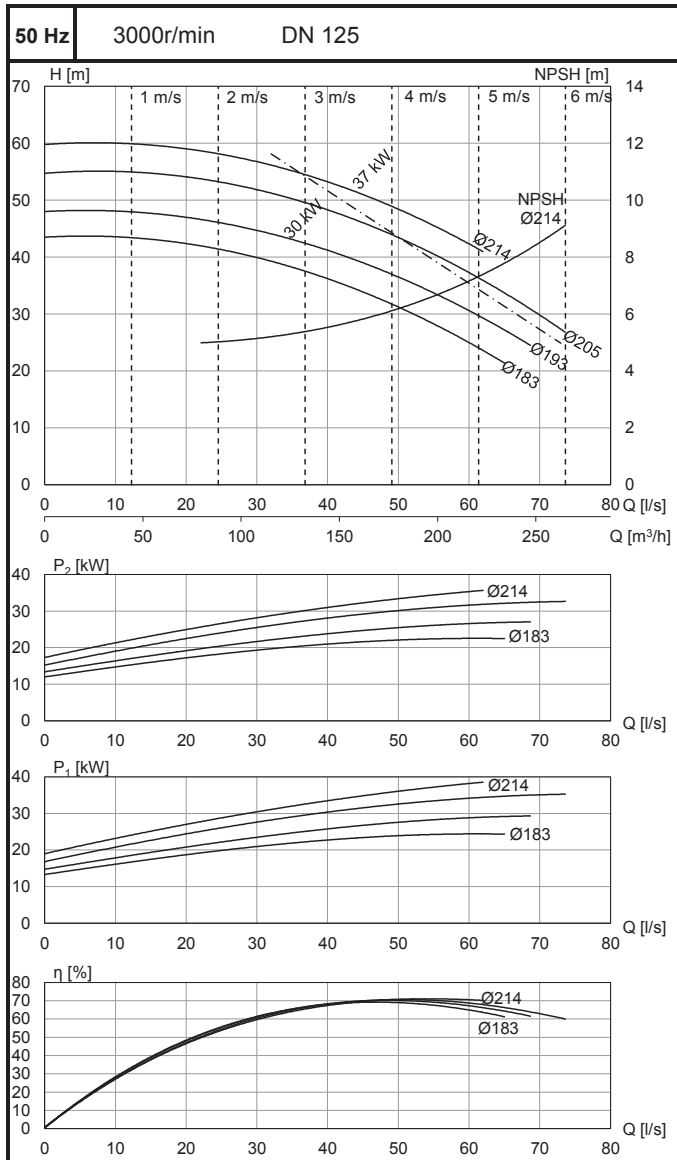

ALP-1128/4 SD

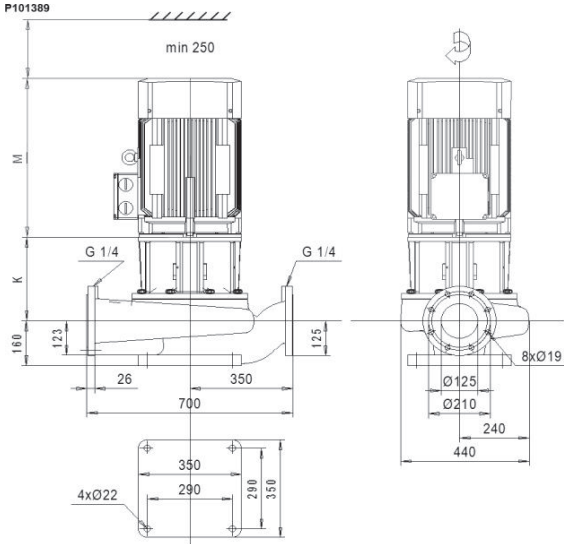

IEC-standard motor IM V1

Motor 400V	P_{2N} [kW]	I_N [A] ~	[kg] ~	M [mm] ~	K [mm] ~
	IEC-132	5,5	11	200	490
IEC-132	7,5	15	210	490	252
IEC-160	11	21	270	580	300
IEC-160	15	28	280	580	300
Motor 380-400V(460-480V)	P_{2N} [kW]	I_N [A] ~	[kg] ~	M [mm] ~	K [mm] ~
IEC-132	5,5 (6,6)	11	200	490	252
IEC-132	7,5 (9)	15	210	490	252
IEC-160	11 (13)	21	270	580	300
IEC-160	15 (18)	28	280	580	300
IEC-180	18,5 (22)	34	320	620	300
IEC-180	22 (26)	42	330	620	300

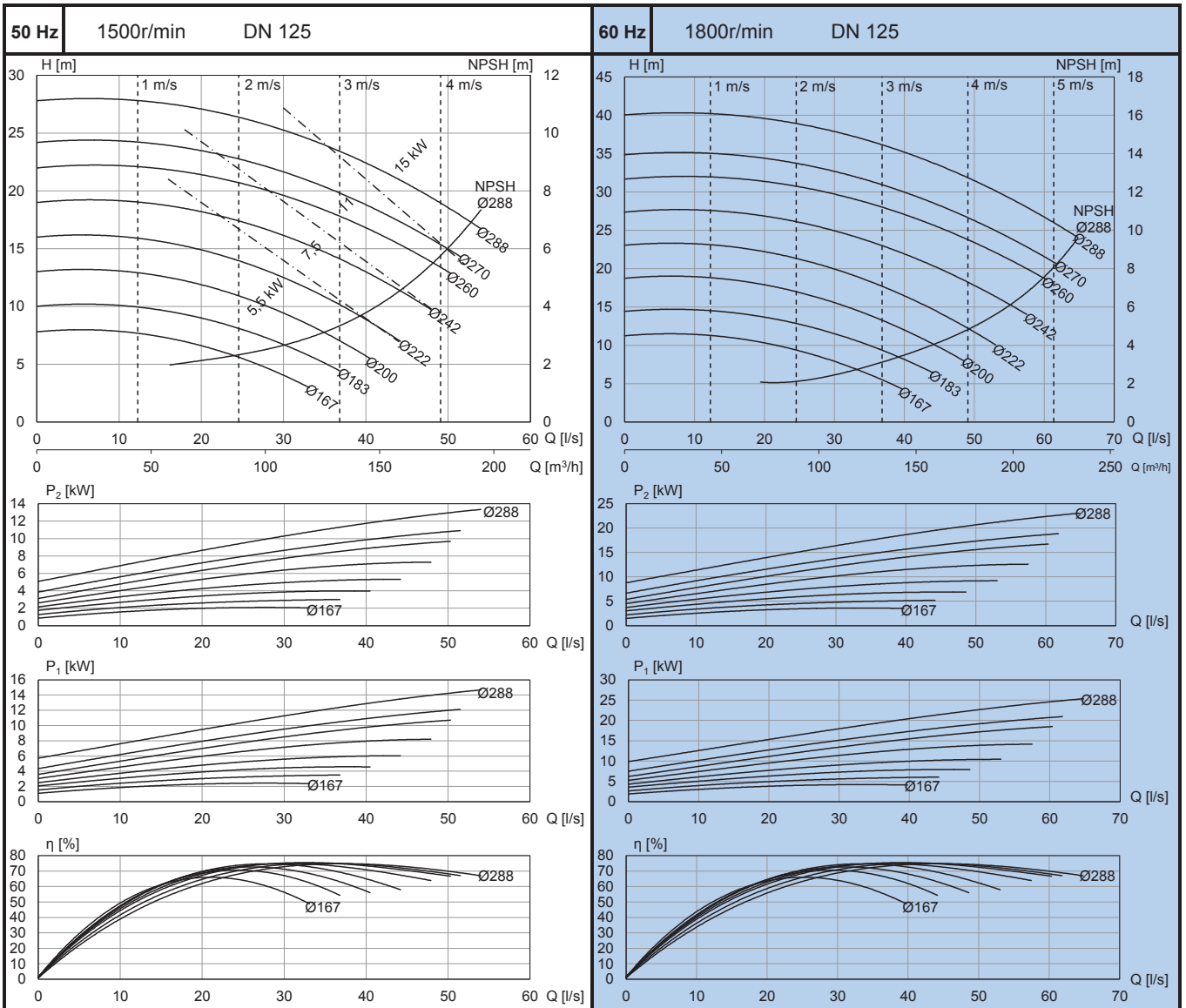

ALP-1128/2 SD

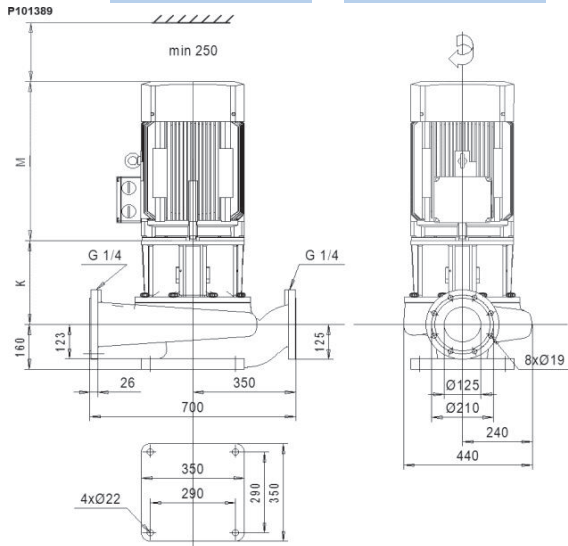

IEC-standard motor IM V1

50 Hz	Motor 400V	P_{2N} [kW]	I_N [A] ~	[kg] ~	M [mm] ~	K [mm] ~
	IEC-200	30	53	370	720	300
IEC-200	37	65	400	720	300	

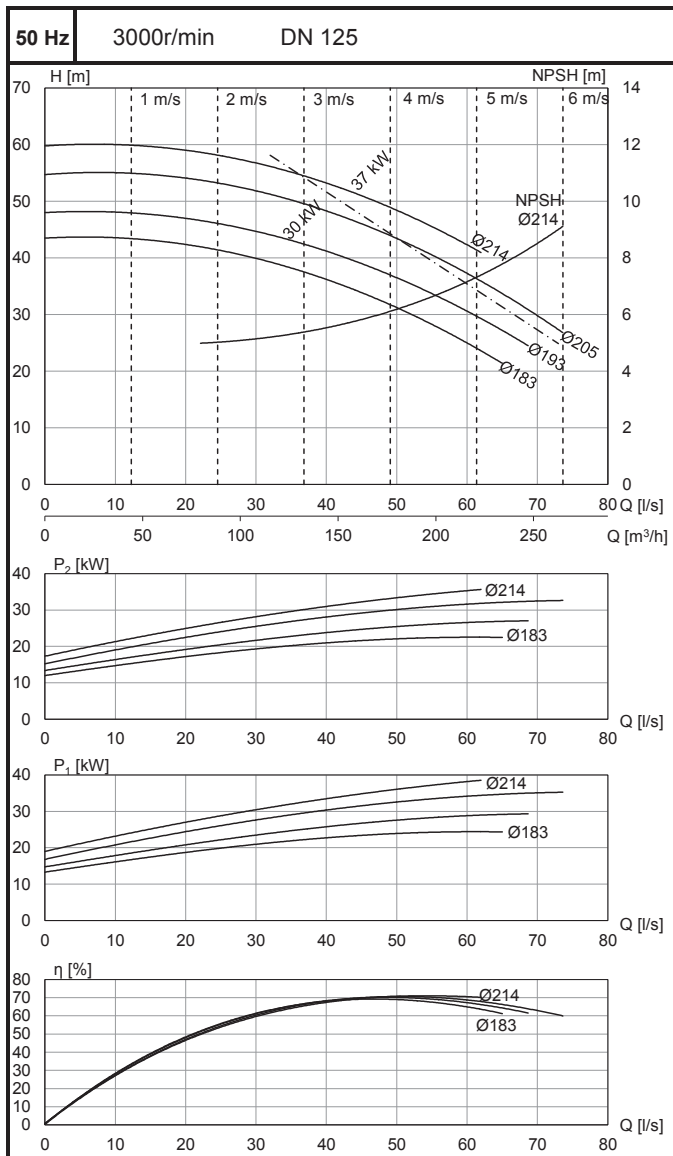

L-125S/4 SD

LH-125S/4 SD

LS-125S/4 SD

P101292

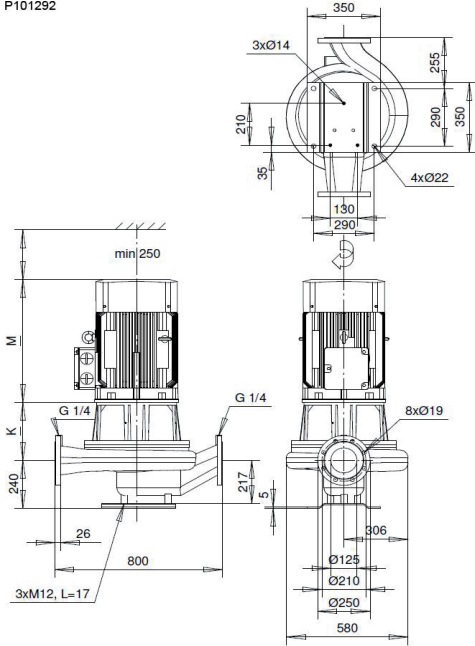

IEC-standard motor IM V1

Motor 400V	P_{2N} [kW]	I_N [A] ~	[kg] ~	M [mm] ~	K [mm] ~
IEC-180	18,5	35	380	620	292
IEC-180	22	42	390	620	292
IEC-200	30	58	440	720	292
IEC-225	37	68	460	740	292
IEC-225	45	81	480	740	292
Motor 380-400V(460-480V)	P_{2N} [kW]	I_N [A] ~	[kg] ~	M [mm] ~	K [mm] ~
IEC-180	18,5 (22)	34	380	620	292
IEC-180	22 (26)	42	390	620	292
IEC-200	30 (36)	58	440	720	292
IEC-225	37 (44)	68	460	740	292
IEC-225	45 (54)	81	480	740	292
IEC-250	55 (66)	99	530	750	292

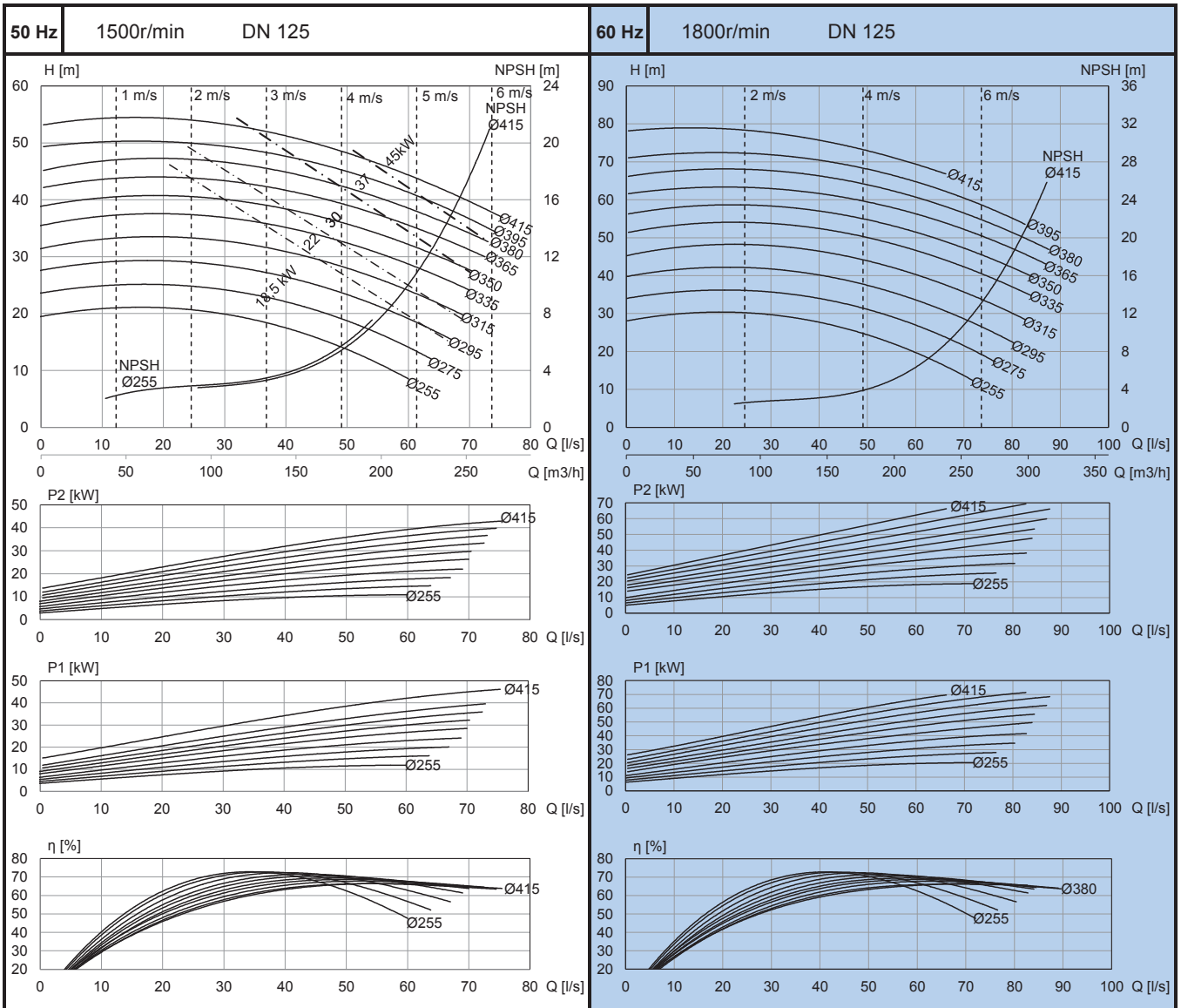

ALP-1153/6 SD

IEC-standard motor IM V1

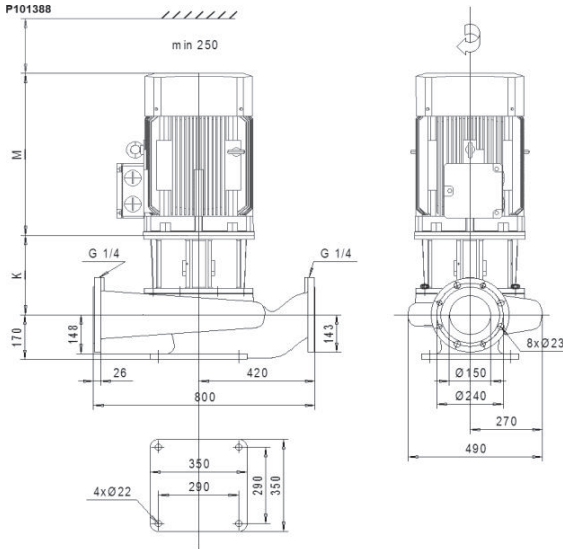

50Hz	Motor 400V	P_{2N} [kW]	I_N [A] ~	[kg] ~	M [mm] ~	K [mm] ~
	IEC-132	4	9	210	490	254
IEC-132	5,5	12	220	490	254	
60Hz	Motor 380-400V(460-480V)	P_{2N} [kW]	I_N [A] ~	[kg] ~	M [mm] ~	K [mm] ~
	IEC-132	4 (4,8)	9	210	490	254
	IEC-132	5,5 (6,6)	12	220	490	254
	IEC-160	7,5 (9)	16	270	580	302
IEC-160	11 (13)	23	280	580	302	

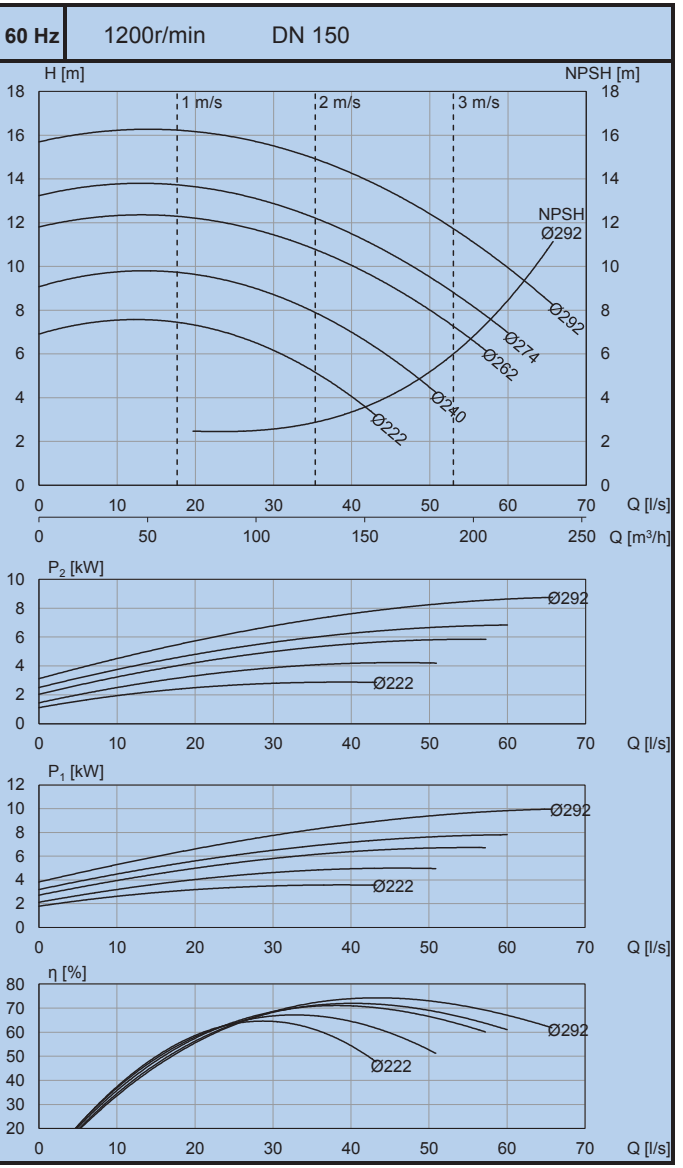
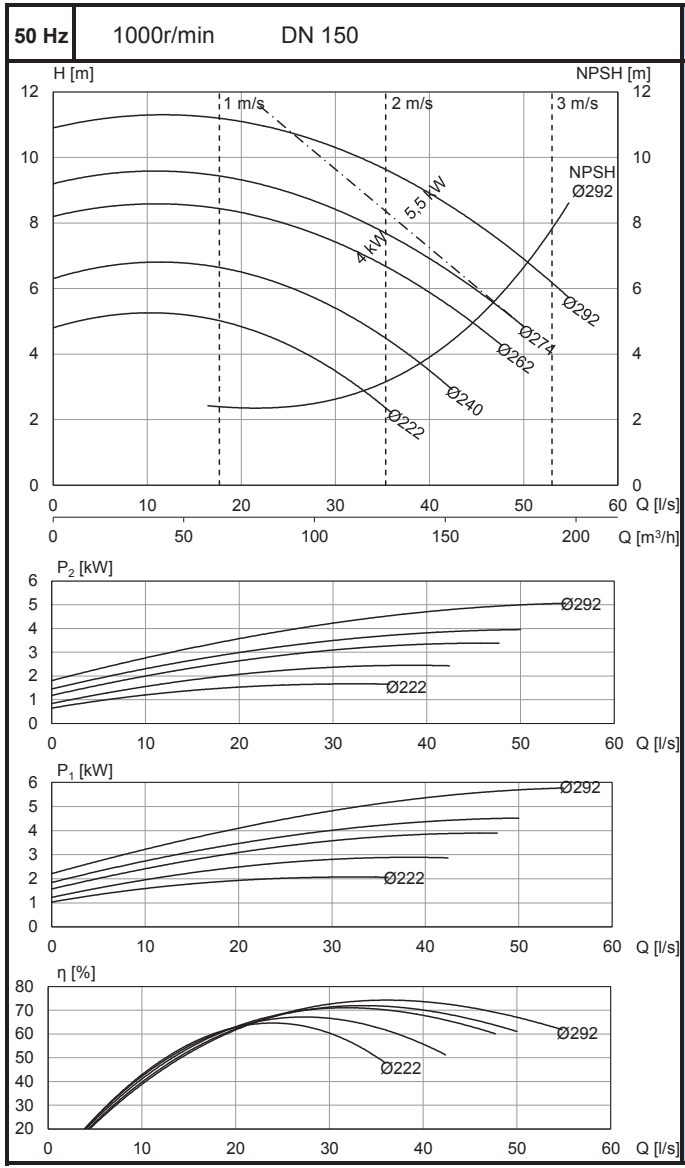

ALP-1153/4 SD

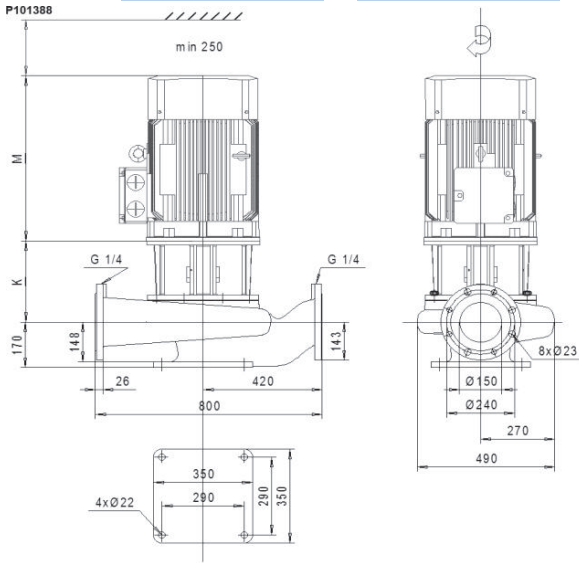

IEC-standard motor IM V1

	Motor 400V	P_{2N} [kW]	I_N [A] ~	[kg] ~	M [mm] ~	K [mm] ~
	50Hz	IEC-132	5,5	11	210	490
IEC-132		7,5	15	220	490	254
IEC-160		11	21	280	580	302
IEC-160		15	28	290	580	302
IEC-180		18,5	35	320	620	302
	Motor 380-400V(460-480V)	P_{2N} [kW]	I_N [A] ~	[kg] ~	M [mm] ~	K [mm] ~
	60Hz	IEC-132	5,5 (6,6)	11	210	490
IEC-132		7,5 (9)	15	220	490	254
IEC-160		11 (13)	21	280	580	302
IEC-160		15 (18)	28	290	580	302
IEC-180		18,5 (22)	34	320	620	302
IEC-180		22 (26)	42	340	620	302
IEC-200		30 (30)	58	400	720	302

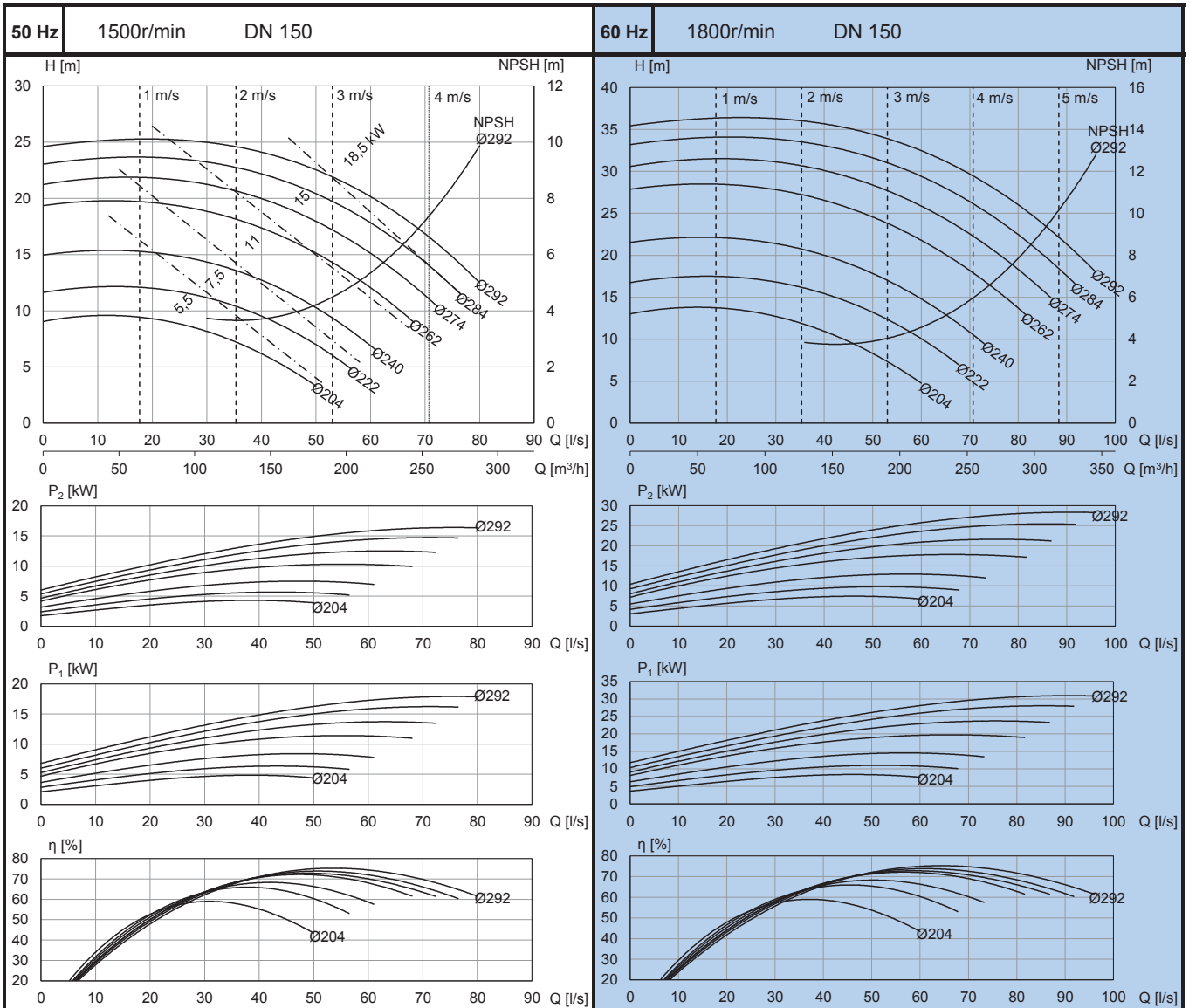

AL-1154/6 SD

ALH-1154/6 SD

ALS-1154/6 SD

P101286

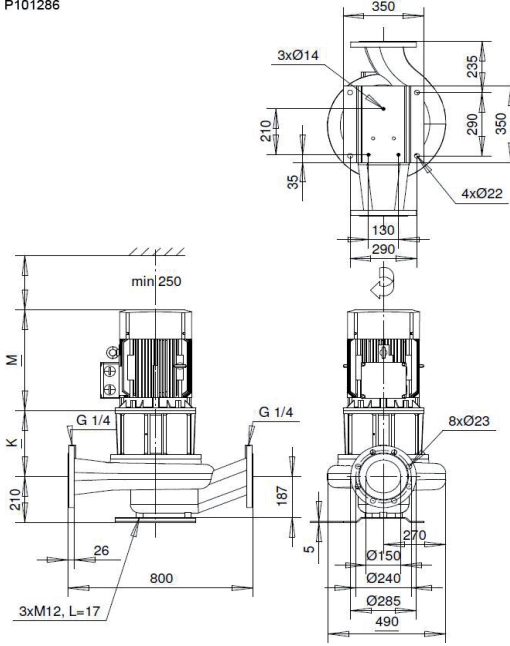

IEC-standard motor IM V1

50Hz	Motor 400V	P_{2N} [kW]	I_N [A] ~	[kg] ~	M [mm] ~	K [mm] ~
	IEC-132	4	9	210	490	254
IEC-132	5,5	12	220	490	254	
60Hz	Motor 380-400V(460-480V)	P_{2N} [kW]	I_N [A] ~	[kg] ~	M [mm] ~	K [mm] ~
	IEC-132	4 (4,8)	9	210	490	254
	IEC-132	5,5 (6,6)	12	220	490	254
	IEC-160	7,5 (9)	16	270	580	302
IEC-160	11 (13)	23	280	580	302	

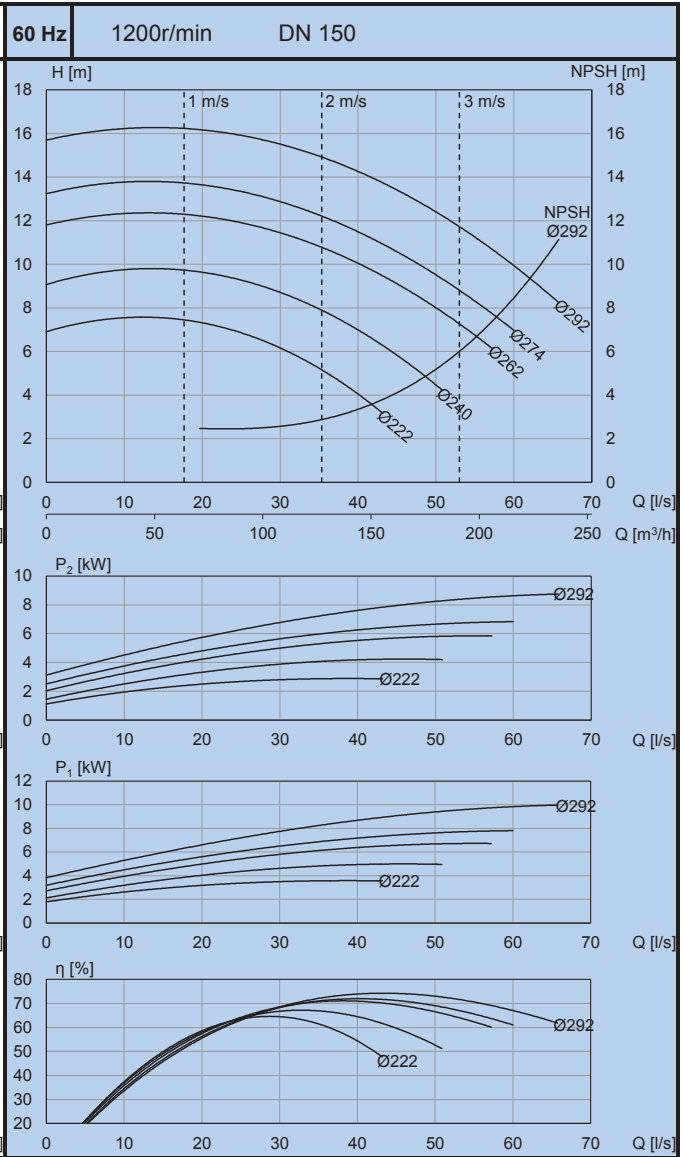
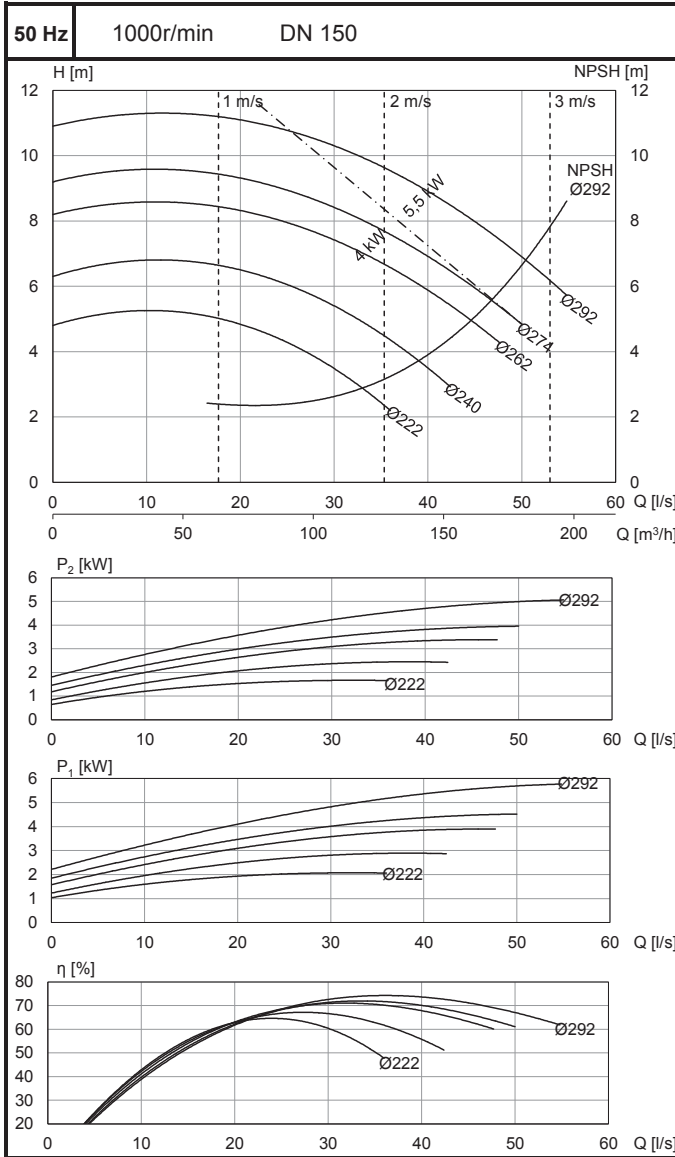

AL-1154/4 SD

ALH-1154/4 SD

ALS-1154/4 SD

P101289

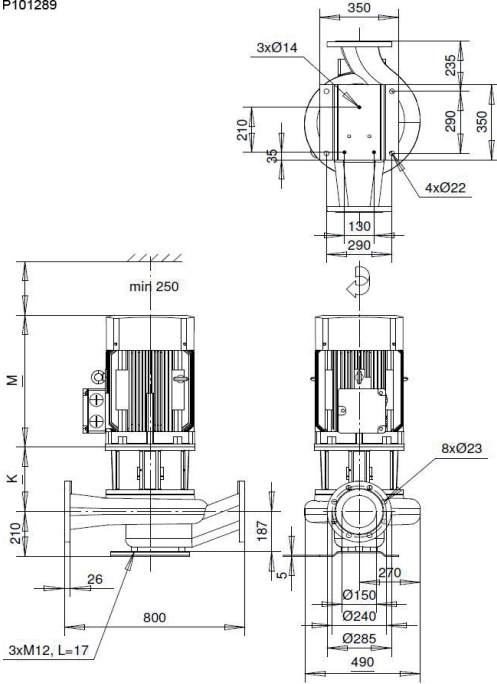

IEC-standard motor IM V1

Motor 400V	P_{2N} [kW]	I_N [A] ~	[kg] ~	M [mm] ~	K [mm] ~
	IEC-132	5,5	11	210	490
IEC-132	7,5	15	220	490	254
IEC-160	11	21	280	580	302
IEC-160	15	28	290	580	302
IEC-180	18,5	35	320	620	302
Motor 380-400V(460-480V)	P_{2N} [kW]	I_N [A] ~	[kg] ~	M [mm] ~	K [mm] ~
IEC-132	5,5 (6,6)	11	210	490	254
IEC-132	7,5 (9)	15	220	490	254
IEC-160	11 (13)	21	280	580	302
IEC-160	15 (18)	28	290	580	302
IEC-180	18,5 (22)	34	320	620	302
IEC-180	22 (26)	42	340	620	302
IEC-200	30 (30)	58	400	720	302

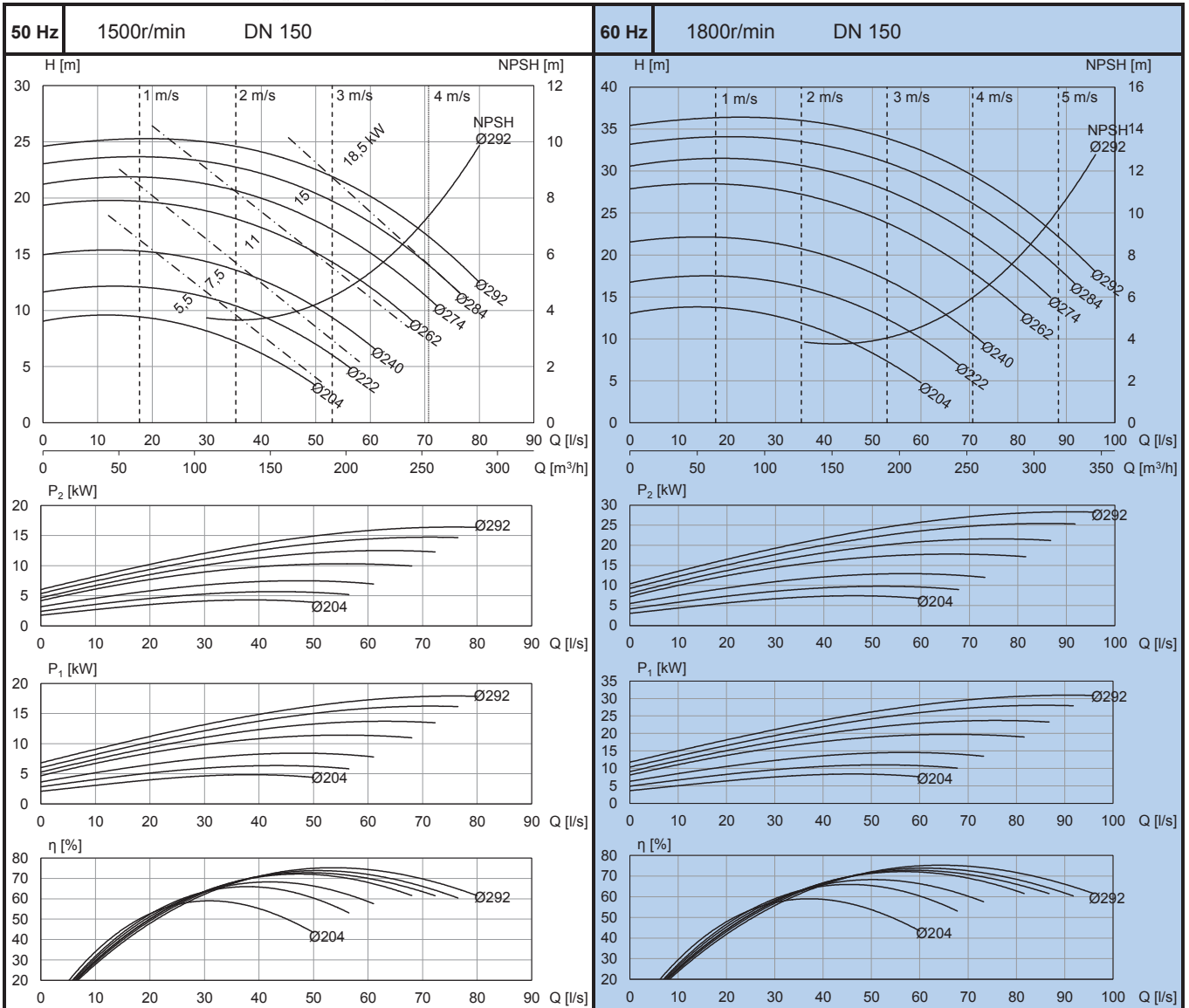

AL-1202/6 SD

ALH-1202/6 SD

ALP-1202/6 SD

ALS-1202/6 SD

P101299

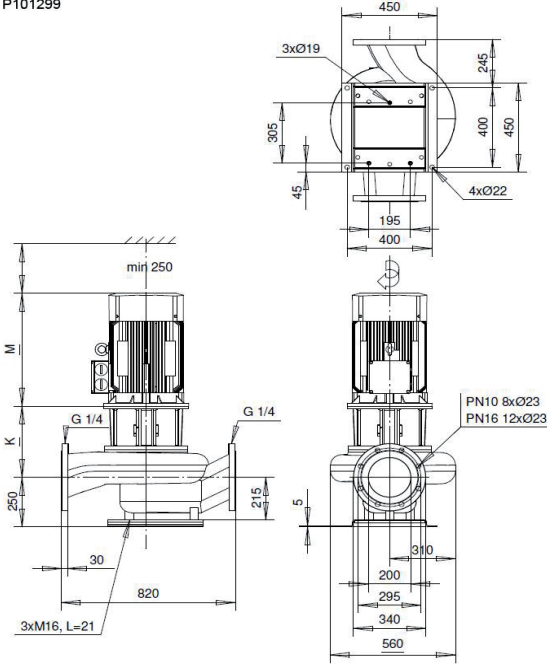

IEC-standard motor IM V1

ZH05	Motor 400V	P_{2N} [kW]	I_N [A] ~	[kg] ~	M [mm] ~	K [mm] ~
	IEC-132	4	9	300	490	311
IEC-132	5,5	12	310	490	311	
IEC-160	7,5	16	340	580	359	
IEC-160	11	23	350	580	359	
ZH09	Motor 380-400V(460-480V)	P_{2N} [kW]	I_N [A] ~	[kg] ~	M [mm] ~	K [mm] ~
	IEC-132	4 (4,8)	9	300	490	311
	IEC-132	5,5 (6,6)	12	310	490	311
	IEC-160	7,5 (9)	16	340	580	359
	IEC-160	11 (13)	23	350	580	359
	IEC-180	15 (18,5)	31	410	620	359
IEC-200	18,5 (22)	37	470	720	359	

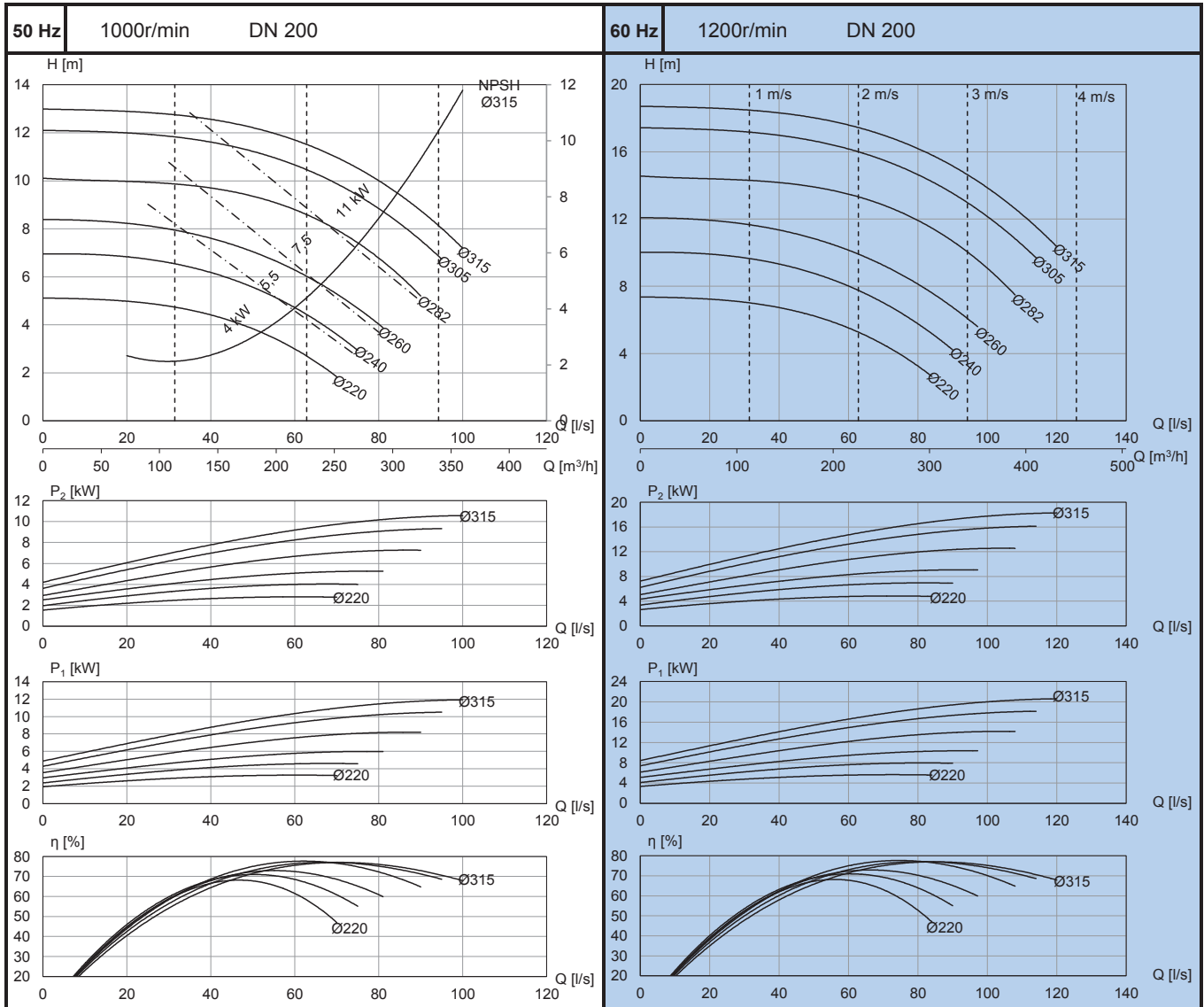

AL-1202/4 SD

ALH-1202/4 SD

ALP-1202/4 SD

ALS-1202/4 SD

P101301

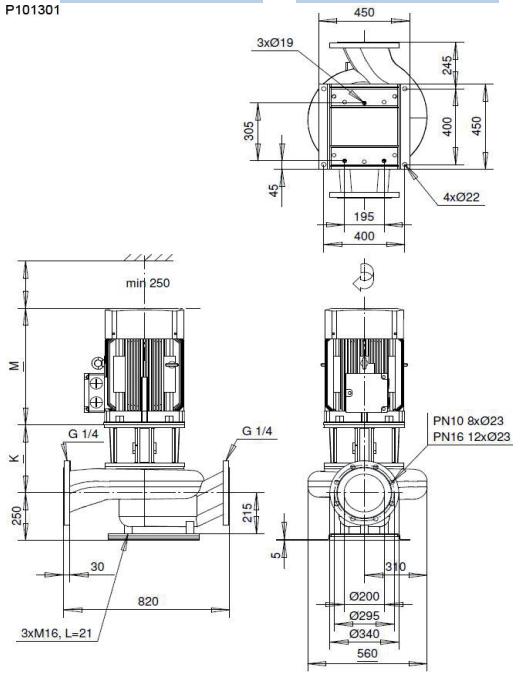

IEC-standard motor IM V1

Motor 400V	P_{2N} [kW]	I_N [A] ~	[kg] ~	M [mm] ~	K [mm] ~
	IEC-160	15	28	360	580
IEC-180	18,5	35	400	620	359
IEC-180	22	42	410	620	359
IEC-200	30	58	460	720	359
IEC-225	37	68	470	740	359
Motor 380-400V(460-480V)	P_{2N} [kW]	I_N [A] ~	[kg] ~	M [mm] ~	K [mm] ~
IEC-180	18,5 (22)	34	400	620	359
IEC-180	22 (26)	42	410	620	359
IEC-200	30 (36)	56	460	720	359
IEC-225	37 (44)	68	470	740	359
IEC-225	45 (54)	81	480	750	359

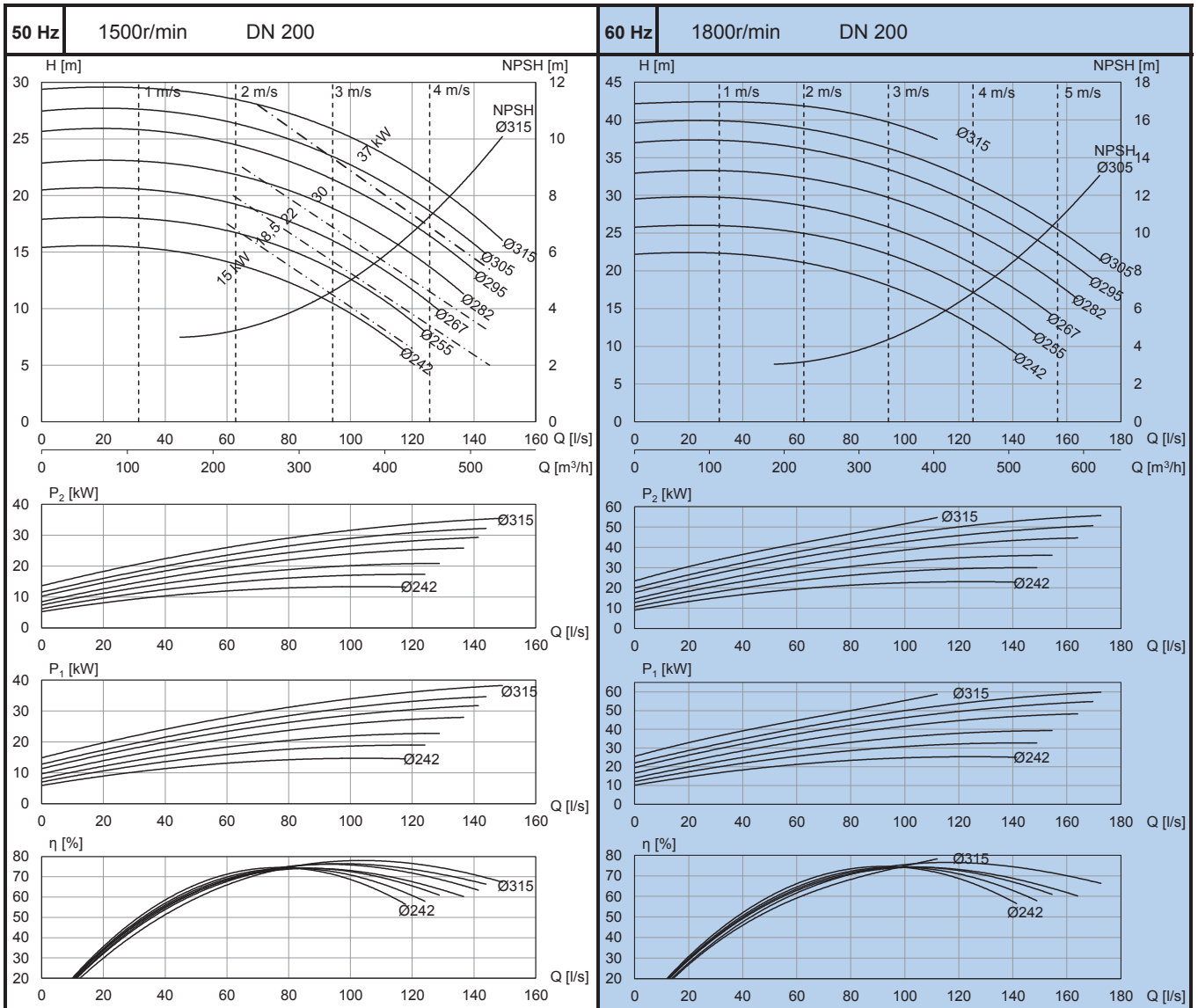

AL-1250/6 SD

ALH-1250/6 SD

ALS-1250/6 SD

P101310

IEC-standard motor IM V1

ZH05	Motor 400V	P_{2N} [kW]	I_N [A] ~	[kg] ~	M [mm] ~	K [mm] ~
	IEC-180	15	31	510	620	370
	IEC-200	18,5	37	580	720	370
	IEC-225	30	57	640	740	370
ZH09	Motor 380-400V(460-480V)	P_{2N} [kW]	I_N [A] ~	[kg] ~	M [mm] ~	K [mm] ~
	IEC-200	18,5 (22)	37	580	720	370
	IEC-200	22 (26)	42	590	720	370
	IEC-200	30 (36)	57	640	740	370

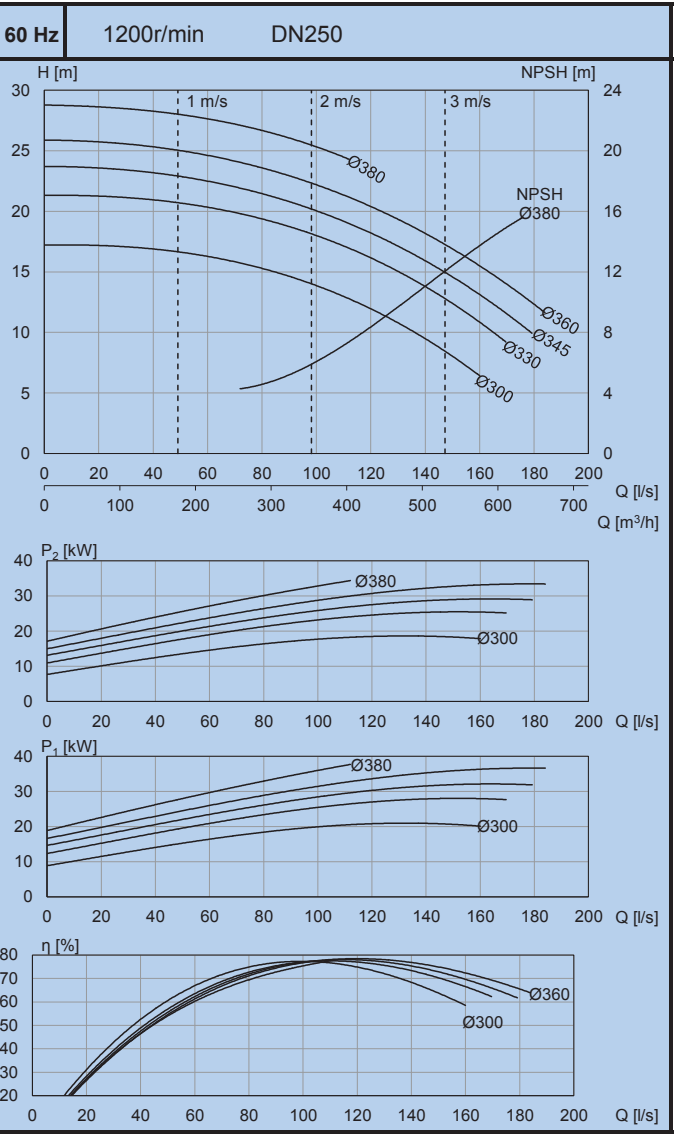
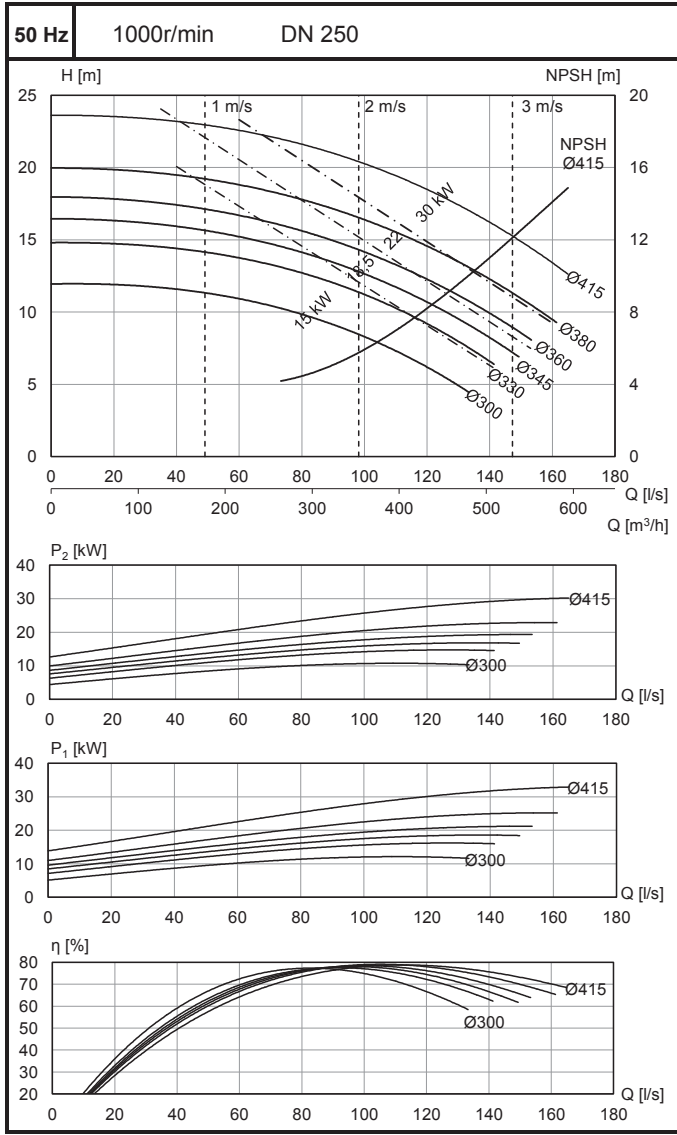
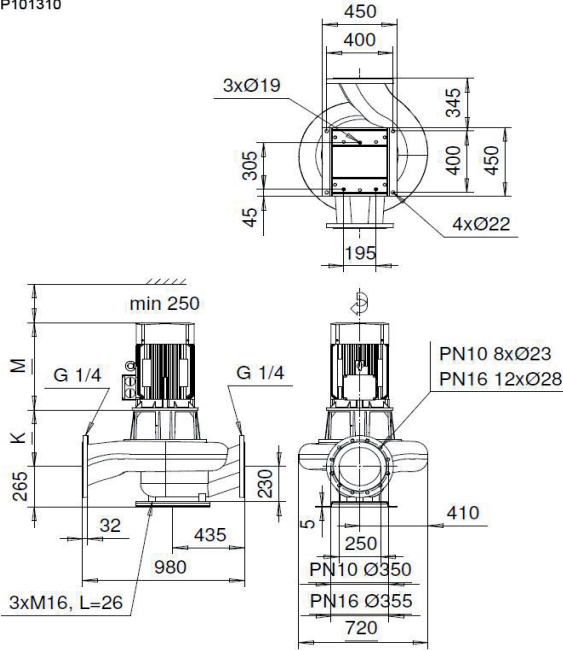

AL-1250/4 SD

ALH-1250/4 SD

ALS-1250/4 SD

P101352

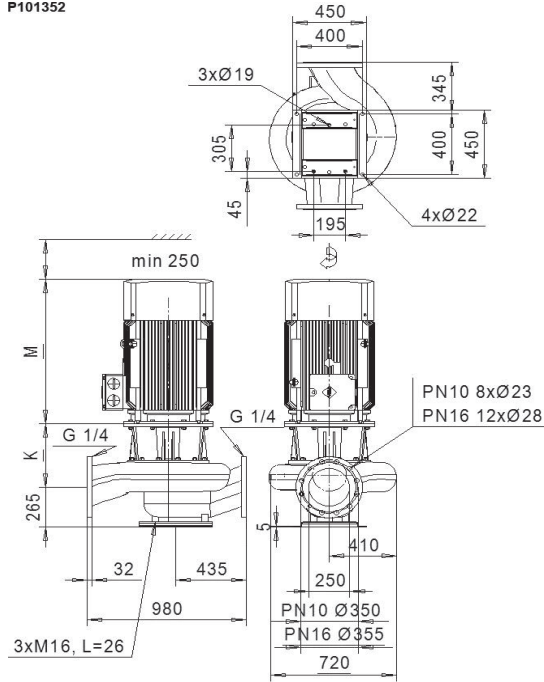

IEC-standard motor IM V1

	Motor 400V	P_{2N} [kW]	I_N [A] ~	[kg] ~	M [mm] ~	K [mm] ~
	ZH05	IEC-225	37	68	620	740
IEC-225		45	81	640	740	408
IEC-250		55	99	690	750	428
IEC-280		75	134	900	950	428
IEC-280		90	159	940	950	428
	Motor 380-400V(460-480V)	P_{2N} [kW]	I_N [A] ~	[kg] ~	M [mm] ~	K [mm] ~
	ZH06	IEC-225	45 (54)	81	640	740
IEC-250		55 (66)	99	690	750	428
IEC-280		75 (90)	134	900	950	428
IEC-280		90 (105)	159	940	950	428

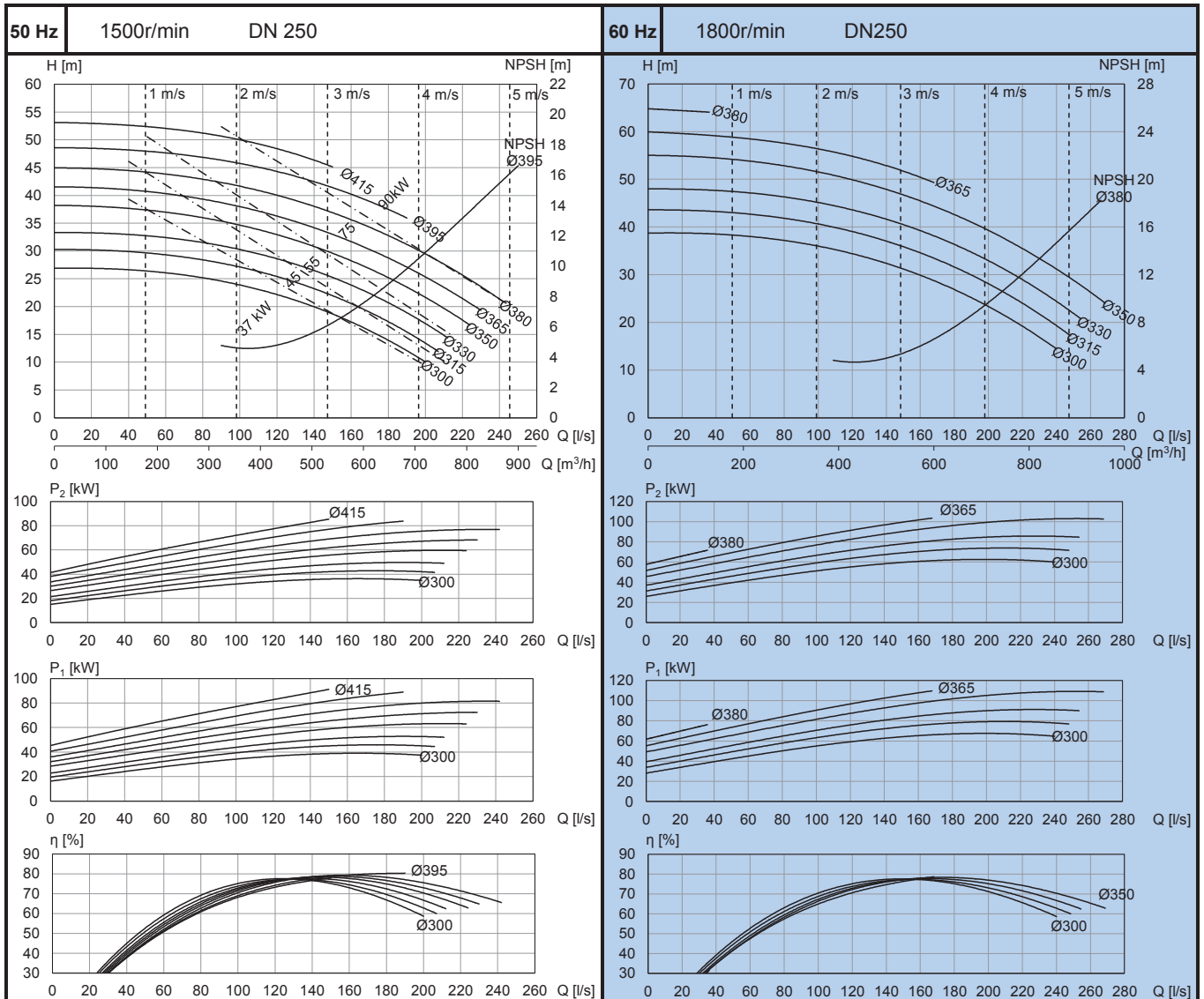



KOLMEKS
EFFICIENT RELIABILITY

KolmeKs Oy

Taimistotie 2
FI-14200 Turenki
FINLAND

Phone. +358 20 7521 31
Fax +358 20 7521 200

kolmeKs@kolmeKs.fi
www.kolmeKs.fi/en