

PRODUCT INFORMATION  
CANNED MOTOR PUMP TYPE CNF

# REFRIGERATION ENGINEERING

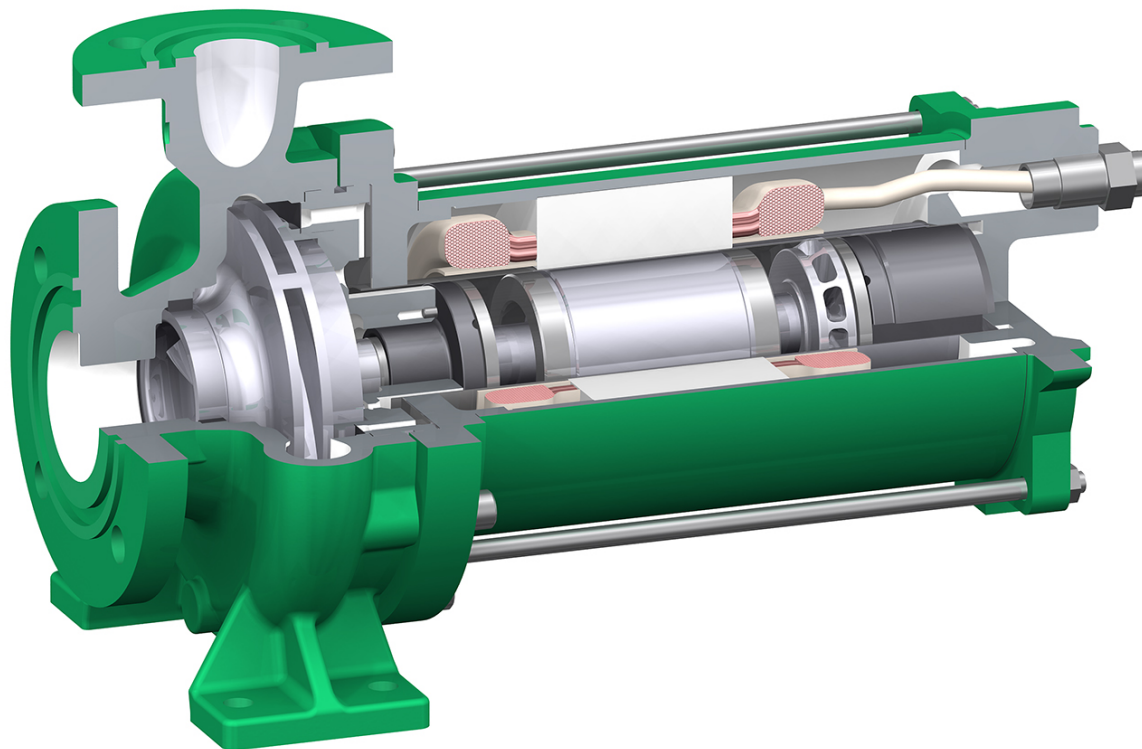

**ZART®**

*simply best balance*

## Table of Contents

General information .....	3	Documentation and tests .....	14
Function .....	5	Installation .....	15
Operating principle .....	6	Protection and monitoring .....	16
Bearings .....	6	Flow regulation .....	17
Characteristic maps .....	7	Flow regulator .....	17
2900 rpm 50 Hz .....	7	Design software .....	20
3500 rpm 60 Hz .....	8	Design software / services .....	20
Versions .....	9	Benefits of the design software .....	21
Versions CNF .....	9	Contact .....	22
Materials / pressure stages / flanges .....	10		
Noise expectancy values .....	10		
List of parts .....	11		
Collective measurements .....	12		
Dimension drawings .....	12		
Versions CNF .....	13		

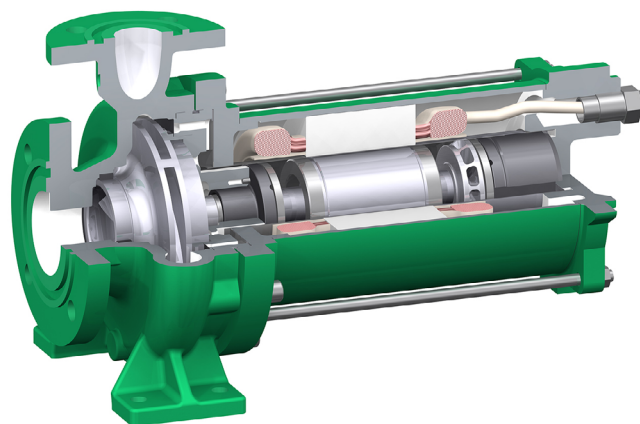

## Table of Contents

General information
Function
Operating principle
Characteristic maps
Versions
List of parts
Collective measurements
Documentation and tests
Installation
Protection and monitoring
Flow regulation
Design software
Contact

## Information

---

### Applications

- Food industry: Cooling and deep-freezing with natural and synthetic refrigerants
- Sports and leisure facilities, such as bobsled tracks, ice rinks or ice hockey stadiums
- Electronics and power converters: modules in mobile (railway) and stationary (offshore wind turbines) applications
- Cooling modules in the chemical industry (optionally in explosion-proof design)
- Freeze-drying and oil-cooling systems for transformers
- CO<sub>2</sub> cooling for mainframes and server centres
- Absorption refrigeration applications with lithium bromide and NH<sub>3</sub>

### Pumped media

Liquids and liquefied gases, such as NH<sub>3</sub> (R717), CO<sub>2</sub> (R744), R22, R134a, hydrocarbons, R404a, R11, R12, Baysilone (M3, M5), methanol, silicone oil KT3, Syltherm XLT, water glycol mixtures. In principle, the refrigerant pumps are suitable for conveying all types of refrigerant. However, this must be checked for each case.

### Type / design

Horizontal, seal-less spiral housing pumps in process design with completely closed canned motor with radial impeller, single-stage, single-flow. The connection measurements of the housing comply with EN 22 858 / ISO 2858.

### Canned motor type

The CNF model is the version for liquefied gases, boiling media and condensate. With an integrated auxiliary impeller and internal fluid return, it is suitable for conveying liquids close to steam pressure.

### Drive

The rotor lining, one of our core competences, is manufactured using the compact extrusion method and as a nickel-base alloy, it is an essential component of the highly efficient canned motor. The canned motor filled with liquid accelerates to the operating speed in seconds. It is wear-free and maintenance-free during continuous operation due to the hydrodynamic sleeve bearings. The canned motor is low-noise and low-vibration and offers double security against leakage.

Table of Contents

**General information**

Function

Operating principle

Characteristic maps

Versions

List of parts

Collective measurements

Documentation and tests

Installation

Protection and monitoring

Flow regulation

Design software

Contact



**Information**

---

**Operating data**

**Temperature**

Application conditions	-50 °C to +30 °C
------------------------	------------------

**Canned motors**

Output	up to 15.7 kW
--------	---------------

Speed	2800 rpm or 3500 rpm (frequency control possible – from 1500 rpm to 3500 rpm)
-------	-------------------------------------------------------------------------------

Voltage	230, 400, 480, 500, 575, 690 Volt
---------	-----------------------------------

Frequency	50 or 60 Hz
-----------	-------------

Type of protection	IP 55
--------------------	-------

**Pump and hydraulics designations**

**CNF 40 – 160 AGX 3.0**

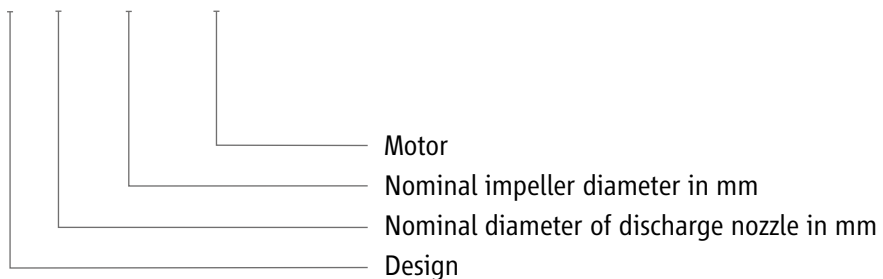

Table of Contents

**General information**

Function

Operating principle

Characteristic maps

Versions

List of parts

Collective measurements

Documentation and tests

Installation

Protection and monitoring

Flow regulation

Design software

Contact



## Function CNF

To cool the motor and lubricate the bearings, a portion of the flow is branched off at the periphery of the impeller and returned to the pressure side after flowing through the motor. An auxiliary impeller serves to compensate for hydraulic losses that arise this way. Due to the partial flow return to the pressure side, point 3 in the pressure-temperature diagram corresponding to the largest heating has sufficient distance from the boiling curve. Under otherwise identical conditions, it is, therefore, possible to use the CNF model for pumping liquid gases with an extremely steep vapour pressure curve.

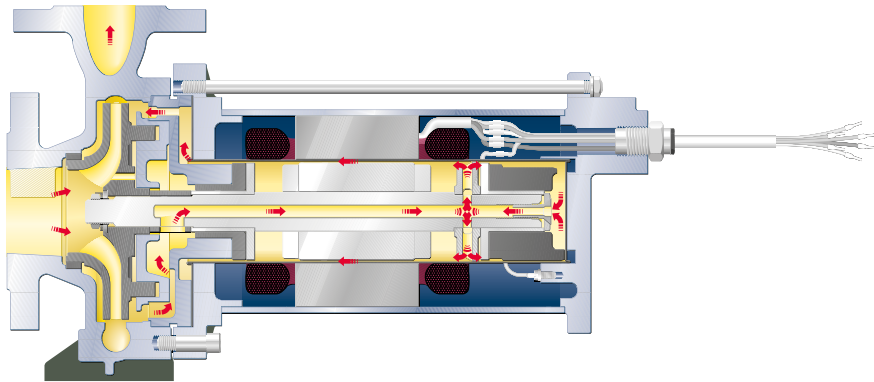

Partial flow return to the pressure side

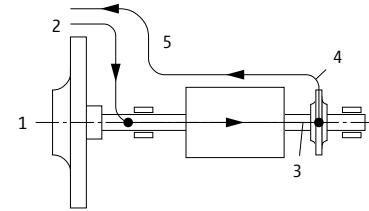

Pressure-temperature diagram

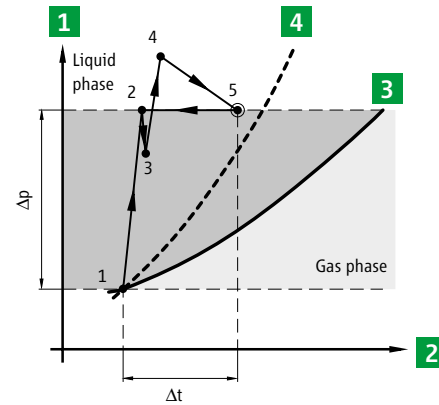

- 1 Pressure
- 2 Temperature
- 3 flat vapour pressure curve (e. g. water)
- 4 steep vapour pressure curve (e. g. liquefied gases)

Table of Contents

General information

**Function**

Operating principle

Characteristic maps

Versions

List of parts

Collective measurements

Documentation and tests

Installation

Protection and monitoring

Flow regulation

Design software

Contact



## Bearings

---

The hermetically sealed design requires the arrangement of bearings in the pumped liquid. Therefore, only hydrodynamic plain bearings are used in HERMETIC pumps. With correct operational mode, these bearings have the advantage that there is no contact between the bearing sliding surfaces. As a result, they are wear-free and maintenance-free in continuous operation. A service life of 20 years is common for hermetically sealed pumps.

In refrigeration engineering, carbon graphite is used as the bearing bush material that can withstand particularly high radial and axial loads. In addition, the material has a high resistance to elevated and low temperatures and high fatigue strength.

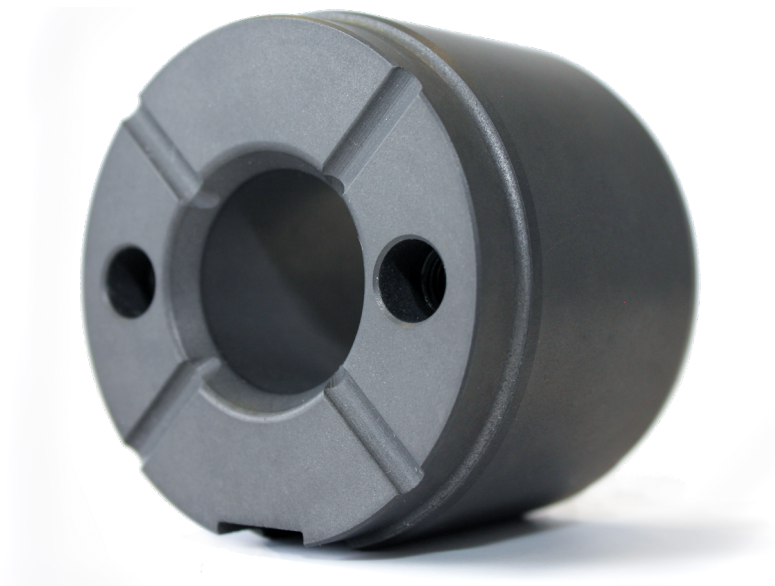

Table of Contents

General information

Function

**Operating principle**

Characteristic maps

Versions

List of parts

Collective measurements

Documentation and tests

Installation

Protection and monitoring

Flow regulation

Design software

Contact



2900 rpm 50 Hz

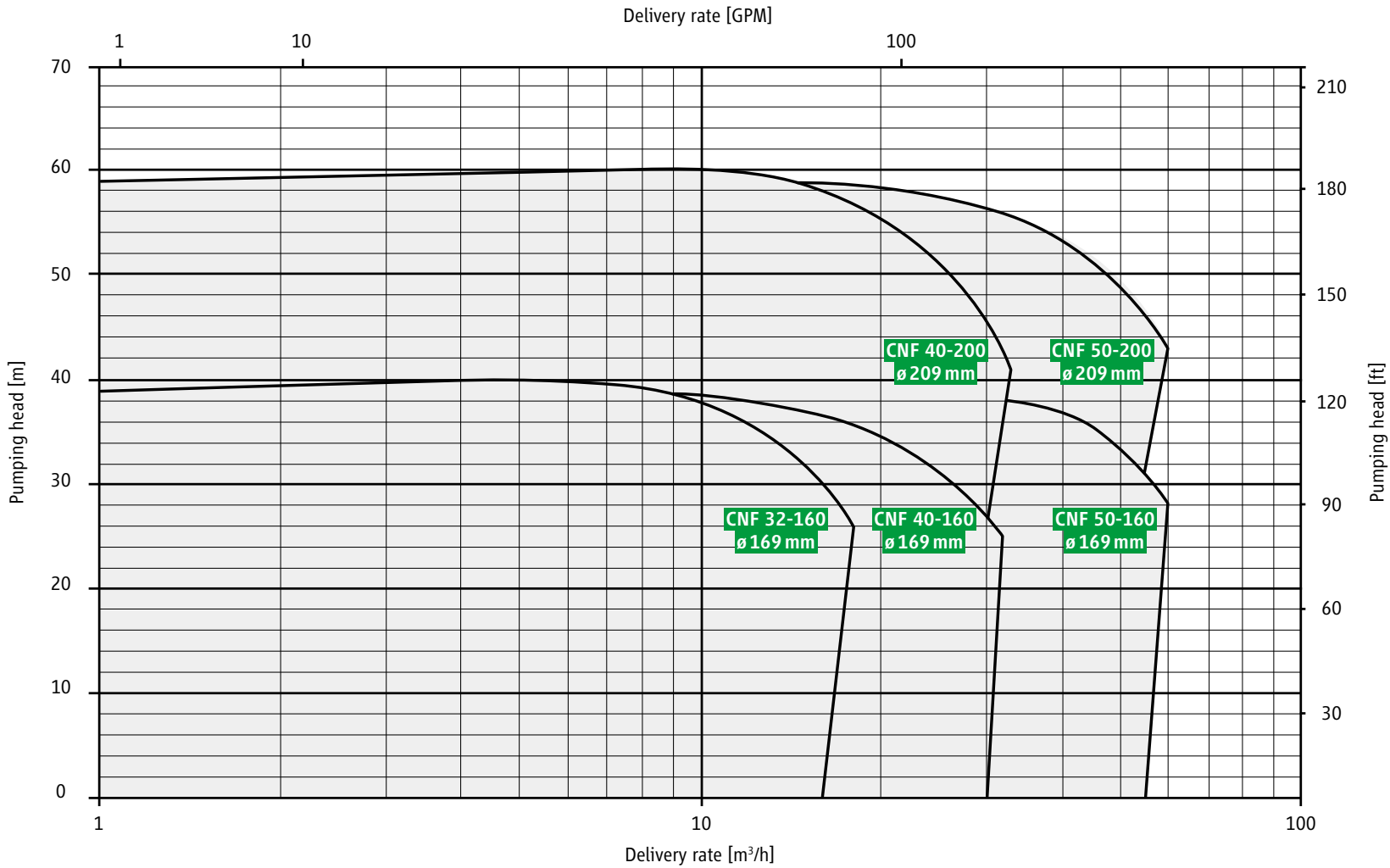

- Table of Contents
- General information
- Function
- Operating principle
- Characteristic maps**
- Versions
- List of parts
- Collective measurements
- Documentation and tests
- Installation
- Protection and monitoring
- Flow regulation
- Design software
- Contact



3500 rpm 60 Hz

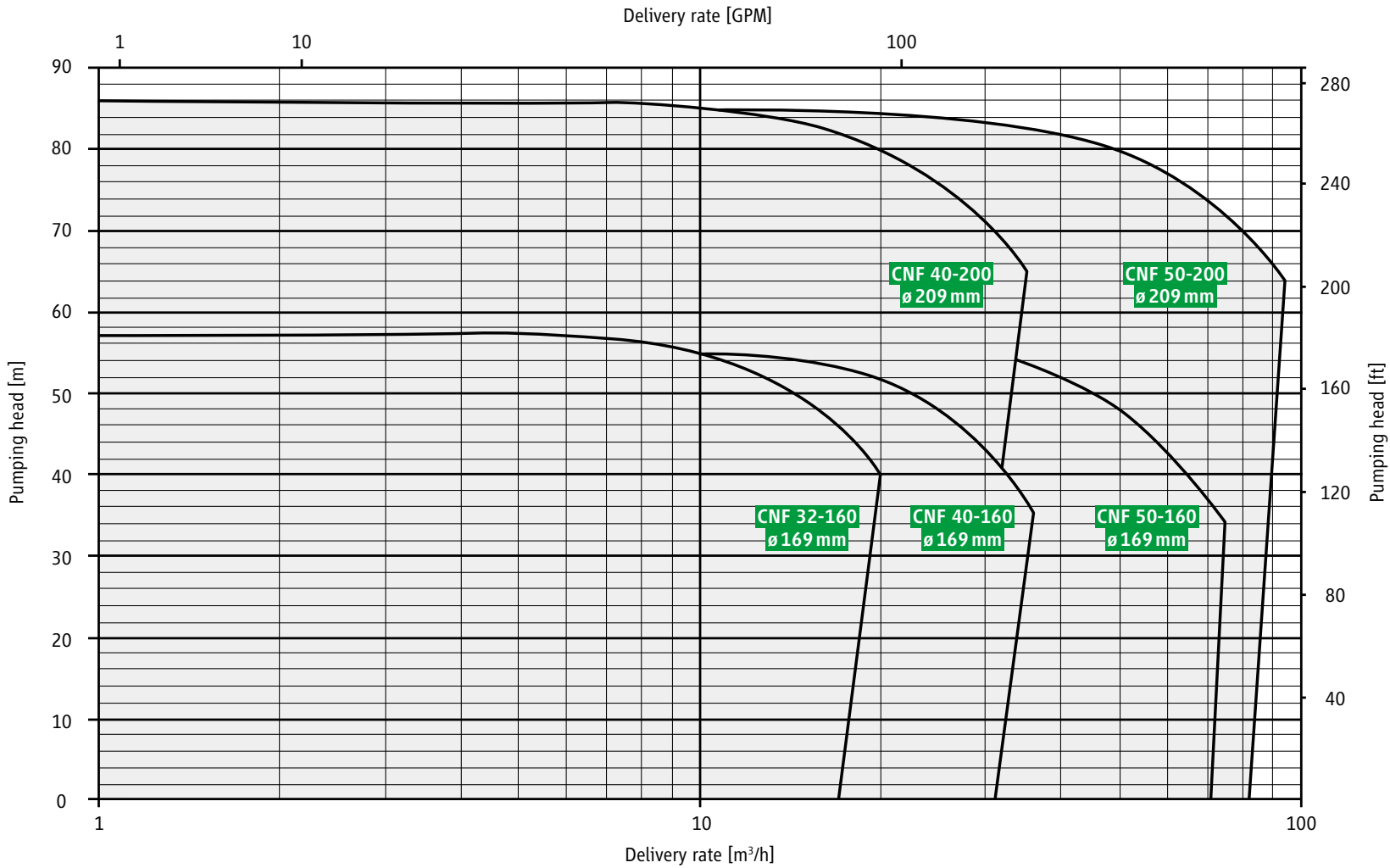

- Table of Contents
- General information
- Function
- Operating principle
- Characteristic maps**
- Versions
- List of parts
- Collective measurements
- Documentation and tests
- Installation
- Protection and monitoring
- Flow regulation
- Design software
- Contact





## Versions CNF

Type	Motor	Pump data		Motor data 50 Hz / 60 Hz		Weight kg	PN
		Q <sub>min.</sub> m <sup>3</sup> /h	Q <sub>max.</sub> m <sup>3</sup> /h	Output kW [P2]	Rated current at 400 V/480 V		
CNF 32 – 160	AGX 3.0	3.0	20.0	3.0/3.4	7.1	55.0	40
	AGX 4.5	3.0	20.0	4.5/5.6	10.4	63.0	40
CNF 40 – 160	AGX 3.0	4.0	26.0	3.0/3.4	7.1	58.0	40
	AGX 4.5	4.0	26.0	4.5/5.6	10.4	66.0	40
	AGX 6.5	4.0	26.0	6.5/7.4	15.2	69.0	40
	AGX 8.5	4.0	26.0	8.5/9.2	19.0	80.0	40
CNF 40 – 200	AGX 4.5	4.0	26.0	4.5/5.6	10.4	74.0	40
	AGX 6.5	4.0	26.0	6.5/7.4	15.2	77.0	40
	AGX 8.5	4.0	26.0	8.5/9.2	19.0	90.0	40
	CKPx 12.0	6.0	26.0	13.5/15.7	31.0	122.0	25
CNF 50 – 160	AGX 4.5	8.0	60.0	4.5/5.6	10.4	77.0	40
	AGX 6.5	8.0	60.0	6.5/7.4	15.2	80.0	40
	AGX 8.5	8.0	60.0	8.5/9.2	19.0	91.0	40
	CKPx 12.0	8.0	60.0	13.5/15.7	31.0	118.0	25
CNF 50 – 200	AGX 6.5	8.0	60.0	6.5/7.4	15.2	82.0	40
	AGX 8.5	8.0	60.0	8.5/9.2	19.0	96.0	40
	CKPx 12.0	8.0	60.0	13.5/15.7	31.0	125.0	25

Table of Contents

General information

Function

Operating principle

Characteristic maps

**Versions**

List of parts

Collective measurements

Documentation and tests

Installation

Protection and monitoring

Flow regulation

Design software

Contact



## Materials / pressure stages / flanges

---

Housing	JS 1025
Impeller	JL 1040
Slide bearing	1.4021 / carbon
Shaft	1.4021
Rotor lining	1.4571
Seals	AFM 34*
Pressure rating	PN 40**
Flanges	according to DIN EN 1092-1, PN 40 type D

\* asbestos-free aramid fibre, \*\* test pressure 60 bar

## Noise expectancy values

---

Motors	AGX 3.0	AGX 4.5	AGX 6.5	AGX 8.5	CKPx 12.0
Output power [P2 at 50 Hz]	3.0 kW	4.5 kW	6.5 kW	8.5 kW	13.5 kW
max. expected sound pressure level dB(A) at 50 Hz	52	54	56	57	59
Output power [P2 at 60 Hz]	3.4 kW	5.6 kW	7.5 kW	9.7 kW	15.7 kW
max. expected sound pressure level dB(A) at 60 Hz	52	55	56	57	59

[Table of Contents](#)

[General information](#)

[Function](#)

[Operating principle](#)

[Characteristic maps](#)

**Versions**

[List of parts](#)

[Collective measurements](#)

[Documentation and tests](#)

[Installation](#)

[Protection and monitoring](#)

[Flow regulation](#)

[Design software](#)

[Contact](#)



List of parts **CNF**

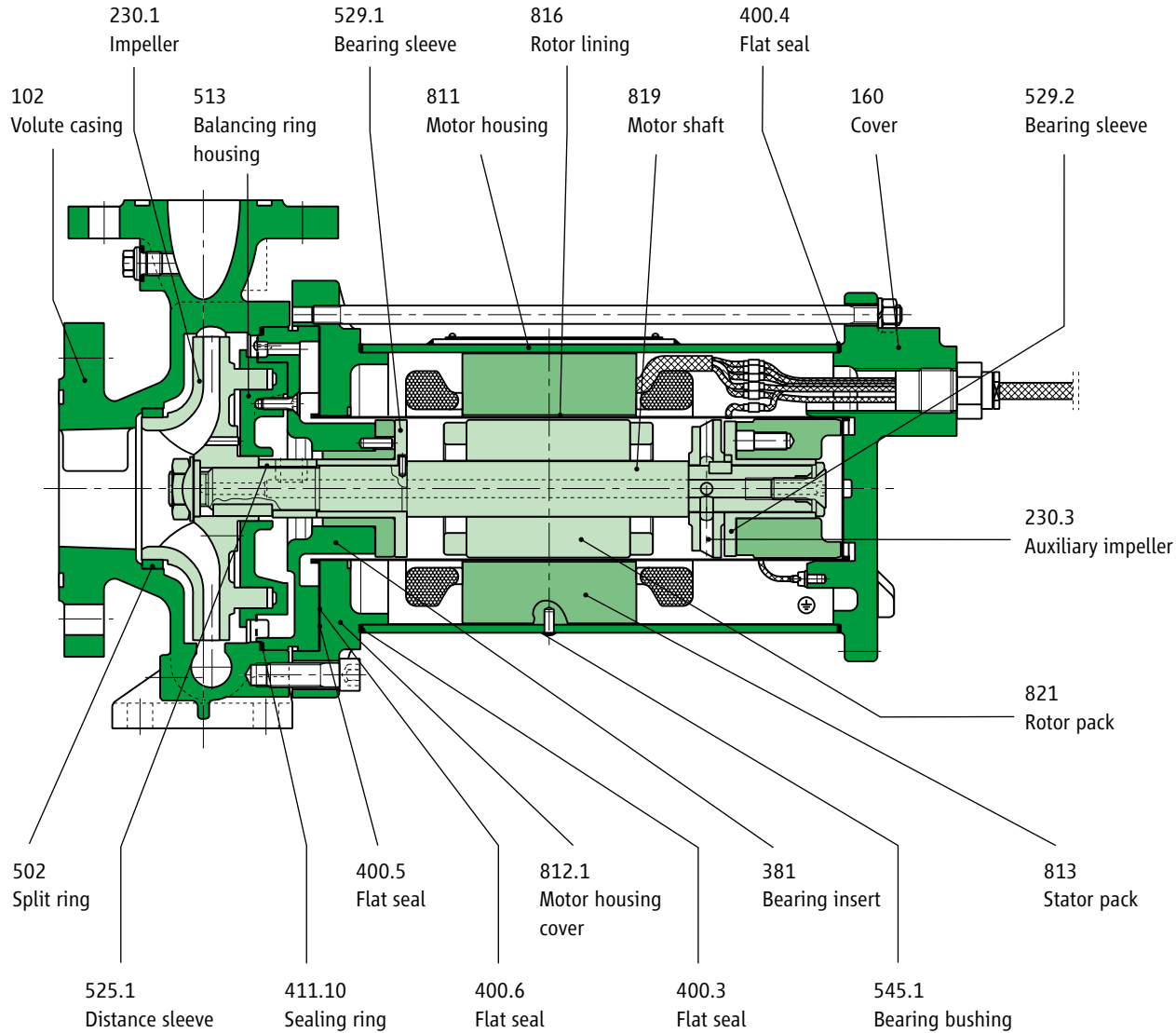

- Table of Contents
- General information
- Function
- Operating principle
- Characteristic maps
- Versions
- List of parts**
- Collective measurements
- Documentation and tests
- Installation
- Protection and monitoring
- Flow regulation
- Design software
- Contact



Dimension drawings

Dimension drawing for motors of size:  
AGX 3.0 / AGX 4.5 / AGX 6.5

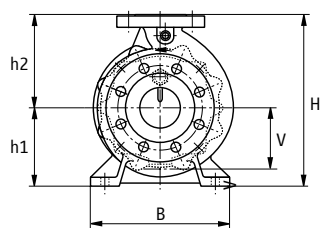
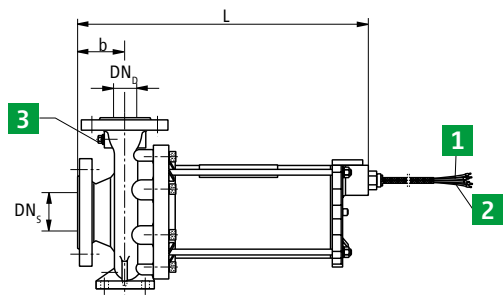

- 1 Cable U1, V1, W1 + protective conductor  
AGX 3.0: 4 x 1.5 mm<sup>2</sup>  
AGX 4.5: 4 x 2.5 mm<sup>2</sup>  
AGX 6.5: 4 x 4 mm<sup>2</sup>
- 2 Cable for PTC thermistor 2 x 1.0 mm<sup>2</sup>,  
Cable 5 + 6, cable length 2.5 m
- 3 Pressure gauge connection G 1/4

Dimension drawing for motors of size:  
AGX 8.5 / CKPx 12.0

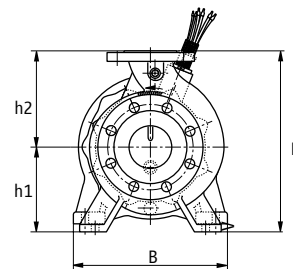
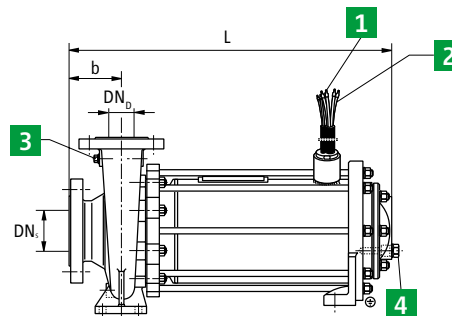

- 1 Cable U1, V1, W1 + protective conductor ⊕  
4 x 6 mm<sup>2</sup>, cable length 2.5 m
- 2 Cable for PTC thermistor 2 x 1.0 mm<sup>2</sup>,  
Cable 5 + 6, cable length 2.5 m
- 3 Pressure gauge connection G 1/4
- 4 Connection for temperature sensor  
closed with screw plug DIN 912, G 1/2

Table of Contents

General information

Function

Operating principle

Characteristic maps

Versions

List of parts

Collective measurements

Documentation and tests

Installation

Protection and monitoring

Flow regulation

Design software

Contact



## Versions CNF

Dimensions	CNF 32 – 160	CNF 40 – 160	CNF 40 – 160	CNF 40 – 200	CNF 40 – 200	CNF 50 – 160	CNF 50 – 160	CNF 50 – 200	CNF 50 – 200
	AGX 3.0/4.5	AGX 3.0/4.5/6.5	AGX 8.5	AGX 4.5/6.5	AGX/CKPx 8.5/12.0	AGX 4.5/6.5	AGX/CKPx 8.5/12.0	AGX 6.5	AGX/CKPx 8.5/12.0
Length / L	506	506	575	526	595/620	526	595/620	526	595/620
Width / W	240	240	240	265	265/290	265	265/290	265	265/290
Height / H	292	292	292	340	340	340	340	360	360
h1	132	132	132	160	160	160	160w	160	160
h2	160	160	160	180	180	180	180	200	200
b	80	80	80	100	100	100	100	100	100
v	100	100	100	115	115	108	108	118	118
DN <sub>s</sub>	50	65	65	65	65	80	80	80	80
DN <sub>b</sub>	32	40	40	40	40	50	50	50	50

Table of Contents

General information

Function

Operating principle

Characteristic maps

Versions

List of parts

**Collective measurements**

Documentation and tests

Installation

Protection and monitoring

Flow regulation

Design software

Contact



## Documentation and tests

---

### Documentation according to HERMETIC Standard consisting of:

Operating manual for the HERMETIC pump

---

Technical specifications

---

Characteristic curve of the pump

---

Sectional drawing

---

Bills of materials

---

Dimensional drawing

---

Cable connection diagram

---

Plain bearing play

---

EU Declaration of Conformity

### Warranty

---

30 months from delivery

### Standard tests

---

Hydrostatic pressure test with 1.5x nominal pressure

---

Balancing of shaft and impeller according to DIN ISO 1940, 6.3

---

Leak test of the complete pump

---

Functional test (optionally with protocol)

### Additional test

---

Factory certificate according to EN 10204 / 3.1 for pressurised parts in contact with medium (chemical analysis)

---

Factory certificate according to EN 10204 / 3.1 for counter flanges

---

Factory certificate according to EN 10204 / 2.2 for impeller and pump shaft

---

EUR.1 movement certificate (after examination)

---

RMRS / DNV / Hapag Lloyd

Table of Contents

General information

Function

Operating principle

Characteristic maps

Versions

List of parts

Collective measurements

**Documentation and tests**

Installation

Protection and monitoring

Flow regulation

Design software

Contact



### Automatic venting

1. Use a non-return valve between the discharge nozzle and gate valve to ensure that the medium does not flow back after switching off the pump.
2. To allow venting, provide a bypass pipe:
  - Ahead of the non-return valve.
  - Please note: do not provide non-return valves in the bypass pipe.
3. For parallel operation:
  - Separate supplies for the pumps
  - Separate bypass pipes

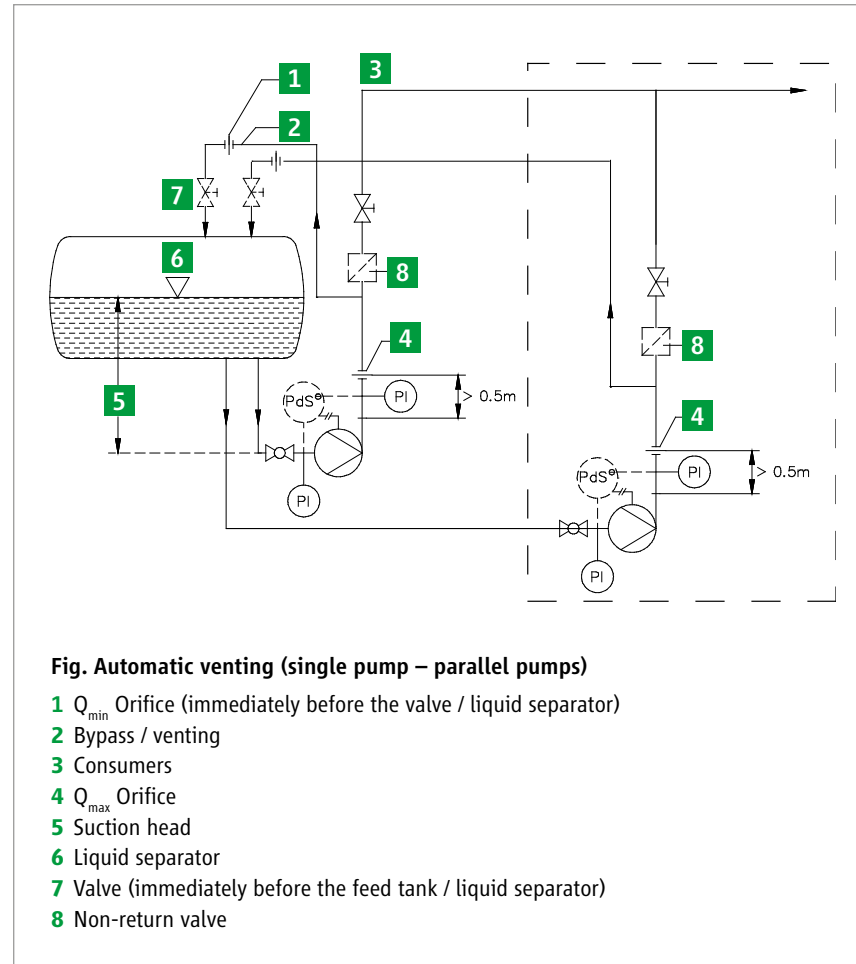

- Table of Contents
- General information
- Function
- Operating principle
- Characteristic maps
- Versions
- List of parts
- Collective measurements
- Documentation and tests
- Installation**
- Protection and monitoring
- Flow regulation
- Design software
- Contact



## Orifice and inducer

### Orifice

We recommend protecting the HERMETIC pumps by using two orifices against any outside influence (for example by operating personnel). Orifice 1 ( $Q_{\min}$ ) ensures the minimum throughput required to dissipate the motor heat loss. Orifice 2 ( $Q_{\max}$ ) maintains the minimum differential pressure in the rotor space that is needed to stabilise the hydraulic axial thrust balancing and to prevent the evaporation of the partial flow. A flow regulator can be used instead of the  $Q_{\max}$  orifice.

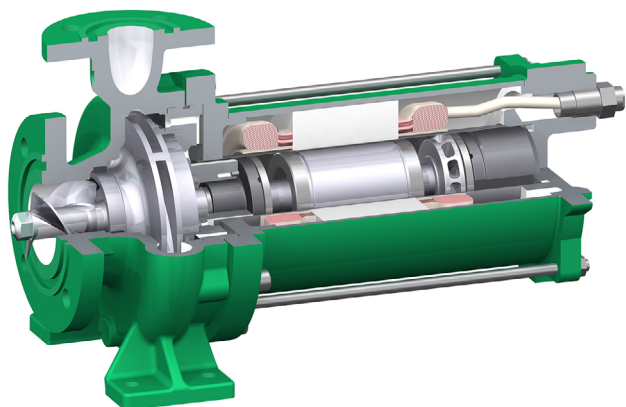

### Inducer

Inducers are axial impellers that are arranged on the same shaft immediately in front of the first impeller of a centrifugal pump to generate an additional static pressure in front of the blade cascade of the impeller. Inducers are primarily used where the energy level provided by the system is insufficient ( $NPSHA > NPSHR$ ). The HERMETIC inducer reduces the NPSHR value of the pump by approx. 0.5 m over the entire characteristic curve. In many cases, inducers are also used prophylactically if the expected resistance of the inlet or suction line cannot be accurately determined or if fluctuations in NPSHA are expected due to changes in the geodetic height of the inlet liquid level or its pressure superimposition. Inducers are also particularly suitable for conveying boiling liquids (that are afflicted with gas bubbles). In both cases, the inducer can be used to prevent cavitation or reduced output provided it is correctly calculated and matches the flow rate of the impeller it feeds.

Table of Contents

General information

Function

Operating principle

Characteristic maps

Versions

List of parts

Collective measurements

Documentation and tests

Installation

**Protection and monitoring**

Flow regulation

Design software

Contact





## Flow regulator

### General information

The flow regulator was specially developed for refrigerant systems. This type of valve allows the safe operation of pumps in a range normally not possible for pumps with  $Q_{\max}$  orifice. The adjacent graph shows the added operating range obtained by using a flow regulator instead of a  $Q_{\max}$  orifice. Often, a smaller, less expensive pump can be used.

### Operation

The flow regulator must be filled with liquid during operation. The operation of the valve depends on the material data of the pumped medium. When ordering the valve, it is therefore important that complete information on the characteristics of the pumped medium in the operating range to be regulated is available. The density of the pumped medium is the most important characteristic for the correct design of a valve.

### Maintenance

The flow regulator requires no regular maintenance or readjustment. The valve inserts can be reordered if necessary.

### Area of application

The flow regulator is mounted on the discharge branch of the pump. The flow regulator limits the maximum flow rate of the pump. However, in contrast to the  $Q_{\max}$  orifice, the flow rate  $< Q_{\max}$  is almost equal to the full delivery pressure of the pump behind the valve. The flow regulator regulates the delivery rate to ensure that the maximum pump capacity is not exceeded. This protects the pump from overload and keeps the delivery rate within the optimum NPSH range of the pump.

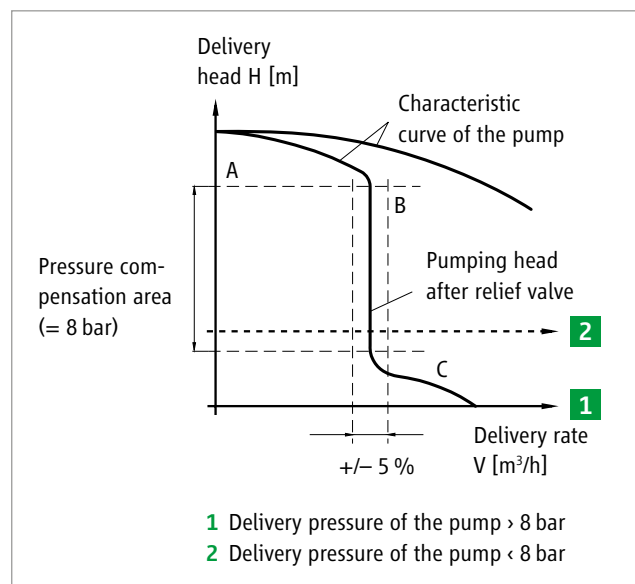

Table of Contents

General information

Function

Operating principle

Characteristic maps

Versions

List of parts

Collective measurements

Documentation and tests

Installation

Protection and monitoring

**Flow regulation**

Design software

Contact



## Flow regulator

### Working principle

The flow restriction is achieved by specially shaped openings in a spring-loaded, movable piston. The pressure difference in front of and behind the piston moves it. This ensures that only the appropriate amount flows through the openings. It follows that with increasing pressure difference, the spring is compressed. This means that the specially shaped openings are only partially released. When the pressure difference in front of and behind the valve decreases, the spring pushes the piston back in line with the changing pressure difference releasing a larger part of the opening. If the pressure difference exceeds the specified maximum value (pressure compensation range, generally 8 bar), the spring is compressed up to the stop, and the valve then works like a fixed orifice. The same applies when the required minimum pressure is not reached.

#### Functional schematic of the valve

##### Position A

In position A, the insert works as an orifice. As a result, little pressure is relieved at the valve.

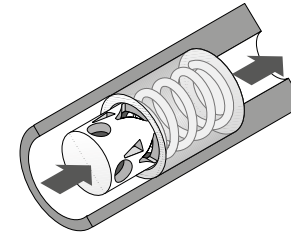

##### Position B

In the pressure compensation range, the insert limits the maximum volumetric flow rate as a function of the differential pressure with an accuracy of  $\pm 5\%$ .

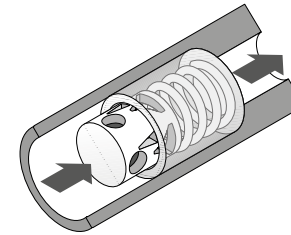

##### Position C

Behind the pressure compensation area, the insert is completely compressed and acts as an orifice.

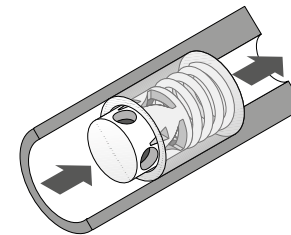

Table of Contents

General information

Function

Operating principle

Characteristic maps

Versions

List of parts

Collective measurements

Documentation and tests

Installation

Protection and monitoring

**Flow regulation**

Design software

Contact



## Flow regulator and list of parts

The valve is available for the following flow rates

Model	Pressure rating	NW	max. flow rate for H <sub>2</sub> O
32-40-40-10	40 bar	32	10,00 m <sup>3</sup> /h
40-40-80-19	40 bar	40	19,30 m <sup>3</sup> /h
40-40-80-25	40 bar	40	25,00 m <sup>3</sup> /h
40-40-80-34	40 bar	40	34,10 m <sup>3</sup> /h
50-40-80-25	40 bar	50	25,00 m <sup>3</sup> /h
50-40-80-34	40 bar	50	34,10 m <sup>3</sup> /h

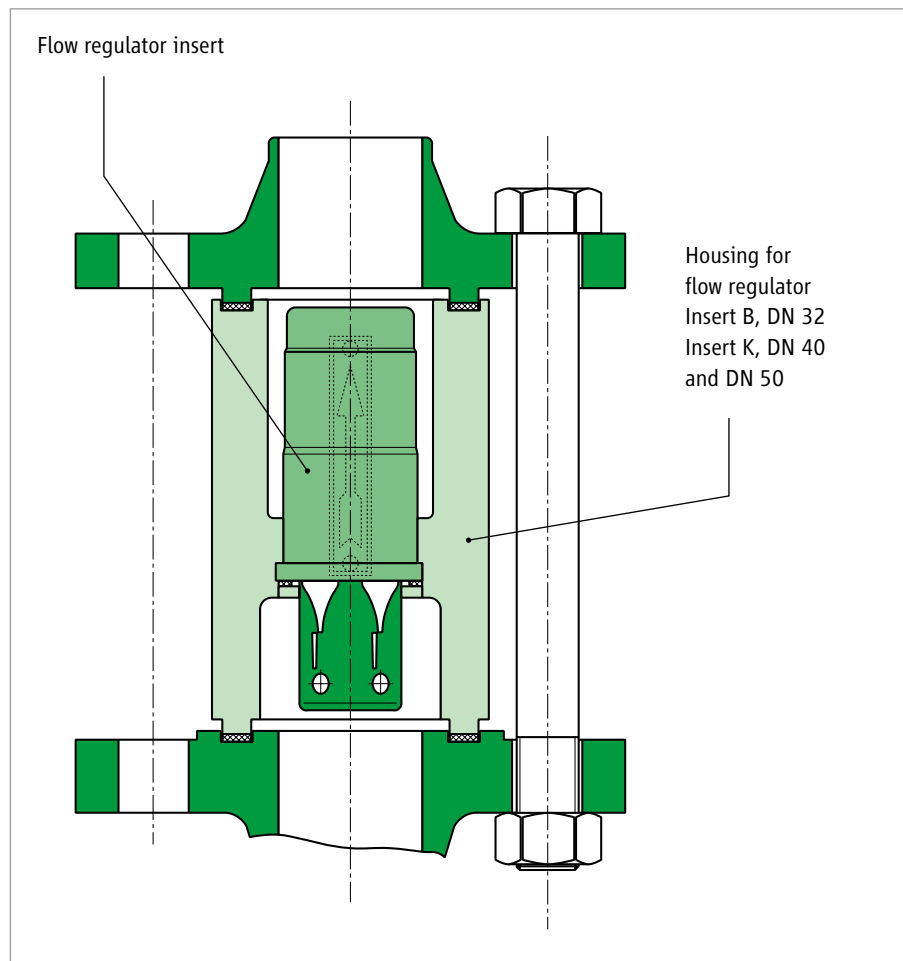

Table of Contents

General information

Function

Operating principle

Characteristic maps

Versions

List of parts

Collective measurements

Documentation and tests

Installation

Protection and monitoring

**Flow regulation**

Design software

Contact



## Design software / services

### Online design

The user-oriented design software simplifies the selection of the right refrigerant pump. It is also possible to calculate the energy-saving options with the software. The software-based design for frequency-controlled operation is easily possible. Minimum and maximum speeds and the appropriate operating range are displayed.

### Quick registration

Do you want to know more about the many benefits of our new design software?

Simply register as a new user on our homepage  
[www.hermetic-pumpen.com](http://www.hermetic-pumpen.com)

After registration and receiving the access data, you can test the design software free of charge. Registered users simply log in using their access data – a new registration is not required.

### Other online services

We provide free 3D CAD models for your planning and your design office.

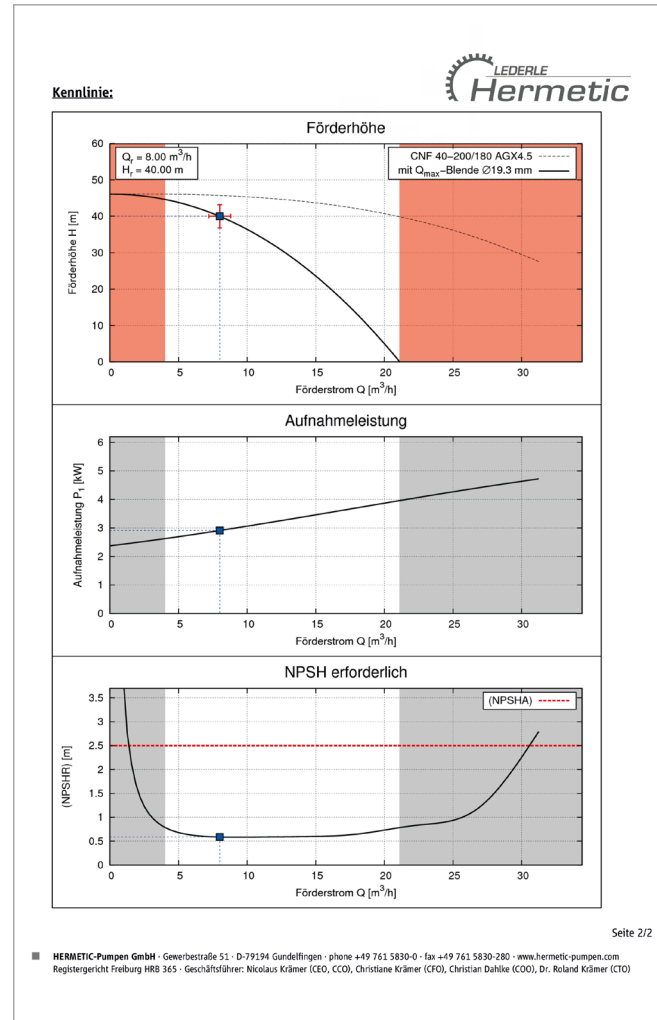

Example view after pump selection

Table of Contents

General information

Function

Operating principle

Characteristic maps

Versions

List of parts

Collective measurements

Documentation and tests

Installation

Protection and monitoring

Flow regulation

**Design software**

Contact



## Benefits of the design software

---

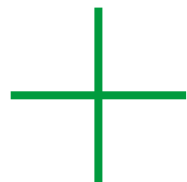

Direct entry of the required refrigeration capacity

---

Dynamic selection according to power consumption, NPSH

---

The database contains all common refrigerants

---

Integration of different pump protection systems, such as  $Q_{max}$  orifice or flow regulator

---

Design for variable-speed drives

---

Table of Contents

General information

Function

Operating principle

Characteristic maps

Versions

List of parts

Collective measurements

Documentation and tests

Installation

Protection and monitoring

Flow regulation

**Design software**

Contact



PRODUCT INFORMATION

# Contact

[sales-support@hermetic-pumpen.com](mailto:sales-support@hermetic-pumpen.com)

[www.hermetic-pumpen.com](http://www.hermetic-pumpen.com)

YouTube | LinkedIn | Expert tool

Table of Contents

General information

Function

Operating principle

Characteristic maps

Versions

List of parts

Collective measurements

Documentation and tests

Installation

Protection and monitoring

Flow regulation

Design software

**Contact**

